

**Methoxy and Trifluoromethyl Substituted  
Benzocyclobutenone and Benzocyclobutenedione Chromium  
Complexes**

DISSERTATION

Vom Fachbereich Chemie der  
Universität Hannover  
zur Erlangung des Grades  
Doktor der Naturwissenschaften  
- Dr. rer. nat. -

genehmigte Dissertation von

**Krishna Gopal Dongol, M.Sc.**

geboren am 19.01.1968 in Kathmandu / Nepal

**März 2001**

The present work has been performed between April 1998 to November 2000 in the Institut für Organische Chemie, University of Hannover, Hannover, Germany, under the supervision of Prof. Dr. H. Butenschön.

Hannover, in March 2001

Referee : Prof. Dr. H. Butenschön

Co-Referee : Prof. Dr. H. Duddeck

Promotion Day: 18<sup>th</sup> April 2001

## Abstract

### **Methoxy- und Trifluoromethylsubstituierte Benzocyclobutenone und Benzocyclobutendion Chromkomplexe**

Die nucleophile Addition von Grignardreagenzien an den 6-Methoxybenzocyclobutenon-Komplex **43** und den 3-Methoxybenzocyclobutendion-Komplex **42** findet ausschließlich von der dem Chromfragment abgewandten Seite her statt und führt bei tiefen Temperaturen zu exo-substituierten Hydroxybenzocyclobuten-Komplexen. Bei der Addition von Alkylolithium-Verbindungen an den 6-Methoxybenzocyclobutenon-Komplex **43** erhält man nur das proximale Ringöffnungsprodukt. Durch die Behandlung des 1-endo-Hydroxy-6-methoxybenzocyclobutenol-Komplexes mit Alkylolithiumreagenzien bildet sich intermediär ein *ortho*-Chinodimethan-Intermediat, das mit einer Vielzahl von Dienophilen [4+2] Cycloadditionen eingeht.

Bei der Reaktion von ( $\eta^6$ -1-*endo*-Hydroxy-6-methoxybenzocyclobutenol)-tricarbonsäurechrom (**58**) mit Butyllithium bei  $-78\text{ }^\circ\text{C}$  beobachtet man eine anionisch beschleunigte Vinylcyclobuten-Cyclohexadien Umlagerung, die zu einem Tetralonkomplex führt. Solch eine Umlagerung kann ebenfalls bei der Umsetzung des 3-Methoxybenzocyclobutenon-Komplexes **42** mit 2-Lithio-3,4-dihydro-2*H*-pyran bei  $-78\text{ }^\circ\text{C}$  erhalten werden.

Die Einführung einer Methoxygruppe am aromatischen Ring bedingt eine Symmetrieerniedrigung, welche selektive Additions- und Deacetalisierungsreaktionen ermöglicht. Auf diese Weise konnte die unterschiedliche Reaktivität der Ketofunktionen gezeigt werden.

Die monovinylsubstituierten Komplexe **126** und **127** wurden mit verschiedenen Nucleophilen bei  $-78\text{ }^\circ\text{C}$  umgesetzt. Beobachtet wurde eine dianionische Oxy-Cope-Umlagerung gefolgt von einer selektiven intramolekularen Aldoladdition, bei denen jeweils nur eines der zwei postulierten Produkte in hoher Ausbeute entstand. Bestätigt wurde dieses Erkenntnis bei der direkten Zweifachaddition von Alkylolithiumverbindungen und anschließender Oxy-Cope-Umlagerung. Auch in diesem Fall erhielt man nach der intramolekularen Aldoladdition mit übereinstimmender Selektivität nur ein Produkt.

Diese Resultate zeigen eindrucksvoll den dirigierenden Einfluß des Methoxysubstituenten, der durch Chelatisierung die selektive Protonierung des Di(enolat)intermediats bedingt.

In Analogie zur bekannten Syntheseroute der methoxysubstituierten Benzocyclobutenonkomplexe wurden trifluoromethylsubstituierte Liganden und der 6-(Trifluormethyl)benzocyclobutenon-Komplex **168** dargestellt und durch Röntgenstrukturanalyse eindeutig charakterisiert.

Methoxy- und Trifluoromethyl- substituierte Benzocyclobutenon und -dion Komplexe • Diastereoselektive Addition • Cycloaddition • Vinylcyclobuten-Cyclohexadien- Umlagerung • Dianionische oxy-Cope-Umlagerung • Selektive intramolekulare Aldol-Addition • Selektive Dienolat-Hydrolyse • Chromkomplexe.

## Abstract:

### **Methoxy and Trifluoromethyl Substituted Benzocyclobutenone and Benzocyclobutendione Chromium Complexes**

The nucleophilic additions of Grignard reagents to 6-methoxybenzocyclobutenone complex **43** and 3-methoxybenzocyclobutenedione complex **42** occur from the face opposite to the chromium moiety and lead to *exo*-substituted hydroxybenzocyclobutene complexes at low temperature. Addition of alkyllithium to 6-methoxybenzocyclobutenone complex **43** leads only to the proximal ring opening product. On treatment of the 1-*endo*-hydroxy-6-methoxybenzocyclobutenol complex with alkyllithiums, an *ortho*-quinodimethane intermediate is formed, which undergoes [4+2] cycloadditions in the presence of a variety of dienophiles.

After treatment of 1-*endo*-hydroxy-1-*exo*-vinyl-6-methoxybenzocyclobutenol complex (**58**) with butyllithium at  $-78\text{ }^{\circ}\text{C}$ , an oxy-anion driven vinylcyclobutene-cyclohexadiene rearrangement was observed resulting in a  $\alpha$ -tetralone complex. Such rearrangement was also observed, when the 3-methoxybenzocyclobutendione complex **42** was treated with 2-lithio-3,4-dihydro-2*H*-pyran at  $-78^{\circ}\text{C}$ .

Taking benefit of the reduction of symmetry by introduction of the methoxy group at the aromatic ring was subjected to selective addition and deacetalization reactions, which show the difference of reactivity of the two ketone functionalities.

The mono vinyl adducts complexes **126** and **127** were treated with other nucleophiles at  $-78\text{ }^{\circ}\text{C}$ , and a dianionic oxy-Cope rearrangement followed by selective intramolecular aldol addition was observed giving selectively one of the two possible products in high yield. To get a clear information about the selectivity, the 3-methoxybenzocyclobutendione complex **42** was treated with same nucleophiles at low temperature, and a similar type of selectivity is observed in a dianionic oxy-Cope rearrangement followed by an intramolecular aldol addition. This result indicates that the methoxy group and an enolate near to it, chelated by a lithium ion, favour the selective protonation (hydrolysis) at the enolate, which is free from chelation. This indicates a significant role of the methoxy substituent for the selective aldol adduct.

By using the same approach of synthesis used for the preparation of methoxy substituted complexes, trifluoromethyl substituted ligands have been prepared and the complex of 6-trifluoromethylbenzocyclobutenone **168** has also been prepared and characterized by crystallographically.

Methoxy- and trifluoromethyl substituted benzocyclobutenone and -dione complexes • Diastereoselective addition • Cycloaddition • Vinylcyclobutene-cyclohexadiene rearrangement • Dianionic oxy-Cope rearrangement • Selective intramolecular aldol addition • Selective dienolate hydrolysis • Chromium complexes.

For my Laxmi  
and Parents



## Acknowledgments

I would like to express my deep and sincere appreciation to my supervisor Prof. Dr. Holger Butenschön for his friendly guidance, constant care and encouragement throughout the course of present work. I am also thankful to him for giving me an interesting working field for the thesis and providing me with complete freedom during the work, specially his patience, in the start of work when the things were not going well.

I would like to thank "Gottlieb Daimler- und Karl Benz-Stiftung" for providing continuous funding during this study.

Many thanks to Frau Kandil for her friendly help making it much easier for me to stay in Germany.

My special thanks are extended to all of our group members Dr. Li Yong, Dipl.-Chem. Markus Schwarz, Dipl.-Chem. Ingo Weidner and Dipl.-Chem. Matthias Schnebel for making it enjoyable and easy to work in the lab.

My special thanks to Dipl.-Chem. Matthias Schnebel for the proof reading of my thesis and giving me invaluable suggestions during my research work.

I would also like to thank to my senior colleagues Dr. Dirk Leinweber, Dr. Markus Strotmann, Dr. Uwe Behrendt, Dr. Christian Clausen, Dr. Holger Ziehe, Dipl.-Chem. Robert-Michael Pfeiffer, Dr. Nissan Ashkenazi, and Dr. Alf Kakoschke for sharing with me their experiences during the start of my work.

My thanks are due to Dr. Muhammad Shahid Malik for final proof reading and giving me friendly suggestions, whenever I needed.

I am thankful for the advises, encouragment and support to all my colleagues in the institute.

I wish to record special thanks to "spectroscopy family", particularly, Dr. Hofer, Ms. Monika Rettstedt, Ms. Dagmer Körtja, Mr. R. Nöthel and Ms. Christine Bartetzko for recording my spectra in time and for their friendly behaviour.

I thank to Mr. D. Herre for helping to solve technical problems of instruments without hesitation during my work.

I wish to acknowledge Dr. Wartchow, Institute für Anorganische Chemie, for performing many crystal structures in time.

Thanks to my friends staying in Hannover Mr. Chandra Prasad Joshi and Mr. Millan Poudel for helping whenever I needed help during my stay in Germany.

I hardly find any words to express my gratitude to my parents and brother Radha Krishna Dongol, for their moral support and encouragement.

Finally, I wish to thank my Laxmi and Keynesh for their enduring patience over the innumerable evenings which went to do Ph.D.

**Krishna Gopal Dongol**



## Contents

<b>A</b>	<b>Introduction</b>	<b>1</b>
<b>B</b>	<b>Results and Discussion</b>	<b>15</b>
2.1	Synthesis of Substituted Benzocyclobutenone and Benzocyclobutenedione	15
2.2	Synthesis of Tricarbonyl( $\eta^6$ -6-methoxybenzocyclobutene)-chromium (0) ( <b>43</b> )	17
2.3.	Synthesis of Tricarbonyl ( $\eta^6$ -3-methoxybenzocyclobutenedione) chromium (0)	21
<b>3.</b>	<b>Reduction of Tricarbonyl(<math>\eta^6</math>-6-methoxybenzocyclobutenone)-chromium (0)(<b>43</b>)</b>	<b>25</b>
3.1	Reduction of <b>43</b> with Lithium Aluminium Hydride	25
3.2	Approaches to Prepare the Enantiomerically Enrich 1-Hydroxycyclobutene Complex	26
<b>4</b>	<b>Addition of Carbon Nucleophiles to Tricarbonyl(<math>\eta^6</math>-6-methoxybenzocyclobutenone)chromium (0)(<b>43</b>)</b>	<b>28</b>
4.1	Grignard Reagents Addition	28
4.2	Treatment of 1- <i>endo</i> -Hydroxy-1- <i>exo</i> -vinyl-6-methoxybenzocyclobutene Complex ( <b>67</b> ) with Butyllithium	29
4.3	Addition of Alkenyl and Alkynyllithium to the Complex <b>43</b>	30
4.4	Addition of Oxygen and Nitrogen Nucleophiles	34
<b>5</b>	<b>Anionic Ring Opening of Tricarbonyl(<math>\eta^6</math>-6-methoxybenzocyclobutenol)chromium (0) (<b>58</b>) followed by [4+2] Cycloaddition</b>	<b>36</b>
5.1	Anionic Ring Opening Followed by Cycloaddition in the Unsubstituted Complex	36
5.2	Anionic Ring Opening Followed by [4+2] Cycloaddition in the 1- <i>endo</i> -Hydroxy-6-methoxybenzocyclobutene Complex <b>58</b>	37
5.2.1	Cycloaddition with Methyl Acrylate	37
5.2.2	Cycloaddition with vinyl sulfones	39
5.2.3	Cycloaddition with Dimethyl Butynedionate	41

5.2.4	[4+2] Cycloaddition with Tricarbonyl( $\eta^6$ - <i>endo</i> -1-hydroxy- <i>exo</i> -1-methyl-6-methoxybenzocyclobutene)chromium (0) ( <b>62</b> )	42
5.3	Proximal ring opening	43
5.4	Attempts to an Intramolecular [4+2] cycloaddition from <b>64</b>	44
5.5.	Hetero Diels Alder Cycloaddition	46
<b>6.</b>	<b>Nucleophilic Addition at Benzocyclobutenedione Complex <b>42</b> and Dianionic Oxy-Cope Rearrangement</b>	<b>47</b>
6.1	Background	47
6.2	Dianionic Oxy-Cope Rearrangement followed by Intramolecular Aldol Addition	50
6.2.1	Nucleophilic Addition with Lithium Aluminum Hydride	53
6.2.2	Selective Hydrolysis of Bisacetal Complex <b>57</b>	54
6.2.3	Treatment of the 3-Methoxybenzocyclobutenedione Complex <b>42</b> with One Equivalent of Vinylolithium	57
6.3	Nucleophile Addition to the complex <b>126</b>	59
6.3.1	Addition of Vinylolithium to <b>126</b>	59
6.3.2	Nucleophilic Addition of 1-Cyclopentenyllithium to the Complex <b>126</b>	62
6.3.3	Nucleophilic Addition of Substituted Vinylolithium(2-Propenyllithium) to Complex <b>126</b>	70
6.4	Double Nucleophilic Addition to the 3-Methoxybenzocyclobutenedione Complex <b>42</b>	72
6.4.1	Addition of Vinylolithium to the Complex <b>42</b>	72
6.4.1	Double Addition of 2-Propenyllithium to Complex <b>42</b>	73
6.4.2	Double Addition of 1-Ethoxy-1-Lithioethene to Complex <b>42</b>	77
6.4.2	Addition of Lithiated methoxyallene to Complex <b>42</b>	78
6.4.3	Double Addition of 1-Cyclopentenyllithium to Complex <b>42</b>	79
<b>7.</b>	<b>Dianionic oxy-Cope with Heterocyclic Compounds</b>	<b>83</b>
7.1	Non Aromatic Heterocyclic Alkenyllithium	84
7.2	Nucleophilic Addition of 2-Lithio-3,4-dihydro-2 <i>H</i> -pyran to the <b>42</b>	87
7.3.	Addition of 2-Lithiofurane to the Complex <b>42</b>	93

<b>8</b>	<b>Approach to the 6-Trifluoromethylbenzocyclobutenone complex 168 and 3-Trifluorobenzocyclobutenedione Complex 169</b>	<b>94</b>
8.1.	Preparation of Uncoordinated 6-Trifluoromethylbenzocyclobutenone (173) And 3-Trifluoromethylbenzocyclobutenedione (175)	94
8.1.1.	Synthesis of 6-Trifluoromethylbenzocyclobutenone (173)	94
8.1.2	Preparation of uncoordinated trifluoromethylbenzocyclobutenedione	96
8.2	Preparation of 6-Trifluoromethylbenzocyclobutenone Complex 168	97
8.3	Attempted to prepare 3-Trifluoromethylbenzocyclobutenedione Complex 169	101
<b>C</b>	<b>Summery and Conclusion</b>	<b>104</b>
<b>D</b>	<b>Experimental Section</b>	<b>118</b>
<b>9</b>	<b>General</b>	<b>118</b>
9.1	Analytical Methods	118
10.1	Crystallization of 3-Methoxybenzocyclobutenedione Complex 42	120
10.2	Crystallization of 6-Methoxybenzocyclobutenone Complex 43	121
<b>11</b>	<b>Tricarbonyl[<math>\eta^6</math>-(1-<i>endo</i>-hydroxy-6-methoxybezocyclobutene)]-chromium(0)</b>	<b>122</b>
<b>12</b>	<b>General Method for Grignard Addition to Complex 43 (GP I)</b>	<b>123</b>
12.1	Tricarbonyl ( $\eta^6$ - 1- <i>endo</i> -hydroxy-1- <i>exo</i> -methyl-6-methoxybenzo-cyclobutene)chromium (0) (62)	123
12.2	Tricarbonyl( $\eta^6$ -1- <i>endo</i> -hydroxy-1- <i>exo</i> -vinyl-6-methoxybenzo-cyclobutene)chromium (0) (63)	124
12.3	Tricarbonyl( $\eta^6$ - 1- <i>endo</i> -hydroxy-1- <i>exo</i> -vinyl-6-methoxybenzo-cyclobutene)chromium (0) (64)	125
<b>13</b>	<b>Tricarbonyl(<math>\eta^6</math>- 2,3,4, trihydro-8-methoxy-1-naphthenone)-chromium (0) (67)</b>	<b>126</b>
<b>14</b>	<b>General Method for Addition of Lithium Alkyl Reagents to Complex 43 (GP II)</b>	<b>128</b>
14.1	Tricarbonyl{ $\eta^6$ -[1-(3-methoxyphenyl)-4-trimethylsilylbut-3-yne-2-one]}chromium (0) (68)	128

14.2	Tricarbonyl[ $\eta^6$ -{1-cyclopent-1-enyl-2-(3-methoxyphenyl)-ethanone}]chromium (0) ( <b>69</b> )	129
14.3	Tricarbonyl[ $\eta^6$ -{1-(3-methoxyphenyl)propan-2-one}]chromium(0) ( <b>70</b> )	131
14.4	Tricarbonyl[ $\eta^6$ -2-(3-methoxyphenyl)-1-phenylethanone]-chromium (0) ( <b>71</b> )	132
14.5	Tricarbonyl[ $\eta^6$ -{1-(4,5-Dihydrofuran-2-yl)-2-(3-methoxyphenyl)ethanone}]chromium (0) ( <b>72</b> )	133
14.6	Tricarbonyl[ $\eta^6$ -{1-difuran-2-yl)-2-(3-methoxy-phenyl)ethanone}]-chromium (0) ( <b>74</b> )	134
14.7	Elimination of water from complex <b>74</b>	135
14.8	Tricarbonyl[ $\eta^6$ -2-(3-methoxyphenyl)-1-diphenylethanone]-chromium (0) ( <b>75</b> )	136
<b>15</b>	<b>Tricarbonyl[<math>\eta^6</math>-N-(2,2- Dimethylpent-4-enyl)-2-(3-methoxyphenyl)acetamide]chromium (0) (<b>84</b>)</b>	<b>137</b>
<b>16</b>	<b>General Procedure for the Anionic Ring Opening and [4+2] Cycloaddition with <b>58</b> (GP III)</b>	<b>138</b>
16.1	Anionic Ring Opening and [4+2] Cycloaddition complex <b>58</b> with Methyl Acrylate	139
16.2	Anionic Ring Opening and [4+2] Cycloaddition Complex <b>58</b> with Dimethyl Fumarate	140
16.3	Anionic Ring Opening and [4+2] Cycloaddition complex <b>58</b> with Phenyl Vinyl Sulfone	141
16.4	Anionic Ring Opening and [4+2] Cycloaddition complex <b>58</b> with dimethylbutynedioate	143
16.5	Tricarbonyl[ $\eta^6$ -1-(3-methoxyphenyl)hept-6en-2-one]chromium(0)	144
16.6	Anionic Ring Opening and [4+2] Cycloaddition complex <b>58</b> with Acetonitril	145
<b>17</b>	<b>Reduction of 6-Methoxybenzocyclobutenedione Complex <b>42</b> with Lithium Aluminium Hydride</b>	<b>146</b>

<b>18</b>	<b>Selective Hydrolysis of Bisacetal Complex 56</b>	<b>148</b>
18.1	Treatment of 42 with one equivalent of Vinylmagnesium Bromide Addition	149
<b>19</b>	<b>General Procedure for the single Nucleophilic Addition to 2-endo-hydroxy-2-exo-Vinyl-6-methoxybenzocyclobutenone Complex 126 and Dianionic Oxy-Cope Rearrangement Followed by Selective Intramolecular Aldol Addition (GP IV)</b>	<b>151</b>
19.1	Nucleophilic Addition to 2-endo-hydroxy-2-exo-vinyl-6-methoxybenzo- cyclobutenone complex <b>126</b>	152
19.2	Addition of 1-Cyclopentenyllithium to the mixture of <b>126</b> and <b>127</b> (3:1)	153
19.3	Addition of 2-Propenyllithium to the Complex <b>126</b>	156
<b>20</b>	<b>General Procedure for double Nucleophilic Addition to 6-Methoxy- benzocyclobutenedione Complex 42 and Dianionic Oxy-Cope Rearrangement Followed by Intramolecular Aldol Addition (GP V)</b>	<b>157</b>
20.1	Addition of 2-Propenyllithium to Complex <b>42</b>	158
20.2	Addition of 1-Ethoxy-1-lithioethene to complex <b>42</b>	159
20.3	Additions of 1-Lithio-1-methoxyallene to complex <b>42</b>	160
20.4	Additions of 1-Cyclopentenyllithium to complex <b>42</b>	161
20.5	Additions 2,3-dihydrofuranyllithium to complex <b>42</b>	163
20.6	Addition of 3,4-dihydro-2H-pyranyllithium to complex <b>42</b>	165
20.7	Addition of Furanyllithium to complex <b>42</b>	167
<b>21</b>	<b>Synthesis of Trifluoromethylbenzocyclobutenone and Trifluoro- methylbenzocyclobutenedione complexes</b>	<b>168</b>
21.1	1,1-Diethoxy-6-(trifluoromethyl)benzocyclobutene ( <b>172</b> )	168
21.2	1,1-Diethoxy-6-(trifluoromethyl)benzocyclobutene Complex <b>176</b>	169
21.3	6-Trifluoromethylbenzocyclobutenone complex <b>168</b>	170
21.4	6-Trifluoromethylbenzocyclobutenone ( <b>173</b> )	172
21.5	2,2-Dibromo-6-trifluoromethylbenzocyclobutenone ( <b>174</b> )	173
21.6	3-Trifluoromethylbenzocyclobutenedione ( <b>175</b> )	174
21.7	1,1-Bis(ethylethedioxy)-3-trifluoromethylbenzocyclobutene ( <b>177</b> )	175

21.8	1,1-Bis(ethylenedioxy)-3-trifluoromethylbenzocyclobutene	
	Complex <b>178</b>	176
<b>E</b>	<b>References</b>	<b>178</b>

## Crystal structures

Fig. 2.:	Structure of <b>43</b> in the crystal	18
Fig. 4:	Structure of <b>42</b> in the crystal	22
Fig. 7:	Structure of <b>125</b> in the crystal	55
Fig. 9:	Structure of <b>135</b> in the crystal	64
Fig.11:	Structure of <b>137</b> in the crystal	69
Fig.12:	Structure of <b>149</b> in the crystal	81
Fig. 13:	Structure of <b>159</b> in the crystal	89
Fig.14	Structure of <b>168</b> in the crystal	98





## Abbreviations:

abs.	Absolute
APT	Attached Proton Test
aq	Aqueous
Br	Broad
BuLi	Butyllithium
COSY	Correlated Spectroscopy
Conc.	Concentrated
d	Doublet
de	Diastereoselectivity
DEPT	Distortionless Enhancement by Polarization Transfer
DCM	Dichloromethane
$\delta$	Chemical shift
Et <sub>2</sub> O	Diethyl ether
ee	Enantioselectivity (%)
eq.	Equivalent
PE	Petroleum ether
h	Hour
HRMS	high resolution mass
Hz	Harz
<i>i</i> -Pr	isopropyl
<i>J</i>	Coupling constant
Sat.	Saturated
mL	Milliliter
m	Multiplet
Me	Methyl
min	Minute
MeLi	Methylithium
IR	Infrared spectroscopy
MS	Mass Spectrometry

TBME	<i>tert</i> -butylmethyl ether
<i>tert</i>	Tertiary
NBS	<i>N</i> -Bromosuccinimide
NMR	Nuclear Magnetic Resonance
M	Molar
Ph	Phenyl
THF	Tetrahydrofurane
TMS	Trimethylsilane
Ts	<i>p</i> -toulene sulphone
q	quartet
s	singlet
m.p.	melting point
s	strong

## A. Introduction

In 1910, Finkelstein<sup>1</sup> synthesized the first benzocyclobutene derivative from  $\alpha,\alpha,\alpha',\alpha'$ -tetrabromo-*o*-xylene by treatment with sodium iodide. However, no attention was paid on its chemistry until 1956, when Cava and Napier<sup>2</sup> revised the chemistry of Finkelstein and synthesized the parent benzocyclobutene compound. He also assumed that *o*-quinodimethane (*o*-QDM) (**2**) would be generated as an intermediate in the conversion into benzocyclobutene. After that, some more theoretical and preparative interest on these compounds has been given by chemists, because benzocyclobutene can be used as a versatile precursor for the preparation of other complex organic molecules.<sup>3</sup> Benzocyclobutene and related compounds have interesting physical properties since these compounds represent a unique compromise between the thermodynamic stability associated with a benzenoid aromatic system and the kinetic reactivity of a strained cyclobutene. Fusion of an angularly strained ring to a benzene moiety influences the structure and reactivity of the aromatic fragment to a considerable extent.<sup>4</sup> In a recent study Kass et al.<sup>5</sup> found that fusion of a cyclobutene ring to benzene has a slight acidifying effect at the  $\alpha$ -position and less in  $\beta$ -position of the benzene ring. Benzocyclobutenes are one kind of charming and effective intermediates for the construction of natural products<sup>6</sup> since these compounds are thermally transformed to an *o*-QDM intermediate **2** that can be trapped in presence of some dienophile forming complex [4+2] cycloadducts.

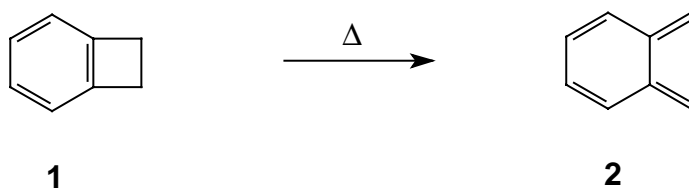

Jensen et al<sup>7</sup> published the first cycloaddition reaction of benzocyclobutene in 1962 employing 1,2-diphenylbenzocyclobutene as a diene precursor and maleic acid anhydride as the dienophile to give the Diels-Alder type cycloadduct. Benzocyclobutene was used as the precursor in the synthesis of complicated ring systems via cycloaddition such as chelidonime,<sup>8</sup> hibaene,<sup>9</sup> atisine,<sup>10</sup> anusenone<sup>11</sup>(**3**) and estrone.<sup>12</sup> Some of the recent applications of this intermediate used for synthesis of steroid are found in a review article by Fukumoto et al,<sup>13</sup>

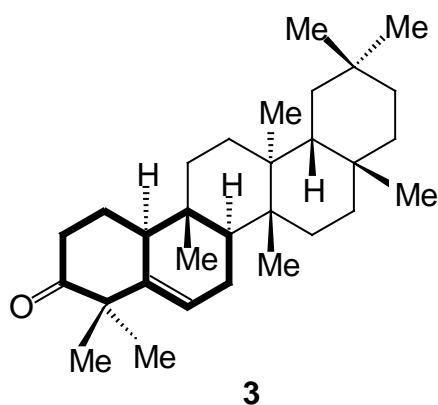

The application of benzocyclobutene is not only limited to the synthesis of natural products but also plays a role in the emerging fullerene chemistry, synthesis of polymeric materials or in material science. Some of the recent applications of *o*-QDM have been reviewed in the article by Martín et al.<sup>14</sup>

*o*-QDM (**2**) can be produced in different ways, thermolysis, 1,4-elimination, thermal extrusion of sulfur dioxide, Diels-Alder cycloreversion, photochemical expulsion of carbon monoxide, photoenolisation or photorearrangement.<sup>15</sup> On heating, benzocyclobutene undergoes a conrotatory electrocyclic ring opening, forming *o*-QDM. Benzocyclobutenes having a substituent at the 4-membered ring in **4** open outward to produce the sterically less hindered (*E*)-*o*-quinodimethanes **5** in preference to the (*Z*) form as **6**,<sup>16</sup> and they open at lower temperature than does unsubstituted benzocyclobutene.<sup>17</sup> Kinetic and stereochemical studies show that a reversible conrotatory opening of four membered ring intermediate **5** or **6** are

formed. This ring opening is followed by supra-supra-facial addition of the non-isolable *o*-QDM to the dienophile forming compound **7** via [4+2] cycloaddition.<sup>18</sup>

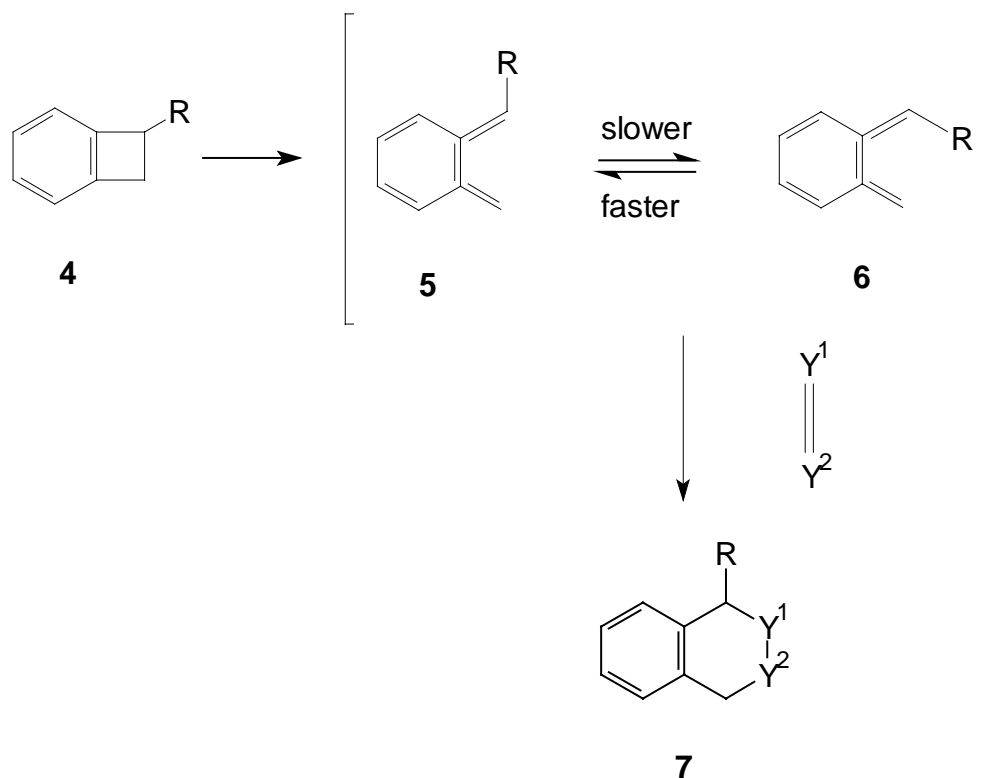

Many natural compounds are chiral and optically pure, and the biological activity of one enantiomer is often completely different from that of its mirror image. For example, this is the case for asperagene, whose *S*-form tastes bitter and whose *R*-form tastes sweet. Hence, among many methods for obtaining planar chiral, optically active compounds, a nonenzymatic process for asymmetric synthesis is using optically pure arene-chromium carbonyl complexes as inducer of chirality.<sup>19</sup> Most of the asymmetric synthesis is performed with chiral arene chromium tricarbonyl arene complexes in the sense that after creation of the desired asymmetric carbon atoms, the chirality is destroyed by decomplexation of the aromatic ring. Only one chiral complex has been used as a recoverable inducer of chirality.

Therefore it is highly interesting to block one enantioface of a prochiral *ortho*-quinodimethane (*o*-QDM) intermediate **5** by coordination to a transition metal, which could result in an asymmetric induction in a cycloaddition reaction.<sup>20</sup> Fischer et al.<sup>21</sup> first synthesized ( $\eta^6$ -benzene)tricarbonylchromium(0) in 1957. Although ( $\eta^6$ -arene)tricarbonylchromium complexes are readily prepared by several convenient methods, a recent study<sup>22</sup> shows that the most suitable solvent for the complexation of organic compounds with hexacarbonylchromium in high yield is an approximately 10/1 mixture of dibutyl ether and THF. In 1976, Semmelhack<sup>23</sup> first summarised the changes in ligand reactivity induced by chromium carbonyl. Since then new methods have been introduced for selective reactions in arene chromium complexes.<sup>24-28</sup> Compared with the uncomplexed ligand the chemistry of the complex is changed as shown in fig 1.

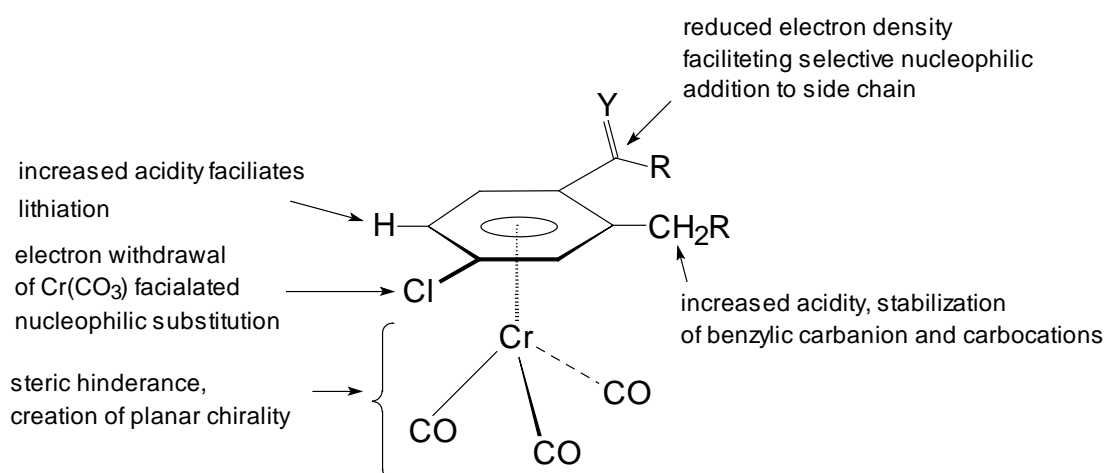
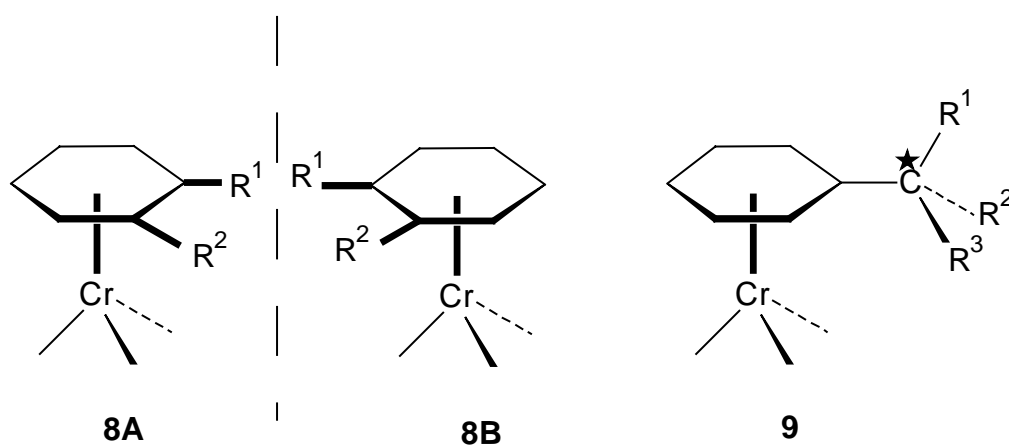

Fig.1: Effect of co-ordination to  $\text{Cr}(\text{CO})_3$  on arene reactivity.

The most significant changes in the reactivity of arene ligands after complexation at  $\text{Cr}(\text{CO})_3$  include: a) increased susceptibility to nucleophilic attack,<sup>25</sup> b) increased acidity of the ring protons,<sup>26</sup> and those in benzylic position c) enhanced solvolytic properties,<sup>27</sup> and d) stereodirecting effect.<sup>28</sup>

One of the significant changes after complexation of prochiral arenes is the planar chirality of the complexes, which is exploited for new methods for organic asymmetric synthesis. Chromium carbonyl complexes with an unsymmetrically disubstituted ring e.g. **8A** and **8B** are planar chiral. In contrast, in **9** the central chirality comes from the ligand bearing an asymmetric carbon atom. One of the advantages working with chromium complexes is that the metal fragment can be easily removed after the desired product has been obtained.<sup>28a</sup>



Compounds like **8** are important since these planar chiral complexes can be used as sources for synthesis of optically active compound.<sup>29</sup> However, the scope of their use is at present limited because of the difficulties encountered in the resolution of racemates. So far in *o*-disubstituted planar chiral (arene)tricarbonyl chromium benzaldehyde complexes and a few other classes can be efficiently resolved.<sup>30</sup> Tricarbonylchromium complexes of *ortho*-substituted benzyl alcohol **10** derivatives were kinetically resolved by asymmetric esterification with lipase.<sup>31</sup> The lipase reacts with the (*S*)-enantiomer of **10** giving **12** in excellent enantioselectivity, leaving the *R*-enantiomer **11** unchanged.

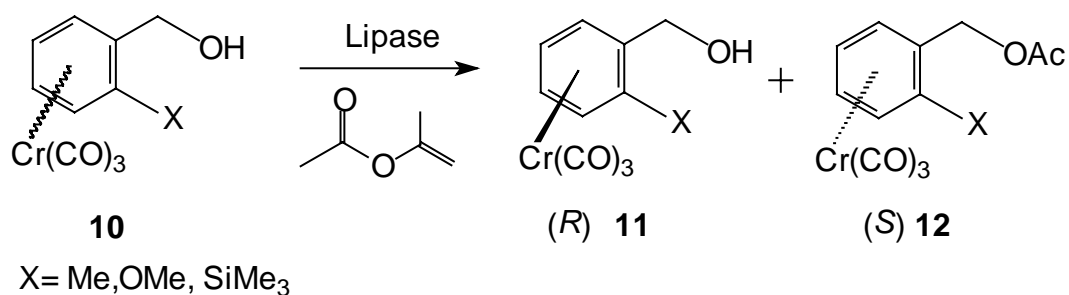

Metal complexation at one face of an aromatic ring in arene tricarbonylchromium complexes permits excellent stereocontrol in reactions at aromatic or benzylic position,<sup>32</sup> the reagent preferentially approaching from the face opposite to the metal (*anti*-addition). Sarkar et al.<sup>33</sup> found that exclusive *anti*-addition with respect to the chromium carbonyl moiety by two different nucleophiles at a position three carbon atoms away from the complexed aromatic ring. Therefore the steric bulk of a chiral Cr(CO)<sub>3</sub> compound offers quite promising possibilities for asymmetric synthesis. Recently, this asymmetric synthesis methodology has been used for synthesis of either the skeleton of natural products or the total synthesis of natural products. Natural products like analog of the cytotoxic marine diterpene heliopirin C,<sup>34</sup> (-)-steganone and O,O'-dimethylkorupensamine A<sup>35</sup> were synthesized successfully using the Cr(CO)<sub>3</sub> for asymmetric synthesis.

The mytomycin families of antitumour antibiotics have attracted considerable attention due to their unique chemical structures and antiproliferative activity.<sup>36a</sup> A common skeleton for this family is that of substituted mitosenes. Jones et al.<sup>36b</sup> prepared the derivatives of tricyclic mitosene (**14**) and reduced its Cr(CO)<sub>3</sub> complexes stereoselectively. Mitosene (**14**) was prepared stereoselectively starting from indole (**13**). The reduction of the pyrrole C<sup>1</sup>-C<sup>2</sup> double bond followed by direct complexation gave **16** in excellent yield. Alternatively, direct complexation of **14** could also be effected in high yield. Metalation followed by addition of methoxymethyl chloride resulted an *exo* product **15** exclusively which shows that metal carbonyl facialiated the electrophiles to approach from the  $\alpha$  face. After stereoselective reduction of **16** with sodium triacetateborohydride **17** and **18** were obtained in 8/92 ratio, respectively.



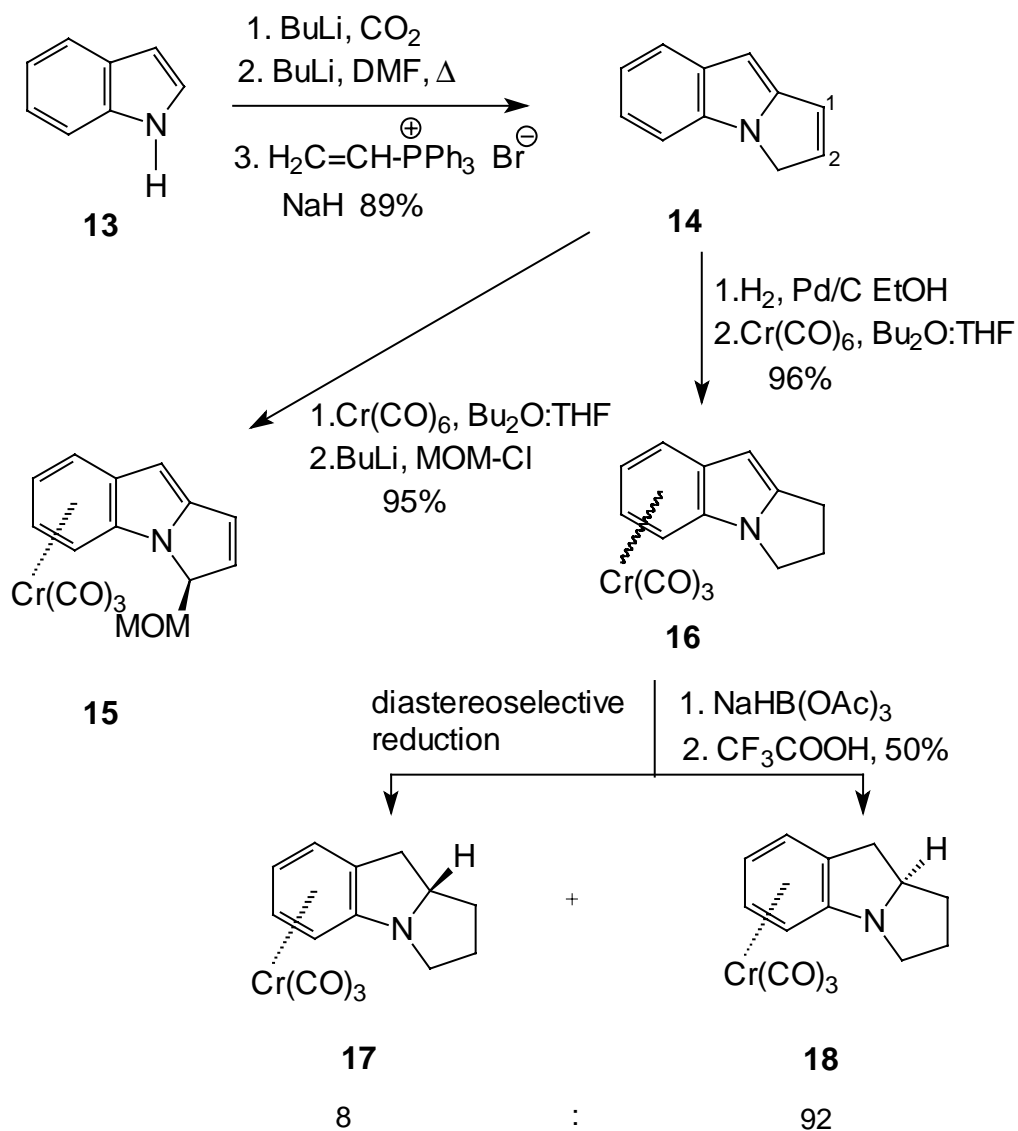

T. Higa and coworkers have isolated and identified a group of bioactive diterpenes from blue coral *Heliopora coerulea* which are named the helioporins.<sup>37a</sup> One compound of this family called helioporin D shows antiviral activity. Schmalz et al.<sup>37b</sup> have synthesized the putative helioporin D (**26**) enantioselectively exploiting arene-Cr(CO)<sub>3</sub> chemistry.

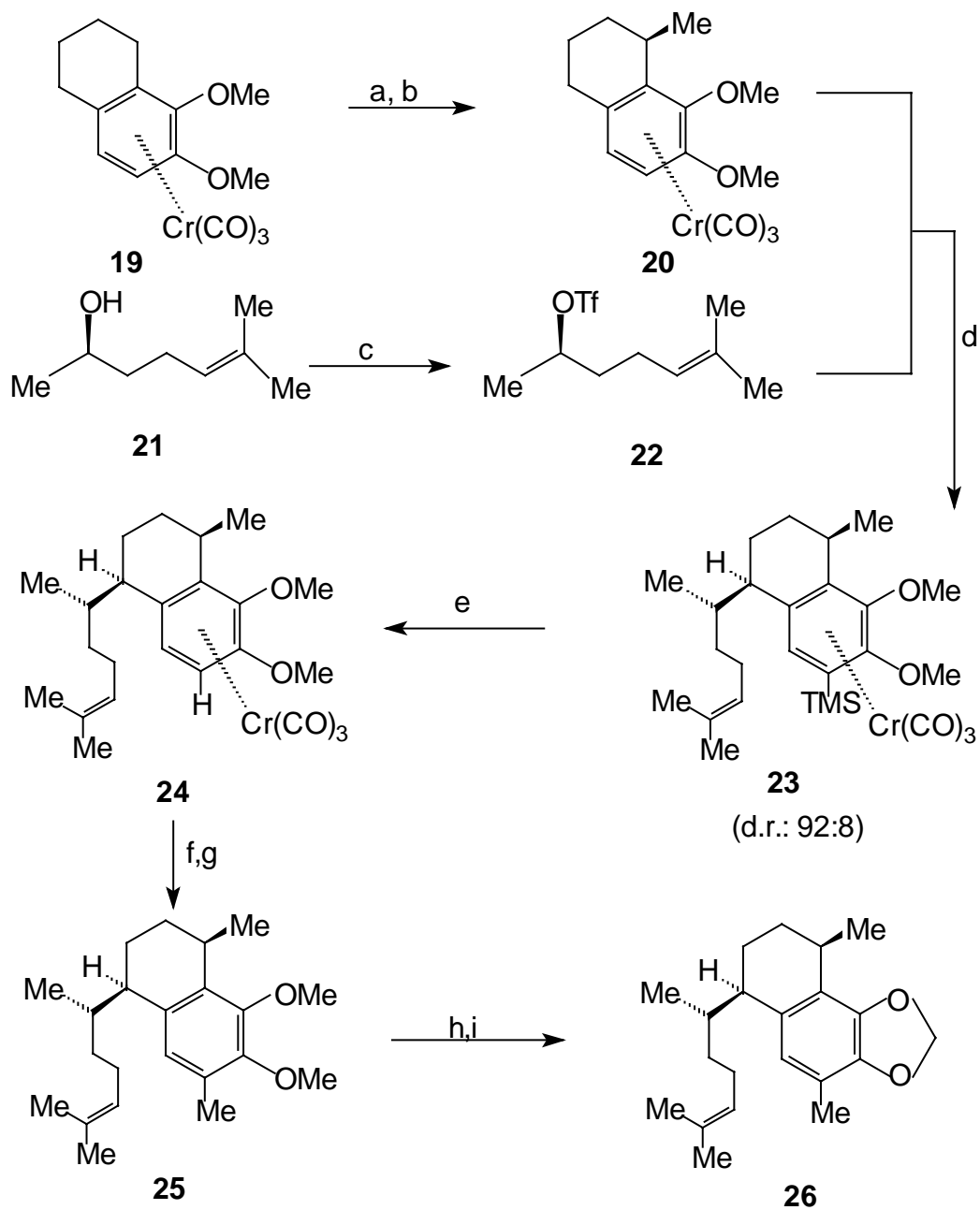

a) BuLi, THF,  $\text{Me}_3\text{SiCl}$  (91%); b) BuLi, THF, MeI (93%); c) BuLi, hexane,  $0^\circ\text{C}$ ,  $\text{Tf}_2\text{O}$  in  $\text{CH}_2\text{Cl}_2$ ,  $-20^\circ\text{C}$ ; d) *s*-BuLi, THF,  $-70^\circ\text{C}$  to  $-20^\circ\text{C}$ , (85%); e) TBAF, THF,  $0^\circ\text{C}$  (100%); f) BuLi, THF,  $-70^\circ\text{C}$  to  $-20^\circ\text{C}$ , MeI, (95%); g) air, sunlight, ether (100%); h) LiSEt, DMF (95%); CsF,  $\text{CH}_2\text{Cl}_2$ , DMF, (88%).

Complex **23** was prepared starting from enantiopure **19** and **21**, which had been transformed to **20** and **22**. **23** contains approximately 8% of an undesired diastereomer. After desilylation of **23** the undesired isomers could be separated by chromatography to get **24** as a pure diastereomer. After *ortho*-lithiation/methylation and decomplexation, compound **25** was obtained which were treated with LiSEt and CsF/DMF, the target molecule **26** was obtained overall 45% yield.

Alkoxy substituents on arenes direct proton abstraction to the *ortho*-position with high regioselectivity, apparently due to a combination of inductive effects and specific coordination of the base (lithium counter ion) with the alkoxy substituents.<sup>38</sup> The lithiation of the ligand of **27** with *tert*-butyllithium was not only regioselective for the *ortho*-position but also diastereoselective. In this reaction, the chelating effect like in **28**, plays a significant role for the diastereoselectivity which causes formation of the *ortho* electrophilic addition product **29**.<sup>39</sup> The alternative would have led to a less stable intermediate with methyl directing to Cr(CO)<sub>3</sub>.

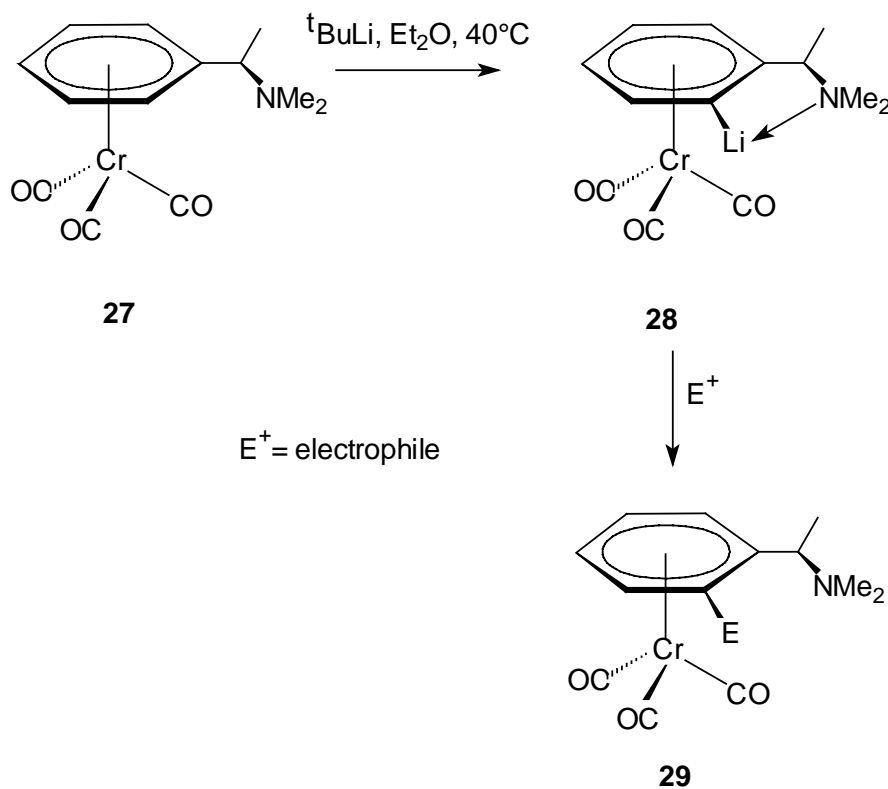

As explained above the complexation of ligands with chromiumcarbonyl changed the chemistry of the ligands as compared to uncomplexed ones.<sup>40</sup> In this context it was one of our interests to exploit the chemistry of the benzocyclobutenone and benzocyclobutenedione after the complexation of these ligands at chromium carbonyl.

The benzocyclobutenone chromium complex **32** can be obtained by refluxing the acetal of benzocyclobutene ligand **30** and hexacarbonylchromium in the 10:1 mixture of dibutyl ether/THF. After the acidic work up of the complexed acetal **31** of benzocyclobutene leads to the racemic benzocyclobutenone complex **32**.<sup>41,42</sup>

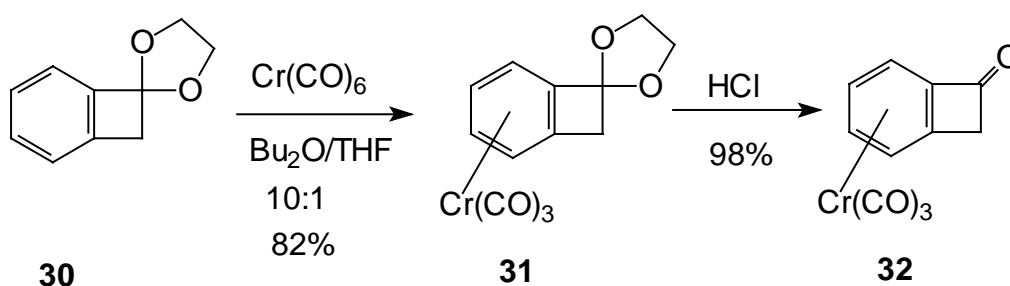

Compound **32** is easily reduced by lithium aluminum hydride under mild reaction conditions at low temperature ( $-78^\circ\text{C}$ ), which is more than  $100^\circ\text{C}$  lower than that used for the corresponding reduction of the uncoordinated 1-oxobenzocyclobutene. The reduction of **32** is completely diastereoselective. In the reduction it was assumed that hydride attacked from the face opposite to the bulky chromium carbonyl group so that only *endo* product **33** was obtained in *de* > 99%.<sup>42</sup>

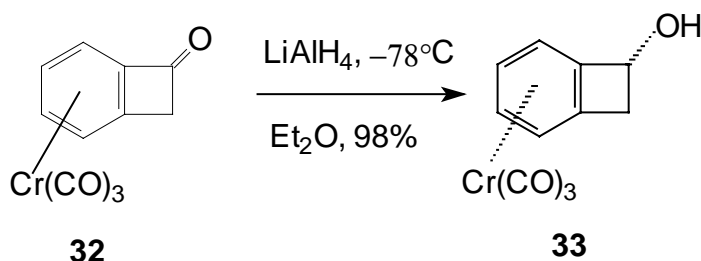

Deprotonation of alcohol **33** with BuLi at  $-78^{\circ}\text{C}$ , formed **34** which leads to an oxy-anion driven ring-opening forming an *ortho*-quinodimethane intermediate **35**, which can be trapped by a dienophile to give various tetralin complexes like **36** via [4+2] cycloaddition diastereoselectively in high yield.<sup>42</sup>

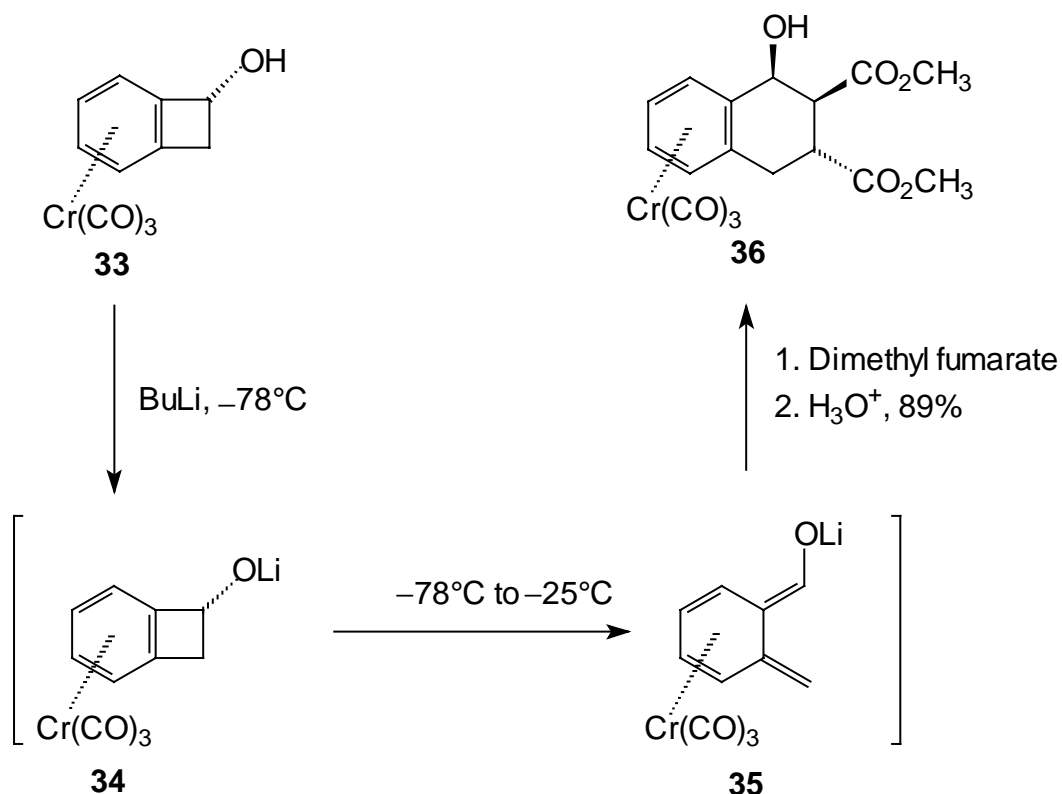

There are many interesting reactions from this benzocyclobutenone complex which have been investigated in last 10 years by Butenschön et al.<sup>44, 68,97</sup>

When butyllithium is added to either the *syn* or the *anti* benzocyclobutenol chromium complex under mild reaction conditions a planar chiral *ortho*-quinodimethane complex intermediate is formed which reacts with a dienophile highly stereoselectively from the face opposite to the metal carbonyl.<sup>45</sup>

The high potential of the benzocyclobutenone complex can be extended by insertion of a second keto group in the four-membered ring so that its reactivity is increased as a result of added strain and coplanarity of the electron-deficient arene ring. The benzocyclobutenedione tricarbonylchromium complex **37** was treated

with excess of vinyl lithium at  $-78^{\circ}\text{C}$ . The vinyl addition took place at both carbonyl groups from the face opposite to the chromium carbonyl group giving *cis*-diadduct **38** which underwent a dianionic oxy-Cope rearrangement forming eight membered ring **39**. After hydrolysis of **39**, benzocyclooctenedione complex **40** is obtained in high yield.<sup>46</sup> Such a dianionic oxy-Cope rearrangement was unknown in the uncomplexed system, and it must be pointed out that such a dianionic oxy-Cope rearrangement is a direct consequence of the complexation of the benzocyclobutenedione to the tricarbonylchromium group, because it causes the diaddition to effectively take place at low temperature exclusively in a *cis* manner.<sup>47,107</sup>

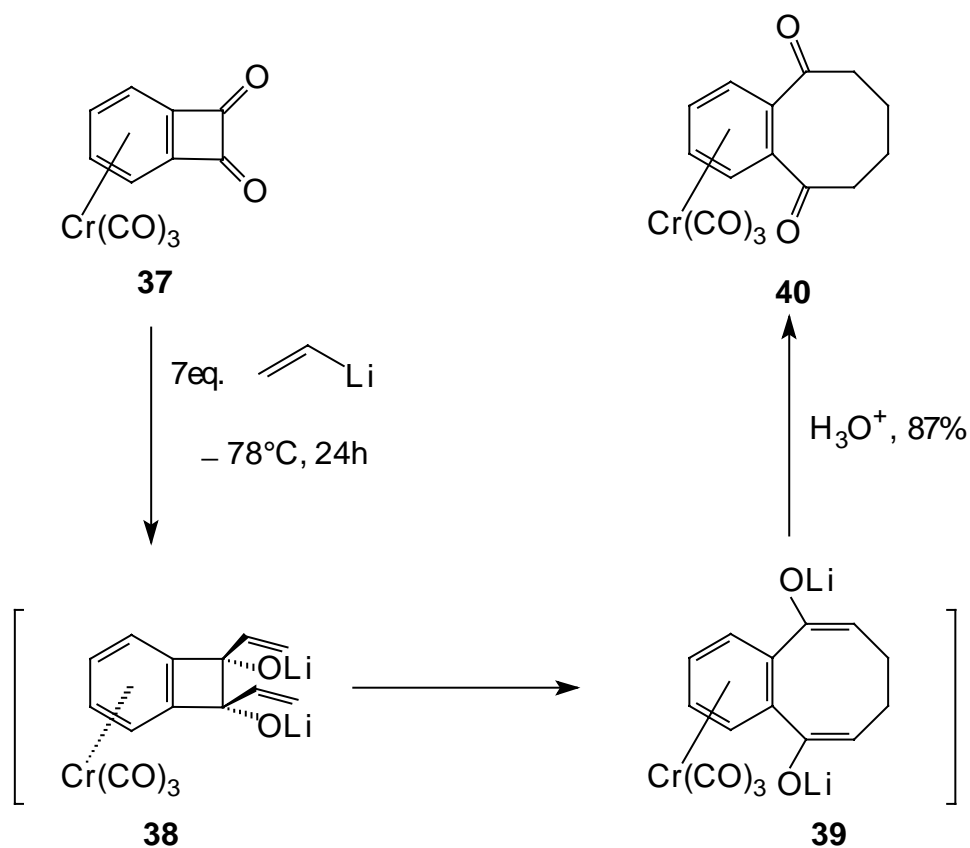

In many cases the dianionic oxy-Cope rearrangement is followed by an intramolecular aldol addition, which takes place with complete diastereoselectivity. In all cases the enolate moiety attacks the keto group from the face opposite to the chromium fragment. For example, when 2-propyllithium is

used as the alkenyl metal, the tricyclic complex **41** is obtained as the only aldol adduct after treatment with acid.

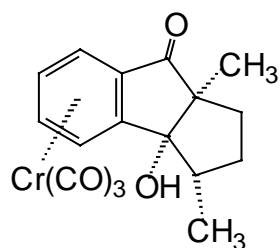

**41**

By this route, and variation of the alkenyl metal used, a large number of tri-, tetra- and even pentacyclic, highly functionalized compounds are accessible in two or three steps from **35** with full diastereoselectivity.

When a methoxy group is substituted at the benzylic ring of **37** the properties of this molecules might be changed. The methoxy substituent at C-3 might influence the chemistry of the complex **42** due to its electron releasing property and because of the reduction of symmetry in the benzocyclobutenedione **42** as compared with **37**.

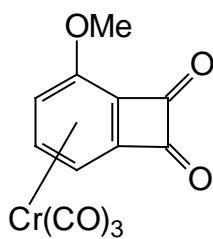

**42**

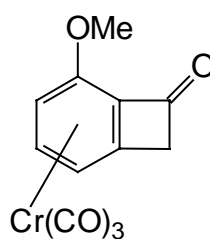

**43**

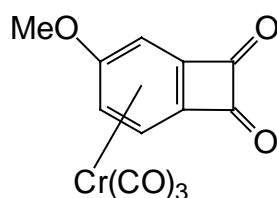

**44**

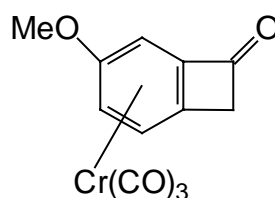

**45**

These aspects are important because the reactivity of the unsubstituted benzocyclobutenone and benzocyclobutenedione complexes **33** and **37** are highly determined by the electrophilicity of keto carbon atom as a result of the electron withdrawal of the Cr(CO)<sub>3</sub> group. It is important to learn to what extent this established reactivity is changed when an electron-rich substituent is attached at the aromatic nucleus in **42** and **43**. In addition, many natural products contain methoxy groups in benzylic position, e.g. podophyllotoxine and its derivatives.<sup>48</sup> Therefore it is interesting to explore the chemistry of these substituted complex system like **42** - **45**.



## B. Results and Discussion

### 2.1 Synthesis of Substituted Benzocyclobutenone and Benzocyclobutenedione

There are many procedures available for the preparation of benzocyclobutenone in the literature. All these methods can be categorized into two main groups: ring closing reactions<sup>49, 50</sup> and cycloaddition reactions.<sup>51</sup> However, one of the efficient and remarkably regioselective syntheses of substituted benzocyclobutene is a [2+2] cycloaddition between benzyne and 1,1-diethoxyethene.<sup>52</sup> 2-Bromoanisole (**46**) was treated with sodium amide, benzyne intermediate **47** was formed, and in the presence of 1,1-diethoxyethene [2+2] cycloadduct **48** was regioselectively obtained in 68% yield. From **48** after treatment with 1M HCl, benzocyclobutenone **49** was obtained in 98% yield.<sup>52</sup>

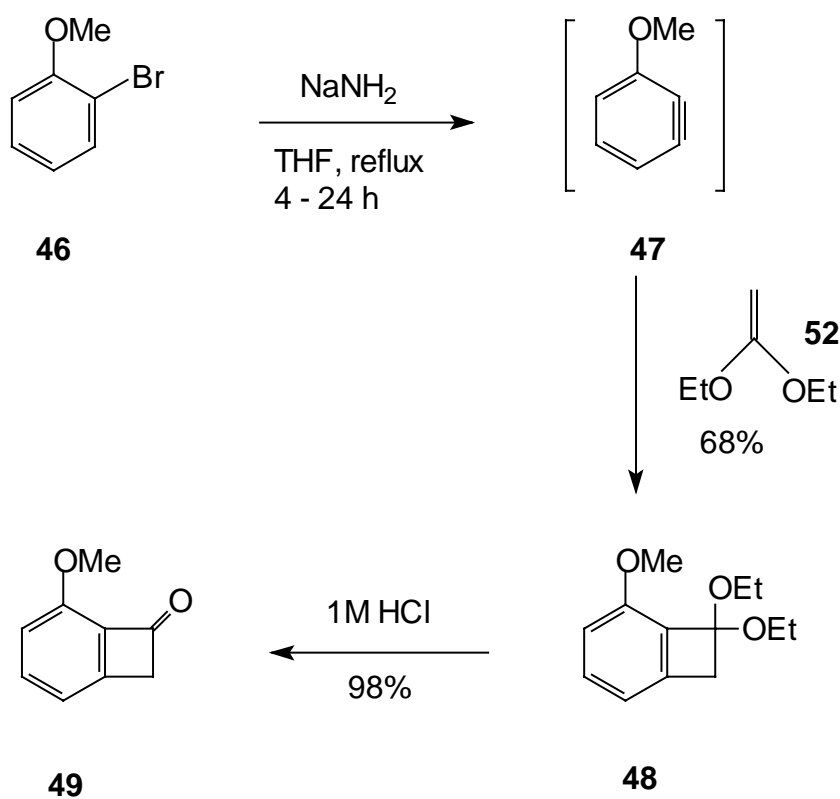

1,1-diethoxyethenylene (**52**) was prepared<sup>53</sup> by 1,4 elimination of hydrogenbromide from 1,1-diethoxy-2-bromoethane (**51**) by dry potassium *tert*-butoxide in *tert*-butanol. After complete distillation of *tert*-butanol in 7 to 10 hours, the colorless liquid **52** is obtained in 68% yield. The 1,1-diethoxy-2-bromoethane (**51**) was prepared from bromination of vinyl acetate (**50**) in the presence of ethanol.<sup>54</sup>

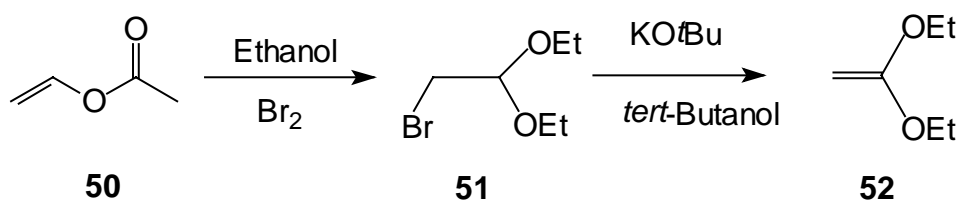

Like in the preparation of benzocyclobutenone, there are many methods for the preparation of substituted benzocyclobutenediones in the literature; both, thermal pyrolysis<sup>55</sup> and [2+2] cycloaddition.<sup>56</sup> Liebenskind *et al.*<sup>57</sup> have synthesized benzocyclobutenedione starting from 2-bromoanisole. In 1989 the same authors<sup>58</sup> published a new method of the synthesis of substituted benzocyclobutenediones starting from the corresponding benzocyclobutenone. Methoxy Substituted benzocyclobutenedione **54** was prepared by hydrolysis of 2,2-dibromobenzocyclobutene **53** with 50% sulfuric acid. The 2,2-dibromobenzocyclobutene **53** was prepared by radical bromination of benzocyclobutenone **49** with *N*-bromosuccinimide (NBS) in presence of a catalytic amount of dibenzoyl peroxide (DBP) refluxing in carbon tetrachloride for 2 to 5 days.

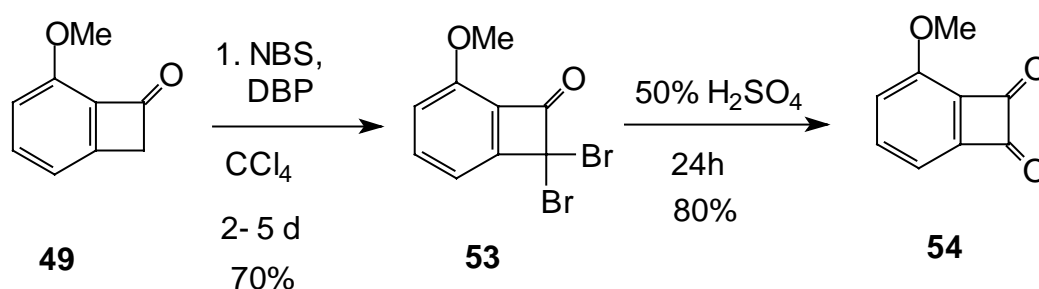

## 2.2 Synthesis of Tricarbonyl( $\eta^6$ -6-methoxybenzocyclobutene)chromium (0) (43)

Tricarbonyl( $\eta^6$ -1-oxobenzocyclobutene)chromium (0) can be prepared by direct complexation; however direct complexation of unsubstituted benzocyclobutenone by refluxing with hexacarbonyl chromium, resulted in a poor yield, and the complexation of 1-oxobenzocyclobutene with triammoniumtricarbonylchromium failed.<sup>44</sup>

Direct complexation of methoxy substituted benzocyclobutenone **49** was performed by refluxing in a sealed tube the methoxy substituted benzocyclobutenone **49** with Kündigs complexation reagent (chromium tricarbonyl naphthalene complex) in THF. The desired complex was obtained in 31% yield.<sup>59</sup> The higher yield as compared to the unsubstituted complex in which the yield was 20% by using the same process might be the effect of methoxy group at aromatic ring. An electron donating group like methoxy at the aromatic ring increases the complexation rate and the yield.<sup>60</sup> However this direct complexation does not seem to contribute significantly to the preparation of substituted benzocyclobutenone complex since the yield is still less than in the complexation with acetal of benzocyclobutene **48** and moreover benzocyclobutenone was prepared from its acetal derivative. The easier way for synthesizing the complexed substituted benzocyclobutenone was complexation of 1,1-diethoxybenzocyclobutene **48** with hexacarbonylchromium by refluxing in 10:1 Bu<sub>2</sub>O/THF. The yield of this complexation was 71% yield.<sup>61</sup> After hydrolysis with 50% HCl, the desired tricarbonyl ( $\eta^6$ -6-methoxybenzocyclobutene) chromium (0), (**43**) was obtained in 92% yield as an orange solid.

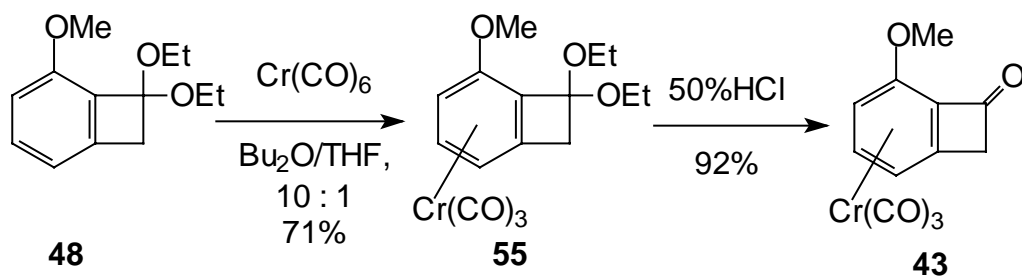

This was crystallized from diethyl ether and hexane to obtain crystals suitable for a crystal structure analysis (fig 2).

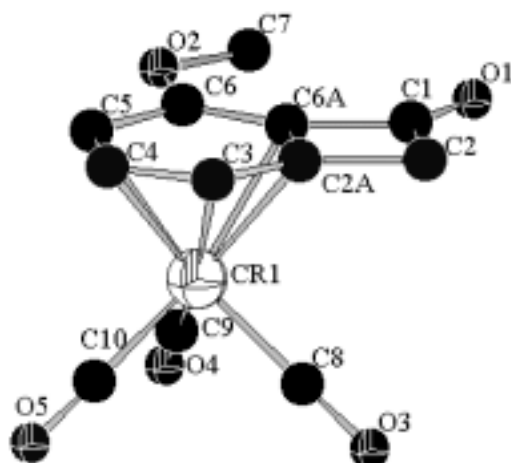
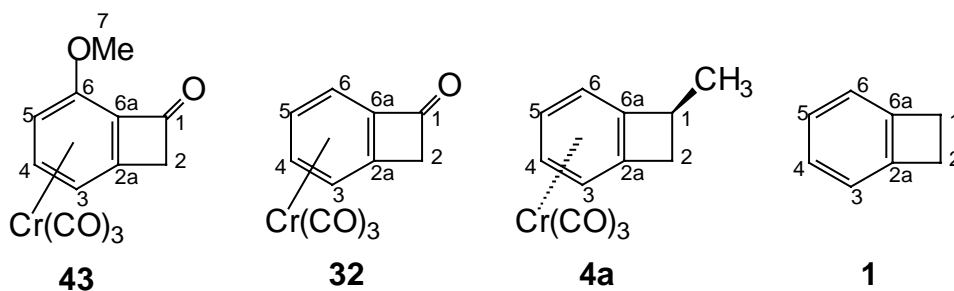

Fig. 2.: Structure of **43** in the crystal

Bond Angle in °			
C1 - C2 - C2a	85.08(17)	C2 - C2a - C6a	94.31(19)
C2a - C6a - C1	90.50(18)	C6a - C1 - C2	90.08(18)

Bond Length in Å			
Cr - C2a	2.181(2)	C1 - C2	1.556(4)
Cr - C3	2.234(2)	C1 - C6a	1.502(3)
Cr - C4	2.173(2)	C2 - C2a	1.523(3)
Cr - C5	2.221(2)	C2a - C3	1.387(4)
Cr - C6	2.310(19)	C2a - C6a	1.428(3)
Cr - C6a	2.225(2)	C3 - C4	1.411(3)
Cr - C8	1.839(3)	C4 - C5	1.415(3)
Cr - C9	1.859(2)	C5 - C6	1.410(3)
Cr - C10	1.843(2)	C6 - C6a	1.417(3)



Comparison of bond lengths of different benzocyclobutene complexes in Å				
Atom No.	43	32 <sup>68</sup>	4a <sup>62</sup>	1
C1 - C2	1.556(4)	1.55(2)	1.576(3)	1.576(1)
C2 - C2a	1.523(3)	1.54(2)	1.521(3)	1.518(1)
C1 - C6a	1.502(3)	1.41(2)	1.525(3)	1.518(1)
C2a - C6a	1.428(3)	1.41(2)	1.407(3)	1.391(1)
C2a - C3	1.387(4)	1.34(2)	1.390(3)	1.385(1)
C3 - C4	1.411(3)	1.37(2)	1.405(4)	1.400(1)
C4 - C5	1.415(3)	1.45(2)	1.399(4)	1.399(1)
C5 - C6	1.410(3)	1.36(2)	1.414(4)	1.400(1)
C6 - C6a	1.217(3)	1.37(2)	1.385(3)	1.385(1)
C1 - C7	-		1.512(4)	-

This is the first crystal structure of the 6-methoxybenzocyclobutenone complex **43**. The complex **43** showed only small changes of the bond lengths in the carbon framework of the arene ligand compared with uncomplexed **1**, unsubstituted complex **32** and complex benzocyclobutene derivatives **4a**. The torsion angle  $C3-C2a-C6a-C1 = 179.6(2)^\circ$ ;  $C6-C6a-C2a-C2 = -177.67(19)^\circ$  showed that the four membered ring is nearly planar to the aromatic ring.

A comparison of the bond length in the above table clearly indicated that some of the variation in the bond lengths, specially the bond  $C_{6a}-C_1$ ,  $C_3-C_4$  and  $C_6-C_{6a}$ . The  $C_{6a}-C_1$  length bond for **1**, **4a**, **32** and **43** are 1.518(1), 1.525(3), 1.41(2) and 1.502(3) Angstrom respectively. In this case for the bond lengths of **1**, **4a** and **43** significant differences were not found, however, the same bond length in complex **32** was 0.1 Å less than other complexes **1**, **4a** and **43**. This might be the effect of the electron withdrawing carbonyl group. Similarly, the  $C_6-C_{6a}$  bond length for **1**, **4a**, **32** and **43** are 1.385(1), 1.385(3), 1.37(2) and 1.217(3) in Å respectively.

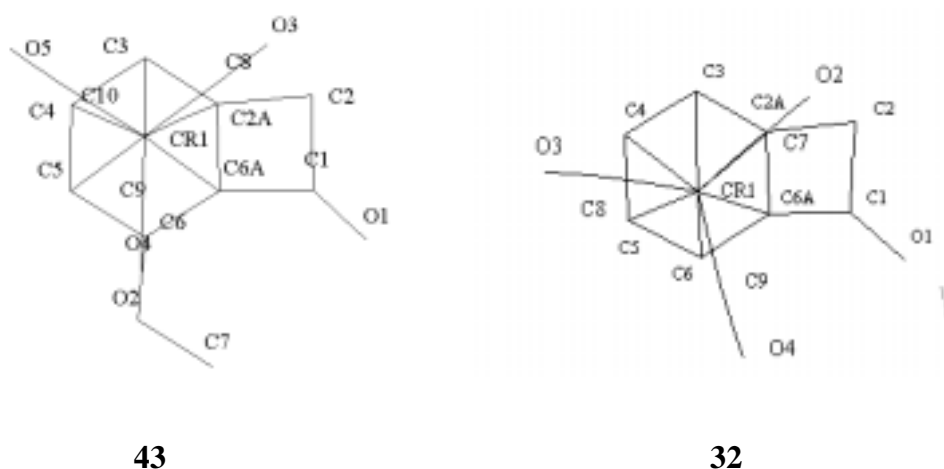

Fig:3 The crystal view from the top of the chromium carbonyl.

The methoxy group is bent towards the cyclobutene ring and the non of the carbonyl group of chromium was under the four membered ring both in methoxy substituted complex **42** and unsubstituted complex **32**. This indicates that the

orientation of carbonyl group in chromium do not effect by the methoxy substituted at the aromatic ring.

### 2.3 Synthesis of Tricarbonyl ( $\eta^6$ -3-methoxybenzocyclobutenedione)-chromium (0)

Direct complexation of 3-methoxybenzocyclobutenedione **54** is more difficult and even less yielding than the 6-methoxybenzocyclobutenone **49** since it contains one more electron withdrawing carbonyl group which results in less electron density at the aromatic ring of benzocyclobutenedione **54**. Therefore the substituted benzocyclobutenedione complex was prepared by the same method used for the preparation of the unsubstituted benzocyclobutenedione complex.<sup>46</sup> The two carbonyl groups of benzocyclobutenedione were first protected by acetalization. 3-methoxybenzocyclobutenedione **54** and glycol were refluxed in the presence of a catalytic amount of *p*-toluenesulfonic acid in benzene using a water extractor for about 5 days. The bisacetal compound **56** was obtained in 69% yield. The complexation of bisacetal **56** was achieved by refluxing it with chromiumhexacarbonyl in a 10:1 mixture of dibutyl ether and THF for about 20 hours while passing a constant argon flow. The yellow bisacetal complex **57** was obtained in 78% yield as a racemic mixture. After hydrolysis with concentrated HCl for 3 h, it changed color from yellow to dark red. After purification tricarbonyl( $\eta^6$ -3-methoxybenzocyclobutenedione)chromium (0) (**42**) was obtained as a dark-red solid in 82% yield.<sup>61</sup>

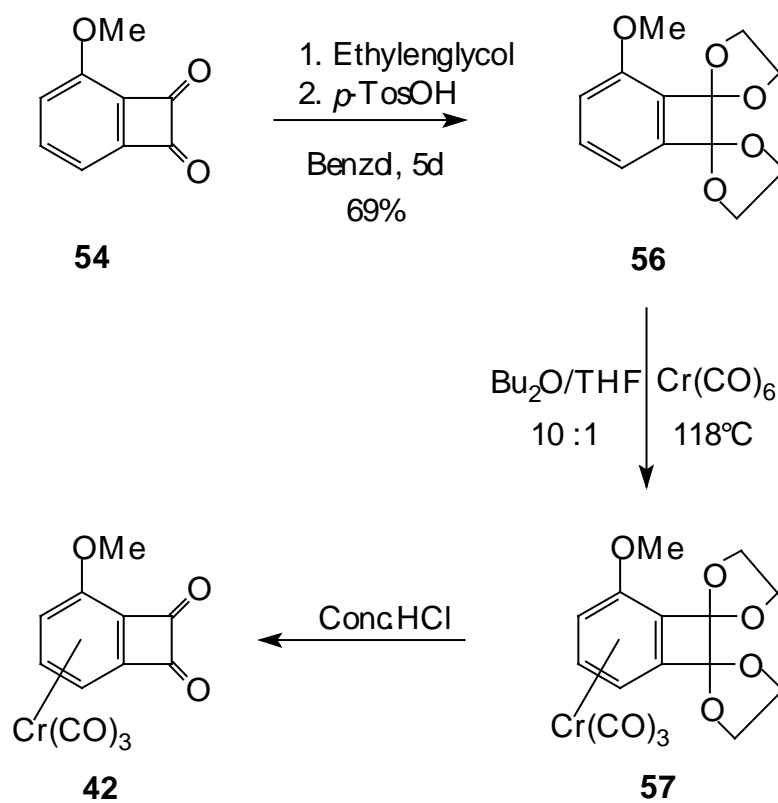

This was crystallized from dichloromethane and diethyl ether to obtain suitable for X-ray structure analysis (fig. 4).

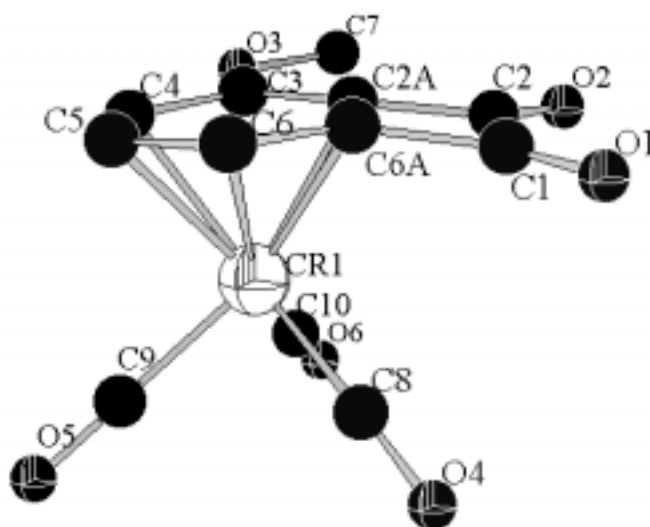

Fig 4: Structure of **42** in the crystal



<b>Bond Length in Å</b>			
Cr - C2a	2.177(3)	C1 - C2	1.561(4)
Cr - C3	2.311(3)	C1 - C6a	1.498(4)
Cr - C4	2.239(3)	C2 - C2a	1.510(4)
Cr - C5	2.196(3)	C2a - C3	1.412(3)
Cr - C6	2.215(3)	C2a - C6a	1.431(4)
Cr - C6a	2.122(3)	C3 - C4	1.398(4)
Cr - C8	1.850(3)	C4 - C5	1.409(4)
Cr - C9	1.868(3)	C5 - C6	1.403(4)
Cr - C10	1.852(3)	C6 - C6a	1.393(4)

<b>Bond Angle in °</b>			
C1 - C2 - C2a	87.2(2)	C1 - C6a - C2a	92.6(2)
C2 - C1 - C6a	87.8(2)	C2 - C2a - C6a	92.3(2)
C3 - O3 - C7	117.9(2)		

<b>Torsion Angle in °</b>			
C1 - C2 - C2a - C6a	0.9(2)	C1 - C2 - C2a - C3	-168.2(4)
C2 - C1 - C6a - C2a	0.9(2)	C2 - C1 - C6a - C6	168.1(4)
C1 - C2a - C3 - C4	-161.8(3)	C6a - C6 - C5 - C4	-2.9(4)
C2a - C3 - C4 - C5	5.6(4)	C2 - C2a - C3 - C4	161.9(4)

The 3-methoxybenzocyclobutendione complex **42** was characterized by <sup>1</sup>H NMR and <sup>13</sup>C NMR only. However after getting the first crystal structure of it, the formation of this complex was confirmed. This crystal gave some important information about electronic, physical and chemical characteristics. The most important information was the comparison of the crystal structures of methoxy substituted and the unsubstituted complex so that the effect of the methoxy group at the aromatic ring can be calculated. The comparison of some bond lengths of these two complexes were explained as follow:

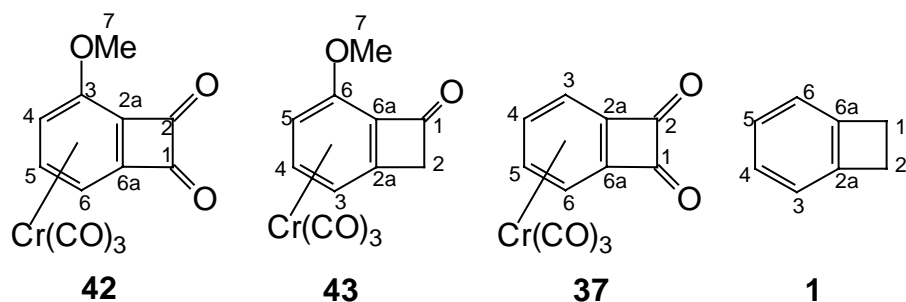

Atom No.	42	43	37 <sup>46</sup>	1
C1 - C2	1.561(4)	1.556(4)	1.566(7)	1.576(1)
C2 - C2a	1.510(4)	1.523(3)	1.504(6)	1.518(1)
C1 - C6a	1.498(4)	1.502(3)	1.507(6)	1.518(1)
C2a - C6a	1.431(4)	1.428(3)	1.418(3)	1.391(1)
C2a - C3	1.412(3)	1.387(4)	1.407(3)	1.385(1)
C3 - C4	1.398(4)	1.411(3)	1.399(4)	1.400(1)
C4 - C5	1.409(4)	1.415(3)	1.410(4)	1.399(1)
C5 - C6	1.403(4)	1.410(3)	1.399(4)	1.400(1)
C6 - C6a	1.393(4)	1.217(3)	1.407(3)	1.385(1)

The bond lengths in the methoxy substituted complex **42** and the unsubstituted complex **37**<sup>46</sup> do not differ significantly. The two conjunction angles of four member ring C1-C2-C2a = 87.2(2) and C2-C1-C6a = 87.8(2)°; C1-C6a-C2a = 92.6(2)° and C2-C2a-C6a = 92.3(2)° are similar which indicates that the cyclobutene ring is not distorted. However, the lengths of four bonds in cyclobutene ring are not similar. The bond which joined two carbonyl group [C1-C2 = 1.564(4) Å] is longer than the bond which fixed with the aromatic ring [C6a-C2a = 1.431(4) Å] by 0.13 Å. This might be the presence of electron withdrawing carbonyl groups at C-1 and C-2. From this data it clearly indicated that the cyclobutenete ring in not exactly the rectangular but little expanded as shown in fig. **42a**. A similar difference was also found in the case of the unsubstituted complex.<sup>46</sup>

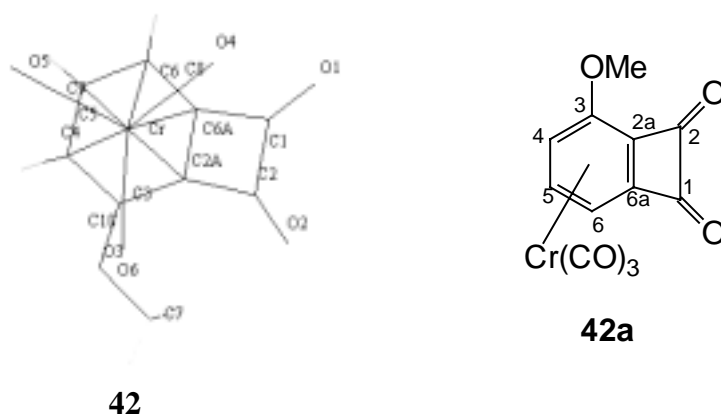

Fig.5: The crystal views from the top of the chromium carbonyl.

The bond length of C6a -C1 = 1.498(4) Å and C2-C2a = 1.510(4) Å while these bond lengths in unsubstituted complex **37** are exactly similar. This might be the electronic effect of the methoxy group at aromatic ring. The torsion angle C3-C2a-C6a-C1 = 172.2(2); C6-C6a-C2a-C2 = 171.8(3). This indicates that the cyclobutene ring is bent from the plane of aromatic ring by 8° toward the side of chromium. The methoxy group was bent toward the four membered ring and non of the carbonyl groups lies below the four membered ring.

### 3. Reduction of Tricarbonyl( $\eta^6$ -6-Methoxybenzocyclobutenone)-chromium (0) (**43**)

#### 3.1 Reduction of **43** with Lithium Aluminium Hydride

As explained above in the case of the unsubstituted complex the alcoholate can undergoes distal ring opening to the *ortho*-quinodimethane complex and therefore, the benzocyclobutenone complex should be converted to the corresponding alcohol complex. There are many ways to convert the methoxy substituted benzocyclobutenone complex **43** to 1-hydroxy-6-methoxybenzocyclobutene complex **58**. The simple method is a nucleophilic addition to the carbonyl group of 6-methoxybenzocyclobutenone complex **43**. The methoxy substituted benzo-

cyclobutenone complex **43** was treated with lithium aluminum hydride at  $-78^{\circ}\text{C}$  for about 1h in diethylether. The reduced product tricarbonyl( $\eta^6$ -1-hydroxy-6-methoxybenzocyclobutene)chromium(0) (**58**) was obtained as yellow solid in 98% yield after purification. From the spectral data, it was confirmed that the reduced product **58** was only one diastereomer.

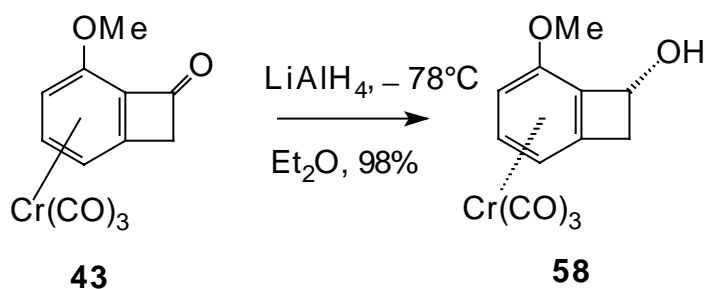

Such a high yield and diastereoselectivity was also observed in the case of unsubstituted complex.<sup>42</sup> The reduction of uncoordinated benzocyclobutenone with lithium aluminium hydride takes place at  $15^{\circ}\text{C}$ , more than  $100^{\circ}\text{C}$  higher than temperature of the reduction of the chromium complex **43**.<sup>63</sup> This indicates an increased reactivity of 6-methoxybenzocyclobutene when coordinated to  $\text{Cr}(\text{CO})_3$ , which can be explained by the electron withdrawing effect of the  $\text{Cr}(\text{CO})_3$  fragment. The electron withdrawal is transferred by the rigidity of the organic ligand causing the ketone  $\pi$  orbital to be originated parallel to the arene  $\pi$  orbital allowing optimal interaction between them. This diastereoselectivity is the effect of the presence of a bulky chromium carbonyl group effectively blocking one face at the complex **43**.

### 3.2 Approaches to Prepare the Enantiomerically Enriched 1-Hydroxy-cyclobutene Complex by Noyori Catalyst

Noyori et al.<sup>64</sup> found that  $\text{Ru}(\text{II})$  complexes modified with an arene and a chiral *N*-tosylated 1,2-diamine serve as efficient catalysts for the asymmetric ketone reduction. This  $\text{Ru}(\text{II})$  catalysis effect a highly enantioselective reaction of

aromatic ketones at room temperature. The stereoselectivity of this reaction was obtained primarily by kinetic discrimination of enantiofaces of prochiral ketones but thermodynamic factors are not negligible. This catalyst has also been used for the reduction of uncoordinated 2,2-dimethoxy-1-indanone.<sup>65</sup> So far it was not tested with more complex compounds. Methoxy substituted benzocyclobutenone chromium complex **43** was treated with catalyst **60** and stirred for about 2 days. The alcohol **58** and starting material ketone **43** was obtained nearly on 1:1 ratio. However the 1-*endo*-hydroxy-6-methoxybenzocyclobutene **58** has only low determined 6 % ee and yield was 46%. However the example of other reaction showed that enantioselectivity could be improved by changing reaction condition or reaction medium.

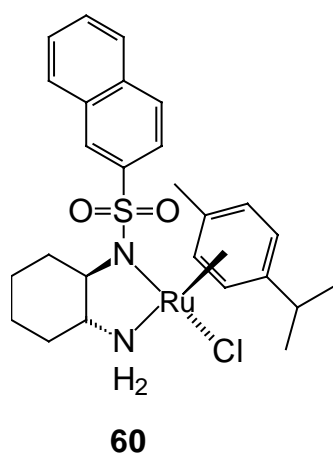
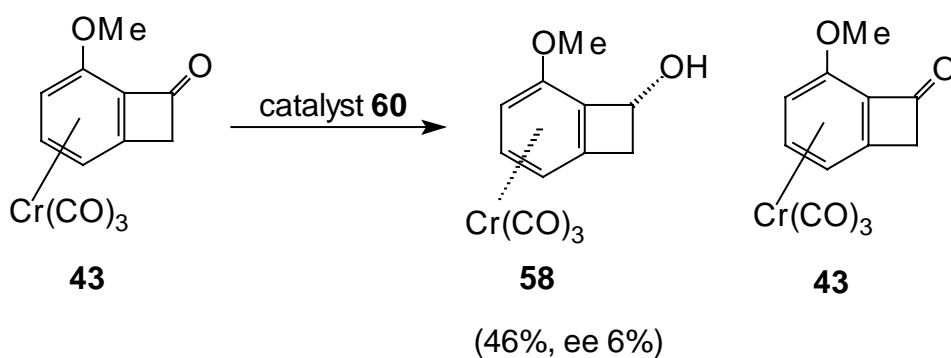

## 4 Addition of Carbon Nucleophiles to Tricarbonyl( $\eta^6$ -6-methoxybenzo-cyclobutenone)chromium (0) (**43**)

### 4.1 Grignard Reagents Addition

The benzocyclobutenone complex system might be a more promising substrate for nucleophilic addition reactions as compared to the uncoordinated system. It was expected that the conformational rigidity of the organic ligand in combination with the steric bulk of the metal fragment would lead to substituted hydroxybenzocyclobutene complexes with high diastereoselectivity. Moreover, the planarity of the benzocyclobutene ligand permits an ideal transfer of the electron density to the metal causing a considerable activation of the keto group towards nucleophilic reagents.<sup>46,66</sup> To explore this, Grignard reagents were used for the reaction. The 6-methoxybenzocyclobutenone complex **43** was treated with different Grignard reagents e.g. methyl, vinyl and pentenyl magnesium bromide at  $-78^\circ\text{C}$ . The products **62**, **63**, and **64** were obtained in 98 %, 96 %, and 95 % yield respectively.

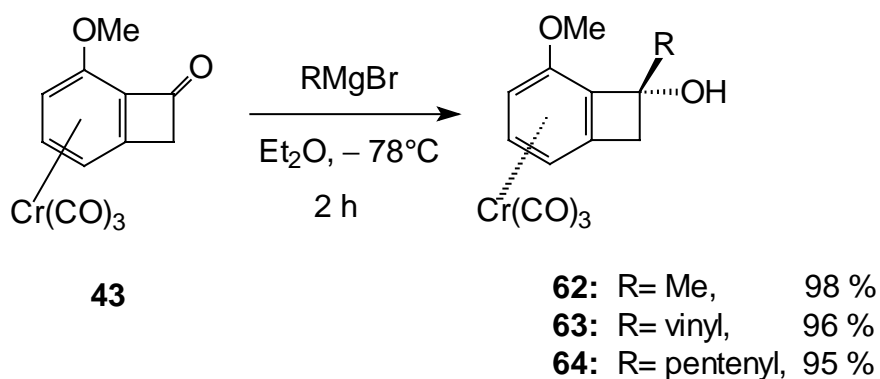

The high yields of the reaction at such a low temperature ( $-78^\circ\text{C}$ ) can be explained as an effect of the chromium carbonyl group. The temperature of such nucleophilic reaction for uncoordinated 1-indanone and 1-tetralone compounds were nearly  $100^\circ\text{C}$  higher<sup>67</sup> than those for the methoxy substituted benzocyclobutenone complex (**43**). NMR spectra of these compounds showed the

presence of only one diastereomer indicating that these reactions were diastereoselective. Such a high yield and diastereoselectivity was also observed in the case of the unsubstituted complex.<sup>44</sup> This shows that the electron donating methoxy group attached to the aromatic ring of the benzocyclobutenone does not exert a significant effect on the reactivity of the keto group in the four membered ring by delivery of electron density.

#### 4.2 Treatment of 1-endo-Hydroxy-1-exo-vinyl-6-methoxybenzocyclobutene Complex (**63**) with Butyllithium

The 1-endo-hydroxy-1-exo-vinyl-6-methoxybenzocyclobutene complex (**63**) was treated with butyllithium at  $-78^{\circ}\text{C}$ , the first deprotonation of the alcohol giving lithium alkoxy intermediate **65** at  $-78^{\circ}\text{C}$ .

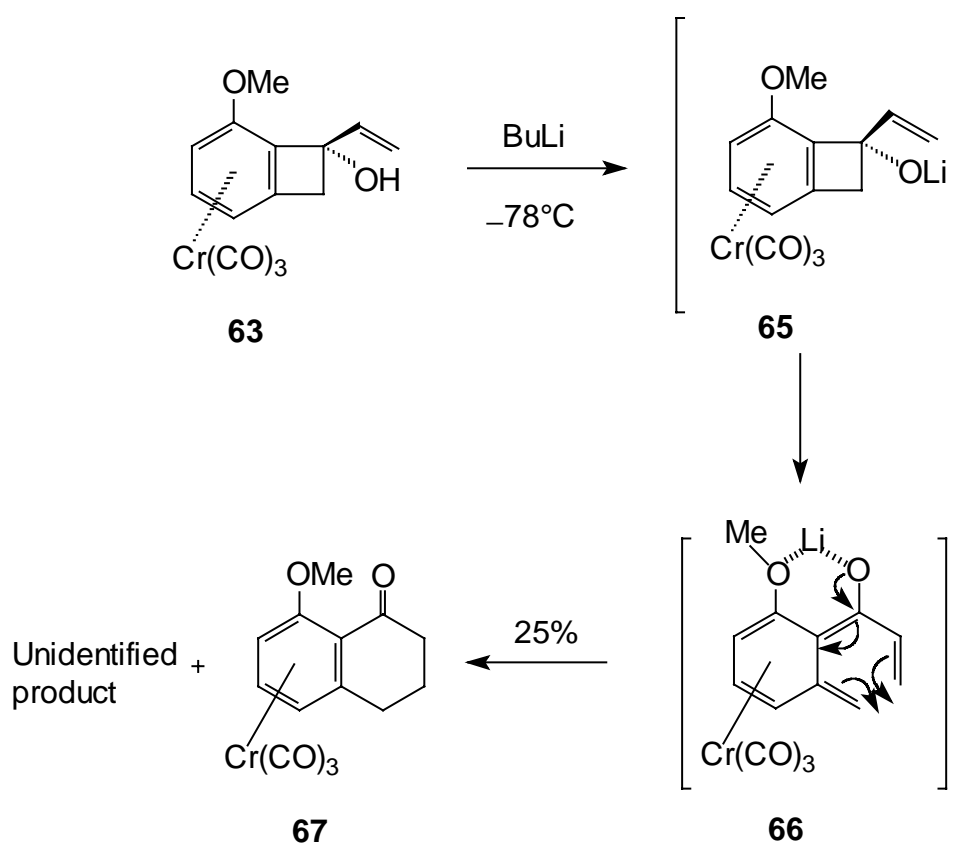

The intermediate **65** undergoes an anion driven ring opening resulting an *ortho*-quinodimethane intermediate **66**, which later electrocyclized giving 1-tetralone complex **67**. Such anion driven 1-vinylcyclobutenol rearrangements are rare. The product **67** was obtained in 25% yield as a yellow solid, and the rest of the product could not be identified. In this reaction, the methoxy group might stabilize the intermediate **66** by chelating with lithium and oxygen so that the anion driven rearrangement will be favored. So far the so-called anionic vinyl benzocyclobutenol rearrangement was known only in few examples in case of the unsubstituted complex e.g. with addition of lithiated methoxyallene.<sup>71</sup> Compound **67** was identified by the spectral data analysis. In IR spectrum, there is strong band at 1699 cm<sup>-1</sup> for the six-membered ring ketone functional group. In the <sup>1</sup>H NMR spectrum, proton signals at  $\delta = 1.97, 2.71$  and 3.00 show that the product was neither a ring opening product nor a normal adduct like **63**, these are the signals for aliphatic proton which gives the evidence for the complex **67**. The <sup>13</sup>C NMR spectrum also gives evidence for the six-membered aliphatic ring. From the comparison of these data with those of the uncoordinated ligand,<sup>72</sup> it was concluded that the product is  $\alpha$ -tetralone complex. The <sup>1</sup>H MNR spectrum of rest fraction was the complicated signals so that the products could not be identified.

### 4.3 Addition of Alkenyl and Alkynyllithium to the Complex **43**

To explore the anionic rearrangement reaction, 6-methoxybenzocyclobutenone complex **43** was treated with lithiated trimethylsilyl acetylene. However, the result was not as expected, and only the proximal ring opened product **68** was obtained in 86% yield.



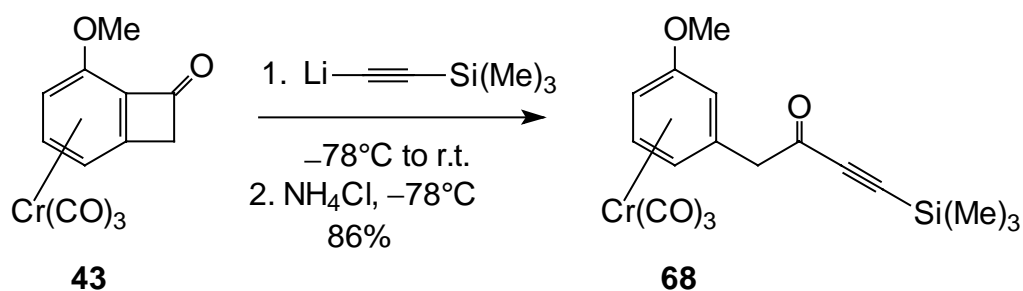

The benzocyclobutenone complex **43** was further treated with 1-cyclopentenyllithium to explore the so-called vinyl anion rearrangement. However, no rearrangement product was obtained and only proximal ring opening product **69** was obtained in 89% yield.

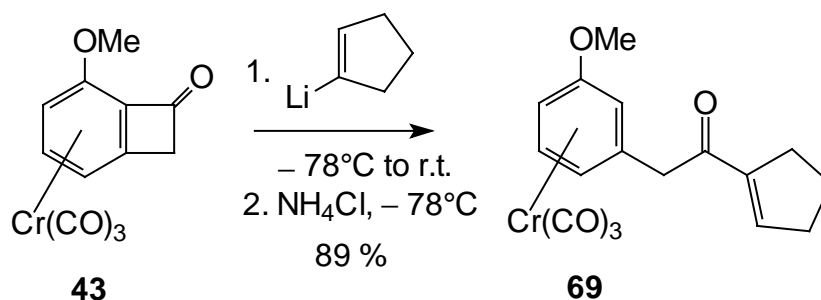

In the case of the addition of vinyl lithium to the 6-methoxybenzocyclobutenone complex **43** only proximal ring opening product was observed. Therefore to explore this chemistry in 6-methoxybenzocyclobutenone complex **43**, it was treated with a number of alkyl lithiums e.g. methyl, phenyl and furyl, only the proximal ring opening products **70**, **71** and **72** were obtained in 80 %, 82 %, 92% yield respectively and no addition product like **73** was observed in any of these reactions.

Ziehe<sup>71</sup> found that in the addition of the alkyl lithium to the unsubstituted complex **32** at  $-78^\circ\text{C}$ , the ring opening product was favored in longer reaction time while the addition product was favored in shorter reaction time.<sup>71</sup> In contrast, by keeping the same conditions in the reaction of the 6-methoxybenzocyclobutenone complex **43**, no addition product was obtained.

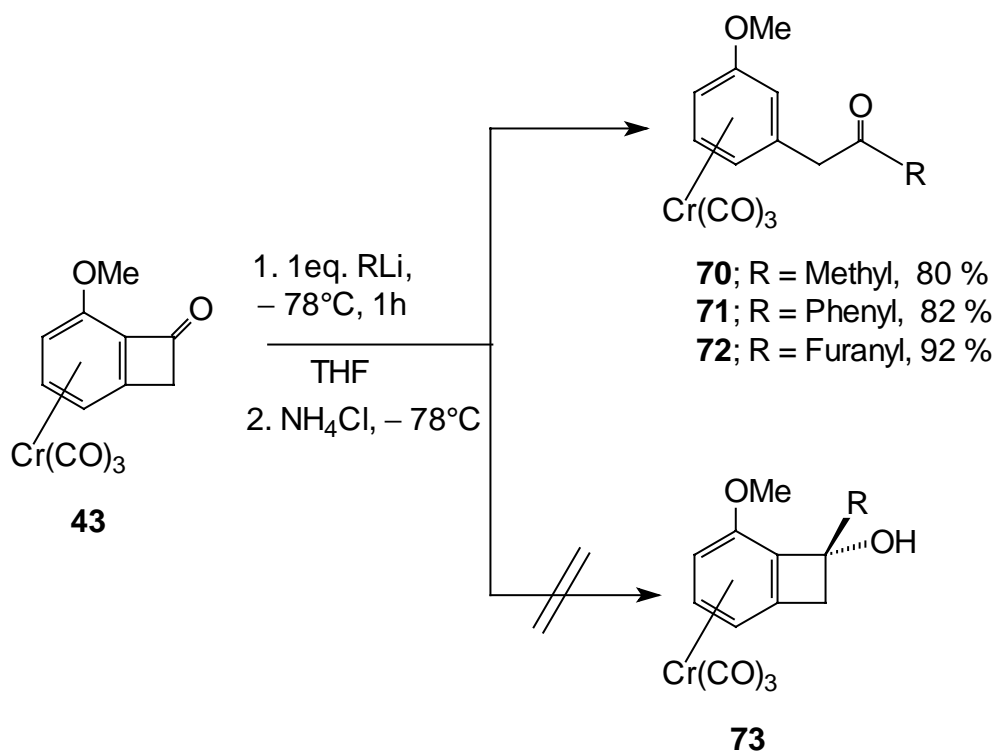

When two equivalents of Alkyl lithium were treated to the 6-methoxybenzocyclobutendone complex **43**, proximal ring opening followed by double addition to the ketone resulting **74** with furanyl in 89 % and an **75** with phenyl in 80 % yield. Such a reaction are few known in the unsubstituted complex, recently, such two fold addition also observed in unsubstituted complex when added 2 equivalents of lithiated pyrrole was added.<sup>59</sup>

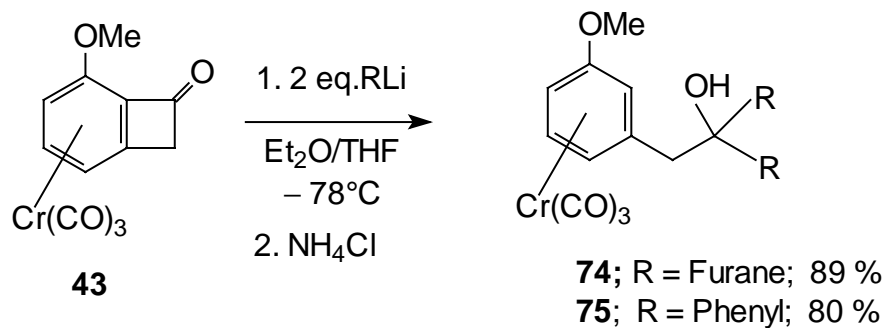

These complexes are very sensitive to acidic medium. When the compound **74** was treated with acid a complex **76** was obtained in 98 % yield as an orange-red solid by elimination of water.

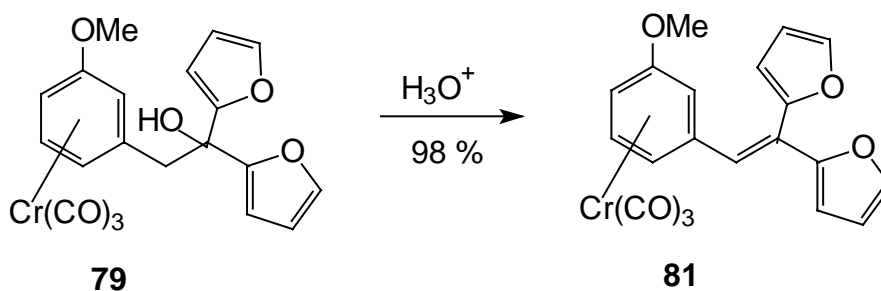

The presence of a double bond in compound **81** might be useful as a precursor for further reactions.

The proximal ring opening in the methoxy substituted complex can be explained by an alcoholate **77**, which is a key intermediate for the unexpected proximal ring opening reaction. The alcoholate **77** undergoes an anion driven distal ring opening forming an *ortho*-quinodimethane **78**, which can equilibrate to another intermediate **79**.<sup>68</sup> In the case of the unsubstituted complex **32**, the intermediate corresponds to these **77** - **79** were considered to equilibrate,<sup>44</sup> and such an anion was stabilized by the electron withdrawing tricarbonyl chromium. In the methoxy substituted complex **43**, it was assumed the equilibrium shifted more towards the intermediate **79** due to the presence of an *ortho* directing methoxy group at aromatic ring. Thus **79** should be more stable than **78**, so that after protonation the proximal ring opening product **80** was obtained as major product.

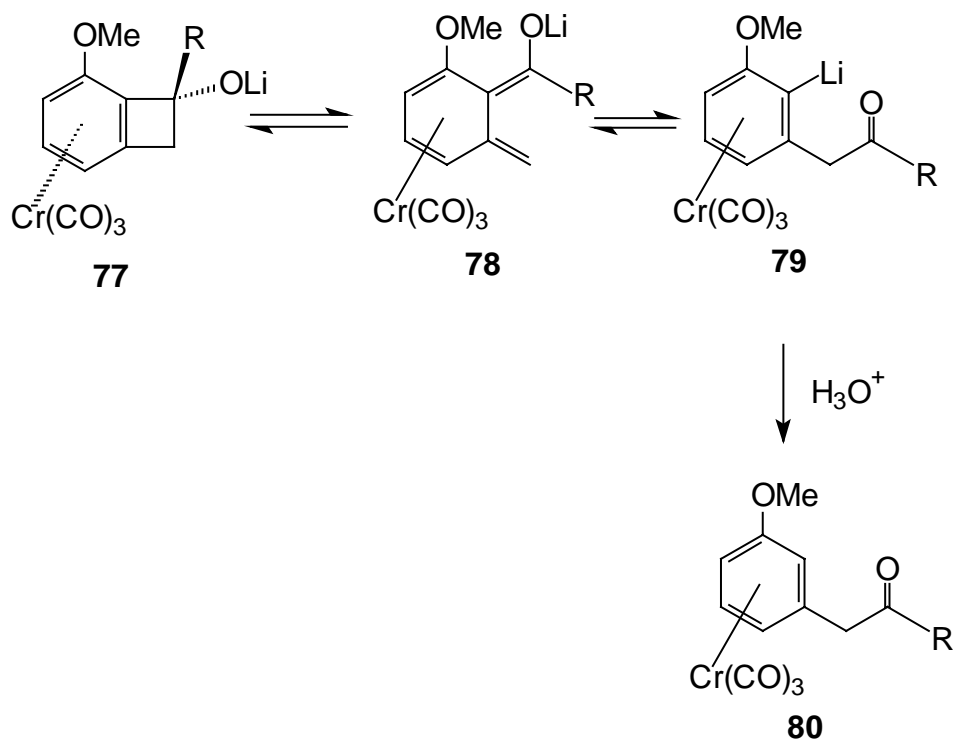

In contrast, such a ring opening product was not obtained with the addition of Grignard reagents at low temperature. This might be the effect of the ring opening temperature. A study of the ring opening temperature at the unsubstituted complex **32**, showed that the ring opening temperature depends on the metal used and magnesium causes a higher ring opening temperature than the lithium.<sup>74</sup>

#### 4.4 Addition of Oxygen and Nitrogen Nucleophiles

The proximal ring opening in 6-methoxybenzocyclobutenone complex **43** might be the effect of a methoxy group present at aromatic ring of the benzocyclobutene complex which normally stabilized a negative charge at the *ortho* position of the aromatic ring. A similar result was also obtained with the uncoordinated 6-methoxybenzocyclobutenone **49** by Gokhale et al<sup>73</sup> when treated with base (MeONa/MeOH), a distal ring opening product **81** and proximal ring opening product **82** was obtained in 0-1% and 99-100% respectively.

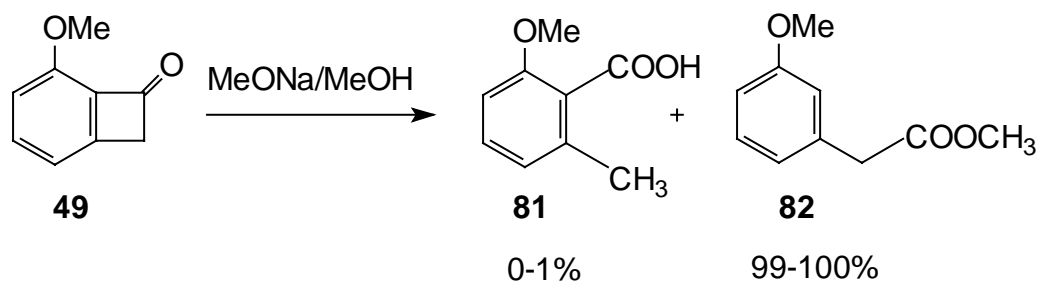

Nitrogen is one of the main elements containing in biologically active alkaloids. Therefore, it was thought to synthesize the nitrogen containing compounds from complex **43** by intramolecular cycloaddition. The 6-methoxybenzocyclobuteneone complex **43** was treated with 4,4-dimethyl-amino-1-pentene (**83**). The mixture was stirred at room temperature for 2 days, and only proximal ring opening product **84** was obtained in 86% yield. This same proximal ring opening was also observed in the unsubstituted complex system too.<sup>44, 97</sup>

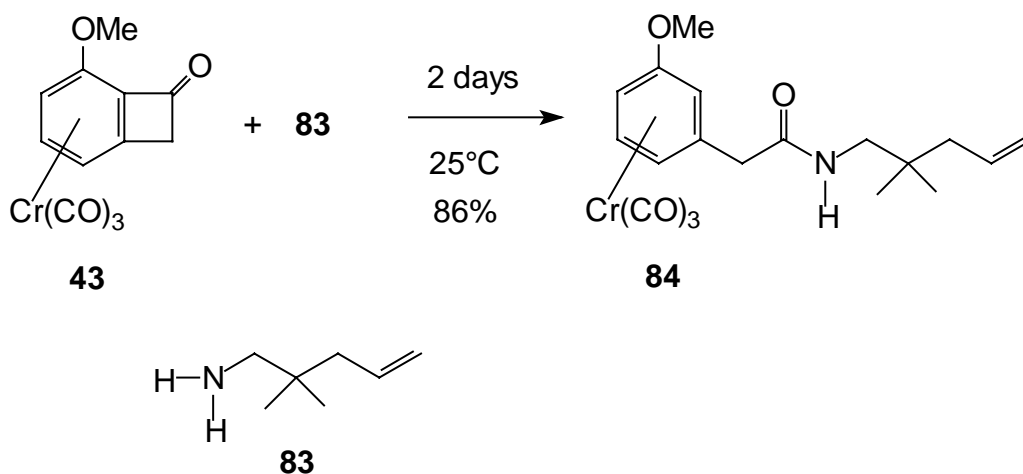

## 5 Anionic Ring Opening of Tricarbonyl( $\eta^6$ -6-methoxycyclobutenol)chromium (0) (**58**) Followed by [4+2] Cycloaddition

### 5.1 Anionic Ring Opening Followed by Cycloaddition in the Unsubstituted Complex

As mentioned in earlier chapters, the uncoordinated benzocyclobutenol easily forms the *ortho*-quinodimethane intermediate by various methods. These intermediates can be trapped in presence of a dienophile resulting the [4+2] Diel-Alder cycloaddition. Such reactions are widely used for the synthesis of natural and medicinal compounds.<sup>13, 17,75</sup> Kündig et al.<sup>43</sup> first synthesized the complex **87** by thermal [4+2] cycloaddition of 1-ethoxy-benzocyclobutene complex **85** and *trans*-1, 2-bis(trimethylsilyl)ethene. At 160°C 1-ethoxybenzocyclobutene complex (**85**) undergoes a distal ring opening resulting in the *ortho*-quinodimethane intermediate **86** which was trapped by dienophile *trans*-bis(trimethylsilyl)ethene forming cycloadduct **87**.<sup>43</sup>

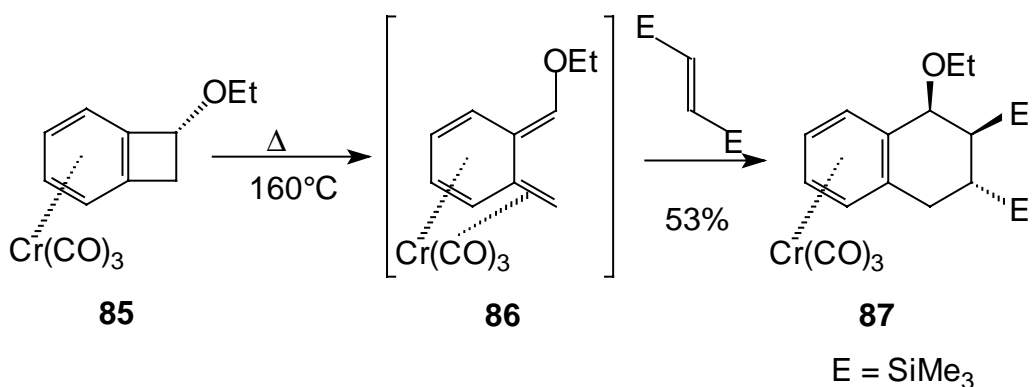

However, the reaction did not appear to represent a general method because the reaction temperature required was very high. Butenschön et al.<sup>42</sup> had first synthesized the tetralin complex **34** from 1-hydroxybenzocyclobutene complex **31** by using the method of Choy and Yang,<sup>76</sup> who found in 1988 that the ring-opening reaction of the uncoordinated ligand was much accelerated if the alcoholic proton was removed. This was the first the cycloaddition reaction of this ligand, which

consisted of the purely anion driven distal ring opening followed by the [4+2] cycloaddition in presence of dienophile.

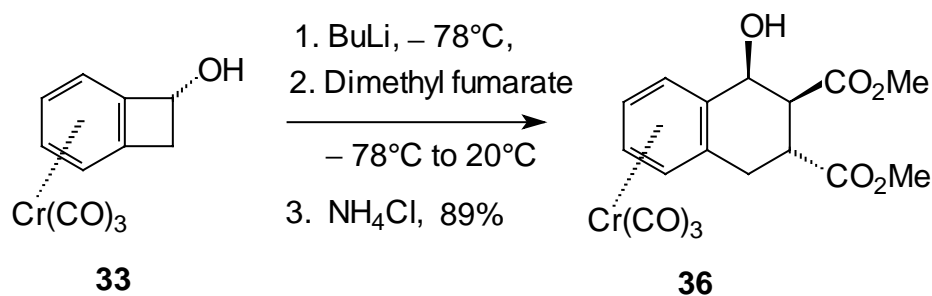

## 5.2 Anionic Ring Opening Followed by [4+2] Cycloaddition in the 1-*endo*-Hydroxy-6-methoxybenzocyclobutene Complex **58**

The introduction of a methoxy group at the aromatic ring of the complex **31** might change the electronic as well as the steric influences. Therefore it was interesting to know whether or not such an anion driven ring opening followed by [4+2] cycloaddition will take place in the methoxy substituted complex **58**. Therefore the 1-*endo*-hydroxy-6-methoxybenzocyclobutenone complex **58** was treated with butyllithium in presence of various dienophiles.

### 5.2.1 Cycloaddition with Methyl Acrylate

Tricarbonyl( $\eta^6$ -1-*endo*-hydroxy-6-methoxybenzocyclobutene)chromium (0) (**58**) was treated with butyllithium at  $-78^\circ\text{C}$ , the color changed from yellow to yellow-orange indicating deprotonation of the alcohol. Then, an excess of methyl acrylate was added to the reaction mixture, a yellow solid mixture of **88** and **89** were isolated in 80 % yield after hydrolysis.

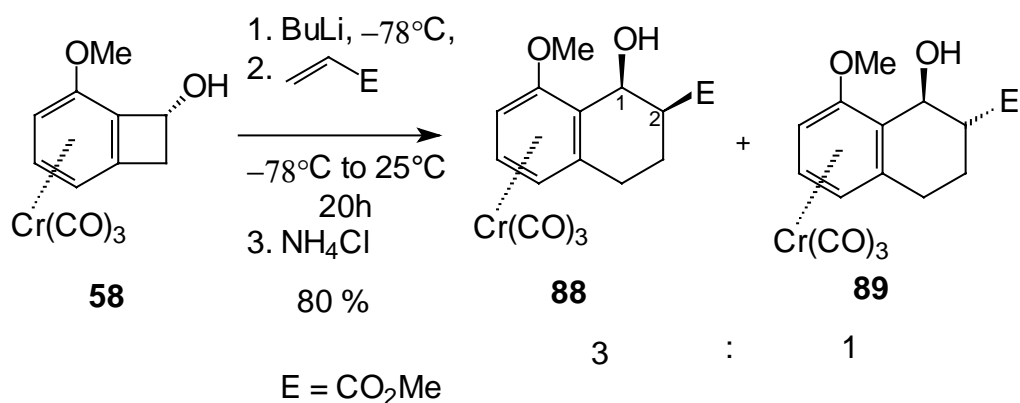

The compounds **88** and **89** were identified by the comparison of their spectra with the corresponding the unsubstituted complex.<sup>42, 43</sup> The spectral data and coupling constant of 1-H indicated the diastereomeric ratio of **88** and **89** to be 3:1.

In this reaction methyl acrylate, attacked exclusively from the *anti* face of the benzocyclobutenone resulting the *endo* cycloadduct as the major product **88**. This can be explained by assuming the torquoselective<sup>77</sup> ring opening of the **90** to be **91**.

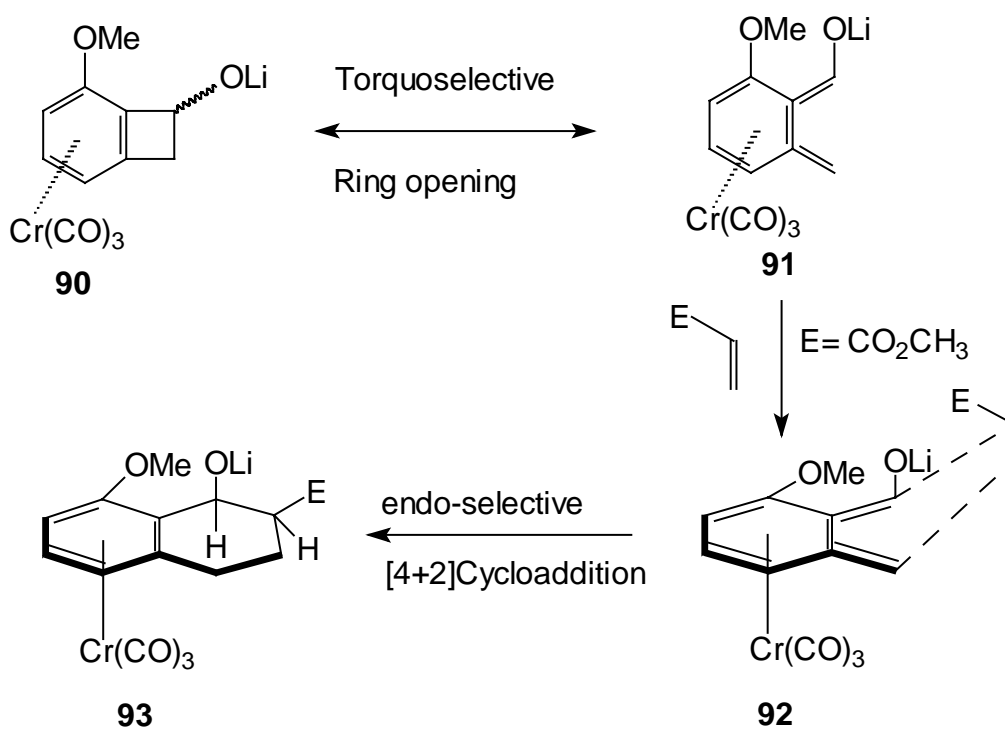



The secondary orbital overlap between the diene and the dienophile via an *endo* transition state appears to be more effective with the electron-rich enolate double bond than with the *exo*-methylene double bond as in the transition state **92**.

Similarly [4+2] cycloaddition of complex **58** was performed with dimethyl fumarate. The 1-hydroxy-6-methoxybenzocyclobutene complex **58** was treated with one equivalent of BuLi at  $-78^{\circ}\text{C}$ , the color changed from yellow to yellow-orange indicating the deprotonation of the alcohol. Four equivalents of dimethylfumarate were added to the reaction mixture, and an orange-yellow compound **94** was obtained in 56 % yield after hydrolysis.

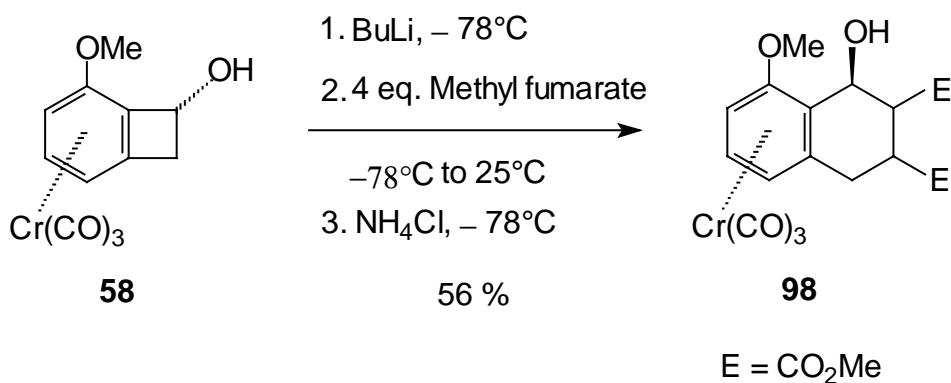

The spectral data especially MS indicated the presence of the complex tetrahydronaphthalene complex **94**. However in the  $^1\text{H}$  NMR spectra, more signals were overlapped in the methoxy region, which made it difficult to interpret the spectra, whether it were single diastereomer product or a diastereomeric mixtures. In many attempts so far the  $^1\text{H}$  NMR and  $^{13}\text{C}$  NMR could not be obtained as clear spectra. In contrast, the cycloaddition of dimethylfumarate with the unsubstituted complex **32** was obtained one diastereomer in high yield.<sup>42</sup>

### 5.2.2 Cycloaddition with vinyl sulfones

So far the cycloaddition with methyl acrylate both in coordinated as well as in the uncoordinated case<sup>80</sup> predominantly or exclusively formed the diastereomer with a 1,2-*cis* configuration in the annellated ring resulting from an *endo* selective [4+2]

cycloaddition. The 1-hydroxy-6-methoxybenzocyclobutene complex **58** was first treated with butyllithium at  $-78^{\circ}\text{C}$ , and then an excess of phenyl vinyl sulfone was added. The yellow complex **95** was obtained in 84 % yield after hydrolysis.

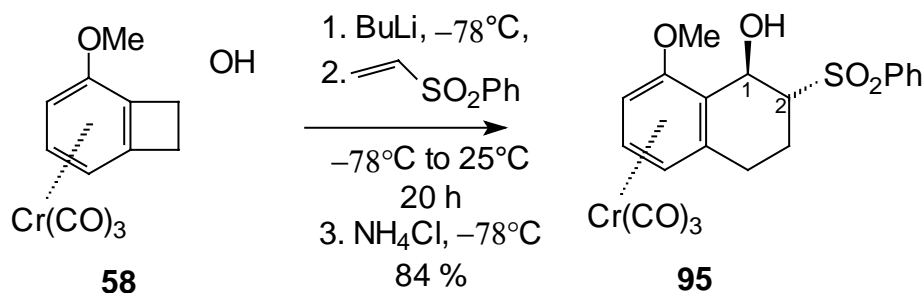

The product **95** was identified by comparing its spectroscopic data with the similar product from the unsubstituted complex<sup>20, 42</sup>. The relative configuration of hydroxyl and sulfone was 1,2-*trans* with  $^3J_{1, 2} = 8.8$  Hz. The 1,2-*trans* configuration between the hydroxyl and the sulfone group was established taking reference from the crystal structure and NMR coupling constant of the unsubstituted complex.<sup>20,42</sup>

The 1,2 *trans* configuration in **95** is remarkable, because in the cycloaddition with methyl acrylate the 1,2-*cis* isomer **88** was formed as the major diastereomer in the unsubstituted case. The *trans* reaction product with vinyl sulfone had not only been obtained in the case of the complex, but also from in the uncoordinated compound.<sup>42</sup> The tetraline **97** was obtained in 59% as one diastereomer by heating **96** at  $110^{\circ}\text{C}$  in the presence of the methyl vinyl sulfone.<sup>42</sup>

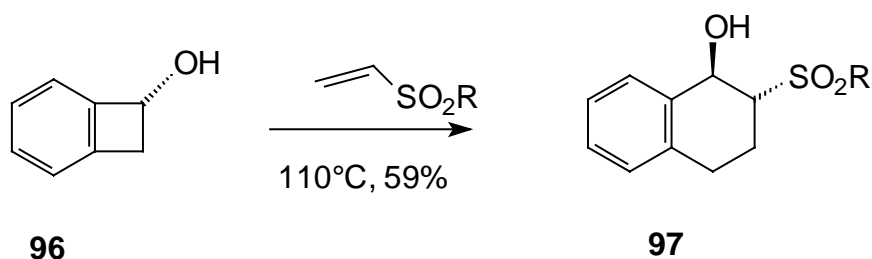

This indicates that the reason for the diastereoselectivity was not a possible pre-coordination to the metal. More likely the diastereoselectivity can be explained taking the steric bulk<sup>81</sup> of the vinyl sulfone group into account. The difference between vinyl sulfones and  $\alpha,\beta$ -unsaturated carbonyl compounds like methyl acrylate is the ability of the latter to form an extended, conjugated, more or less planar  $\pi$  system, which favor the formation of transition state *endo-98*. In contrast, due to the tetrahedral structure of sulfones they can do so with only one of two sulfur-oxygen functionalities. This feature increases the energy of an *endo* transition state with a secondary orbital interaction between the electron-rich diene and the electron-poor dienophile. Consequently the *exo* transition **99** state lacking the electronic as well as the steric interaction is favored. However in case of cycloaddition with vinyl sulfone the *endo-99* was sterically unfavorable due to tetrahedron structure of sulfone group and the transition state *exo-99* was found more favorable for the [4+2] cycloaddition. Therefore in the case of vinyl sulfone an *exo* selective cycloaddition takes place, resulting the 1,2 *trans* configuration **95**.

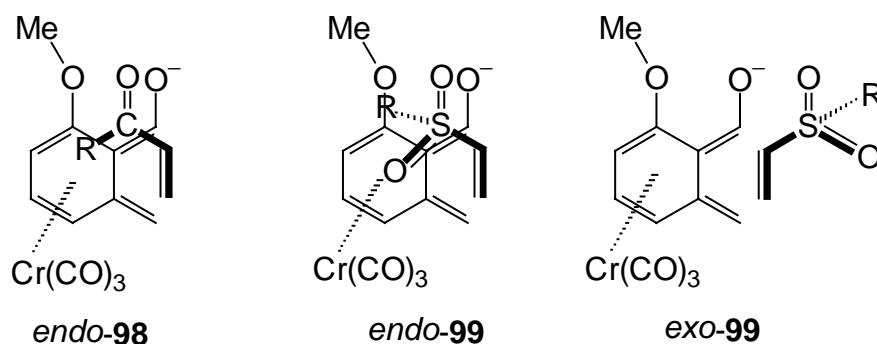

### 5.2.3 Cycloaddition with Dimethyl Butynedionate

The 1-*endo*-hydroxy-6-methoxybenzocyclobutenone complex **58** was treated with BuLi at  $-78^{\circ}\text{C}$ , and dimethyl butendionate was added to the reaction mixture at  $-78^{\circ}\text{C}$  after stirring the 40 min. After hydrolysis, the [4+2] cycloadduct **100** was obtained in 62% yield. The complex could be used for the generating aromatic complex after elimination of water.

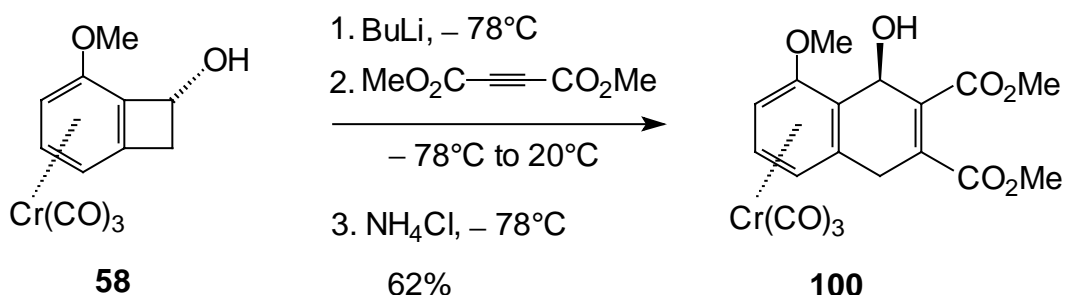

#### 5.2.4 [4+2] Cycloaddition with Tricarbonyl( $\eta^6$ -*endo*-1-hydroxy-*exo*-1-methyl-6-methoxybenzocyclobutene)chromium (**62**)

Complex **62** was prepared aiming at the [4+2] cycloaddition with different dienophiles. This reaction might lead to more diastereoisomeric products because of the methyl group at C-1. However, the methoxy group might cause some chelating effect in the *ortho*-quinodimethane intermediate **102**, which could control the stereochemistry of this reaction to some extent. Complex **62** was treated with butyllithium at  $-78^{\circ}\text{C}$  and added an excess of the methyl acrylate. The product **101** was obtained in 58% yield after hydrolysis.

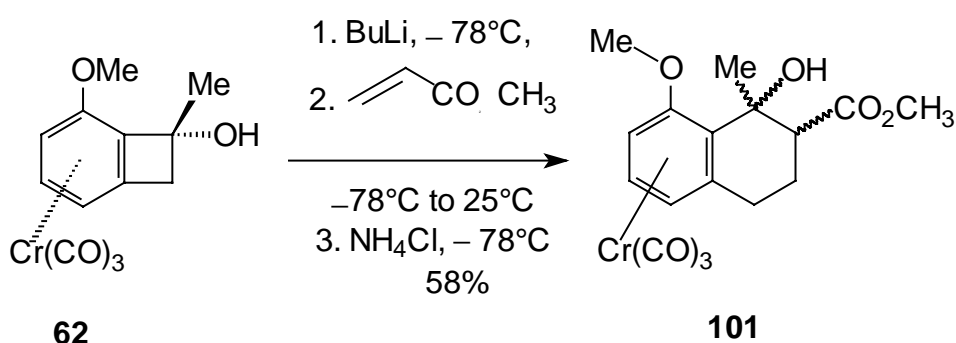

The spectral data especially MS, indicated the presence of the complex tetrahydronaphthalene complex **101**, however, in the  $^1\text{H}$  NMR, the signal were overlap in methoxy, aromatic region, which made difficult to confirm the product

**101** whether it is single diastereomer product with mixture ring opening or a diastereomeric mixture.

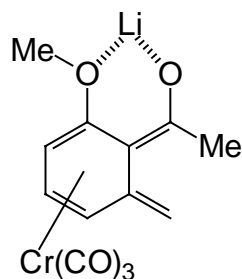

So far in many attempts the  $^1\text{H}$  NMR and  $^{13}\text{C}$  NMR could not be obtained as a clear spectra. It is obvious that due to presence of the methyl group at C-1 position, there are more products as compared to the [4+2]cycloaddition with complex **62** since after the introduction of the methyl group at C-1 the possibilities of formation diastereomers are increased. Moreover the geometry of the methyl group can form in either *E*- form or *Z*- form of the *ortho*-quinodimethane.<sup>84</sup>

It was thought that the chelation effect of the lithium counter ion between the methoxy and the alcoholate plays some role in the control of stereochemistry in the formation of cycloaddition reaction by stabilizing the *Z*-form of the *ortho*-quinodimethane **102**. However, no such chelation effect had play the significant role in the stereocontrol of this reaction.

### 5.3 Proximal ring opening

In order to explore the limitation of the [4+2] cycloaddition reaction with 1-*endo*-hydroxy-6-methoxybenzocyclobutene complex **58**, it was treated with different dienophiles having electron delivering ability like vinyl acetate, ethoxypropyne, maleic anhydride etc. for the [4+2] cycloaddition. However there was no [4+2] cycloadduct observed with any of these dienophile. This indicates that the 6-methoxybenzocyclobutenone **58** did not undergo [4+2] cycloaddition reaction

with such dienophiles. This can be explained either because of the electron rich dienophiles of the dienophile. The substituent in the dienophile plays a significant role on the reactivity of the dienophile and a usual Diels-Alder reaction; the dienophile preferentially is of the electron-poor types having electron withdrawing substituent have a rate enhancing effect.<sup>83</sup>

When the complex **62** was treated first with butyl lithium and an excess of vinyl sulfones (both methyl and phenyl) was added. A ring opening product **103** was obtained in 80% and 85% yields from the [4+2] cycloaddition of phenyl vinyl and methyl vinyl sulfone respectively, after the hydrolysis.

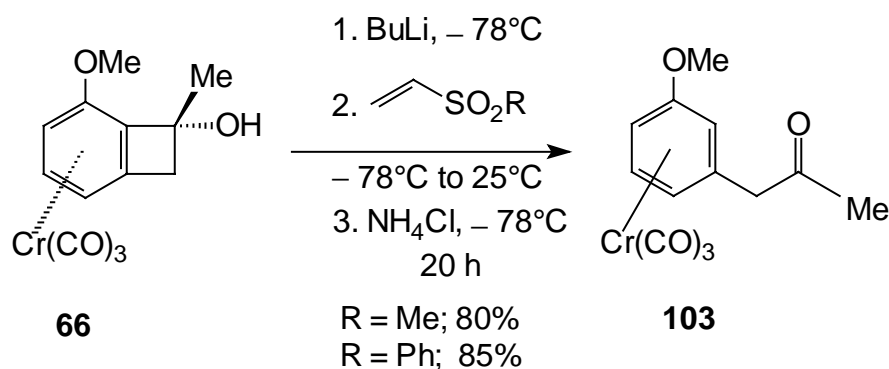

The product was identified by the spectral data analysis. This reaction indicates that there was no [4+2] cycloaddition reaction between **62** and the vinyl sulfones. This might be the effect of steric hindrance of vinyl sulfone. As described in previous chapter, the vinyl group is in tetrahedron so that it is more sterically bulky than the methyl acrylate. Therefore it is sterically unfavored the system to go [4+2] cycloaddition with more crowded complex **62**.

## 5.5 Attempts to an Intramolecular [4+2] cycloaddition from **64**

The 1-*exo*-pentenyl-1-*endo*-hydroxy-6-methoxybenzocyclobutene (**64**) was synthesized with the aim of a two-step transformation of **64** to a tricyclic system via intramolecular cycloaddition reactions. Such an intramolecular cycloaddition

reaction have been widely used for the syntheses of complicated carbon skeletons<sup>86</sup> and total syntheses of steroids.<sup>85</sup> A suitable starting material to perform such a reaction at a coordinated benzocyclobutene has to bear an alcohol function at the four-membered ring so that an anion driven ring opening reaction is favorable, and the number of side chain carbon atoms in the dienophile is also important. Therefore the alcoholate of the hexenyl derivative **64** was selected for the intramolecular cycloaddition. When the complex **64** was first treated with butyllithium at  $-78^{\circ}\text{C}$ , the color changed from yellow to orange-yellow indicating the formation of alkoxide. After hydrolysis, ring opening product **105** was formed in 60 % yield and no desired intramolecular cyclized product **104** was observed. A similar type of reaction was performed in unsubstituted complex with side chain one carbon atom longer than **64**, and only ring opening product was obtained.<sup>44</sup> It was thought that one carbon less can increase the rigidity of the side-chain so that the conformation of the side-chain will favor the intramolecular [4+2] cycloaddition reaction.

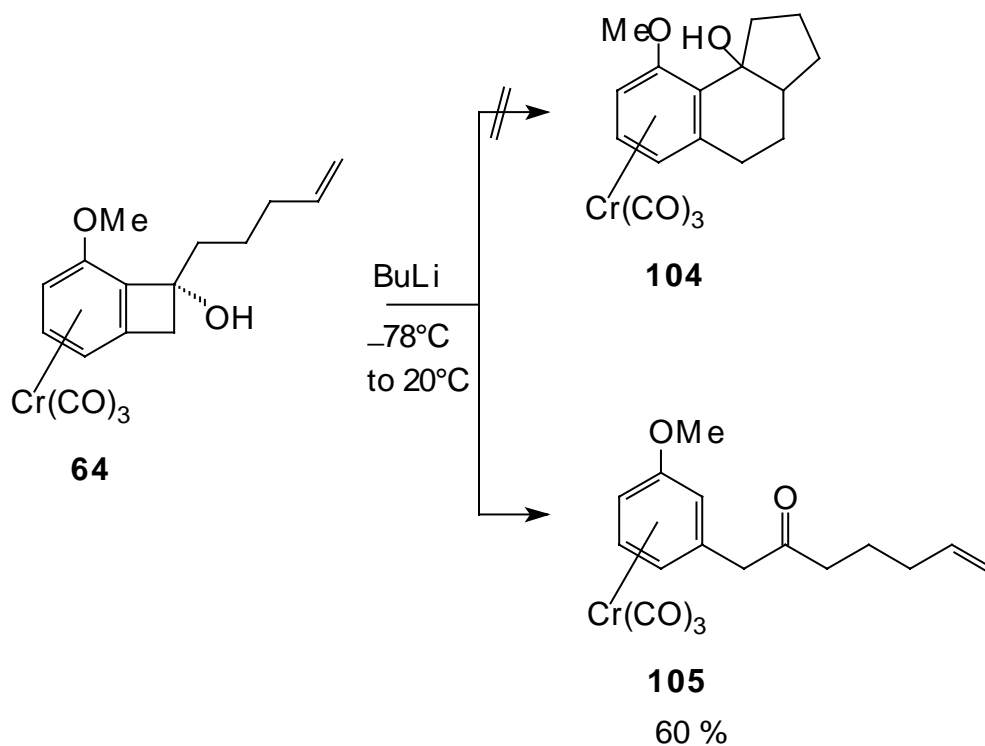

## 5.5 Hetero-Diel's Alder Cycloaddition

As described in chapter 5.2, the 1-*endo*-hydroxyl-6-methoxybenzocyclobutenol complex **58** can be used for the [4+2] cycloaddition reactions. Therefore it was thought that the complex **58** used for the hetero Diels Alder cycloaddition reactions, which are important since most of the alkaloids contain nitrogen as a principle atom.<sup>82</sup>

The benzocyclobutenol complex **58** was treated with 1.1 equivalent of methyl lithium at  $-78^{\circ}\text{C}$  in THF, the color changed from yellow to the orange yellow showing the deprotonation of alcohol. Four equivalents of acetonitril were added to the reaction mixture, a cycloadduct **106** was obtained in 68% yield after hydrolysis with 1M HCl.

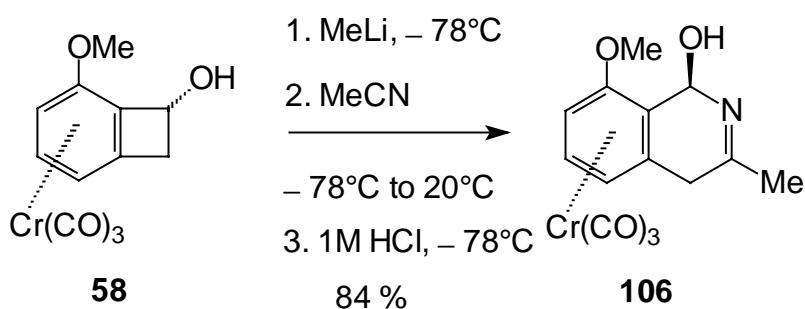

The complex **106** was identified by its spectral data. Olefson et al.<sup>87</sup> have performed several cyclization reaction of uncoordinated benzocyclobutenol with various nitriles for the synthesis of the Hypecumarine and 3-substituted Isoquinlines. However the mechanism he described was cyclization not a [4+2] cycloaddition. In his reaction if the product was treated with acid water molecule lost generating the aromatic ring.



## 6 Nucleophilic Addition at Benzocyclobutenedione Complex **42** and Dianionic Oxy-Cope Rearrangement

### 6.1 Background

Oxy-Cope rearrangements have immersed in recent years as highly useful sigmatropic reactions in organic synthesis.<sup>88</sup> The first oxy-Cope rearrangement was found in 1964 from the rearrangement of 1,5-hexadiene alkoxide. After that, a lot of new methods have been developed in this field. However, the first anionic oxy-Cope rearrangement was found with compound **107**.<sup>89</sup> When a compound **107** was heated with KH at 66°C, the rearrangement product **110** was obtained within 1 min in 98% yield. In this reaction first deprotonation took place forming an alkoxide **108**, which underwent the rearrangement giving the enolate **109** and finally the rearranged product **110**.

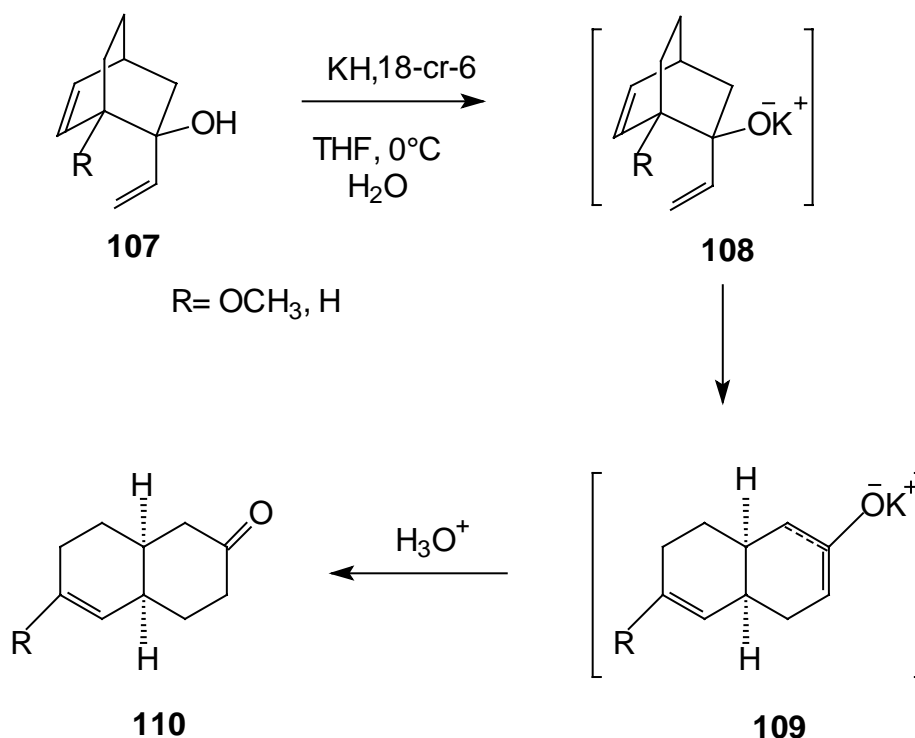

A lot of work was done to find the role of the metal in the anionic oxy-Cope rearrangement<sup>90</sup> and it was found that alkali metals, especially lithium, increased the rate of such reactions.<sup>91</sup>

In 1984, Bartmess et al.<sup>92</sup> found that a structural effect plays an important role for the increase of the rate of such an anionic Cope rearrangements. The nature of the substituent could determine the orbital orientation in the mechanism of the sigmatropic rearrangement reaction that has an effect on the rate of the anionic oxy-Cope [3,3] sigmatropic rearrangement.<sup>93</sup>

Paquette et al.<sup>94</sup> found that when two equivalents of 1-cyclopentenyllithium were added to the diisopropyl squarate (**111**), 1,2-double addition took place to give either *cis*- or *trans*-direction giving intermediates **112** and **113**.

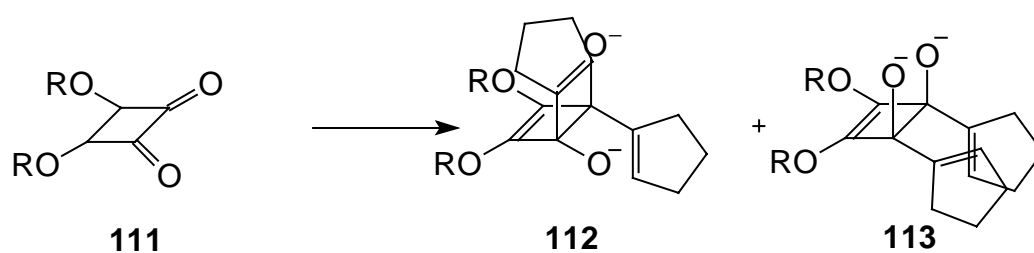

The *cis* intermediate **113** can adopt either a chair or a boat alignment of the cyclopentene double bond.

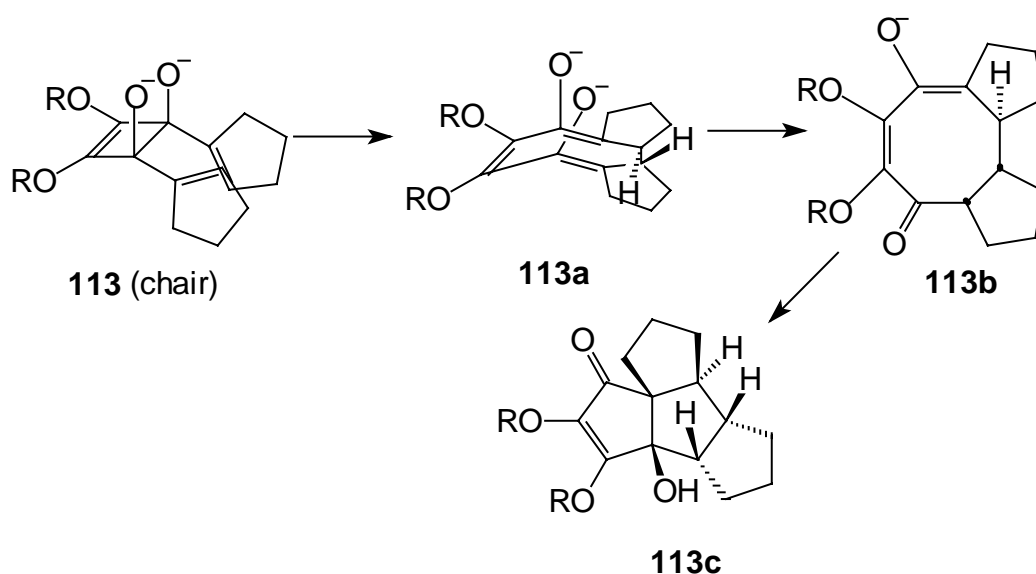



However, in the addition 2-propenyllithium to the benzocyclobutenedione complex **37**, the reaction did not stop at the dianionic oxy-Cope rearrangement products **118** and **119** but upon partial hydrolysis an intramolecular aldol addition followed to form a tricyclic product **117** as only one diastereomere as the main product.<sup>95, 96</sup>

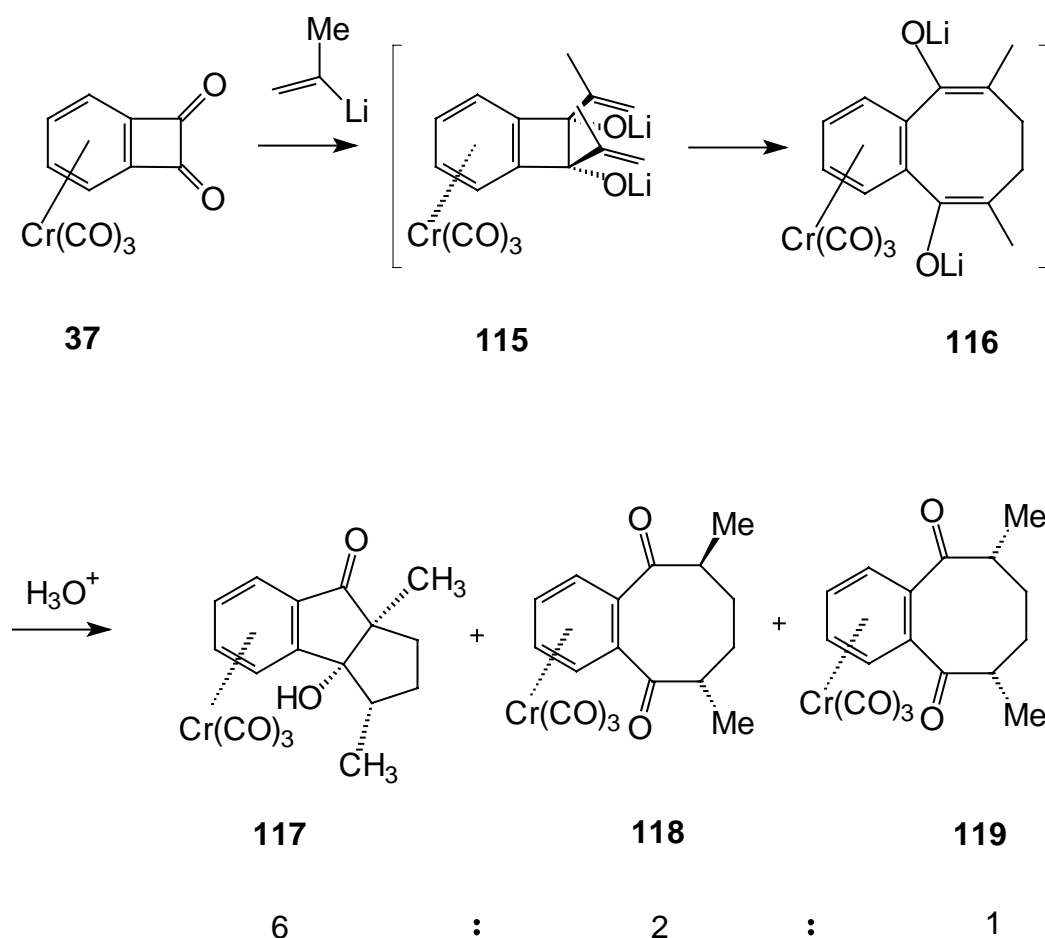

## 6.2 Dianionic Oxy-Cope Rearrangement followed by Intramolecular Aldol Addition

When the alkenyllithiums were added to the unsubstituted benzocyclobutenedione complex **37**, it underwent a dianionic oxy-Cope rearrangement at low temperature ( $-78^\circ\text{C}$ ). In this complex **37** the two carbonyl groups are not differentiated.

However, if a methoxy group is introduced at the aromatic ring of the benzocyclobutenedione **37**, it is interesting to know the effect of this substituent in the dianionic oxy-Cope rearrangement. After the introduction of the methoxy group at C-3 in the benzocyclobutenedione complex **42**, the electronic density as well as the symmetry of the complex **42** are changed. In fig 6, it is shown that the benzocyclobutenedione ligand contains two planes of symmetry ( $\sigma_v$  and  $\sigma_v'$ ). When it is complexed with chromium carbonyl, one plane of symmetry was eliminated giving the achiral complex **37**. In the complex **37**, the two carbonyl groups (C-1 and C-2) are enantiotopic due to the presence of the plane of symmetry ( $\sigma_v$ ).

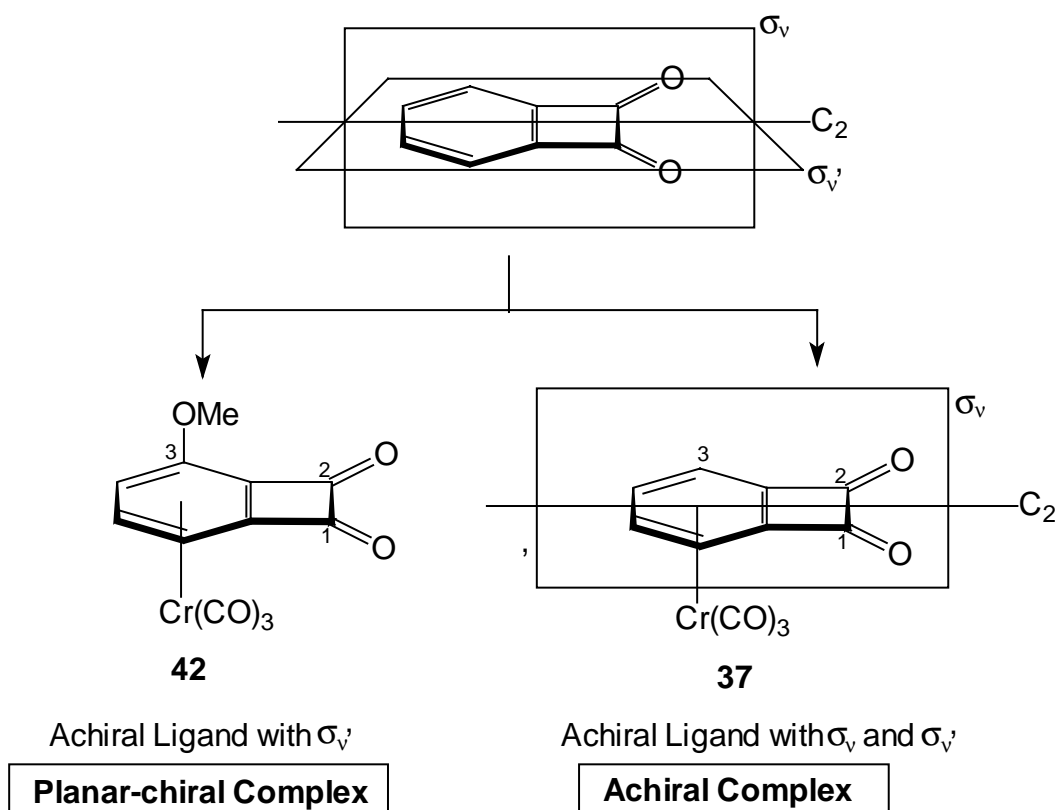
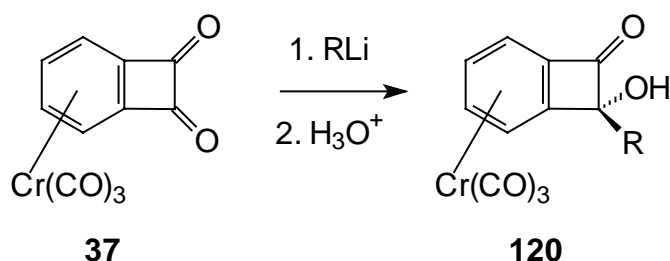
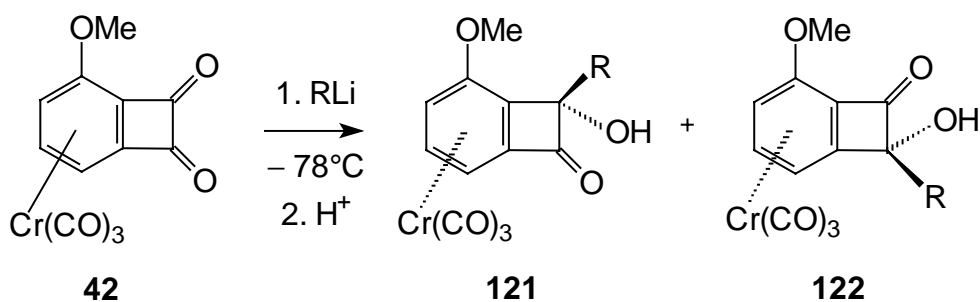

Fig 6: Loss of symmetry in the benzocyclobutenedione **42** after introduction of methoxy substituent at C-3 at **37**.

However, after the introduction of the methoxy group at C-3 in **37**, the symmetry is eliminated giving the planar chiral complex **42**. In the planar chiral complex **42**, the two carbonyl groups (C-1 and C-2) are not equivalent. Therefore it is obvious that there are more possibilities of products in the nucleophilic addition to complex **42** than in the achiral complex **37**. In the case of complex **37** due to the presence of the plane of symmetry, the two carbonyl groups are not distinguishable. When **37** is treated with one equivalent of nucleophile (**R**), addition takes place at either one of the two carbonyl groups resulting in the mono adduct **120**.



In contrast, the mono addition to the complex **42** could give two different products **121** and **122**.



The introduction of the methoxy group will not only affect the symmetry of complex **42** but also the electron density of the two carbonyl groups in **42**. After introduction of the methoxy group (an electron donating group) at C-3 in complex **42**, the reactivity of two carbonyl groups (C-1 and C-2) should be different. Thus it is interesting to explore the chemistry of **42** after the

introduction of electron donating methoxy group at C-3, especially in mono nucleophilic addition and dianionic oxy-Cope rearrangement. These aspects are so far new and no chemistry has been explored in this context.

### 6.2.1 Nucleophilic Addition with Lithium Aluminum Hydride

As explained in the previous chapter 3.1, lithium aluminium hydride easily reduces 6-methoxybenzocyclobutenone complex **43** at very low temperature ( $-78^{\circ}\text{C}$ ) diastereoselectively. Therefore this was used for the reduction of the diketone **42** in order to compare the reactivity of its carbonyl groups. When the complex **42** was treated with one equivalent of lithium aluminum hydride the reduction took place forming two products **123** and **124**.

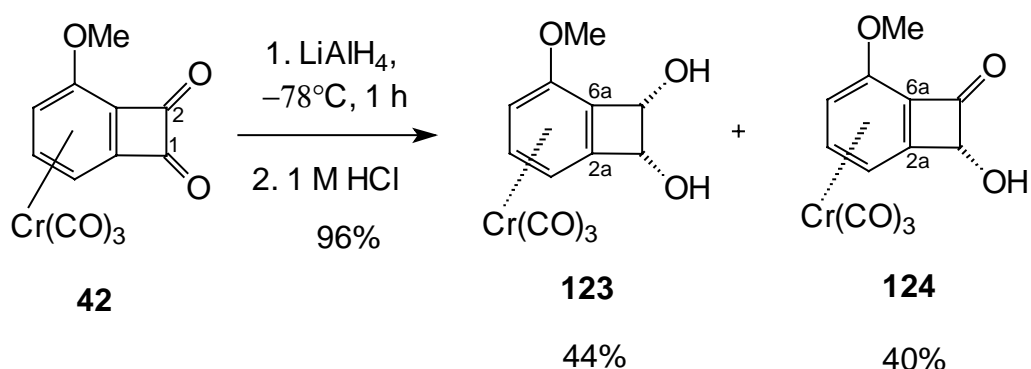

**123** was identified by comparing its spectroscopic data with the similar product from the unsubstituted complex.<sup>96</sup> However, **124** was confirmed from the comparison of its spectra with **123**. The MS spectrum showed 2 protons less than the **123**. The IR spectra of the complex **124** showed strong bands at  $1765 \text{ cm}^{-1}$  and  $3409 \text{ cm}^{-1}$  indicating the presence of a four-membered ring ketone and OH group. In the  $^{13}\text{C}$  NMR spectra, a signal for the atom C-6a appeared at  $\delta = 109.2$  and C-2a at  $\delta = 122.2$  in product **124** while the signal for C-6a appeared at  $\delta = 92.3$  and C-2a at  $\delta = 125.8$  in the product **123**. These  $^{13}\text{C}$  NMR showed that the value for C-6a shifted to higher field than the value of the same carbon atom in **123** indicating that C-6a in **124** is located next to the electron withdrawing

carbonyl group like carbonyl. The values of C-2a in **124** and in **123** were found to be similar ( $\delta=94.4$ ), also was found similar to the corresponding carbon atom of the known mono vinyl addition complex **126**.<sup>99</sup> All this indicates that **124** contains a carbonyl group next to the methoxy group as in complex **124**. However, the relative configuration of the hydroxyl group could not be confirmed from the spectral data analysis. It was assumed that hydride attacked from the face opposite to the chromium resulting *endo* product, as was the case in all known examples.<sup>105</sup> The formation of mono ketone complex **124** indicated that two carbonyl groups in complex **42** were different in terms of their reactivity. The carbonyl group, which is away from the methoxy substituent, is reduced faster than the carbonyl group next to methoxy group resulting in **124**. This can be explained by taking into account the resonance formulas **42a** and **42b**.

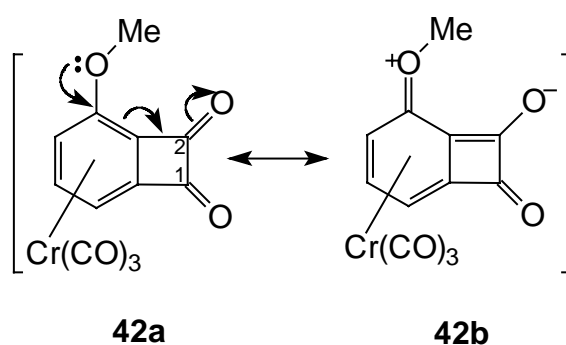

Inspection of resonance formulas **42a** and **42b** teaches that the electron density should be increased at C-2 preferentially. This causes C-1 to be the more electrophilic carbonyl carbon atom, resulting in the complex **124**.

### 6.2.2 Selective Hydrolysis of Bisacetal Complex **57**

The differences in the reactivity of the two carbonyl groups were also shown in the hydrolysis of bis-acetal complex **57**. When the methoxy substituted bisacetal complex **57** was hydrolyzed with 50% HCl, a mixture of **125** and **42** was obtained. After a column chromatographic separation, an orange complex mono acetal **125**



in 35% yield and the deep-red 6-methoxybenzocyclobutendione complex **42** in 46% were obtained.

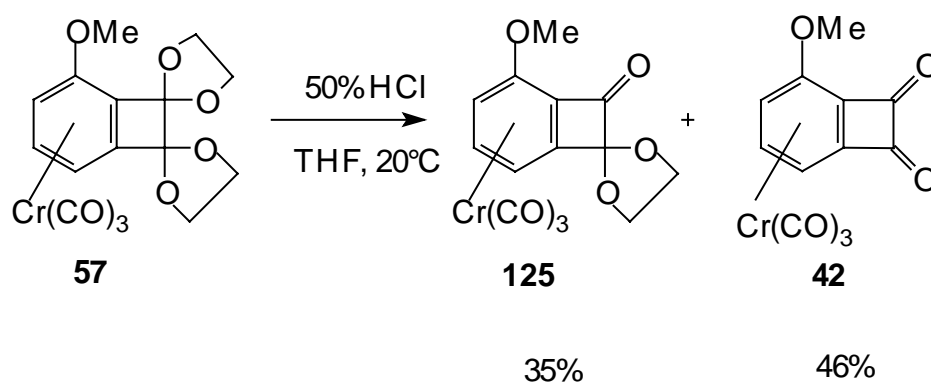

The complex **125** was identified by analysis of the spectroscopic data. In the  $^1\text{H}$  NMR, a multiplet at  $\delta = 4.28$  with four protons after integration indicates the presence of one acetal group at complex **125**, in contrast to the bisacetal complex **57** with two multiplet at  $\delta = 4.28$  and  $\delta = 4.17$  and 8 protons after integration. However, the analysis of spectral data did not say which carbon atom either, C-1 or C-2, bears the acetal group in the complex **125**.

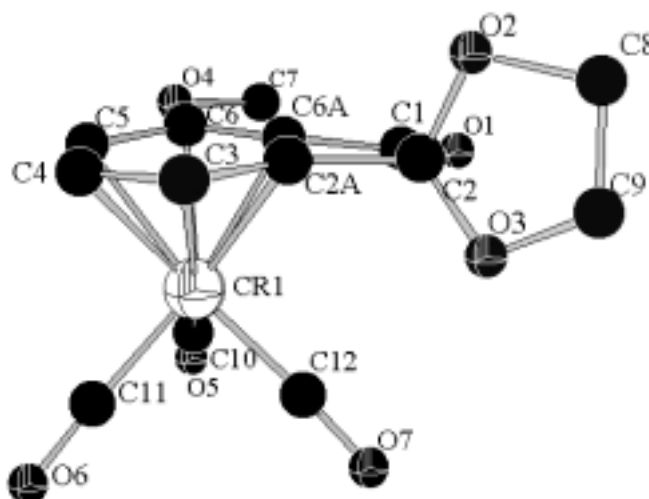

Fig 7: Structure of monoacetal complex **125** in the crystal.

The configuration could finally be confirmed by a crystal structure analysis of **125** (fig.7). The carbonyl group lies near to the methoxy group, C-1 hydrolyzed while C-2 bears the acetal group. This indicated that the electron density in C-1 was higher as compared to the C-2 in the 6-methoxybenzocyclobutendione complex **42**.

<b>Bond length in Å</b>			
		C1 - C2	1.581(7)
Cr - C2a	2.167(5)	C1 - C2a	1.501(8)
Cr - C3	2.222(5)	C2 - C2a	1.517(7)
Cr - C4	2.179(5)	C2a - C3	1.387(7)
Cr - C5	2.220(5)	C2a - C6a	1.429(7)
Cr - C6	2.273(5)	C3 - C4	1.396(8)
Cr - C6a	2.185(5)	C4 - C5	1.388(8)
Cr - C10	1.796(5)	C5 - C6	1.406(8)
Cr - C11	1.825(6)	C6 - C6a	1.401(9)
Cr - C12	1.835(6)	C8 - C9	1.490(8)

<b>Bond angle in °</b>			
C1 - C2 - C2a	85.9(4)	C1 - C6a - C2a	92.3(4)
C2 - C2a - C1	93.1(4)	C2 - C1 - C6a	87.9(4)

<b>Torsion Angle in °</b>			
C6a - C2a - C2 - C1	- 6.8(4)	C2a - C2 - C1 - C6a	6.5(4)
C2a - C6a - C1 - C2	- 6.8(4)	C1 - C6a - C2a - C2	7.1(4)

The methoxy group is bent towards the four-membered ring. The angles in the four member ring do not show much difference [C1 - C2 - C2a = 85.9(4), C1 - C6a - C2a = 92.3(4), C2 - C2a - C1 = 93.1(4), C2 - C1 - C6a = 87.9(4)]. However, the four membered ring is not co-planar with the benzene ring. The torsion angle C3 - C2a - C6a - C6 = 171.3(5)°; C2 - C2a - C6a - C6 = - 177.3(5)°. This

indicates that the one side of cyclobutene bearing acetal is planer while the next side of cyclobutene bearing ketone group is bent by 8° from the plane of aromatic ring. This might be the effect of the electron withdrawing effect of the chromium carbonyl and the carbonyl group. The carbonyl group of chromium does not lie directly below the four membered ring but away from the four membered ring as seen in fig 8.

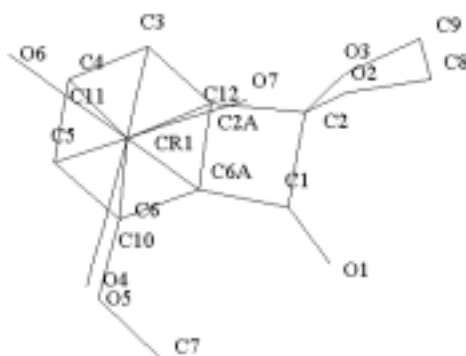

Fig 8: The view of crystal structure of **125** keeping chromium carbonyl in front.

Thus, the above two examples of mono addition and mono acetal formation from the 6-methoxybenzocyclobutenedione complex **42** indicated that the carbonyl group far from the methoxy group (C-2), has more electron density as compared to the carbonyl group near to methoxy group (C-1). Thus, the C-1 carbonyl group is more reactive towards the nucleophilic addition in 3-methoxybenzocyclobutenedione complex **42**.

### 6.2.3 Treatment of the 3-Methoxybenzocyclobutenedione Complex **42** with One Equivalent of Vinyl lithium

As described in chapter 6.2.2, the two carbonyl groups of 3-methoxybenzocyclobutenedione complex **42** are different in terms of the reactivity for nucleophilic addition. By taking this advantage of the reactivity difference, 1.0 equivalent of the vinyl magnesium bromide was added to the 3-

methoxybenzocyclobutenedione complex **42** at  $-78^{\circ}\text{C}$ . After hydrolysis, the mixture of **126**<sup>99</sup> and **127** (3:1) was obtained as an orange solid in 80% yield.

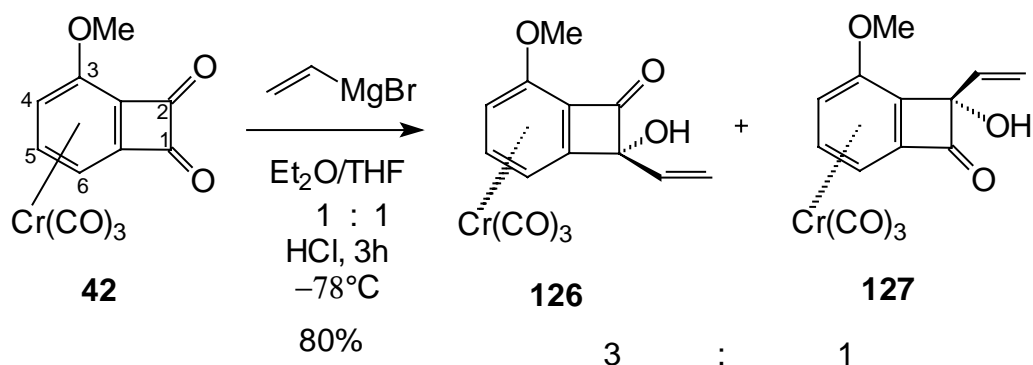

In the  $^1\text{H}$  NMR-spectra, two clear methoxy signals were found at  $\delta = 3.95$  and  $\delta = 4.03$ . Like that the two clear triplet signals for 5-H were found at  $\delta = 5.94$  and  $\delta = 6.08$  with the same coupling constant. From the integration of the signals (both  $\text{OCH}_3$  and 5-H), the ratio of the two complexes was found to be 3:1. In the  $^{13}\text{C}$  NMR-spectra, there are clearly two signals for the ketone at  $\delta = 188.7$  and  $\delta = 185.0$ . Similarly, there are two signals for the chromium carbonyl groups at  $\delta = 231.2$  and at  $\delta = 230.7$ , two clear signals for methoxy, and two sets of signals for the aromatic carbon atoms. All these data clearly show the presence of two complexes **126** and **127**. However, if the spectrum of the known complex **126**<sup>99</sup> is compared with the spectrum of mixture, the extra signals in the  $^1\text{H}$  NMR spectrum,  $\delta = 3.95$  for  $\text{OCH}_3$ ,  $\delta = 5.94$  for 5-H and in  $^{13}\text{C}$  NMR,  $\delta = 188.7$  for ketone,  $\delta = 231.2$  for chromium carbonyl group indicate a presence of **127**. Later, the major product **126** was obtained as a pure complex by column chromatography and identified by comparing its spectral data with the spectral data of the compound **126** from which the X-ray was obtained.<sup>99</sup> This shows that compared to the C-2 carbonyl group the C-1 was found more reactive to the nucleophilic addition. This can be explained by the electron donating effect of methoxy group at C-3.

The vinyl group attacked exclusively from the face opposite to the chromium carbonyl group resulting the *endo* alcohols, **126** and **127**. This is an important

result to explore the symmetry of **42** for selective dianionic oxy-Cope rearrangement followed by the intramolecular aldol addition and similar reactions.<sup>95-99</sup>

### 6.3 Nucleophile Addition to the complex **126**

The selective addition to one carbonyl of the 3-methoxybenzocyclobutenedione complex **42** opens a new field in the dianionic oxy-Cope rearrangement. Because two different nucleophiles can be added to explore the dianionic oxy-Cope rearrangement. Moreover the selective addition products **126** and **127** could be used to explore the selectivity in the intramolecular aldol addition reactions. Therefore, the complexes **126** and **127** were treated with different nucleophiles like vinyl lithium, 2-propenyl lithium, cyclopentenyl lithium etc.

#### 6.3.1 Addition of Vinyl lithium to **126**

In the unsubstituted complex **37**, addition of an alkenyl nucleophile to the ketone groups results in a dianionic oxy-Cope rearrangement at low temperature. Therefore 4 equivalents of vinyl lithium was added to the mono vinyl complex **126** at low temperature to explore the dianionic oxy-Cope rearrangement and intramolecular aldol addition. After the hydrolysis, an orange solid **128** was obtained in 72% yield as only one diastereomer.

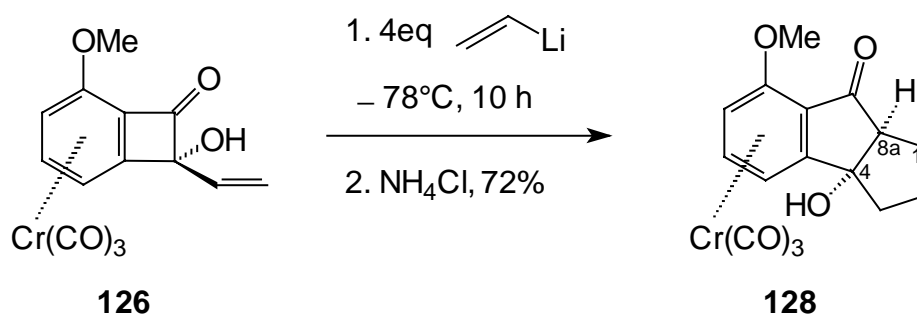

The **128** complex was identified by comparing the spectral data with those of corresponding product from unsubstituted complex.<sup>96</sup> In the IR spectra, a strong band at 1703 cm<sup>-1</sup> and a broad band at 3399 cm<sup>-1</sup> indicated the presence of one carbonyl and an alcohol group in the complex. In the <sup>1</sup>H NMR spectrum, a signal at  $\delta = 2.99$  with coupling constant  $J_{cis} = 7.16$  Hz and  $J_{trans} = 2.78$  Hz shows the evidence for 8a-H. These and other spectral data show that the product was not only the dianionic oxy-Cope rearrangement eight membered ring but that the rearrangement had been followed by an intramolecular aldol addition forming the tricyclic complex **128**. However, the relative configuration of C-8a and C-4 could not be determined from the spectra. Because of the presence of a bulky chromium group at one side of the complex **128**, it was assumed that the intramolecular aldol addition takes place from face opposite to the chromium resulting the *endo* OH and 8a-H as the complex **128**. This is in full accord with the corresponding configuration in the unsubstituted case.

In this reaction, there are two possible intramolecular aldol additions after the first protonation step. However, in the spectral data indicate only one product has been formed. This can be explained as follows:

When the complex **126** was treated with vinyl lithium at -78°C, the vinyl lithium added to the complex **126** from the face opposite to the bulky chromium carbonyl moiety resulting in the *syn* or *cis* addition to complex **126**. The double vinyl *cis* addition favors the dianionic oxy-Cope rearrangement resulting in the benzocyclooctadienolate intermediate **129**. This intermediate could lead to two other intermediates **129a** and **129b** after single protonation. These two intermediates **129a** and **129b** can undergo an intramolecular aldol addition giving the products **128** and **130**, respectively. However, the above reaction only the product **128** was obtained in good yield. This indicates selective formation of the intermediate **129a** at the protonation step so that an intramolecular aldol addition gives the product **128**. That formation of intermediate **129a** is favored over the intermediate **129b** could be the effect of the methoxy group present in the intermediate **129**. This methoxy group can effect in two ways either by pushing

electron density to enolate-1 or by more likely, chelation with lithium counter ion of enolate-1 in **129**.

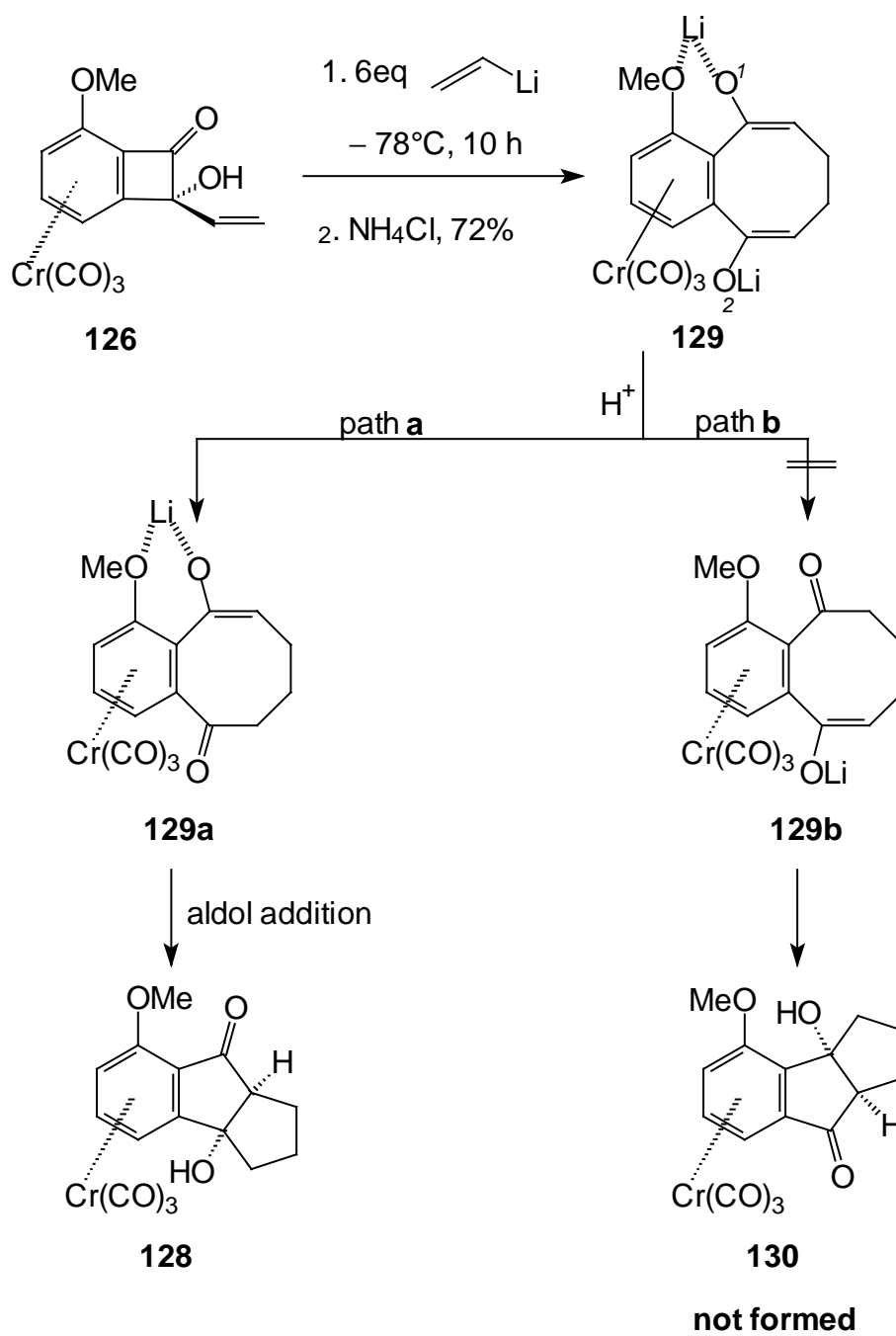

Thus the methoxy group favors the formation of intermediate **129a** rather than the formation of intermediate **129b**. Such a stereocontrol initiated product was also observed in the addition of lithiated methoxy cyclopentene and 1-methyl vinyl to squarate **131**.<sup>100</sup> The intermediate **132** was first formed, which after  $\beta$ -elimination of methoxide gave intermediate **133**. Because of the chelating effect as shown in **133**, the aldol addition favored only to form the compound **134** in 64% yield.

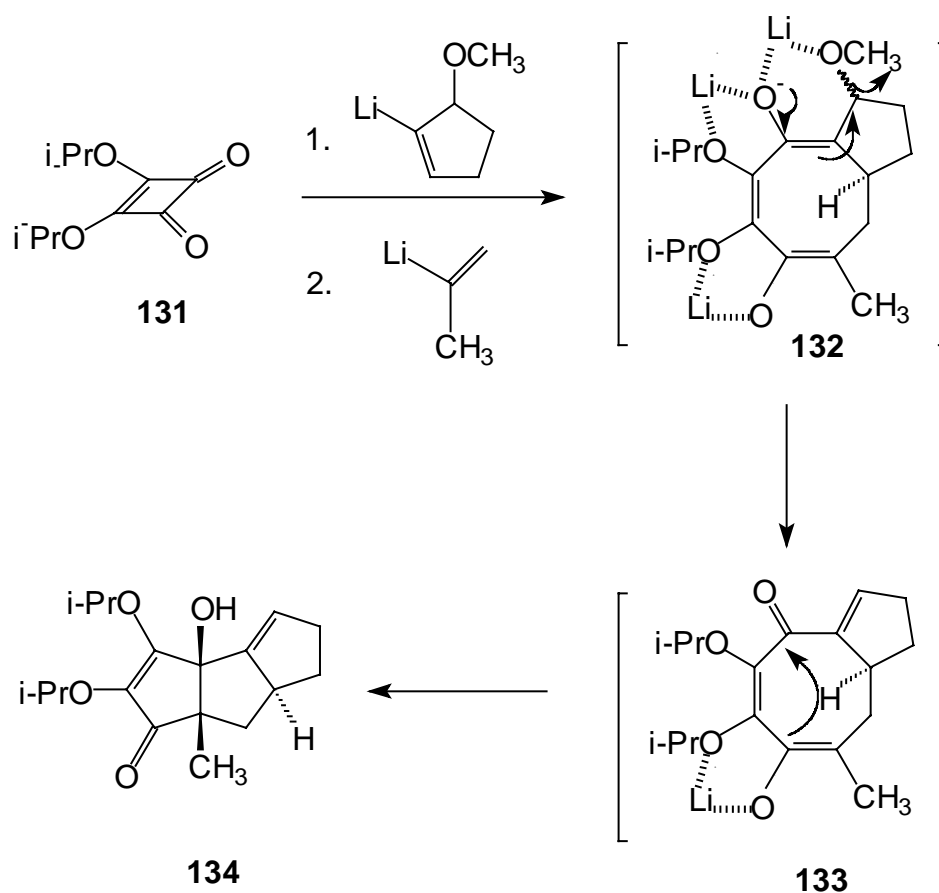

### 6.3.2 Nucleophilic Addition of 1-Cyclopentenyllithium to the Complex **126**

The addition of vinyl lithium to the complex **126** shows the high selectivity at the intramolecular aldol addition in the dianionic oxy-Cope rearrangement product. Therefore, to explore the selectivity of the intramolecular aldol addition 1-cyclopentenyllithium was used as a cyclic alkenyllithium. 1-cyclopentenyllithium



was prepared by treating 1-bromocyclopentene with lithium sand.<sup>110</sup> 4 equivalents of the 1-cyclopentenyllithium was added at low temperature to the mono vinyl adduct complex **126**, an orange solid **135** was obtained in 62 % yield after hydrolysis. As in the previous reactions, another expected product **136**, was not observed.

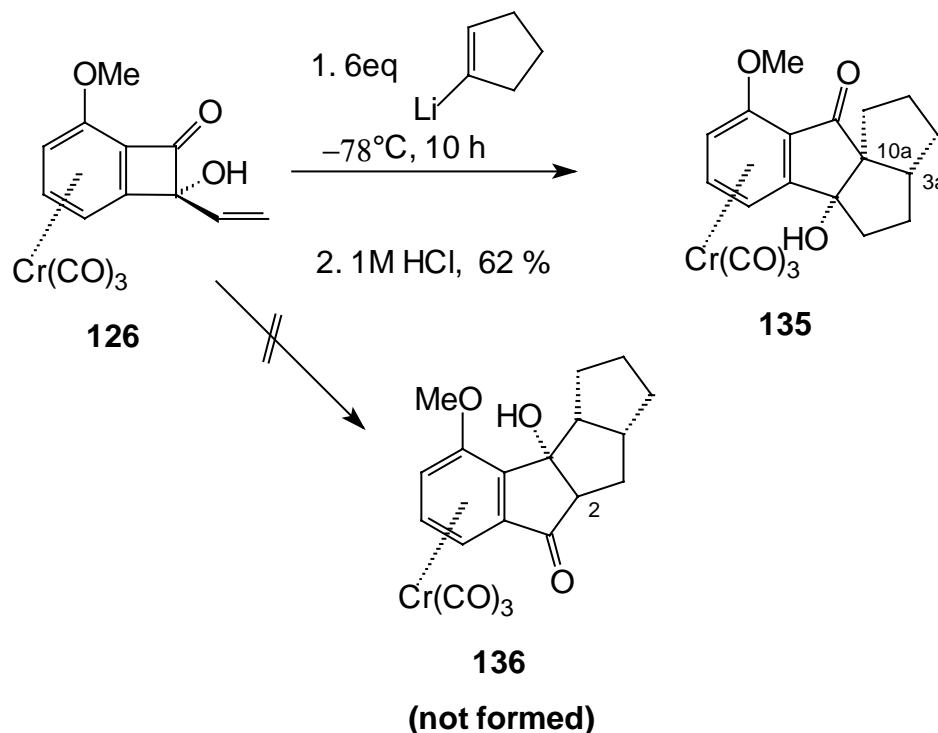

The compound **135** was identified by its spectral data. However, the relative configuration at C-3a, C-10a and OH could not be confirmed from the spectral data analysis. In the all comparable cases,<sup>105</sup> it was assumed that the intramolecular aldol addition takes place from the face opposite to chromium so that the configuration in C-3a, C-10a and OH should be bent toward the side of chromium. After getting a crystal structure of the complex **135** (fig.9), the relative configuration of the molecules **135** at C-3a, C10a and OH was confirmed. From this crystal structure it was confirmed that intramolecular addition takes place from the face opposite to the chromium.

In fig. 9, the cyclopentane ring and the hydroxyl group are in *cis* and bent toward the face of the chromium. In contrast to the structure of the mono ketone, diketone

complex and mono acetal complex, one of the chromium carbonyl groups was found to lie just below the five membered ring.

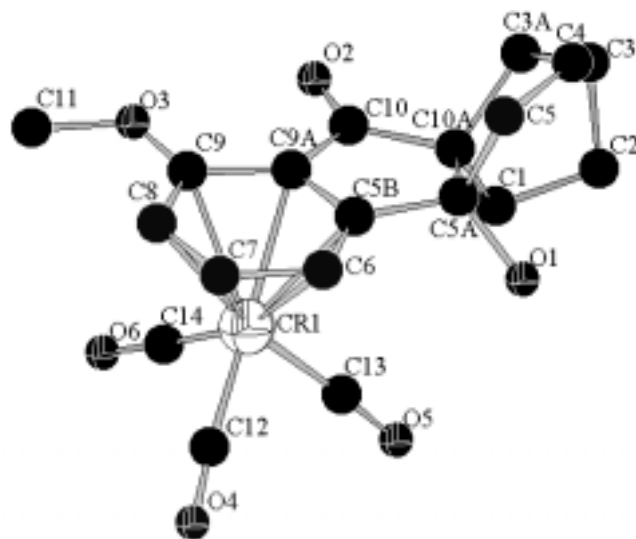

Fig. 9: Crystal structure of **135** in the crystal

Bond length in Å			
Cr - C14	1.75(2)	C1 - C2	1.539(12)
Cr - C12	1.815(13)	C1 - C10a	1.539(12)
Cr - C13	1.846(11)	C2 - C3	1.465(12)
Cr - C7	2.146(11)	C3 - C3a	1.535(14)
Cr - C5b	2.193(10)	C3a - C4	1.453(2)
Cr - C8	2.204(10)	C3a - C10a	1.576(11)
Cr - C6	2.235(11)	C4 - C5	1.501(2)
Cr - C9a	2.242(8)	C5 - C5a	1.572(13)
Cr - C9	2.276(11)	C5a - C10a	1.509(14)
C5a - C5b	1.510(13)	C5b - C9a	1.376(13)
C5b - C6	1.415(13)	C6 - C7	1.406(13)
C7 - C8	1.382(2)	C8 - C9	1.429(14)
C9 - C9a	1.421(13)	C9a - C10	1.478(14)
C10 - C10a	1.509(14)		

The five-membered ring (**B**) is bent away from the chromium side i.e. up from the plane of the benzene ring with  $111.7(8)^\circ$  [C10-C10a-C3a] and  $110.4(8)^\circ$  [C5b-C5a-C5]. The hydroxyl group is bent towards the same side of the cyclopentane ring (**C**) i.e. towards the chromium moiety. The methoxy group was bent away from the ketone of cyclopentenone ring (**A**), while in the case of 6-methoxy-2-ethylendioxy-benzocyclobutenone complex **125** the methoxy group was bent towards the four-membered ring.

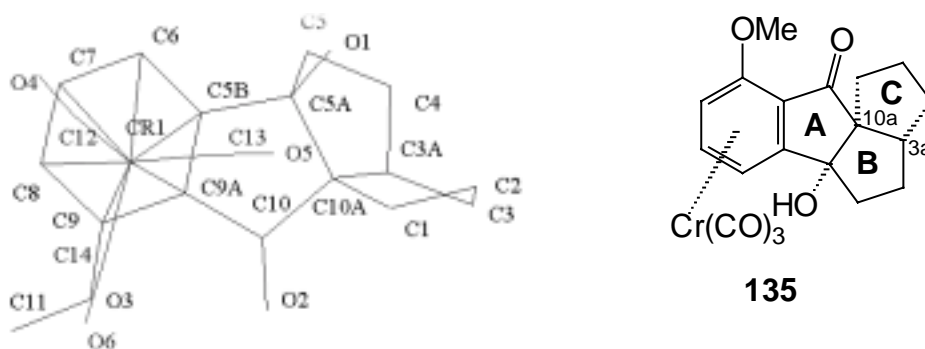
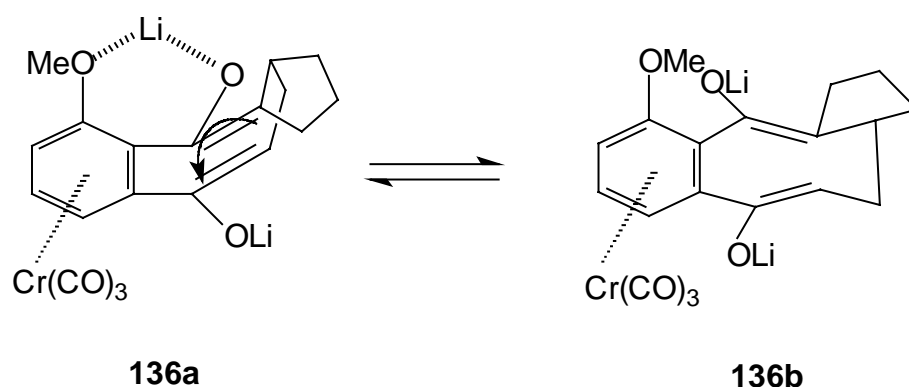

Fig. 10: View of the crystal structure from the topside.

From the study of the crystal structure, the information concerning the stereochemical course of the reaction is available from the relative configurations of the product **135**. Most probably, the additions of 1-cyclopentenyllithium takes place from face opposite to the chromium fragment resulting a *cis*-dialkenyl (vinyl and cyclopentyl) intermediate, which undergoes a double anionic oxy-Cope rearrangement. The intermediate benzocyclooctanediolate **136** can be formed in two conformations, a boat conformation **136a**, and a flatter, twisted conformation **136b**. However for the intramolecular aldol addition, the conformation **136a** is more favorable than the conformation **136b**. This conformation leads the product **135** as the bulky cyclopentane ring (**B**) up from the plane of aromatic ring and the next cyclopentane ring (**C**) and the hydroxyl group goes down as shown in fig 9.



In the above reaction, an unexpected product **137** in 20 % was also observed together with product **135**. These two compounds were separated by column chromatography and the ratio of these two products was found in 3:1. The formation of complex **137** can be explained as follows.

As explained in chapter 6.2.3 the mono addition of vinylmagnesiumbromide gave two mono adducts **126** and **127** in 3:1 ratio, which were not separable. Therefore when 1-cyclopentenyllithium was added to the mono adduct mixture (see chapter 6.2.3), a dianionic oxy-Cope rearrangement followed by intramolecular aldol addition product **137** was obtained from the addition of 1-cyclopentenyllithium to mono vinyl complex **127**.

In this reaction it was thought that the compound was the next possible intramolecular product **136**. However there was no matching signal in both  $^1\text{H}$  NMR and  $^{13}\text{C}$  NMR for the carbon C-2 as in the complex **136**. All spectral data analysis did not match for the **136** but it was exactly matching for the complex **137**. This was confirmed later after getting the crystal structure (fig. 9).

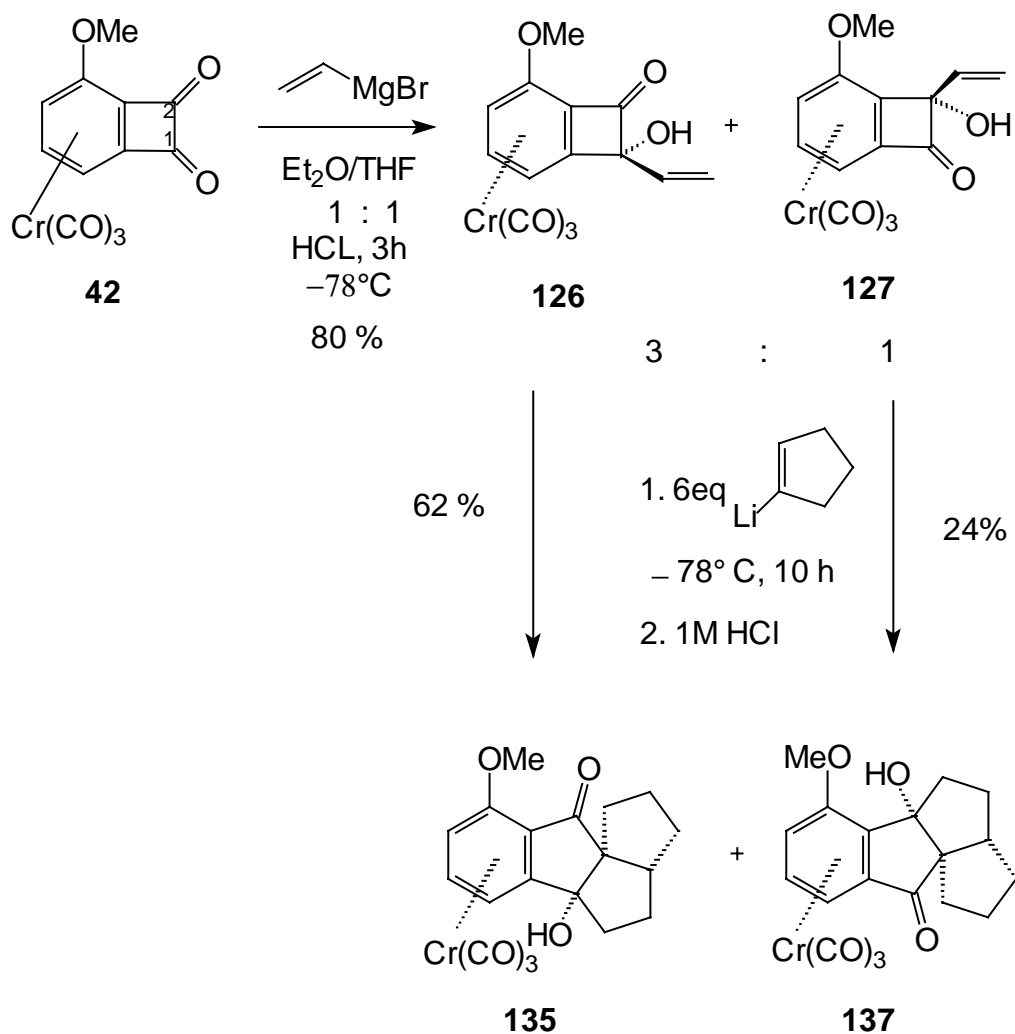

The reaction mechanism could be explained as followed:

When 1-cyclopentenyllithium was added to complex **127** the dienolate intermediate **138** is formed. This intermediate **138** leads to two possible intermediates **138a** and **138b** at the first protonation step. In most previous examples, the intermediate similar to the **138a** was more favorable than **138b** at protonation and the intramolecular aldol addition followed by path **a**. However, in this reaction, complex **137** was obtained by intramolecular aldol addition, which indicates that the intermediate **138b** is favored over the intermediate **138a** at the protonation step. This could be explained by taking the steric bulk of the cyclopentane ring into account. In the intermediate **138a**, the protonation is less favored at C-4 as compared to the protonation C-1 due to the bulky cyclopentane

ring. Therefore it is obvious that the protonation takes place by path **b** resulting in the intermediate **138b** and then the intramolecular aldol addition gave the complex **137**.

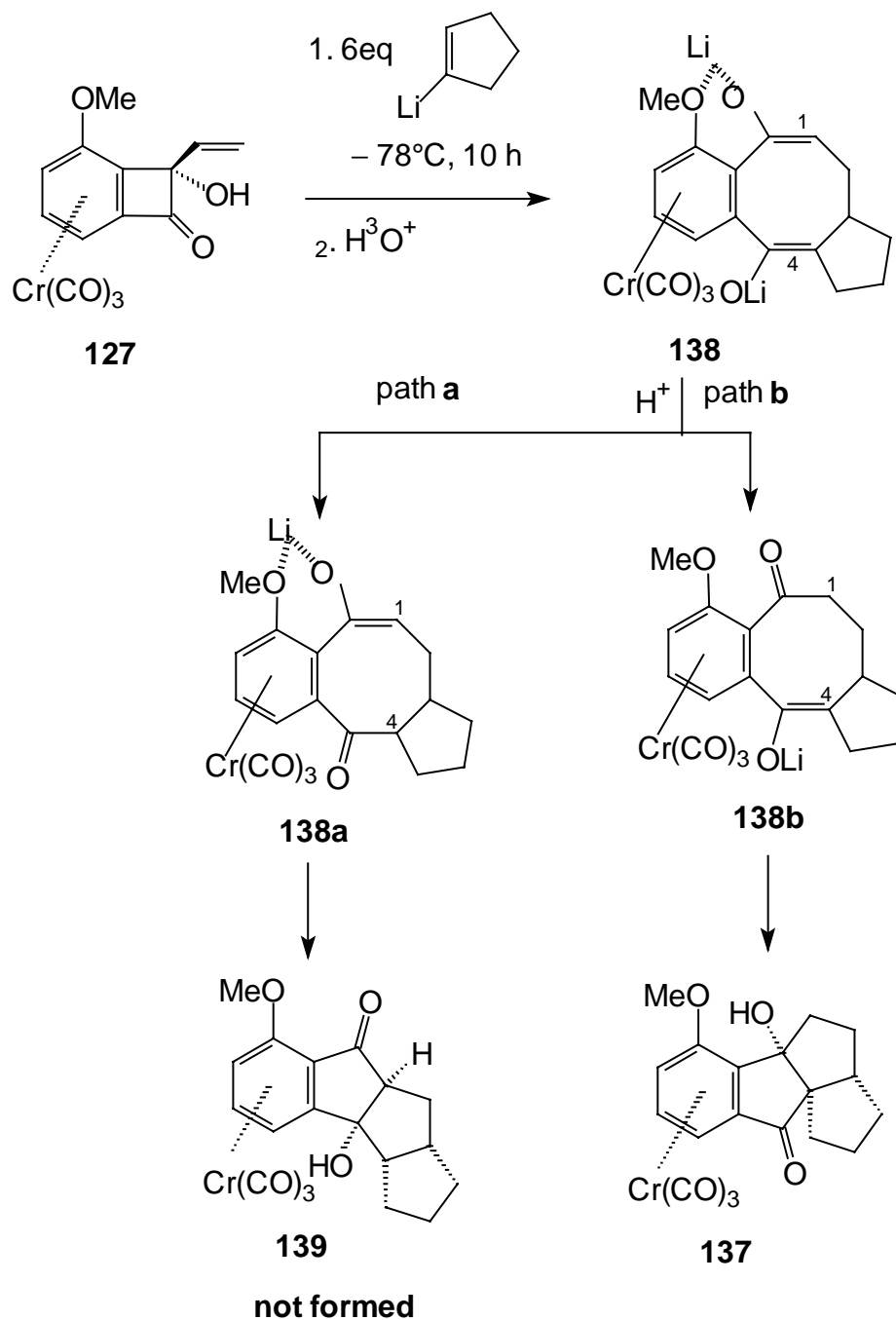

This unexpected product indicates that the steric factor dominates over the chelation factor in this dianionic oxy-Cope rearrangement followed by

intramolecular aldol addition. The relative configuration of the product **137** was confirmed by the crystal structure (fig. 11).

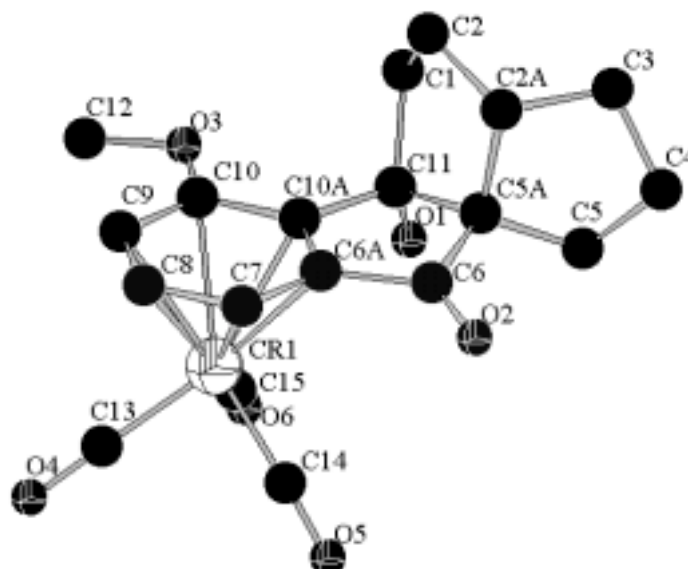

Fig.11: Crystal structure from complex **137**

Bond length in Å			
Cr - C6a	2.201(4)	C6 – C6a	1.496(6)
Cr - C7	2.200(4)	C6a - C7	1.415(6)
Cr - C8	2.178(4)	C6a - C10a	1.399(6)
Cr - C9	2.222(4)	C7 – C8	1.380(6)
Cr - C10	2.287(4)	C8 – C9	1.396(6)
Cr - C10a	2.249(3)	C9 – C10	1.408(6)
Cr - C13	1.832(4)	C10 - C10a	1.408(6)
Cr - C14	1.830(4)	C10a - C11	1.527(5)
Cr - C15	1.843(4)	C1 – C2	1.492(6)
C2 - C2a	1.510(6)	C2a - C3	1.511(5)
C2a - C5a	1.592(4)	C3 – C4	1.486(6)
C4 - C5	1.536(6)	C5 – C5a	1.525(5)
C5a - C6	1.511(6)	C5a- C11	1.556(5)

The crystal structure of **137** shows a similar relative configuration as the crystal structure of **135**. The difference is only the cyclopentane ring **C** in **135** lies at same side to the methoxy group while in the complex **137**, this ring was found at the opposite side to the methoxy group. The hydroxyl group and cyclopentane ring are *cis* and bent towards the same face to the chromium. The methoxy group bends away from the cyclopentanone ring. There are not many differences in bond lengths in the complex **137** and **135**.

Such intramolecular aldol reaction including transannular cyclization due to the steric effect recently have been reviewed by Heathcock.<sup>101</sup> Paquette has used such steric factor for the regioselective reactions from a squarate.<sup>102</sup> Such steric effect was applied in selective synthesis of important organic compounds.<sup>103</sup>

### **6.3.3 Nucleophilic Addition of Substituted Vinylolithium (2-propenyllithium) to Complex 126**

The dianionic oxy-Cope rearrangement and aldol addition with a simple vinyl nucleophile has shown high selectivity. It is interesting to know whether or not such selectivity will also be observed with substituted vinyl lithium. Like 2-propenyllithium. The 2-propenyllithium was prepared by refluxing the bromopropene with lithium sand.<sup>110</sup> The 2-propenyllithium contains a methyl group which might have some effect on the reaction selectivity. The 2-propenyllithium was added to the monovinyl benzocyclobutenone complex **126**, an orange solid **141** was obtained in 76% yield as the only product, and another possible product **142** was not observed.

This shows that the methyl substituent at the vinyl group does not have an effect on the selectivity of the dianionic oxy-Cope rearrangement and intramolecular aldol addition.



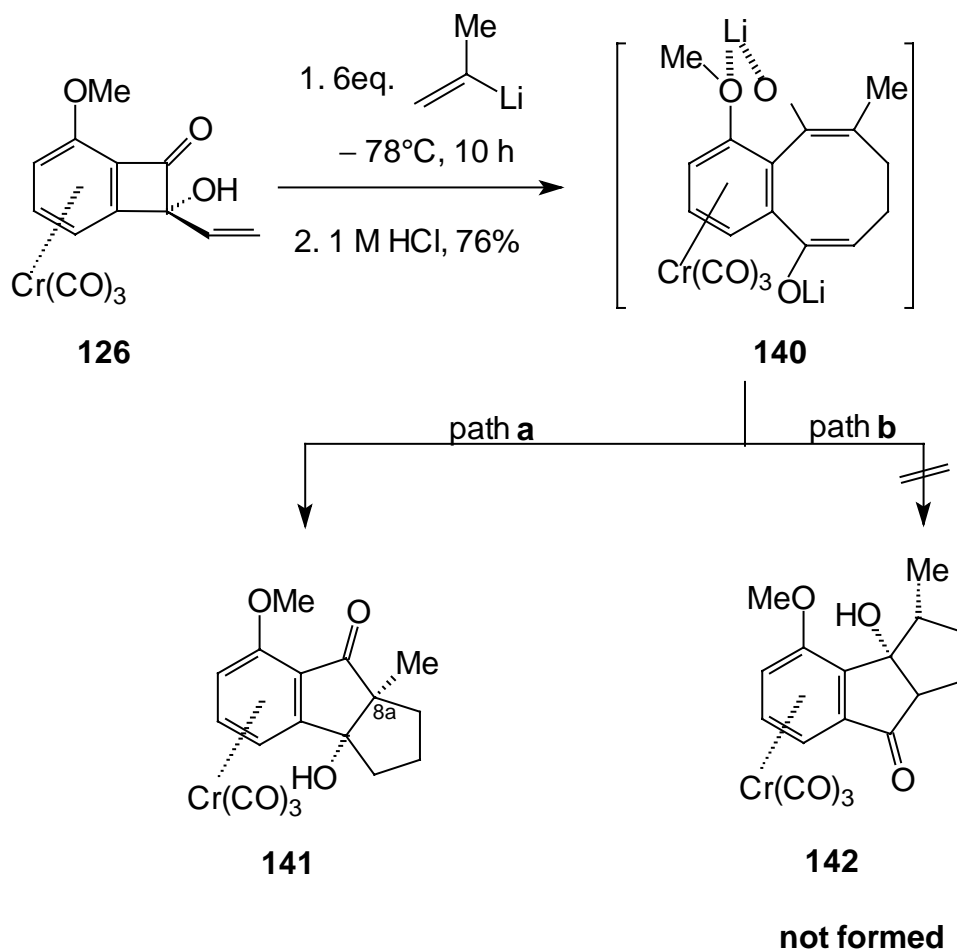

The complex **141** was characterized by comparing the spectroscopic data with the similar compound with two methyl groups from the unsubstituted complex.<sup>96</sup> In contrast,  $^1\text{H}$  NMR and  $^{13}\text{C}$  NMR analysis, there is no signal for the  $\text{CHCH}_3$  like in the compound from unsubstituted complex and only a singlet at  $\delta = 1.34$  in  $^1\text{H}$  NMR and quaternary signal (C-8a) at  $\delta = 38.99$  in  $^{13}\text{C}$  NMR correspond to the signal for the  $\text{CCH}_3$ . These and other spectral data gives the evidence for the product **141**. The relative configuration of methyl group at C-8a could not be identified from these spectral analysis. However it was assumed that the intramolecular aldol addition takes place from the face opposite to the chromium so that the OH and methyl group (C-8a) were cis and bent towards the side of chromium.

## 6.4 Double Nucleophilic Addition to the 3-Methoxybenzocyclobutenedione Complex **42**

In chapter 6.3 it was discussed that the stepwise nucleophilic addition of alkyllithium to 3-methoxybenzocyclobutenedione complex **42** using either the same or different nucleophiles shows high selectivity in the dianionic oxy-Cope rearrangement followed by an intramolecular aldol addition. However, it was not confirmed what was the cause of the selectivity, either to the methoxy group or the location of the second nucleophile. Therefore it was thought to use same nucleophile in a twofold addition to the 3-methoxybenzocyclobutenedione complex **42** in order to find the cause of the selectivity in the dianionic oxy-Cope rearrangement followed by intramolecular aldol addition. This reaction was already observed in the case of unsubstituted complex **37** when it was treated with an excess of nucleophile. However due to the symmetry of the dianionic oxy-Cope rearrangement product, selectivity could not be observed at intramolecular aldol addition in the unsubstituted complex. In contrast, due to elimination of symmetry, the two products resulting from the different paths of the intramolecular aldol addition could be differentiated in the methoxy substituted complex. Therefore to explore the selectivity in the dianionic oxy-Cope rearrangement followed by an intramolecular aldol addition, the 6-methoxybenzocyclobutenedione complex **42** was treated with an excess of different nucleophiles at low temperature ( $-78^{\circ}\text{C}$ ).

### 6.4.1 Addition of Vinylithium to the 6-Methoxybenzocyclobutenedione Complex **42**

The 6-methoxybenzocyclobutenedione complex **42** was treated with 8 equivalents of vinylithium at  $-78^{\circ}\text{C}$  in THF, and compound **128** was obtained in 76% as only one product after hydrolysis. Vinyl lithium added to both carbonyl groups of the 3-methoxybenzocyclobutenedione complex **42** exclusively from the face opposite to the chromium carbonyl moiety so that *cis* diaddition facilitated the dianionic oxy-Cope rearrangement resulting in the benzocyclooctenedienolate **129** (see

6.3.1). This intermediate **129** could be protonated in two ways forming product **128** via the intermediate **129a** and product **130** via the intermediate **129b** by intramolecular aldol addition. Although there are two possible aldol products **128** and **130**, only one product **128** was obtained in high yield.

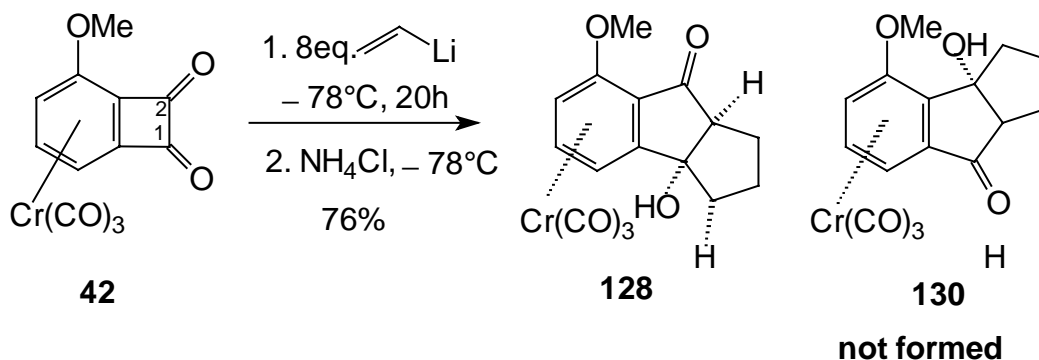

Comparing the spectra with the same compound obtained in chapter 6.3.1 identified the product **128**. The dianionic oxy-Cope rearrangement followed by intramolecular aldol additions are very important since such reactions are few known either with in complex or uncoordinated compounds and this reaction could be used to make complicated carbon skeleton and natural products<sup>106</sup> in few steps. In a recent publication from Butenschön *et al.*<sup>107</sup> have shown some dianionic oxy-Cope rearrangements and their intramolecular aldol addition with uncoordinated ketones with vinyl lithium under low temperature ( $-78^\circ\text{C}$ ).

#### 6.4.1 Double Addition of 2-Propenyllithium to 3-Methoxybenzocyclobutenedione Complex **42**

In order to explore the selectivity of the dianionic oxy-Cope rearrangement followed by an intramolecular aldol addition, 2-propenyllithium<sup>110</sup> was used. In this addition it was interesting to know the configuration as well as the steric interaction of the methyl group of the nucleophile in the nature of the dianionic oxy-Cope rearrangement and the selectivity at the intramolecular aldol addition.

Complex **42** was treated with eight equivalents of 2-propenyllithium at  $-78^{\circ}\text{C}$ , and **143** was obtained in 74% as an orange-red solid.

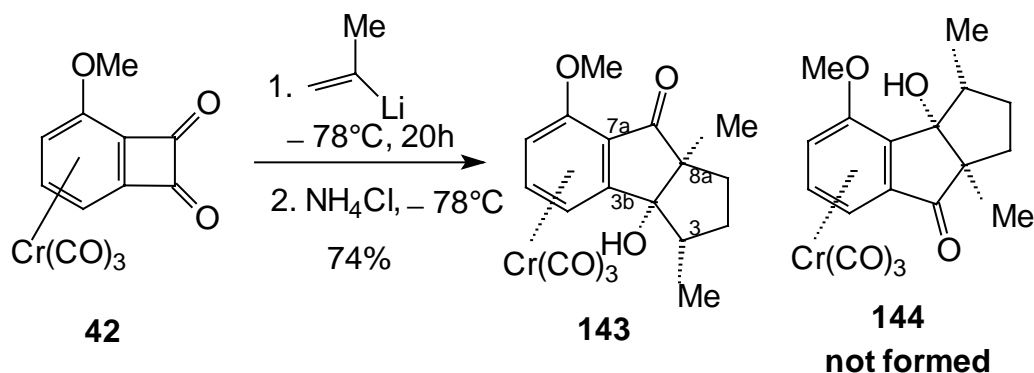

**143** was identified by comparison of its spectroscopic data with the corresponding compound obtained from the unsubstituted complex.<sup>96</sup> In the  $^1\text{H}$  NMR spectrum, a clear doublet for methyl group C-3 at  $\delta = 1.99$  with  $J = 6.90$  Hz and for C-8a a singlet at  $\delta = 1.44$  indicated the compound **143**. The  $^{13}\text{C}$  NMR value of the quaternary bridged carbon atoms between aromatic and cyclopentanone C-7a and the C-3b identified **143**. In the  $^{13}\text{C}$  NMR spectrum of two complexes **135** and **137** (see in chapter 6.3.3), the  $\delta$  value of the quaternary atoms C-7a and C-3a were found different. In the complex **135**, where the carbonyl group and methoxy group lies in the same side, the carbon atom between the carbon atom containing the methoxy group and the carbonyl carbon atom (C-9a) came at  $\delta = 130$  while the next quaternary carbon atom near to hydroxyl group C-5b comes at  $\delta = 85$ . If these carbon values were compared with the complex **143**, both carbon atoms values  $\delta = 130.3$  for C-7a and  $\delta = 83.4$  for C-3b, matched with complex **135**. This shows that the complex observed was **143**, but not **144**. However, the relative configuration of the complex **143** could not be confirmed from the spectral data. As explained in the previous examples, intramolecular aldol addition takes place exclusively by attack of the enolate at the ketone from the face opposite to the chromium moiety to give **143**. Consequently, the cyclopentene and hydroxyl

groups are bent towards the chromium side. The formation of selective **143** could be explained as follow:

When 2-propenyllithium was added to complex **42**, two propenyl groups were added exclusively from the face opposite to the chromium resulting *syn* or *cis* adduct **145**. This *syn* dipropenyl adduct **145** underwent the dianionic oxy-Cope rearrangement to form dienolate intermediate **146**. This intermediate **146** could lead two possible intermediates **146b** and **146b** at the protonation step, which undergo intramolecular aldol addition resulting in the products **143** and **144** respectively. However, in the above reaction only one product **143** was obtained indicating that only the intermediate **146a** was formed after the protonation. This shows that the formation of the intermediate **146a** is more favored than the formation of intermediate **146b**, which could be explained by the chelating as well as the electron donating effect of the methoxy group. This reaction indicated that the methyl group in the 2-propenyllithium did not play a significant role in the selectivity of the intramolecular aldol addition.

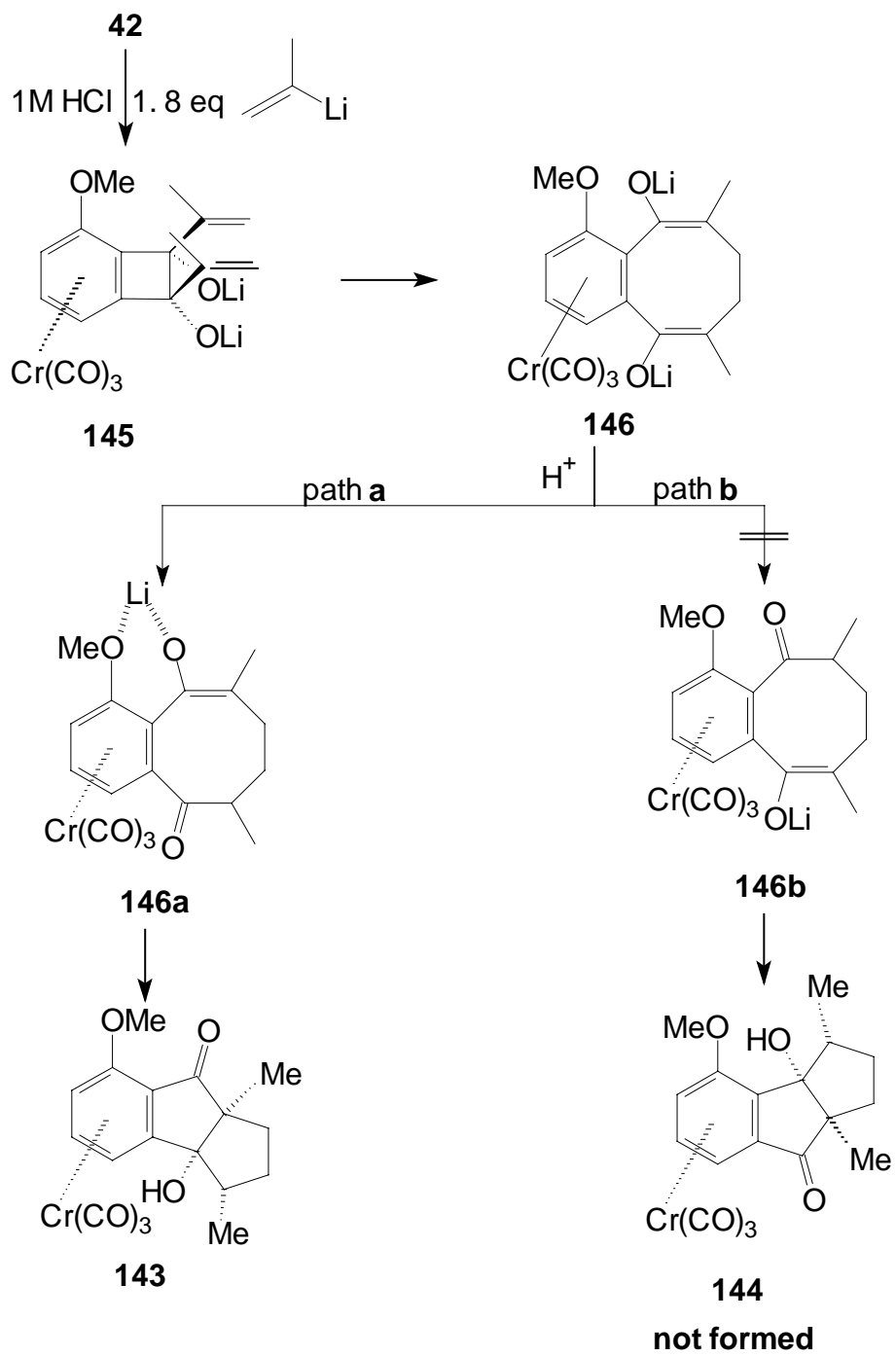

#### 6.4.2 Double Addition of 1-Ethoxy-1-Lithioethene to 3-Methoxybenzocyclobutenedione Complex **42**

To explore the selectivity with a more crowded and electron rich nucleophile, 1-ethoxy-1-lithioethene was added to 6-methoxybenzocyclobutenedione **42** at  $-78^{\circ}\text{C}$ , and **145** was obtained as a red solid in 67% yield as only one diastereomer.

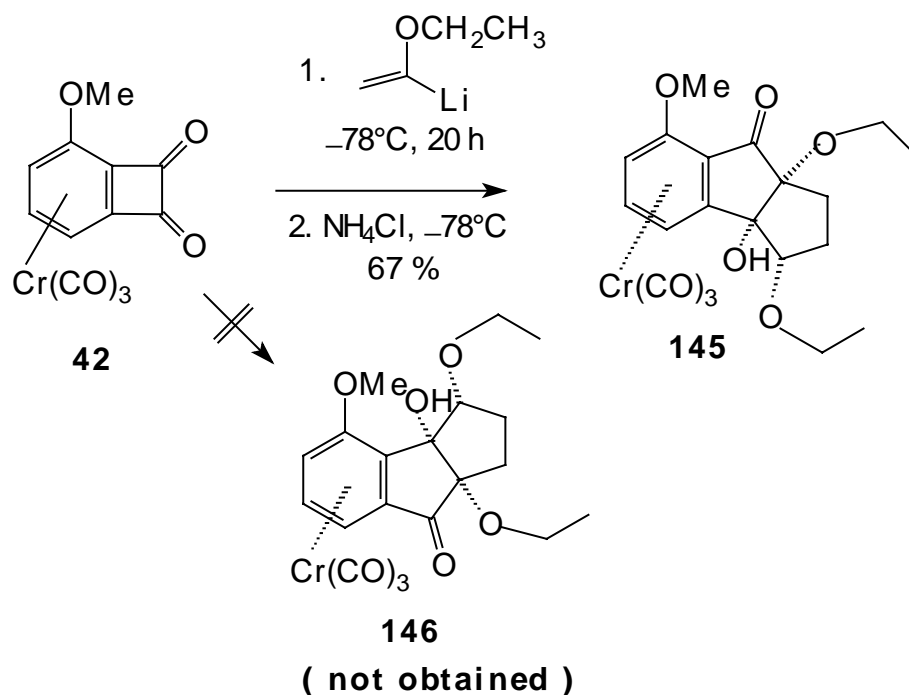

The complex **145** was identified by comparing the spectral data with the similar product from the unsubstituted complex.<sup>105</sup> As in previous examples, it was expected that the *syn* addition was followed by the dianionic oxy-Cope rearrangement forming benzocyclooctandienolate intermediate. At the protonation step, the selective intramolecular aldol addition takes place from the face opposite to the chromium giving product **145**.

### 6.4.3 Addition of Lithiated methoxyallene to 3-Methoxybenzocyclobutenedione complex **42**.

Allenes are sterically less demanding in compared to normal alkenes since the central carbon atom is *sp* hybridized in opposite to *sp*<sup>2</sup> in the normal alkenes. Therefore it is important to explore the selectivity of the dianionic oxy-Cope rearrangement followed by an intramolecular aldol addition using a lithiated allene as nucleophile. The simplest representative and most easily available alkoxyallene is methoxyallene, which can be easily metallated at C-1 by treatment with butyllithium between  $-78^{\circ}\text{C}$  and  $-30^{\circ}\text{C}$  and has been used for many syntheses.<sup>108,</sup><sup>109</sup> Eight equivalents of lithiated methoxy allene were added to the 6-methoxybenzocyclobutenedione complex **42** at  $-78^{\circ}\text{C}$ , and a red solid **147** was obtained in 59 % yield after hydrolysis.

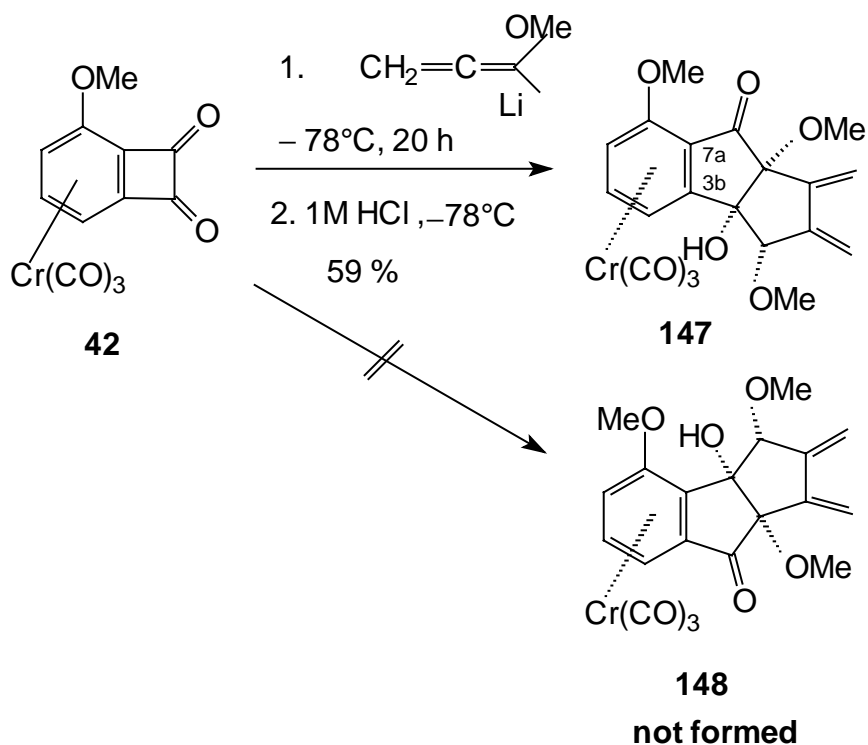

The product **147** was identified comparing the spectral data with those of corresponding product from the unsubstituted complex.<sup>105</sup> The spectral data confirmed that the product was only one diastereomer. The carbon C-3b in the



unsubstituted complex shown in  $^{13}\text{C}$  NMR signal at  $\delta = 121.9$  and the C-7a at  $\delta = 97.8$ , while in **147** the C-3b was observed at  $\delta = 113.5$  and C-7a was at  $\delta = 94.8$ . This indicates that due to the methoxy group near to the C-7a, the value was higher in complex **147** than in the unsubstituted complex while the second carbon C-3b shown the same value as in the unsubstituted complex. This indicates that the product was **147**, but not **148**. As explained in the previous examples, the intramolecular aldol addition takes place exclusively by attack of the enolate at the ketone from the face opposite to the chromium moiety to give **147**. Consequently, the cyclopentene and hydroxyl groups are bent towards the chromium side. A dianionic oxy-Cope rearrangement followed by an intramolecular aldol addition with methoxy allene also showed a high selectivity as in previous examples. Thus the steric differences between the allene and alkane did not effect significantly to the selectivity of the dianionic oxy-Cope rearrangement followed by an intramolecular addition.

#### **6.4.4 Double Addition of 1-Cyclopentenyllithium to 3-Methoxybenzocyclobutenedione Complex 42.**

The dianionic oxy-Cope rearrangement followed by an intramolecular aldol addition with vinylolithium, substituted vinylolithium and lithiated allenes showed a high degree of selectivity and good yields with high diastereoselectivity. It was important to know whether the same result will also be found with lithiated cycloalkenes like cyclopentene. 1-cyclopentenyllithium was prepared by treating 1-bromocyclopentene in THF with lithium sand.<sup>110</sup> The 1-cyclopentenyllithium was added to the 6-methoxybenzocyclobutenedione complex **42** at  $-78^\circ\text{C}$ , and an orange-red solid **149** was obtained in 89% yield as only one diastereomer.

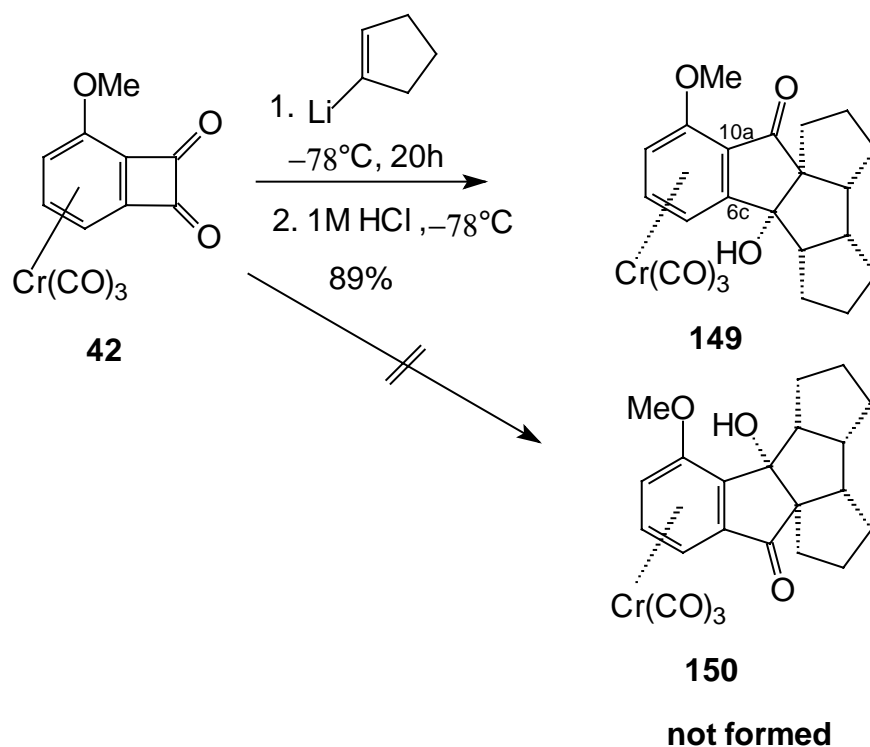

The complex **149** was identified comparing the spectral data with those of corresponding product from unsubstituted complex<sup>96</sup> and the mono cyclopentenyllithium added product **135**. In spectral data of the identified complex **135**, the carbon atom, between carbon atom containing the methoxy and the carbonyl carbon C-9a, was observed at  $\delta=130$  and the next quaternary carbon atom near to hydroxyl group C-5b shown at  $\delta = 85$ . If these carbon values are compared with corresponding carbon atoms of the complex **149**, both carbon atoms values  $\delta = 132$  for C-10a and  $\delta = 83.4$  for C-6c is shown similar values with identified complex **135**. Thus these spectrum shows that the product was **149** as only one diastereomer. As explained in the previous examples, the intramolecular aldol addition takes place exclusively by attack of the enolate at the ketone from the face opposite to the chromium moiety to give **149**. Consequently, the cyclopentene and hydroxyl groups are bent toward the chromium side. The relative configuration and the product was later confirmed from the analysis of a

crystal structure (fig.12). This indicates that the steric bulkiness upto five membered cyclic nucleophiles allowed a high selectivity as other vinyl nucleophiles in the dianionic oxy-Cope rearrangement followed by an intramolecular aldol addition. The regioselective formation of product **149** could be explained by taking the chelation as well as the electronic effect of methoxy group into account.

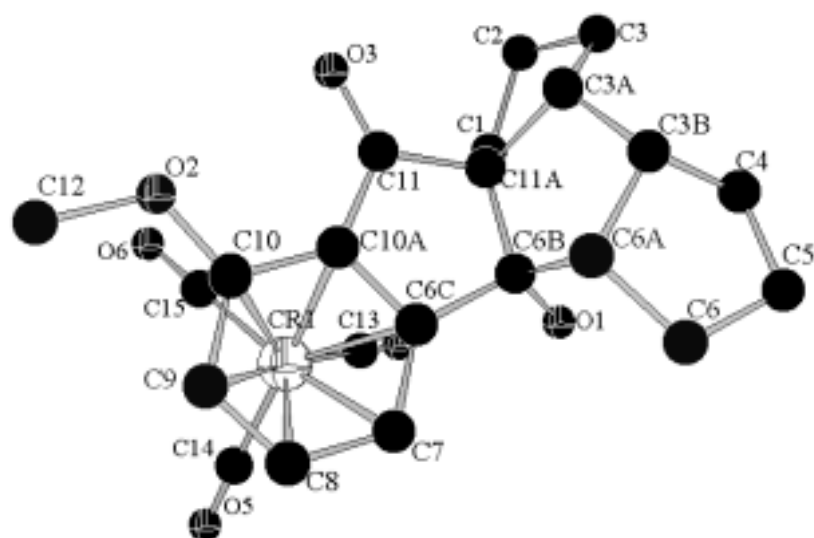
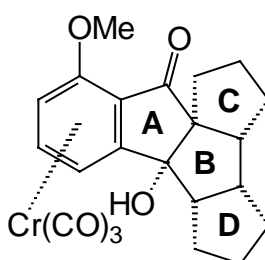

Fig.12: Structure from complex **149** in the crystal.



**149**

Bond length in Å			
Cr - C6c	2.211(3)	C1 - C2	1.518(6)
Cr - C7	2.221(4)	C1 - C11	1.535(5)
Cr - C8	2.159(4)	C2 - C3	1.506(6)
Cr - C9	2.213(4)	C3 - C3a	1.526(6)
Cr - C10	2.256(4)	C3a - C3b	1.526(6)
Cr - C10a	1.408(6)	C3a - C11a	1.565(5)
Cr - C13	1.833(4)	C3b - C4	1.532(6)
Cr - C14	1.836(4)	C3b - C6a	1.526(6)
Cr - C15	1.814(5)	C4 - C5	1.524(6)
C5 - C6	1.523(6)	C6 - C6a	1.537(5)
C6a - C6b	1.559(5)	C6b - C6c	1.508(5)
C6b - C11a	1.548(6)	C6c - C7	1.393(5)
C6c - C10a	1.408(6)	C7 - C8	1.399(5)
C8 - C9	1.383(6)	C9 - C10	1.382(6)
C10 - C10a	1.418(5)	C10a - C11	1.465(6)
C11 - C11a	1.523(6)		

In the fig 12, the cyclopentene rings **C**, **D** and the hydroxyl group are bent toward the side of chromium (*endo*). This gave the evidence that the intramolecular aldol addition takes place exclusively by attack of the enolate at the ketone from the face opposite to the chromium moiety to give **149**. The second cyclopentane ring, **B** was bent away from the face of chromium moiety with angle 109.4(3)° [C6a-C6b-C6c] and 111.5(3)° [C3a-C11a-C11] which might be the sterically more demanding configuration in this complex **149**. The chromium carbonyl group is oriented in such a way that one CO group lies just beneath cyclopentane ring which might be the more steric shielding to attack from opposite side of chromium. However, the methoxy group in the fig. 12 is bent away from the cyclopentane ring while in the case of benzocyclobutenone and benzocyclobutenedione complex the methoxy group is bent towards the four-membered ring.

A similar type of products had been observed when the symmetric squarate **131** was treated with 1-cyclopentenyl lithium resulting in a mixture of three diastereomers **151**, **152a** and **152b**.<sup>112</sup>

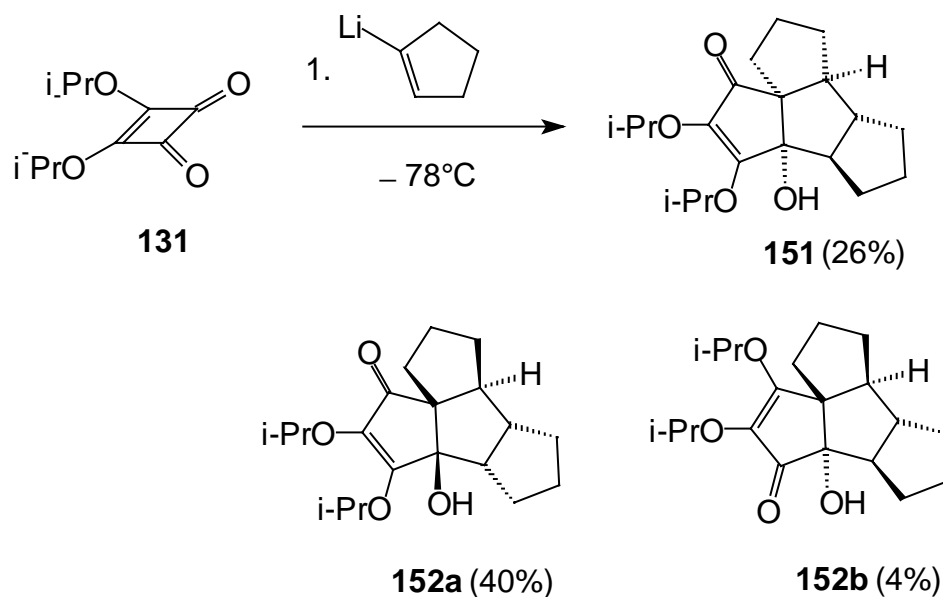

This shows that the chromium fragment and the methoxy group can play an important role for regio- as well as stereoselectivity in the dianionic oxy-Cope rearrangement and aldol adducts.

## 7 Dianionic oxy-Cope with Heterocyclic Compounds

As discussed in chapter 6, a dianionic oxy-Cope rearrangement followed by a selective intramolecular aldol addition proceeds with high selectivity demonstrating the potential of this reaction in the synthetic methods. To explore whether or not such selectivity will also work in the case of heterocyclic nucleophiles, some non-aromatic as well as aromatic heterocyclic alkenyllithiums were treated with the 6-methoxybenzocyclobutenedione **42**.

## 7.1 Non Aromatic Heterocyclic Alkenyllithium

5-Lithio-2,3-dihydrofuran was added to the 6-methoxybenzocyclobutenedione **42** at  $-78^{\circ}\text{C}$ , and the mixture of diastereomers **153** and **154** was obtained in 72% yield after hydrolysis.

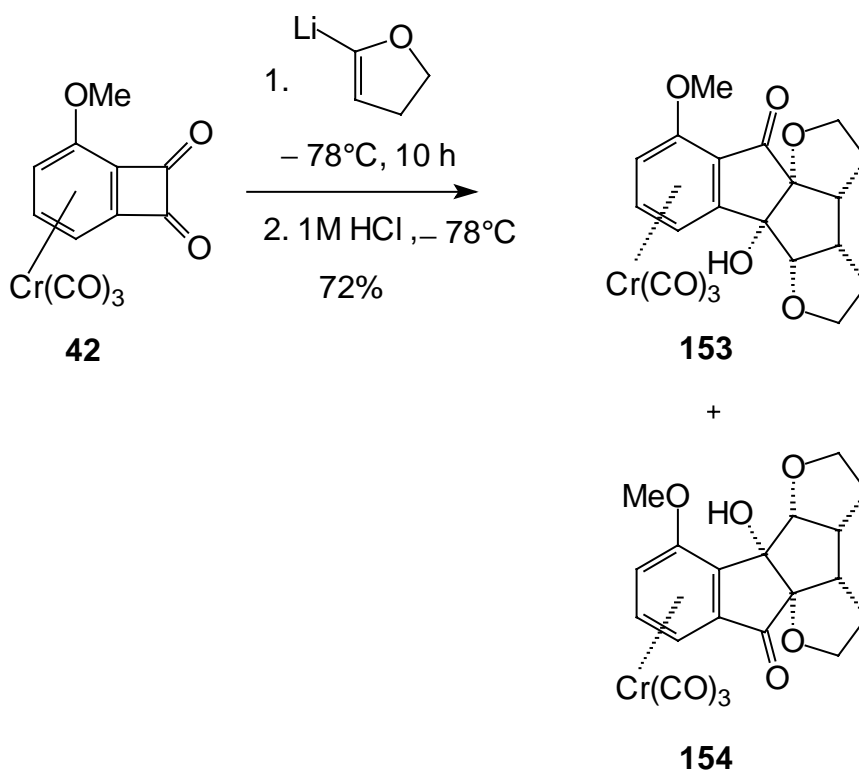

The complexes **153** and **154** were identified by comparing the spectroscopic data with the similar product from the unsubstituted complex.<sup>114</sup> However,  $^1\text{H}$  NMR and  $^{13}\text{C}$  NMR spectrum, there are double signals for each signal indicating the presence of two products. However, the mixture of two regioisomers could not be separated so far. The COSY NMR indicated two similar complexes and from the integration of the methoxy signals, the composition of the mixture of **153** and **154** were calculated approximately 1:1. By comparing the chemical shifts of C-8a and C-4c with the corresponding product from unsubstituted complex<sup>114</sup> the complexes **153** and **154** were proposed. This was a surprising result because the dianionic

oxy-Cope rearrangements followed by an intramolecular aldol addition with vinyl lithium and others had shown high selectivity resulting only one product but in contrast this reaction yielded diastereomeric mixtures of **153** and **154**.

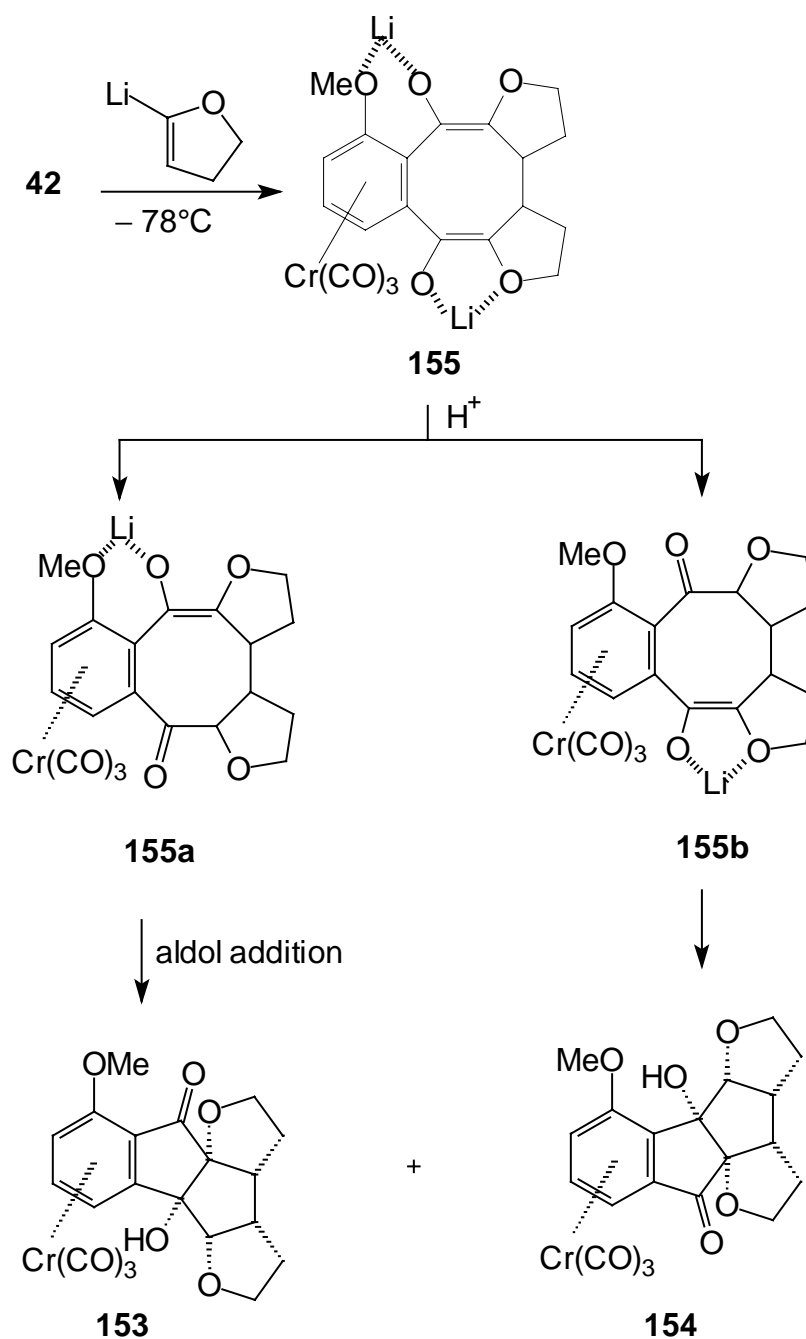

The formation of two regioisomers could be explained by taking the chelating effect into account. In contrast to earlier nucleophiles, 1-lithio 2,3-dihydrofuran contains an oxygen atom with a lone pair of electrons. Therefore such a nucleophile can have a chelating effect with lithium. The 1-lithio 2,3-dihydrofuran first added to the 6-methoxybenzocyclobutenedione complex **42** from face opposite to chromium moiety resulting *syn* or *cis* addition which transformed into benzocyclooctadienolate intermediate **155**, by dianionic oxy-Cope rearrangement. In this intermediate, *both* lithium cations could chelate with the oxygen of the furane or methoxy group as shown in **155**. In contrast to the other case discussed so far none of the enolate moiety is significantly more stabilized than the other. Therefore it is obvious that both intermediates **155a** and **155b** are formed after protonation which could undergo later intramolecular aldol additions resulting both products **153** and **154** in equal.

Such regiocontrol determined products were also observed in an addition of alkenylmetal to diisopropyl squarate with poor selectivity. This process when carried out with 5-lithio-2, 3-dihydrofuran four isomeric racemic products in 52%, 15%, 6% and 4% yield respectively.<sup>113</sup> Such a stereochemical change due to the chelation effect with heteroatoms was also observed in the unsubstituted complex. In the addition of heterocyclic alkenyllithium to the complex **142**, an eight membered transition state **156** was formed as a result of a dianionic oxy-Cope rearrangement. Although there are two possibilities for protonation in the intermediate **157**, only complex **158** was obtained.<sup>114</sup> The reason for this selectivity was explained taking into account the chelating effect of lithium with a hetero atom in the heterocyclic compounds as shown below.



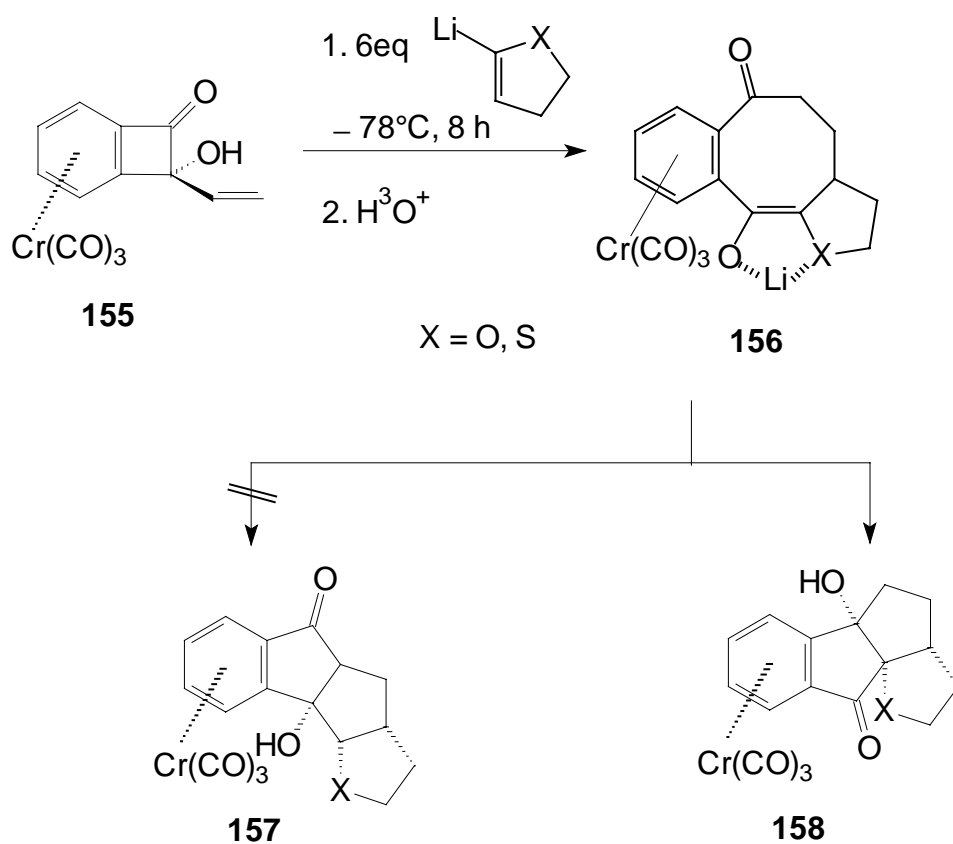

## 7.2 Nucleophilic Addition of 2-Lithio-3,4-dihydro-2H-pyran to 3-Methoxy-benzocyclobutenedione Complex **42**

After getting the poor selectivity in the dianionic oxy-Cope rearrangement followed by intramolecular aldol adduct with 5-lithio-2,3-dihydrofuran, the next similar nucleophile, 2-lithio-3,4-dihydro-2H-pyran was used for addition to the 6-methoxybenzocyclobutenedione complex **42**. The 2-lithio-3,4-dihydro-2H-pyran was prepared by treating 3,4-dihydro-2H-pyran with the butyllithium in THF. The 6 equivalent of the 2-lithio-3,4-dihydro-2H-pyran were added to the 6-methoxybenzocyclobutenedione complex **42** at  $-78^\circ\text{C}$ , an orange-red product **159** was obtained in 60% yield after hydrolysis.

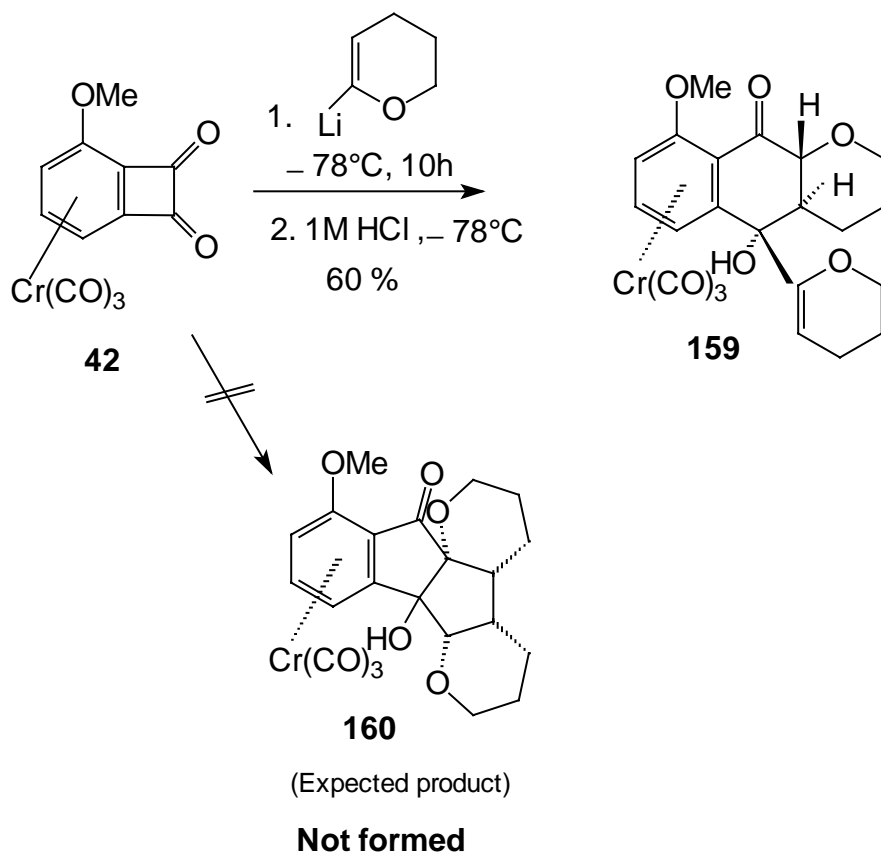

Normally **160** was the expected in this reaction product. However, the  $^1\text{H}$  NMR showed signals for three more protons above  $\delta = 4$  which do not match with the spectral data of the complex **160** but indicates the presence of an alkenyl proton and an ether proton. Similarly, the carbonyl absorption in the IR spectrum was at  $1710\text{ cm}^{-1}$ , which is slightly lower than the five membered cyclic ketone and indicated the six membered ketone instead. The other spectra also do not exactly match the product **160**. Therefore the product could not be identified completely from the spectral data analysis. However, after getting the crystal structure (fig. 13) from the complex **159** it was confirmed that the product was no that of a dianionic oxy-Cope rearrangement followed by an intramolecular aldol addition but anion driven rearrangement product **159**.

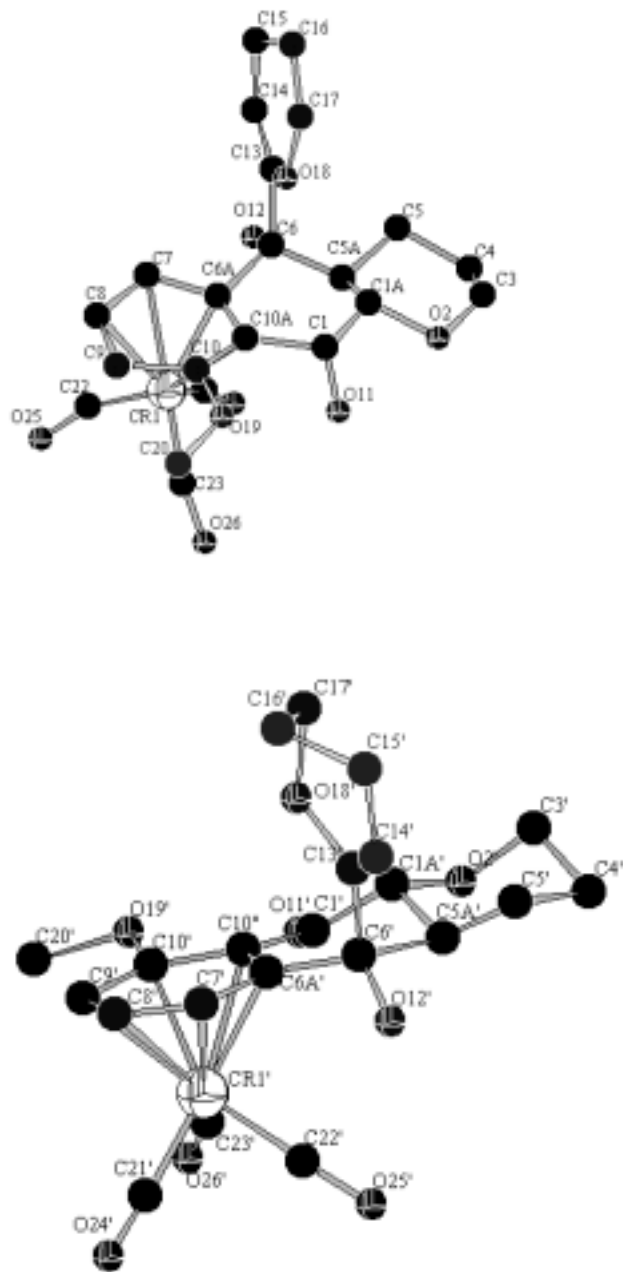
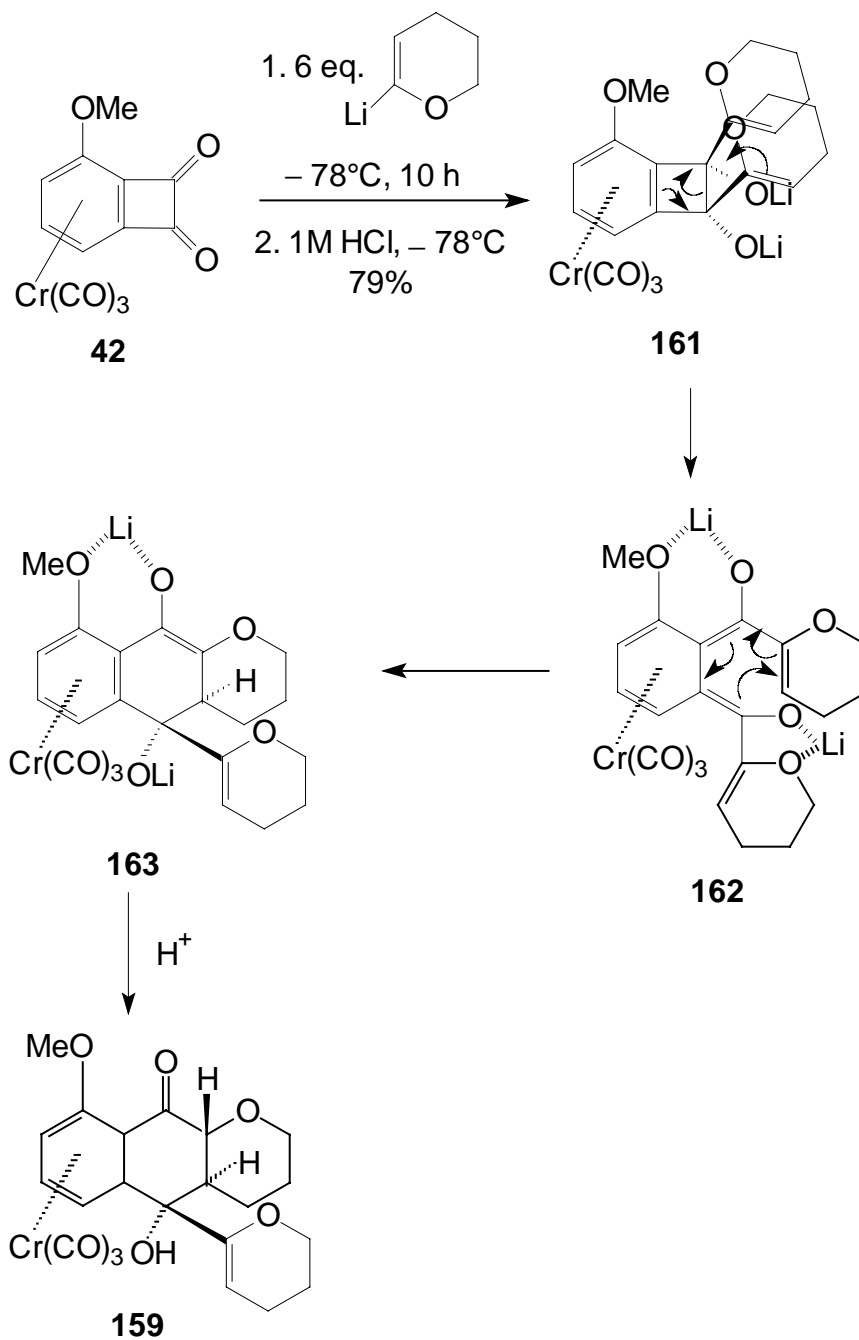

Fig. 13: Crystal structure from the complex **159**.

Bond length in Å			
C1 - C1a	1.25(5)	C1' - C1a'	1.46(6)
C1a - C10a	1.57(6)	C1a' - C10a'	1.49(6)
C1a - C5a	1.68(4)	C1a' - C2a'	1.68(6)
C3 - C4	1.51(5)	C2a' - C5'	1.26(6)
C4 - C5	1.56(5)	C2a' - C6'	1.58(6)
C5 - C5a	1.53(5)	C3' - C4'	1.58(6)
C5a - C6	1.52(5)	C3a' - C6'	1.47(6)
C6 - C6a	1.57(5)	C3a' - C7'	1.35(5)
C6 - C13	1.53(4)	C3a' - C10a'	1.53(4)
C6a - C7	1.41(5)	C4' - C5'	1.58(6)
C6a - C10a	1.45(4)	C6' - C13'	1.54(4)
C7 - C8	1.43(5)	C7' - C8'	1.33(4)
C8 - C9	1.47(4)	C8' - C9'	1.40(4)
C9 - C10	1.50(5)	C9' - C10'	1.36(6)
C10 - C10a	1.27(6)	C10' - C10a'	1.41(6)
C13 - C14	1.33(4)	C13' - C14'	1.34(4)
C14 - C15	1.53(5)	C14' - C15'	1.54(5)
C15 - C16	1.53(4)	C15' - C16'	1.54(6)
C16 - C17	1.53(4)	C16' - C17'	1.54(4)

The relative configuration was identified from the crystal structure of **159**.

The unexpected product **159** can be explained by the following anion driven rearrangement mechanism: The lithio-3,4-dihydro-2H-pyran added to either one of the carbonyl groups of 6-methoxybenzocyclobutenedione complex **42** from the face opposite to the chromium moiety resulting *anti* or *cis* diadduct **161**. The intermediate **161** does not rearrange as in the previous dianionic oxy-Cope rearrangement.



Apparently the steric bulk of the six membered rings (3,4-dihydro-2H-pyran) does not facilitate a conformation, which is suitable for a dianionic oxy-Cope rearrangement. Instead, an anionic ring opening takes place as in the 6-methoxybenzocyclobutenone complex **43**, forming the *ortho*-quinodimethane intermediate **162** whose configuration appears to be more favorable to the

thermally allowed disrotatory electrocyclic ring closer to the product **163**. Presumably for steric reasons, the 2-dihydropyran substituent ends up in an *anti* position with respect to the  $\text{Cr}(\text{CO})_3$  group. Protonation of **163** finally leads to **159**.

So far the causes of the anion driven rearrangement could not be confirmed. Remarkably, this type of reaction was observed only in the addition of lithiated 3,4-dihydro-2*H*-pyrane to **42**, while under the similar condition the other nucleophiles underwent a dianionic oxy-Cope rearrangement followed by intramolecular aldol addition. This might be a combined effect of chelation between oxygen and lithium counter ion and steric bulk of lithio-3,4-dihydro-2*H*-pyran. It was already found in the unsubstituted complex **37** that a dianionic oxy-Cope rearrangement was found difficult in case of larger rings than seven carbon atoms.<sup>114</sup> Anion driven rearrangements of the 1-vinylcyclobutanols are rare.<sup>116</sup> Interestingly, the unsubstituted complex **32** underwent such a rearrangement<sup>71</sup> with 1-lithiated-1-methoxy-allene to give **166** via intermediate **164** and **165**.

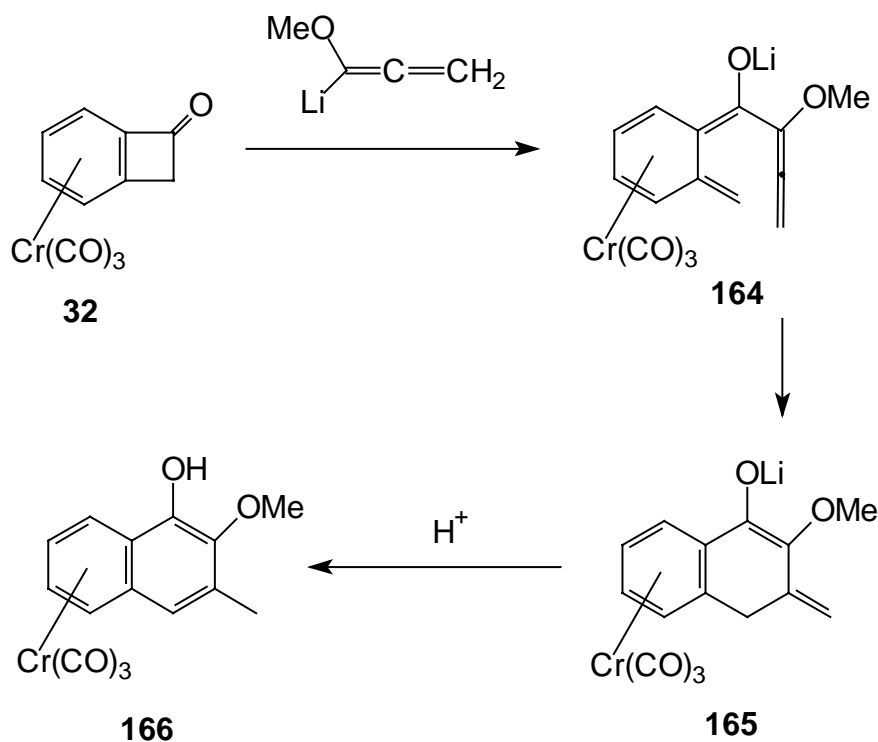

In contrast to the case discussed here, the aromatization of the annellated ring presumably was the driving force.

### 7.3 Addition of 2-Lithiofuran to the 3-Methoxycyclobutenedione Complex 42

As explained above, dianionic oxy-Cope rearrangements were performed very selectively with different vinyl nucleophiles. There was no selectivity in the aldol addition with 5-lithio-2,3-dihydrofuran. It was therefore interesting to explore such reaction with aromatic nucleophiles. In these cases the dianionic oxy-Cope rearrangement would lead to an elimination of the aromaticity, which is normally not easy. The complex **42** was treated with an aromatic nucleophile, the 2-lithiofuran at  $-78^{\circ}\text{C}$  and the distal ring-opening product **167** was obtained in 71 % yield.

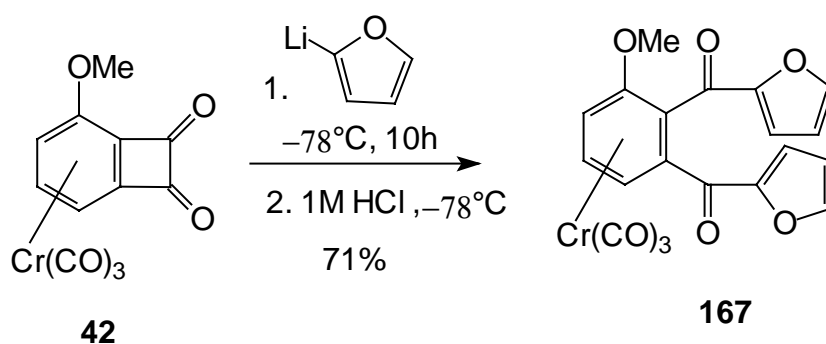

A similar result was also obtained in the case of the unsubstituted complex.<sup>113, 114</sup> This indicates that the dianionic oxy-cope rearrangement was not observed when the lithiated aromatic nucleophiles were added.

## 8 Approach to the 6-Trifluoromethylbenzocyclobutenone complex **168** and 3-Trifluorobenzocyclobutenedione Complex **169**

Although there are many methods for the preparation of benzocyclobutenone and benzocyclobutenedione, the methoxy substituted benzocyclobutenone and benzocyclobutenedione was prepared in high yield using the [2+2] cycloaddition reaction. Therefore, it was thought to syntheses an electron withdrawing substituted complexes, 6-trifluoromethylbenzocyclobutenone complex **169** and 3-trifluoromethylbenzocyclobutenedione complex **168** by using the [2+2] cycloaddition reaction as used for the synthesis of methoxy substituted benzocyclobutenone and benzocyclobutenedione complexes.<sup>52</sup>

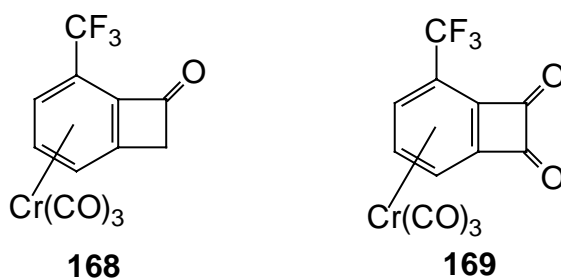

### 8.1 Preparation of Uncoordinated 6-Trifluoromethylbenzocyclobutenone (**173**) and 3-Trifluoromethylbenzocyclobutenedione (**175**)

#### 8.1.1 Synthesis of 6-Trifluoromethylbenzocyclobutenone (**173**)

6-Trifluoromethylbenzocyclobutenone (**173**) was prepared by using the same procedure as for the synthesis of 6-methoxybenzocyclobutenone,<sup>52</sup> the [2+2] cycloaddition of benzyne and 1,1-diethoxyethene. However, as 2-bromotrifluoromethylbenzene was not commercially available so it was thought to use the 3-bromo-trifluoromethylbenzene for the generation of benzyne. 3-Bromo-trifluoromethylbenzene (**170**) was treated with sodium amide in THF, the benzyne



intermediate **171** was formed and in the presence of 1,1-diethoxyethene, [2+2] cycloadduct **172** was obtained regioselectively in 46 % yield. After treatment of **172** with 1M HCl, 6-trifluoromethylbenzocyclobutenone (**173**) was obtained in 94 % yield.

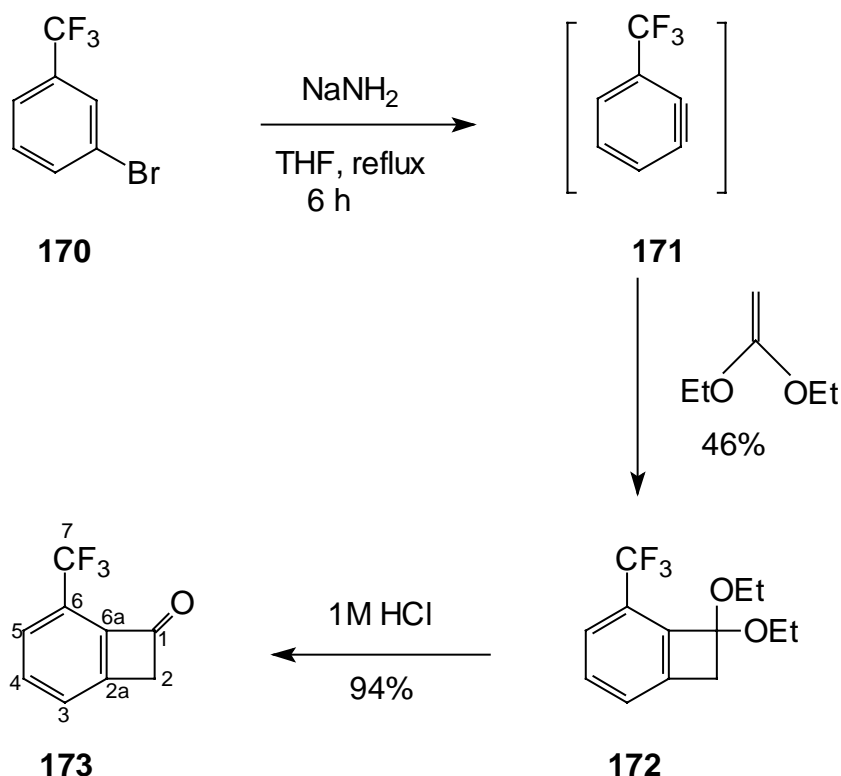

Compound **173** was identified by inspection of its spectral data. In the IR spectrum, strong bands at  $1771\text{ cm}^{-1}$  for ketone and at  $1325\text{ cm}^{-1}$  for C-F, and in  $^{13}\text{C}$  NMR spectrum at  $\delta = 121.0$  for C-7 with  $^1J_{\text{C-F}} = 272\text{ Hz}$ ,  $122.2$  for C-6 with  $^2J_{\text{C-F}} = 36\text{ Hz}$ ,  $125.13$  for C-5 with  $^3J_{\text{C-F}} = 4.5\text{ Hz}$  and  $183.3$  for C-1 indicate compound **173**. The 1,1-diethoxyethene was prepared by 1,2-elimination from 1,1-diethoxy-2-bromoethane using the strong base potassium *tert*-butoxide in *tert*-butanol.<sup>53</sup>

### 8.1.2 Preparation of 3-Trifluoromethylbenzocyclobutenedione (**175**)

3-Trifluoromethylcyclobutenedione (**175**) was prepared applying the same procedure as for the synthesis of 3-methoxybenzocyclobutenedione (**175**).<sup>57</sup> 6-trifluoromethylbenzocyclobutenone (**173**) was brominated with *N*-bromosuccinimide in presence of the radical initiator dibenzoylperoxide (DBP) by refluxing for 2-5 days in carbon tetrachloride. 2,2-Dibromo-6-trifluoromethylbenzocyclobutenone (**174**) was obtained as a colorless solid in 46 % yield. After hydrolysis of 2,2-dibromo-6-trifluorobenzocyclobutenone by refluxing with 50% H<sub>2</sub>SO<sub>4</sub> for 24 hours, 3-trifluoromethylbenzocyclobutenedione **175** was obtained as a yellow solid in 56 % yield.

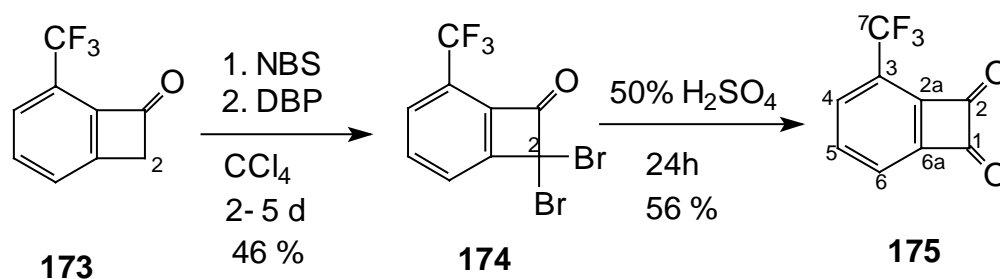

The compound **174** and **175** were identified by their spectral data. **174** was identified by comparison with the related compound **173**. In the <sup>1</sup>H NMR spectra of **174**, a signal for 2-H is lost. MS indicated two bromine atoms. In the IR spectrum of **175** the band at 1798 cm<sup>-1</sup>, which is higher value than benzocyclobutenedione (1777 cm<sup>-1</sup>), indicated the presence of cyclobutene diketone having electron withdrawing group. In the <sup>13</sup>C NMR spectrum, signals at  $\delta = 120.7$  with <sup>1</sup>J<sub>C-F</sub> = 272.2 Hz for C-7,  $\delta = 124.5$  with <sup>2</sup>J<sub>C-F</sub> = 37.4 Hz for C-3,  $\delta = 132.0$  with <sup>3</sup>J<sub>C-F</sub> = 4.2 Hz for C-4),  $\delta = 190.0$  for C-1,  $\delta = 192.5$  for C-2. Thus from the analysis of <sup>1</sup>H NMR, <sup>13</sup>C NMR, IR and MS indicates the presence of **175**.

## 8.2 Preparation of the 6-Trifluoromethylbenzocyclobutenone Complex **168**

The direct complexation of 6-trifluoromethylbenzocyclobutenone with Kündig's reagent failed.<sup>59</sup> However, the 6-trifluoromethylbenzocyclobutenone complex **168** can be prepared by refluxing the 1,1-diethoxy-6-trifluoromethylbenzocyclobutenone **172** with chromiumhexacarbonyl in a 10:1 mixture of Bu<sub>2</sub>O/THF over 24 hours. After evaporation of the solvent, the complex **176** was obtained as a yellow solid in 30% yield. Treatment of **176** with 50% HCl gave 6-trifluoromethylbenzocyclobutenone complex **168** in 92% yield as an orange solid.

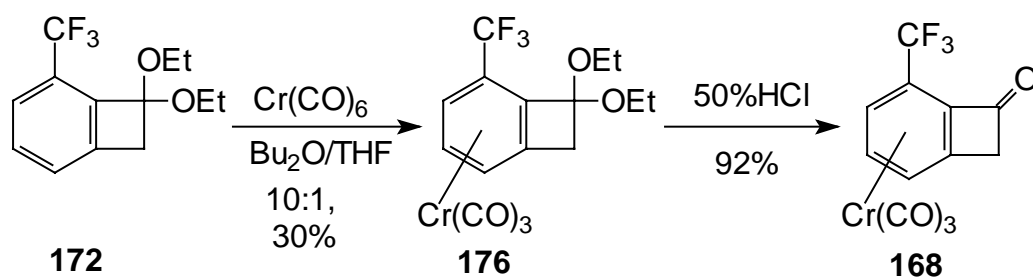

The complex **176** was identified by inspection of the spectral data and comparing with the corresponding ligand. **168** was identified from its spectral data analysis. Later, the constitution of **168** was confirmed by the crystal structure (fig 14).

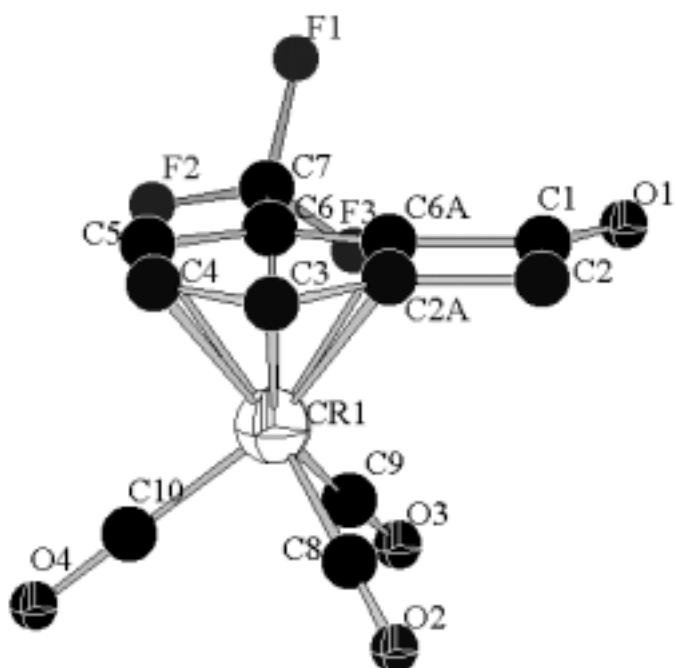
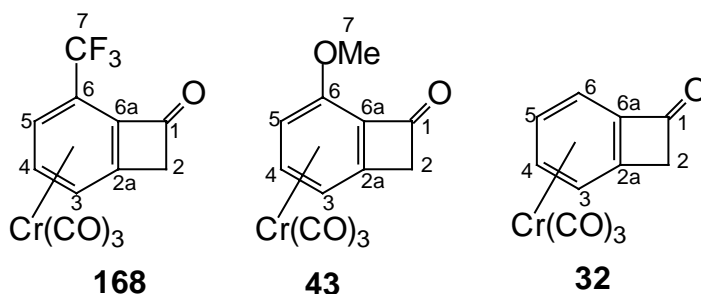

Fig.14 Crystal structure from complex **168**

Bond length in Å			
Cr - C2a	2.188(10)	C1 - C2	1.581(17)
Cr - C3	2.216(12)	C1 - C6a	1.53(2)
Cr - C4	2.170(12)	C2 - C2a	1.522(14)
Cr - C5	2.212(8)	C2a - C3	1.408(17)
Cr - C6	2.172(14)	C2a - C6a	1.341(19)
Cr - C6a	2.190(15)	C3 - C4	1.380(18)
Cr - C8	1.809(12)	C4 - C5	1.415(18)
Cr - C9	1.858(12)	C5 - C6	1.400(19)
Cr - C10	1.807(13)	C6 - C6a	1.41(2)
		C6 - C7	1.51(2)

A comparison of the bond lengths with those of the methoxy substituted complex (see fig.2) did not show significant differences of the bond lengths.



Comparison of the bond length between benzocyclobutenone complexes in Å			
Atom no.	168	43	32 <sup>62b</sup>
C1 - C2	1.581(17)	1.556(4)	1.55(2)
C1 - C6a	1.53(2)	1.502(3)	1.41(2)
C2 - C2a	1.522(14)	1.523(3)	1.54(2)
C2a - C3	1.408(17)	1.387(4)	1.34(2)
C2a - C6a	1.341(19)	1.428(3)	1.41(2)
C3 - C4	1.380(18)	1.411(3)	1.37(2)
C4 - C5	1.415(18)	1.415(3)	1.45(2)
C5 - C6	1.400(19)	1.410(3)	1.36(2)
C6 - C6a	1.41(2)	1.217(3)	1.37(2)
C6 - C7	1.51(2)		

The torsion angles  $C3-C2a-C6a-C1 = -176.4(10)^\circ$ ,  $C6-C6a-C2a-C2 = 176.7(13)^\circ$  indicating that the cyclobutene ring is bend with  $4^\circ$  toward the chromium side. This is interesting since such a bending was not found in the case of methoxy substituted benzocyclobutenone complex **43**, nor in the unsubstituted complex **32**.<sup>62</sup> However, this was observed in the case of 3-methoxybenzocyclobutenedione complex **42** and the unsubstituted benzocyclobutenedione complex **37**, and the effect was explained by the electron withdrawing chromium

carbonyl and two ketone groups.<sup>46</sup> Therefore, bending of cyclobutene ring by 4° towards the chromium at 6-trifluoromethylbenzocyclobutenone complex **168** indicates the electron withdrawing properties of trifluoromethyl substituent at the aromatic ring. None of the carbonyl groups of chromium carbonyl moiety lies just below the cyclobutene ring.

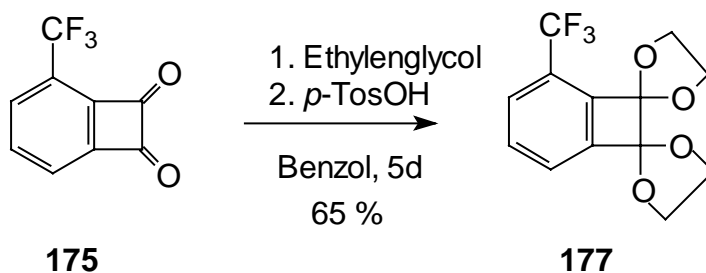

Fig. 15: The crystal view of **168** from the top of the chromium carbonyl

The four angles of cyclobutene ring in **168** are also found different as compared to the corresponding angle in the 6-methoxybenzocyclobutenone complex **43**. The bond angle  $C1-C2-C2a = 85.1(8)^\circ$ ,  $C1-C6a-C2a = 93.9(12)^\circ$ ,  $C2-C2a-C6a = 95.2(11)^\circ$ ,  $C2-C1-C6a = 85.8(10)^\circ$ . The angle of carbonyl carbon atom,  $C2-C1-C6a$  is  $90.08(18)^\circ$  in the case of 6-methoxybenzocyclobutenone complex **43** while this angle is less by  $5^\circ$  in the case of 6-trifluoromethylbenzocyclobutenone complex **168**. This deviation of angle might be the effect of the electron withdrawing property of the trifluoromethyl group at aromatic ring in **168**. Thus in the crystal structure (fig 14), it is clearly indicated that the trifluoromethyl group changed the electronic properties of the benzocyclobutenone complex as compared to the methoxy substituted benzocyclobutenone complex **43**.

### 8.3 Attempts to the 3-Trifluoromethylbenzocyclobutenedione Complex **169**

As the direct complexation of 6-trifluoromethylbenzocyclobutenone **173** failed, it is obvious that direct complexation of more electron withdrawing group bearing 3-trifluoromethylbenzocyclobutenedione **175** might be difficult. Therefore, the same complexation procedure, which was used for the synthesis of 3-methoxybenzocyclobutenedione complex,<sup>61</sup> was followed for the syntheses of 3-trifluoromethylbenzocyclobutenedione complex **169**. The two carbonyl groups of 3-trifluoromethylbenzocyclobutenedione **175** were first acetylated by refluxing **175** with ethyleneglycol in presence of *p*-toluenesulfonic acid as a catalyst in benzene using a water absorber for about 5 days. The bisacetal **177** was obtained as colorless solid in 65 % yield.



The complex **177** was identified by its spectroscopic data. Especially, after the acetalization of the compound **175**, the ketone signals are lost and in the <sup>1</sup>H NMR spectrum, two multiplets at  $\delta = 4.04$  and  $\delta = 4.18$  indicate the presence of two acetal group like in compound **177**. Similarly the IR and <sup>13</sup>C NMR also indicate the presence of the compound **177**.

The bisacetal trifluoromethylbenzocyclobutene **177** was then complexed with chromium by refluxing the **177** with the chromiumhexacarbonyl in a 10:1 Bu<sub>2</sub>O/THF for 24 hours. A yellow bisacetal trifluoromethylbenzocyclobutene complex **178** was obtained in 30 % yield.

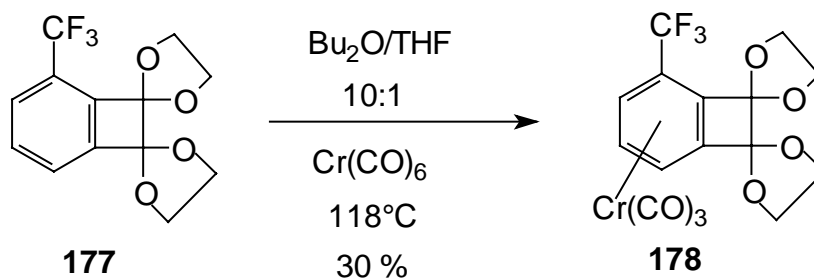

The complex **178** was identified by its spectroscopic data. Especially after the complexation the shifting of the aromatic proton signals from  $\delta = 7 - 8$  to  $\delta = 5$  to 6 in the  $^1\text{H}$  NMR spectrum and chromium carbonyl signal at  $\delta = 229.06$  in the  $^{13}\text{C}$  NMR spectrum, indicated the presence of complex **178**.

After hydrolysis it with conc. HCl, the ligand of 3-trifluoromethylbenzocyclobutenedione **175** was obtained in 92% yield. In several tries, only the decomplexed ligand **175** was obtained instead of the desired 3-trifluoromethylbenzocyclobutenedione complex **169**.

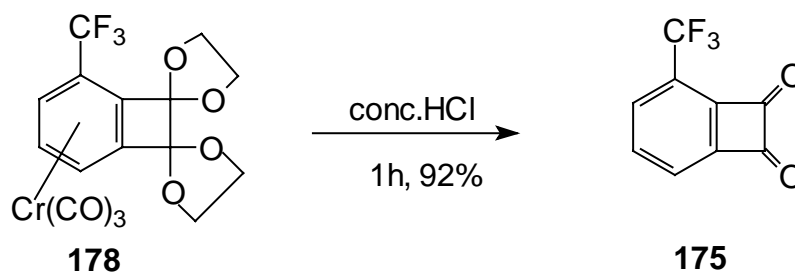

After few min of stirring the reaction mixture, the color changed from orange to light yellow. This decomplexation can be explained by taking account the electronic density in the aromatic ring of the trifluorobenzocyclobutenedione **175**. This decomplexation might be due to the smaller electron density at the aromatic ring by pulling the electron density toward the trifluoromethyl and to the carbonyl groups of the four membered ring. In a previous trial of complexation Brands<sup>44a</sup> found that the direct complexation in benzocyclobutenedione yields only about 4% of the complex and a study showed that the electron donating group like at aromatic ring increases the rate and yield of complexation.<sup>60</sup> This indicates that if



the electron density at aromatic ring is low, complexation with chromium carbonyl is difficult. From the crystal structure analysis of trifluoromethyl substituted mono ketone complex **168**, the cyclobutene ring bent by  $4^\circ$  from the plane of aromatic ring toward the chromium, which is half of the bending value found in the methoxy substituted diketone complex **42** and in the unsubstituted diketone complex **37**.<sup>46</sup> This leads to the conclusion that the electron density in trifluoromethyl substituted mono ketone complex is nearly half than that of diketone complex. Moreover, when one electron withdrawing carbonyl group introduced at the cyclobutene ring, the electron density is further reduced so that more difficult to complexation with such electron deficient compound. Therefore after treating with strong acid conc. HCl for 1h only the decomplexation diketone **175** was obtained. However, it might be possible to get complexed trifluoromethyl diketone if some mild deacetylating agents are used.

## C Summary and Conclusion

The main aim of this project is to explore the chemistry of the methoxy substituted benzocyclobutenone complex **43** and the methoxy substituted benzocyclobutenedione complex **42** in order to find reactivity different from that of the unsubstituted system. The 3-methoxybenzocyclobutenone complex **43** can be reduced diastereoselectively in high yield by lithium aluminum hydride at low temperature ( $-78^{\circ}\text{C}$ ).<sup>43</sup> Attempts directed to a kinetic resolution of the racemic **43** were made using the Noyori catalyst **60** in a transfer hydrogenation.<sup>64</sup> The complex **58** was obtained 46% yield with 6% *ee*. However, the study of Noyori indicated that the diastereoselectivity could be improved by changing the solvent and reaction conditions.

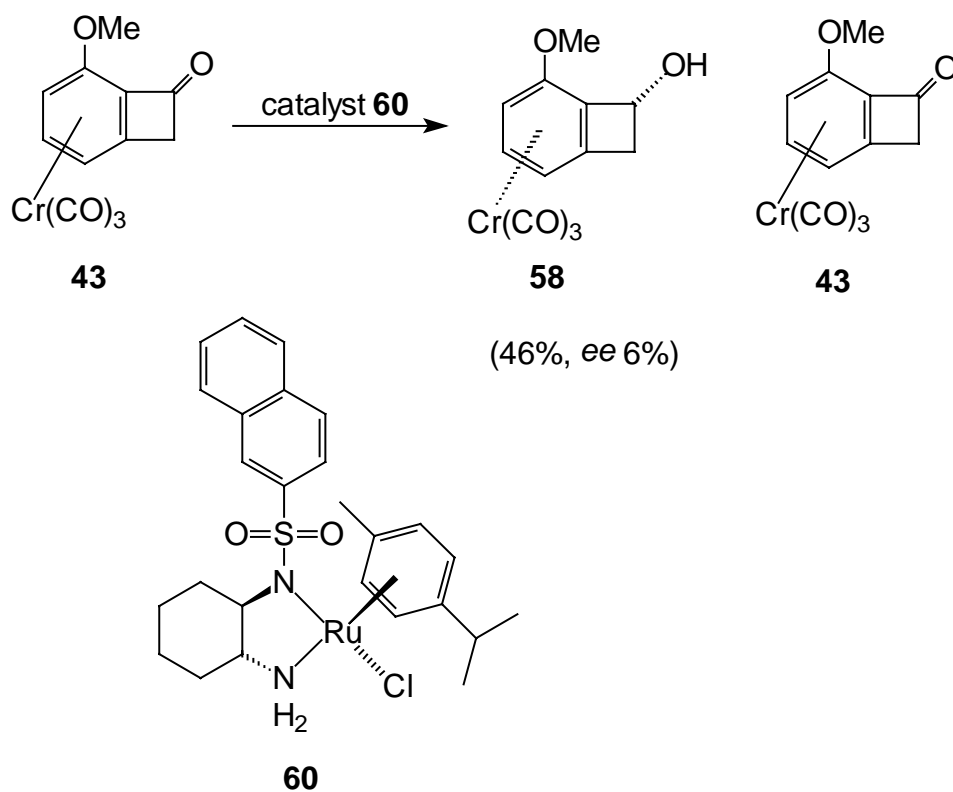

The Grignard reagents can be added to the complex **43** diastereoselectively from the face opposite to the chromium moiety in high yield at low temperature. However, upon addition of alkyllithium to the methoxy substituted

benzocyclobutenone complex **43** at low temperature ( $-78\text{ }^{\circ}\text{C}$ ), the expected addition products were not observed. Instead, only proximal ring opening products were obtained. This indicates that in contrast to the unsubstituted analogue the negative charge is significantly stabilized at the position *ortho* to methoxy group of the 6-methoxybenzocyclobutenone complex **43**, so that a proximal ring opening in the cyclobutene ring is favored over the distal ring opening. The 1-*endo*-hydroxy-1-*exo*-vinyl-6-methoxybenzocyclobutene complex (**63**) underwent an anion driven rearrangement giving the complex **67** upon treatment with butyl lithium at  $-78\text{ }^{\circ}\text{C}$ . So far, such anion driven rearrangements are rare. A similar type of rearrangement was also found in the case of the addition of lithiated methoxyallene to the unsubstituted benzocyclobutenone complex **32**.<sup>71</sup>

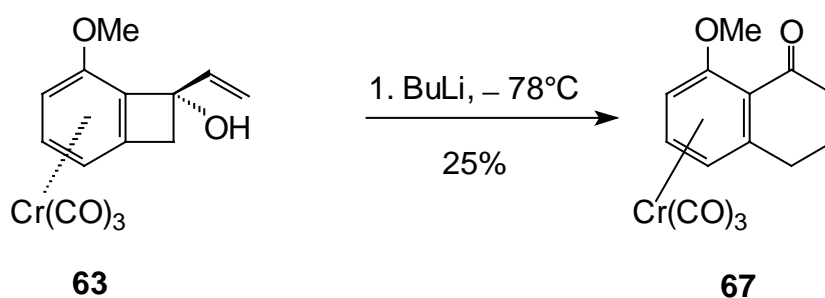

When complex **43** was treated with two equivalents of alkyl lithium at  $-78\text{ }^{\circ}\text{C}$ , a proximal ring opening followed by the formation of diadducts **74** and **75** in high yield were observed. Treatment of **74** with acid caused an elimination of water to the complex **76** in high yield.

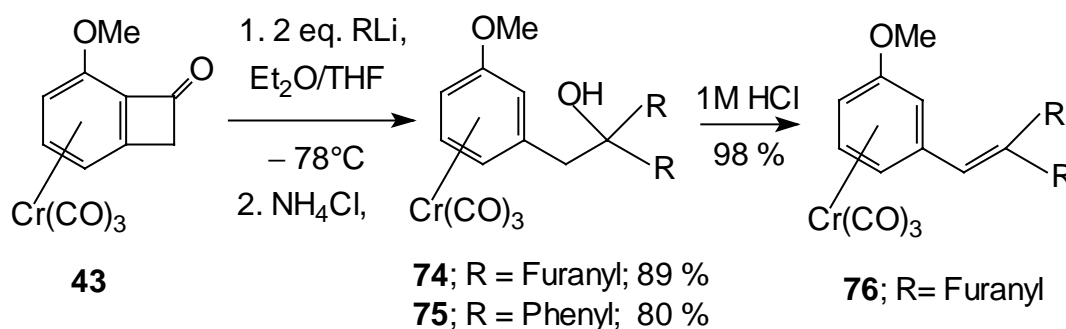

When 1-*endo*-hydroxy-6-methoxybenzocyclobutene complex (**58**) was treated with the 1 equivalent of butyllithium at  $-78^{\circ}\text{C}$ , deprotonation of the alcohol took place. The alcoholate underwent an anion driven distal ring opening to an *ortho*-quinodimethane intermediate. This *ortho*-quinodimethane undergoes [4+2] cycloaddition reactions in the presence of methyl acrylate to form complexes **88** and **89** in 3:1 ratio in 80 % yield.

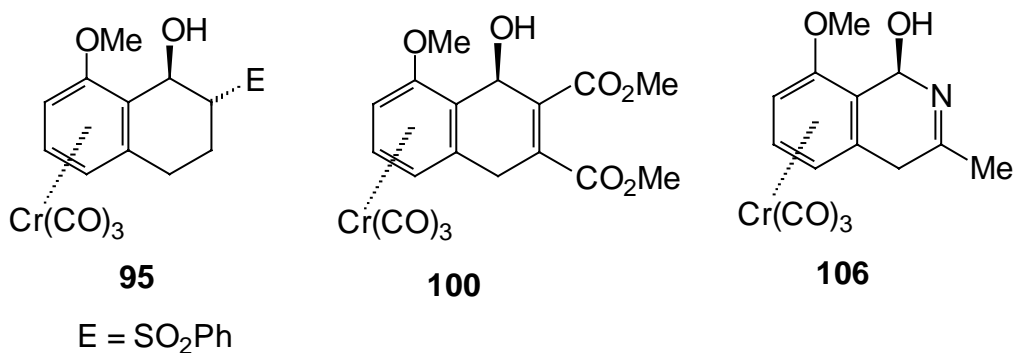
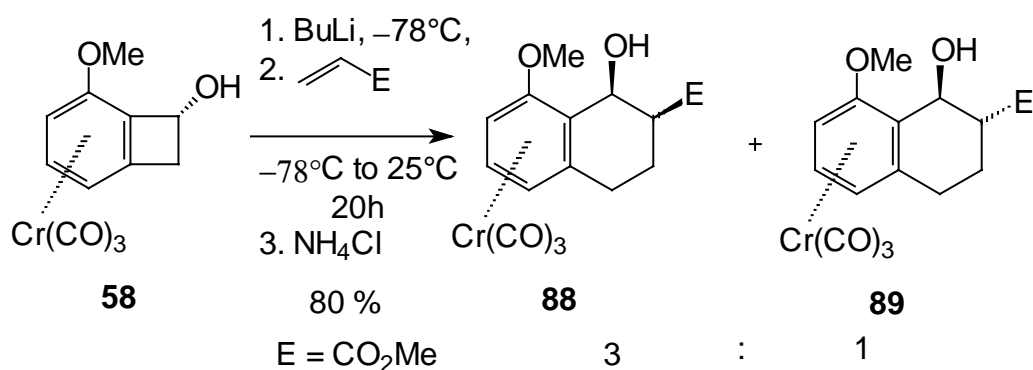

The relative configuration of such a [4+2] cycloadduct with vinyl sulfone **95** was opposite to the relative configuration of the main product from methyl acrylate **88**. A corresponding result was obtained in the case of the unsubstituted complex.<sup>20, 42,43</sup> The [4+2] cycloaddition of **58** with dimethyl butynedioate results in the complex **100** in 62% yield, which could generate a naphthalene system after elimination of water. A [4+2] cycloaddition can also be performed with acetonitril as the dienophile in a hetero Diel's Alder cycloaddition. When **58** was deprotonated with butyllithium followed by addition of acetonitril, complex **106**

was obtained 84 % yield. This could be transformed to the isoquinoline system after elimination of water.

An intramolecular cycloaddition approach was used for attempts directed to the synthesis of some steroid systems,<sup>85</sup> starting from the complex **64**. However, in many attempts, such an intramolecular cycloaddition failed and only a proximal ring opening product **105** was obtained 60 % yield.<sup>44</sup>

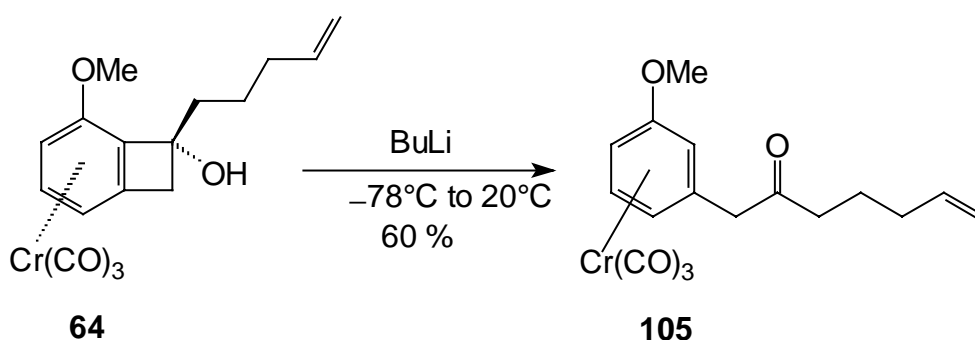

So far the chemistry of the methoxy substituted benzocyclobutenone complex **43** and unsubstituted benzocyclobutenone complex **32** are not significantly different. However, it is interesting to explore the chemistry of methoxy substituted benzocyclobutenedione complex **42** since in comparison to the unsubstituted complex its symmetry is reduced by introduction of the methoxy group at the aromatic ring. When the complex **42** was reduced with an equivalent of lithium aluminium hydride, a mixture of **123** (44% yield) and **124** (40% yield) was obtained in approximately 1:1 ratio indicating increased reactivity at C-1 as compared to C-2.

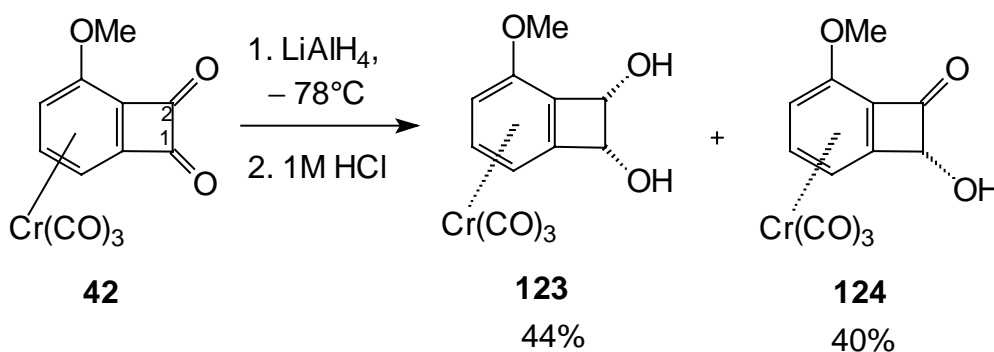

The complex **42** was treated with one equivalent of vinylmagnesium bromide, mono adducts **126** and **127** were obtained in 3:1 ratio. Similarly, when the bisacetal complex was hydrolyzed with 50% HCl, the mono acetal **125** was obtained (35% yield) along with diketone complex **42**.

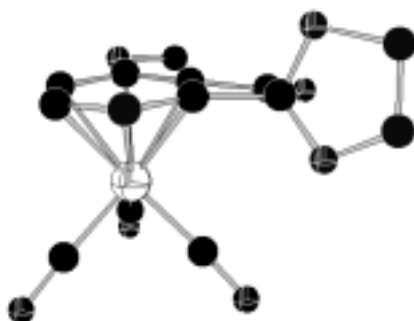
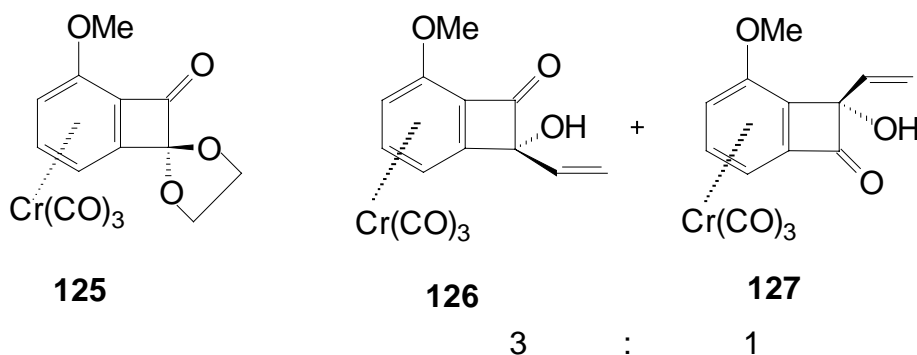
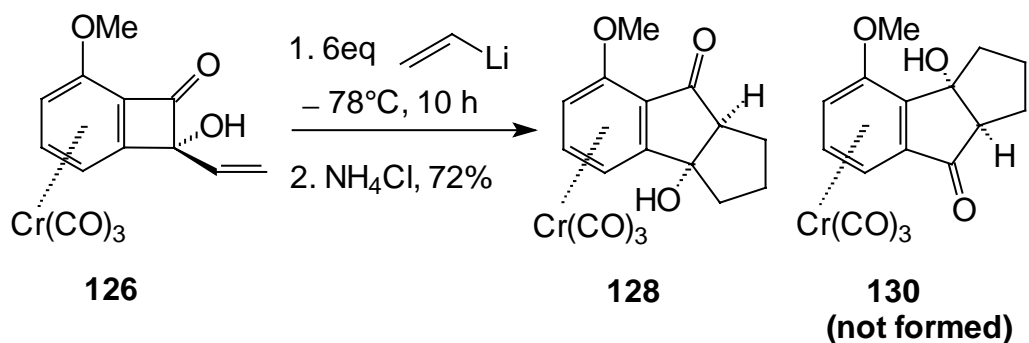

Fig.7: Structure of **125** in the crystal

These results indicated that the carbonyl (C-1) which is further away from the methoxy group was more reactive for nucleophilic addition than the carbonyl group (C-2) near to methoxy group.

The *2-endo*-hydroxy-*2-exo*-vinyl-6-methoxybezocycobutenone complex (**126**) was used for the dianionic oxy-Cope rearrangement followed by an intramolecular aldol addition. When the complex **126** was treated with a variety of alkenyllithium reagents, a dianionic oxy-Cope rearrangement followed by an intramolecular aldol

addition takes place selectively to form only one product among the two possible products. For example, treatment of vinyl lithium with **126** gave only product **128** in 72% yield and another possible intramolecular aldol adduct **130** was not observed.



The mechanism of this selective aldol addition could be explained as follows:

The vinyl lithium added to the complex **126** from the face opposite to the bulky chromium carbonyl moiety resulting in the *syn* or *cis* addition to complex **126**. The double vinyl *cis* addition favors the dianionic oxy-Cope rearrangement resulting in the benzocyclooctadienolate intermediate **129**. This intermediate could lead to two other intermediates **129a** and **129b** after single protonation. These two intermediates **129a** and **129b** can undergo an intramolecular aldol addition giving the products **128** and **130**, respectively. However, in the above reaction only the product **128** was obtained in good yield. This indicates selective formation of the intermediate **129a** at the protonation step so that an intramolecular aldol addition gives the product **128**. Formation of that intermediate **129a** is favored over the intermediate **129b** could be due to the effect of the methoxy group present in the intermediate **129**. This methoxy group can effect in two ways either by pushing electron density to enolate-1 or, more likely, by chelation of the lithium counter ion of enolate-1 in **129**.

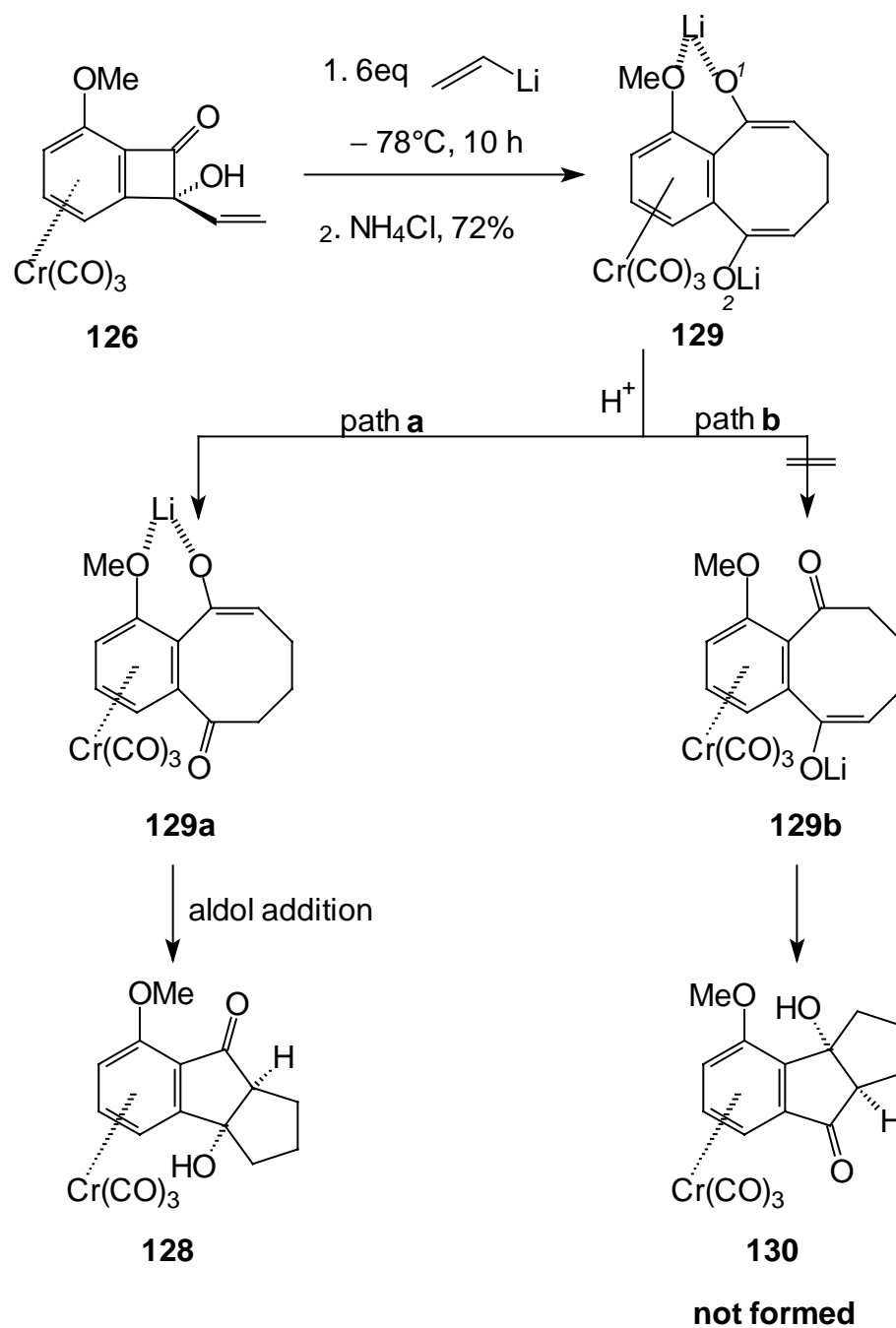

Similar results were also observed when **126** was treated with cyclopentenyllithium and propenyllithium resulting **135** and **141** in 62 % and 76% yields respectively.



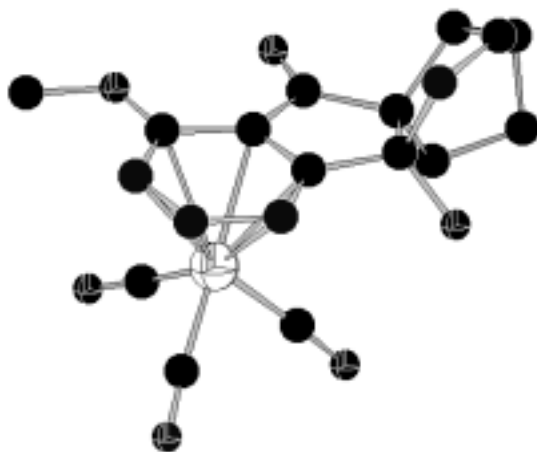

Fig.9: Structure of **135** in the crystal

However, in these cases the two nucleophiles finally added to **42** were different, and it was not clear, which are the factor for the selectivity, either the methoxy group or the nature of nucleophile used for a dianionic oxy-Cope rearrangement. Therefore, it was thought to use same nucleophile for the dianionic oxy-Cope rearrangement followed by an intramolecular aldol addition with 3-methoxybenzocyclobutenedione complex **42**. The complex **42** was treated with different nucleophiles e.g. vinylolithium, 2-propenyllithium, 1-cyclopentenyllithium, 1-lithio methoxyallene, and 1-ethoxyethenyllithium, resulting complexes **128**, **143**, **145**, **147** and **149** in 72 %, 74 %, 67 %, 59 % and

89% respectively. The relative configuration of complex **149** was confirmed from its X-ray structure.

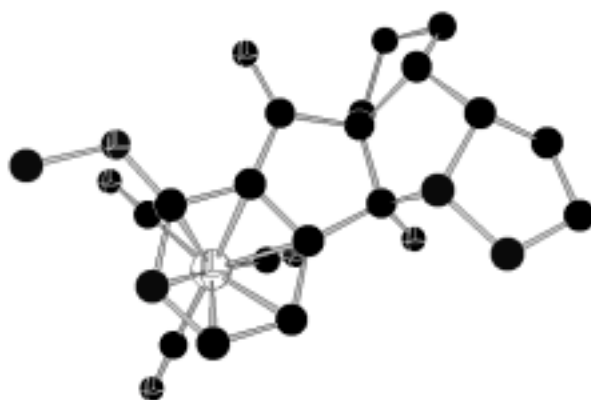
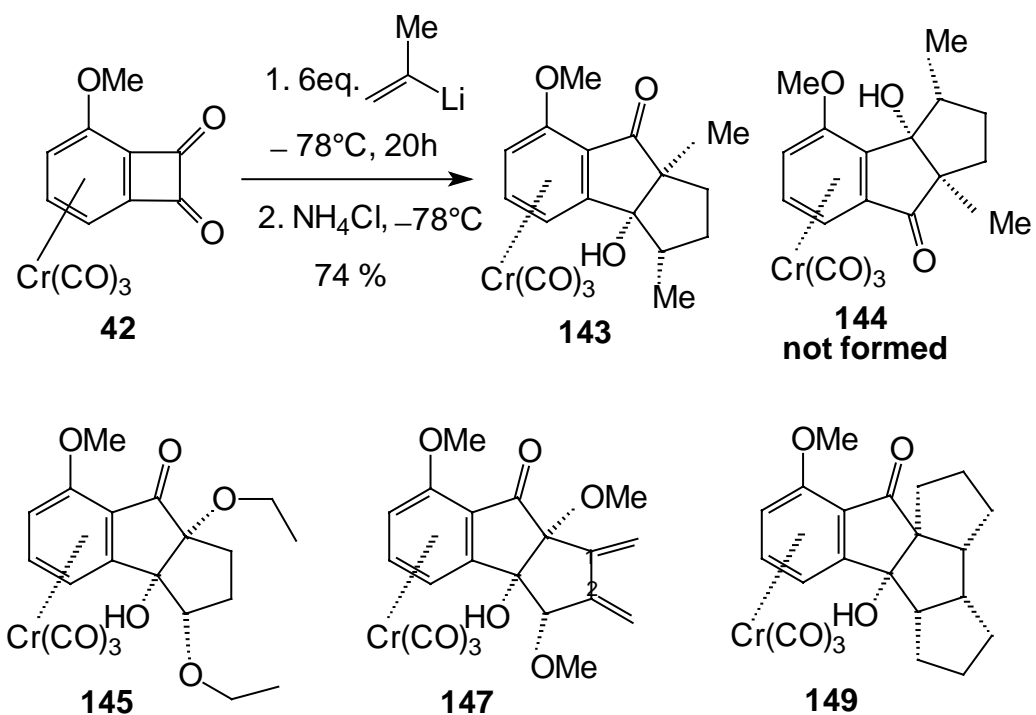
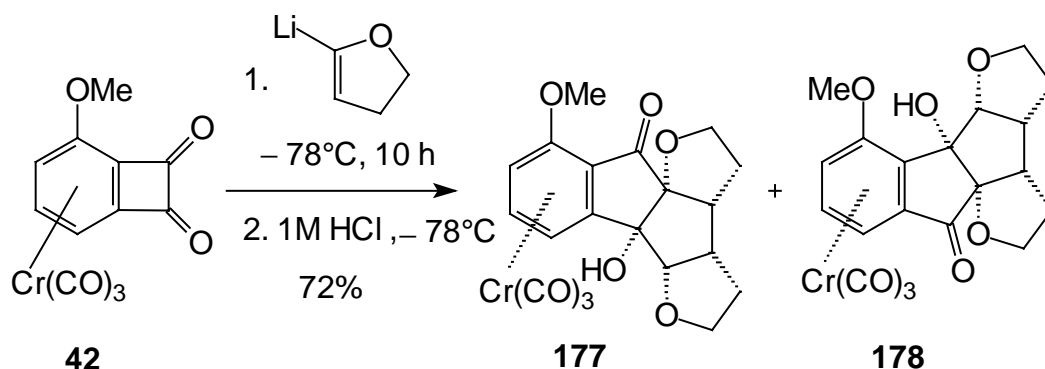

Fig.12: Structure of **149** in the crystal

The result indicated that methoxy group at aromatic ring plays an important role for the selective aldol adduct either differing electron densities in two enolates or

the chelation with enolates, favoring the above mentioned products over the next possible products.

In contrast, treatment of **42** with the 1-lithio 2,3-dihydrofuran at  $-78\text{ }^{\circ}\text{C}$ , two regioisomers **177** and **178** were obtained in 1:1 mixture in 72% yield.



The two products could be explained due the potential of chelation with both enolates and hetero atoms by the lithium ions. This also indicates that the chelation effect plays significant role in the selectivity of protonation following the selective intramolecular aldol addition.

Upon treatment of **42** with lithio-3,4-dihydro-2H-pyran, an unexpected product **159** was obtained in 60 % yield, which could be the result of anion driven rearrangement.

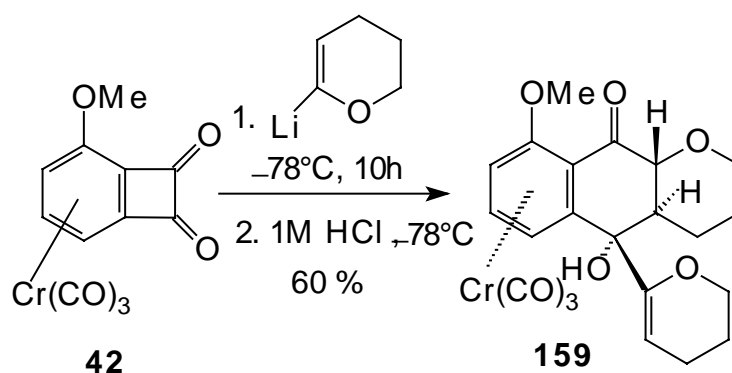

The configuration of **159** was later confirmed from its X-ray structure.

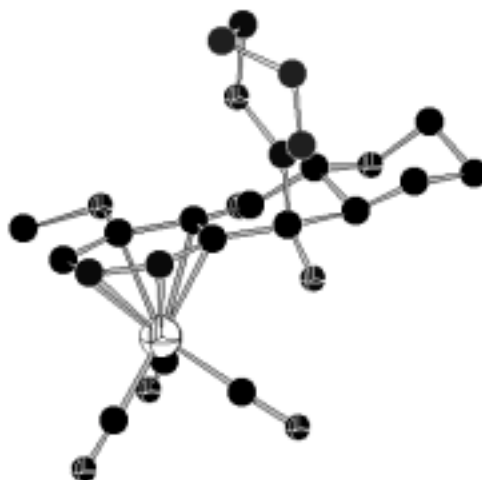
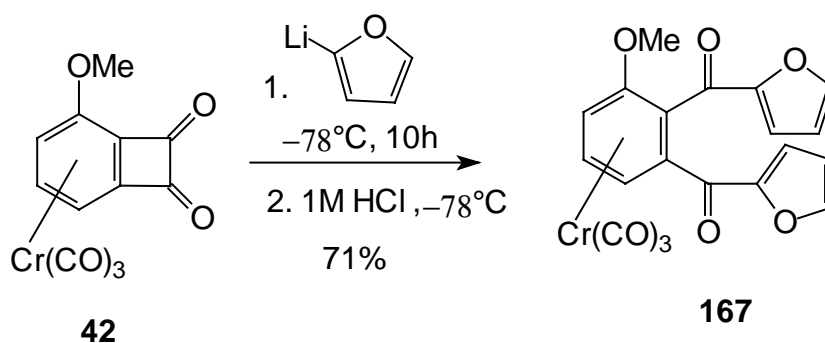

Fig.13: Structure of **159** in the crystal

Such anion driven 1-vinylcyclobutenol-cyclohexadiene rearrangements are rare.<sup>116</sup> In the similar condition, the addition of other nucleophiles results in dianionic oxy-Cope rearrangement followed by aldol addition. The cause of this reaction is so far unclear.

When complex **42** was treated with furanyllithium no rearrangement product was obtained and instead distal ring opening product **167** was obtained in 71% yield. A similar result was also obtained in the case of the unsubstituted complex.<sup>114</sup>



Trifluoromethyl substituted benzocyclobutenone **173** and trifluoromethyl substituted benzocyclobutenedione **175** were prepared by using the same approach

for syntheses of methoxy substituted benzocyclobutenone and benzocyclobutenedione.<sup>52,57</sup> These compounds are new and interesting since they contain electron withdrawing trifluoromethyl group at the aromatic ring.

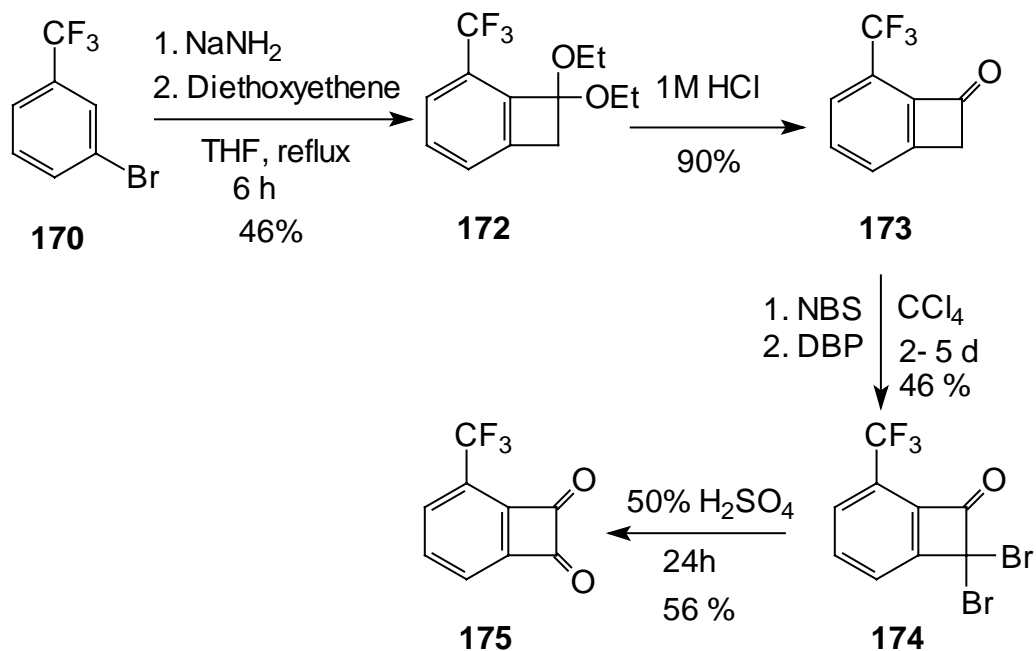

The complexation of 6-trifluoromethylbenzocyclobutenone **173** and 3-trifluoromethylbenzocyclo-butendione **175** were performed by using the similar approach used for the methoxy substituted complexes.<sup>61a, 61b, 62a</sup> The 6-trifluoromethylbenzocyclobutenone **168** was synthesized successfully and was also characterized by X-ray structure analysis.

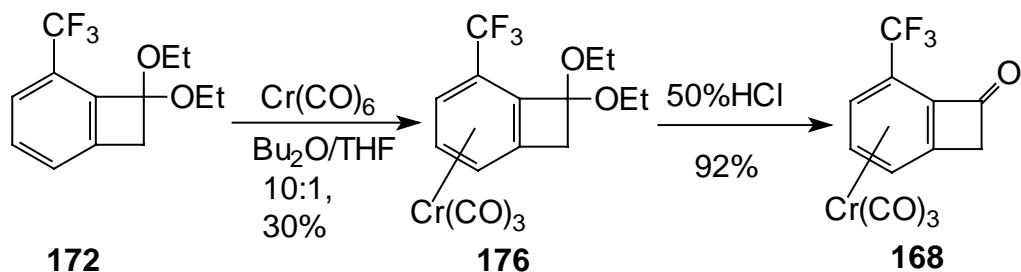

Interestingly the four membered ring of the complex **168** is bent towards the chromium side from aromatic plane by  $4^\circ$ . This indicates the strong electron withdrawing ability of trifluoromethyl and chromium moiety.

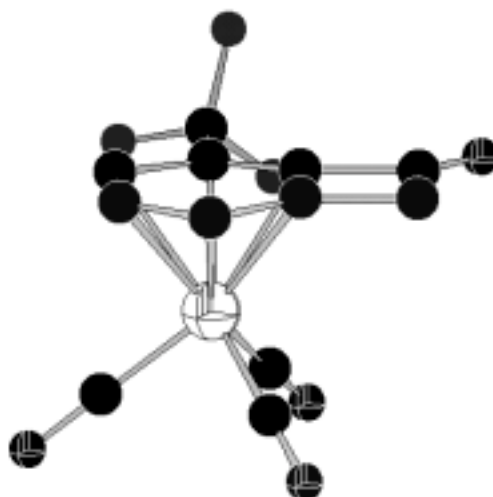
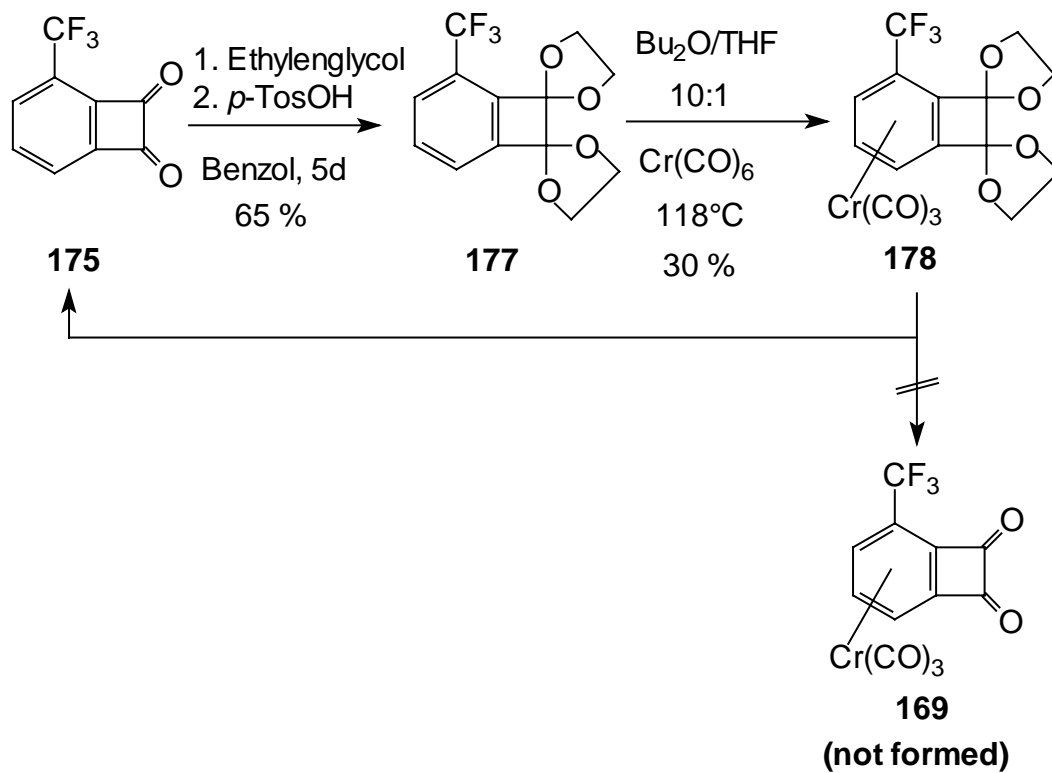

Fig.14: Structure of **168** in the crystal

Unfortunately, the complex **169** could not be synthesized and in several trials only the ligand of it was obtained after hydrolysis of corresponding bisacetal complex. The complexation of the bisacetal was also found difficult and even during the purification of the bisacetal, decomplexation was observed. However, by using the mild hydrolysis agents it could be possible to synthesize the trifluoromethyl substituted benzocyclobutenedione complex **169** from corresponding bisacetal complex. So far the chemistry of unsubstituted and methoxy substituted benzocyclobutenone and benzocyclobutenedione complex have been explored therefore it is interesting to investigate the effect of the trifluoromethyl group.



## D Experimental Section

### 9 General

All operations were performed in flame-dried reaction vessels in an argon atmosphere using the Schlenk technique. Diethyl ether, dibutyl ether and THF were distilled from sodium-potassium alloy/benzophenone. Ethanol was dried with sodium. Pentane, dichloromethane and carbon tetrachloride were dried with calcium hydride. Petroleum ether, *tert*-Butylmethyl ether (TBME) were dried with calcium chloride. All the solvents were argonated before used.

Preparative column chromatography was carried out using the flash chromatography principle.<sup>118</sup> Silica gel used was from the J. T. Baker with particle size 40  $\mu\text{m}$ . The silica gel was degassed by heating it with a flame at reduced pressure followed by setting it under normal pressure with argon. This was repeated five to six times; then it was put under high vacuum for 24 h and then argonated. All the solvents used for the column were first distilled over drying agents e.g. calcium chloride, sodium sulfate and then argoned for about 20 min by passing constant argon stream.

Thin layer chromatography (TLC) was carried out using aluminum TLC plate coated with the silica gel 60F<sub>254</sub> from Merck combined with the polygram<sup>®</sup> Alox N/UV<sub>254</sub> from Macherey-Nagel. The detection of changed substances over the TLC was done with the help of the UV-lamp ( $\lambda = 254 \text{ nm}$ ) and developed in Ce(IV) sulfate reagent.<sup>119</sup>

#### 9.1 Analytical Methods

*IR-Spectra* were obtained using the spectrometer Perkin-Elmer FT 1710. The following abbreviations were used to indicate the intensity of the absorption bands: s = strong, m = middle, w = weak.



**Mass spectrometry (MS)** was carried out using a Finnegan AM 400 mass spectrometer (Ionization potential 70 eV). **FAB-MS spectra** were carried out using a VG-Autospec spectrometer in a low resolution measurement with a nitrobenzyl alcohol matrix (NBA-Matrix). **HR-FAB MS** was carried out using a VG-Autospec spectrometer with the peak-matching method (PFK), and the NBA-Matrix was used.

**<sup>1</sup>H NMR spectra** were measured using the instrument Bruker WP 200 (200.1 MHz), 400 (400 MHz) and AVS 400 (400.1 MHz). In the case where no tetramethylsilane (TMS,  $\delta = 0.00$ ) was used as a reference, a solvent peak was used as a reference.<sup>120</sup> The multiplicity of the peaks were abbreviated as s = singlet, d = doublet, t = triplet, q = quartet, m = multiplet, br = broad.

**<sup>13</sup>C NMR- spectra** were measured using the instrument Bruker AVS 200 (50.3 MHz) and AVS 400 (100.6 MHz). In cases where no TMS used as a reference, the solvent peak was used as a reference.<sup>120</sup> The multiplicity of the signals was determined with ATP and DEPT techniques. Signals (peaks) with negative phase for CH and CH<sub>3</sub> were labeled with " - ", and those with positive phase for C and CH<sub>2</sub> were labeled with " + ".

Air sensitive samples prepared under argon using the Schlenk technique. The deuterated solvents were stored under argon. [D<sub>6</sub>]-acetone, and CDCl<sub>3</sub> were stored over molecular sieve (3Å), [D<sub>6</sub>]-benzol, [D<sub>6</sub>]-THF were stored over sodium/potassium under argon.

**Melting points** were measured by using a Büchi apparaur according to Dr. Tottoli without any correction.

**Elemental analyses** were carried out for CHN with a Häraeus instrument.

**Preparation of different reagents** were carried out using the following references: Methoxyallen,<sup>121</sup> Phenyllithium,<sup>122</sup> Vinylithium,<sup>123</sup> Vinylmagnesiumbromide.<sup>117,124,</sup>

**General Remark:** The atom numbering of the molecule is arbitrary, however, the naming of the molecules is according to the IUPAC system. The lithium sand used contains 2 % of sodium.

### 10.1 Crystallization of 3-Methoxybenzocyclobutenedione complex **42**

The complex **42**<sup>61</sup> was crystallized from the dichloromethane and diethylether.

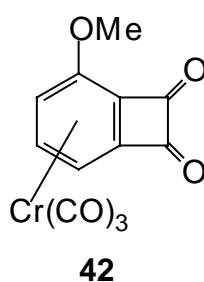

#### Crystal Structure Analysis of **42**:

$C_{12}H_6CrO_6$ , molecular weight, 298.17: crystal system monoclinic. Space group P 21/n (no. 14),  $a = 8.475(1)$ ,  $b = 7.946(1)$ ,  $c = 17.616(3)$  Å,  $\alpha = 90$ ,  $\beta = 95.63(2)$ ,  $\gamma = 90^\circ$ ,  $V = 1180.6(3)$  Å<sup>3</sup>,  $Z = 4$ ,  $d_{\text{calcd.}} = 1.678$  gcm<sup>-3</sup>,  $F(000) = 600e$ ,  $\mu = 9.9$  cm<sup>-1</sup>, crystal: red-brown prism | | (010), size 0.15 × 0.67 × 0.11 mm, Stoe IPDS (Imaging Plate) diffractometer,  $T = 300$  K,  $MoK_\alpha = 0.71073$  Å,  $2\theta_{\text{min}} = 4.6^\circ$ ,  $2\theta_{\text{max}} = 48.1^\circ$ , scan type 160 exposure,  $\Delta\Phi = 1.4^\circ$ , 8555 measured reflections ( $\pm 9$ ,  $\pm 8$ ,  $\pm 20$ ), 1847 independent [ $R(I)_{\text{int}} = 0.039$ ] and 1321 observed reflection [ $I_t > 2.0 \sigma(I)$ ], completeness of data: 99 %, no absorption correction, no extinction correction, structure solution with direct methods with SHELXS-86, refinement with SHELXL-93, hydrogen atoms in geometrically calculated positions,  $N_{\text{ref}} = 1847$ ,  $N_{\text{par}} = 172$ ,  $R = 0.0288$ ,  $R_w = 0.0646$  [ $w = 1/\sigma^2(F_o^2)$ ],  $S = 1.04$ , minimal and maximal residual electron density – 0.23/0.24 eÅ<sup>-3</sup>.

## 10.2 Crystallization of 6-Methoxycyclobutenone complex 43

The complex **43**<sup>61</sup> was crystallized from the diethyl ether and pentane.

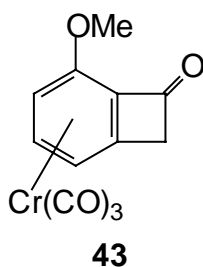

### Crystal Structure Analysis of 43:

$C_{12}H_8CrO_5$ , molecular weight, 284.19: crystal system orthorhombic. Space group P 21/n (no. 19),  $a = 7.917(1)$ ,  $b = 9.096(1)$ ,  $c = 16.203(2)$  Å,  $\alpha = 90$ ,  $\beta = 90$ ,  $\gamma = 90^\circ$ ,  $V = 1166.8(2)$  Å<sup>3</sup>,  $Z = 4$ ,  $d_{\text{calcd.}} = 1.618$  gcm<sup>-3</sup>,  $F(000) = 576e$ ,  $\mu = 9.9$  cm<sup>-1</sup>, crystal: red rod | | (100), size 0.67 × 0.18 × 0.12 mm, Stoe IPDS (Imaging Plate) diffractometer,  $T = 300$  K,  $MoK_\alpha = 0.71073$  Å,  $2\theta_{\text{min}} = 5.0^\circ$ ,  $2\theta_{\text{max}} = 56.5^\circ$ , scan type 220 exposure,  $\Delta\Phi = 1.5^\circ$ , 16334 measured reflections ( $\pm 10$ ,  $-11$ ,  $+12$ ,  $\pm 21$ ), 2840 independent [ $R(I)_{\text{int}} = 0.062$ ] and 2329 observed reflection [ $I_t > 2.0 \sigma(I)$ ], completeness of data: 100 %, no absorption correction, no extinction correction, structure solution with direct methods with SHELXS-86, refinement with SHELXL-93, hydrogen atoms in geometrically calculated positions,  $N_{\text{ref}} = 2840$ ,  $N_{\text{par}} = 163$ ,  $R = 0.0304$ ,  $R_w = 0.0618$  [ $w = 1/\sigma^2 (F_o^2)$ ],  $S = 1.22$ , minimal and maximal residual electron density – 0.33/0.33 eÅ<sup>-3</sup>.

**11 Tricarbonyl- $\eta^6$ - (1-endo-hydroxy-6-methoxybezocyclobutene) chromium (0)**

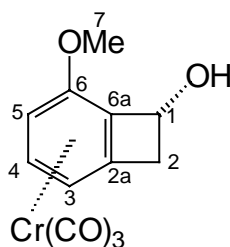

**58**

A solution of 2.0 g (7.0 mmol) of **43** in 100 mL of diethyl ether was slowly added dropwise to a  $-78^{\circ}\text{C}$  cold mixture of 89 mg (2.3 mmol) of lithiumtetrahydridoaluminate in 10 mL of diethyl ether. After the addition, the color immediately changed from orange to light yellow. The mixture was stirred for about 1.5 hours at  $-78^{\circ}\text{C}$  and then hydrolyzed with 20 mL of 1M HCl. The reaction mixture was warmed to  $20^{\circ}\text{C}$  and extracted with TBME till the aqueous layer was colorless. The collected organic layers were washed two times with the 50 mL of water. The extracted organic solvent was dried with  $\text{MgSO}_4$ , filtration and evaporation of the solvent at reduced pressure. The crude yellow solid was purified by column chromatography (200  $\times$  20 mm,  $\text{SiO}_2$ , eluted first PE, then TBME/PE, 2:1). 1.82 g (6.33 mmol, 98%) of Tricarbonyl- $\eta^6$ - (1-endo-hydroxy-6-methoxybezocyclobutene) chromium (0) (**58**) was obtained as a yellow solid (m. p.  $108.5^{\circ}\text{C}$ ).

**58:** IR ( $\text{CHCl}_3$ ):  $\tilde{\nu} = 3556\text{ cm}^{-1}$  (br, OH), 2944 (w), 1968 (s, CO), 1892 (s, CO), 1536 (w), 1460 (m), 1424 (m), 1276 (m), 1048 (m). -  $^1\text{H}$  NMR (400.1 MHz, acetone- $d_6$ ):  $\delta = 2.18$  (s, 1H, OH), 3.15 (d, 1H, 2-endo-H,  $^2J_{2\text{-endo}, 2\text{-exo}} = -12.0$  Hz,  $^3J_{2\text{-endo}, 1\text{-exo}} = 2.2$  Hz, 2-H), 3.58 (dd, 1H, 2-exo-H,  $^3J_{2\text{-exo}, 1\text{-exo}} = 5.4$  Hz, 2-H), 3.94 (s, 3H,  $\text{OCH}_3$ ), 4.82 (d, 1H,  $^3J = 6.8$  Hz, 3-H), 4.91 (d, 1H,  $^3J = 6.0$  Hz, 4-H), 5.23 (dd, 1H, 1-H), 5.26 (t, 1H,  $^3J = 6.4$  Hz,  $^3J = 6.4$  Hz, 5-H). -  $^{13}\text{C}$  NMR (100.6 MHz,  $\text{CDCl}_3$ , APT):  $\delta = 43.2$  (+, C-2), 58.8 (-, C-7), 69.9 (-,

C-1), 76.9 (–, C-3), 82.1 (–, C-4), 97.0 (–, C-5), 105.0 (+, C-2a), 115.1 (+, C-6a), 141.8 (+, C-6), 233.8 (+, CO). - MS (70 eV, 70 °C):  $m/z$  (%) = 286 (26)  $[M^+]$ , 258 (2)  $[M^+ - CO]$ , 230 (11)  $[M^+ - 2CO]$ , 202 (89)  $[M^+ - 3CO]$ , 187 (26), 150 (6), 52 (100)  $[Cr^+]$ . - HRMS  $C_{12}H_{10}CrO_5$  (286.2): Calcd: 285.993333; found. 285.993164: calcd. C 50.36, H 3.50; found. C 50.07, H 3.66.

## 12 General Method for Grignard Addition to Complex **43** (GP I)

The 6-methoxybenzocyclobutenone complex **43** is dissolved in diethyl ether ( $Et_2O$ ) and is cooled  $-78^\circ C$ . The solution is stirred at  $-78^\circ C$  for about 20 min and the Grignard reagent is added to the reaction mixture at  $-78^\circ C$ . The solution is stirred for 4 hours and then hydrolyzed with 20 mL 1 M hydrochloric acid at  $-78^\circ C$ . After warming to  $20^\circ C$ , the reaction mixture is extracted with TBME till the aqueous layer is colorless. The extracted organic solvent is washed with water two times, then dried over  $MgSO_4$ . The solvent is filtered through a celite or silica gel filled P4-frit and washed celite or silica gel with solvent till it remain colorless. The solvent is evaporated at reduced pressure. The crude product is purified by column chromatography ( $200 \times 20$  mm,  $SiO_2$ ), with TBME/PE.

### 12.1 Tricarbonyl ( $\eta^6$ -1-*endo*-hydroxy-1-*exo*-methyl-6-methoxybenzo-cyclobutene)chromium (0) (**62**)

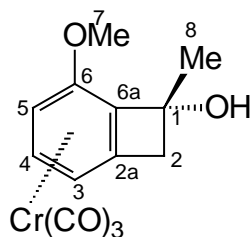

**62**

**GP I**, 250 mg (0.833 mmol) of **43** in 35 mL of diethyl ether was added to 1.05 mL (1.17 mmol) of a 0.9 M solution of methyl magnesium bromide in diethyl ether. After stirring 10 h at  $-78^{\circ}\text{C}$ , hydrolysis with 20 mL 1M HCl at  $-78^{\circ}\text{C}$ . a crude product was purified by column chromatography (200  $\times$  20 mm, SiO<sub>2</sub>, TBME/PE, 2:1), 243 mg (0.8 mmol, 98%) **62** was obtained as yellow crystals (m. p.  $114^{\circ}\text{C}$ ).

**62**: IR: (ATR):  $\tilde{\nu}$  = 3568 (w, OH)  $\text{cm}^{-1}$ , 2941 (m), 1944 (s, CO), 1870 (s CO), 1834 (s), 1605 (w), 535 (m), 1508 (m), 1459 (m), 1274 (s), 1164 (w), 1056 (s), 841(w), 670 (m). -  $^1\text{H}$  NMR (400.1 MHz,  $\text{CDCl}_3$ ):  $\delta$  = 1.76 (s, 3H,  $\text{OCH}_3$ ), 3.27 (s, 2H, 2-H), 3.95 (3H,  $\text{OCH}_3$ ), 4.66 (s, br, 1H, OH), 5.06 (d, 1H,  $^3J$  = 6.9 Hz, 3-H), 5.18 (d, 1H,  $^3J$  = 6.0 Hz, 5-H), 5.73 (dd, 1H,  $^3J$  = 6.4 Hz, 4-H). -  $^{13}\text{C}$ -NMR (100.6 MHz,  $\text{CDCl}_3$ , APT):  $\delta$  = 26.5 (–, C-8), 46.7 (+, C-2), 57.1(–, C-7), 75.4 (+, C-1), 76.3 (–, C-3), 82.2 (–, C-4), 96.2 (–, C-5), 109.0 (+, C-2a), 114.0 (+, C-6a), 140.1 (+, C-6), 233.5 (+, CO). - MS (70eV,  $145^{\circ}\text{C}$ ):  $m/z$  (%) = 300 (38) [ $\text{M}^+$ ], 244 (10)[ $\text{M} - 2 \text{CO}$ ], 216 (100) [ $\text{M} - 3\text{CO}$ ], 198 (31), 181 (4), 164 (13), 147 (37), 121 (12), 91 (16), 77 (7), 52 (71) [Cr]. - HRMS ( $\text{C}_{13}\text{H}_{12}\text{CrO}_5$ ): Calcd: 300.007721; found: 300.008983. Calcd: C 52.05, H 4.06; Found: C 52.42, H 4.13.

## 12.2 Tricarbonyl( $\eta^6$ - 1- *endo*-hydroxy-1-*exo*-vinyl-6-methoxybenzo-cyclobutene)chromium (0) (**63**)

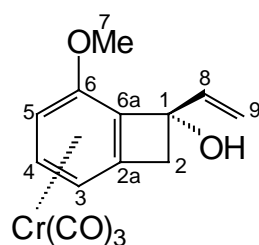

**63**

**GP I**, 250 mg (0.83 mmol) of **43** in 35 mL of diethyl ether added to 0.9 mL (1.08 mmol) of 0.9 M vinylmagnesiumbromide<sup>117,124</sup> in diethyl ether, stirred 10 h at  $-78^{\circ}\text{C}$ , hydrolyzed with 1M HCl at  $-78^{\circ}\text{C}$ . After work up, a yellow crude product was obtained. Purified by column chromatography (200 × 20 mm, SiO<sub>2</sub>, TBME/PE, 2:1), 239 mg (0.77 mmol, 96%) of **63** was obtained as a yellow needles (m. p.  $92^{\circ}\text{C}$ ).

**63**: IR: (ATR):  $\tilde{\nu}$  = 3458 (w, OH)  $\text{cm}^{-1}$  2942 (m), 1950 (s, CO), 1852 (s, CO), 1603 (w), 1534 (m), 1462 (m), 1423 (m), 1266 (m), 1150 (w), 1054 (w), 802 (w), 671 (m). <sup>1</sup>H NMR (400.1 MHz, CDCl<sub>3</sub>):  $\delta$  = 3.36 (d, 1H, *endo*-2-H or *exo*-2-H, <sup>2</sup>*J*<sub>*endo*-2H, *exo*-2H</sub> = -15.4 Hz, 2-H), 3.44 (d, 1H, *endo*-2-H or *exo*-2-H, <sup>2</sup>*J*<sub>*endo*-2H, *exo*-2H</sub> = -15.1 Hz, 2-H) 3.87 (3H, OCH<sub>3</sub>), 4.86 (d, 1H, <sup>3</sup>*J* = 6.78 Hz, 3-H), 4.97 (d, 1H, <sup>3</sup>*J* = 5.89 Hz, 5-H), 5.1 (br, 1H, OH), 5.29 (d, 1H, <sup>3</sup>*J*<sub>*cis*</sub> = 10.7 Hz, *Z*-9-H), 5.56 (d, 1H, <sup>3</sup>*J*<sub>*trans*</sub> = 17.2 Hz, *E*-9-H), 5.56 (dd, 1H, <sup>3</sup>*J* = 6.28 Hz, <sup>3</sup>*J* = 6.15 Hz, 4-H), 6.18 (dd, 1H, <sup>3</sup>*J*<sub>*trans*</sub> = 16.9 Hz, <sup>3</sup>*J*<sub>*cis*</sub> = 10.7, 8-H). <sup>13</sup>C NMR (100.6 MHz, CDCl<sub>3</sub>, APT):  $\delta$  = 48.1 (+, C-2), 58.1 (-, C-7), 78.1 (+, C-1), 81.3 (-, C-3), 94.7 (-, C-4), 96.2 (-, C-5), 106.6 (+, C-2a), 113.4 (+, C-9), 114.9 (+, C-6a), 139.2 (-, C-8), 140.7 (+, C-6), 233.5 (+, CO). - MS (70eV, 60°C): *m/z* (%) = 312 (20) [M<sup>+</sup>], 256 (7) [M - 2CO], 228 (49) [M - 3CO], 195 (19) [M - OCH<sub>3</sub>, 2H], 160 (55), 138 (4), 117 (14), 88 (10), 73 (24), 52 (100) [Cr<sup>+</sup>]. - HRMS (C<sub>17</sub>H<sub>18</sub>CrO<sub>5</sub>): calculated: 312.009065; found: 312.008983.

### 12.3 Tricarbonyl( $\eta^6$ - 1- *endo*-hydroxy-1-*exo*-vinyl-6-methoxybenzo-cyclobutene)chromium (0) (**64**)

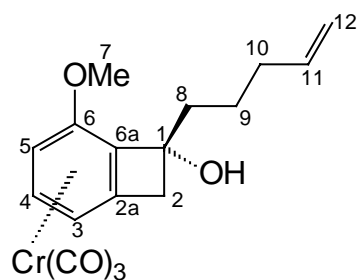

**64**

**GP I**, A solution of 250 mg (0.88 mmol) of **43** in 35 mL diethyl ether was added to 1 ml of 0.9 M pentenyl magnesium bromide<sup>124</sup> in diethyl ether, stirred 10 h in  $-78^{\circ}\text{C}$ , hydrolyzed with 10 mL 1M HCl at  $-78^{\circ}\text{C}$ . After work up, a crude yellow product was obtained, and purified by column chromatography (200  $\times$  20 mm, SiO<sub>2</sub>, TBME/PE, 2:1), 295 mg (0.8 mmol, 95%) of **64** was obtained as an orange-yellow oil.

**64**: IR: (CDCl<sub>3</sub>):  $\tilde{\nu}$  = 3565 (br, OH) cm<sup>-1</sup>, 2940 (m), 1970 (s, CO), 1884 (s), 1639 (w), 1534 (m), 1462 (m), 1230 (s, C-O), 1116 (w), 826 (w). <sup>1</sup>H NMR (400.1 MHz, CDCl<sub>3</sub>):  $\delta$  = 1.47-1.67 (m, 2H, 9-H or 10-H), 1.87- 2.01 (m, 2H, 10-H or 9-H), 2.1 (m, 2H, 8-H), 2.40 (s, OH), 3.18 (d, 1H, *exo*-2-H or *endo*-2-H, <sup>2</sup>*J*<sub>*exo*-2, *endo*-2</sub> = -14.4 Hz, 2-H), 3.31 (d, 1H, *exo*-2-Hz or *endo*-2-H, <sup>2</sup>*J*<sub>*exo*-2, *endo*-2</sub> = -14.4 Hz, 2-H), 3.38 (3H, OCH<sub>3</sub>), 4.8 (d, 1H, <sup>3</sup>*J* = 6.8 Hz, 3-H), 4.95 (d, 1H, <sup>3</sup>*J* = 6.0 Hz, 5-H), 5.04 (d, 2H, <sup>3</sup>*J*<sub>*trans*</sub> = 21.1 Hz, 12-H), 5.53 (t, 1H, <sup>3</sup>*J* = 6.4 Hz, <sup>3</sup>*J* = 6.3 Hz, 4-H), 5.7 (m, 1H, 11-H). -<sup>13</sup>C NMR (100.6 MHz, CDCl<sub>3</sub>, APT):  $\delta$  = 24.6 (+, C-8), 33.9 (+, C-9), 38.2 (+, C-10), 46.0 (+, C-2), 57.0 (-, C-7), 75.6 (-, C-3), 97.6 (+, C-1), 82.1 (-, C-4), 96.5 (-, C-5), 109.5 (+, C-2a), 114.0 (+, C-12), 115.4 (+, C-6a), 138.5 (-, C-11), 140.9 (+, C-6), 233.5 (+, CO). - MS (70eV, 50°C): *m/z* (%) = 354 (2)[M<sup>+</sup>], 270 (3) [M - 3CO], 244 (2), 218 (5), 177 (31), 149 (100) [M- Cr(CO)<sub>3</sub> C<sub>5</sub>H<sub>9</sub>], 121 (5), 91 (13), 77 (6), 55 (10), 52 (5) [Cr]. - HRMS (C<sub>17</sub>H<sub>18</sub>CrO<sub>5</sub>): calcd.: 354.05593; found: 354.05593.

**13 Tricarbonyl( $\eta^6$ - 2,3,4, trihydro-8-methoxy-1-naphthenone)-chromium (0) (67)**

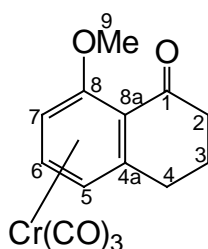

**67**



0.8 mL of a vinyl lithium solution (0.9 M) in 10 ml diethyl ether was slowly added dropwise to a  $-78^{\circ}\text{C}$  cold solution of 200 mg (6.99 mmol) of complex **43** in 100 ml of THF. After addition of vinyl lithium<sup>123</sup>, the color of the reaction solution changed immediately from orange to yellow. The reaction mixture was warmed to  $20^{\circ}\text{C}$  over night, and hydrolyzed with a saturated ammonium chloride solution at  $-78^{\circ}\text{C}$ . After warming to  $20^{\circ}\text{C}$ , it was extracted three times with 30 mL TBME till the aqueous layer remained colorless. The collected organic layers were washed with water two times. The extracted organic layers were dried over  $\text{MgSO}_4$ , filtered, and the solvent was evaporated into a cold trap. The crude yellow solid was purified by column chromatography ( $200 \times 20$  mm,  $\text{SiO}_2$ , TBME/PE, 2:1). 58 mg (0.2 mmol, 25%) of **67** was obtained as a yellow (m. p.  $114.4^{\circ}\text{C}$ ).

**67**: IR: (ATR):  $\tilde{\nu} = 2942$  (m)  $\text{cm}^{-1}$ , 1972 (s, CO), 1890 (s, CO), 1699 (m, CO), 1601 (m), 1552 (m), 1452 (m), 1262 (m), 1081 (w), 810 (w), 627 (m).  $^1\text{H}$  NMR (400.1 MHz,  $\text{CDCl}_3$ ):  $\delta = 1.97$  (m, 2H, 3-H), 2.71 (m, 2H, 2-H), 3.00 (m, 2H, 4-H), 3.71 (s, 3H,  $\text{OCH}_3$ ), 4.66 (d, 1H,  $^3J = 5.9$  Hz, 5-H), 4.94 (d, 1H,  $^3J = 6.4$  Hz, 7-H), 5.29 (dd, 1H,  $^3J = 6.52$  Hz,  $^3J = 8.16$  Hz, 6-H).  $^{13}\text{C}$  NMR (100.6 MHz,  $\text{CDCl}_3$ , APT)  $\delta = 23.8$  (+, C-3), 39.9(+, C-4), 49.9 (+, C-2), 56.4 (-,  $\text{OCH}_3$ ), 85.1 (-, C-5), 93.7 (-, C-6), 97.6 (-, C-7), 139.7 (+, C-8a), 144.9 (+, C-4a), 160.2 (+, C-8), 187.2 (+, C-1), 231.9 (+, CO). - MS (70eV,  $145^{\circ}\text{C}$ ):  $m/z$  (%) = 312 (18) [ $\text{M}^+$ ], 256 (8) [ $\text{M} - 2\text{CO}$ ], 228 (60) [ $\text{M} - 3\text{CO}$ ], 195 (20), 161(100) [ $\text{M} - \text{Cr}(\text{CO})_3\text{CH}_3$ ], 144 (26), 115 (41), 91 (34), 73 (27), 52 (64) [Cr]. - HRMS ( $\text{C}_{14}\text{H}_{12}\text{CrO}_5$ ): calcd: 312.009065; found: 312.008983.

## 14 General Method for Addition of Lithium Alkyl Reagents to Complex **43** (GP II)

The alkyl lithium solution was added to the solution of 6-methoxybenzocyclobutenone complex **43** in THF slowly dropwise at  $-78^{\circ}\text{C}$ . The mixture was stirred for 1-5 h at  $-78^{\circ}\text{C}$ , then hydrolyzed with a saturated aqueous solution of  $\text{NH}_4\text{Cl}$  or 1M HCl. The reaction mixture was allowed to warm up to  $20^{\circ}\text{C}$  and extracted with TBME till the aqueous layer remained colorless. The collected organic layers were washed with 50 mL water two times and the organic solvent was dried over  $\text{MgSO}_4$ , filtered through a celite or silica gel filled P4-frit and washed with solvent until the silica gel remains colorless. The collected organic layers were evaporated at reduced pressure. The crude product was purified by column chromatography ( $200 \times 20$  mm,  $\text{SiO}_2$ , TBME/PE). The solvent was evaporated under reduced pressure.

### 14.1 Tricarbonyl $\{\eta^6$ -[1-(3-methoxyphenyl)-4-trimethylsilylbut-3-yne-2-one]]chromium (0) (**68**)

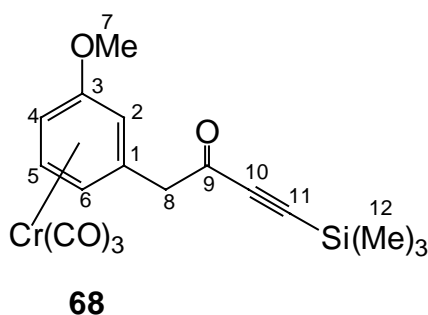

**GP II**; 0.7 ml (1.1 mmol) of 1.6 M butyllithium was in hexane added to 133 mg, (1.1 mmol) of trimethylsilylethyne in 20 mL of THF at  $-78^{\circ}\text{C}$ , warm up to  $-30^{\circ}\text{C}$ .<sup>125</sup> To the lithiated trimethylsilylethyne solution, added a solution of 250 mg (0.9 mmol) of complex **43** in 35 ml of THF at  $-78^{\circ}\text{C}$ , stirred 1h,

hydrolyzed with 10 mL 1M HCl at  $-78^{\circ}\text{C}$  and extracted with TBME, evaporation of the solvent at reduced pressure, the crude product purified by column chromatography (200  $\times$  20 mm, SiO<sub>2</sub>, TBME/PE, 4:1), 346mg (0.9 mmol, 86%) of **68** was obtained a red oil.

**68**: IR: (ATR):  $\tilde{\nu}$  = 2964 (w)  $\text{cm}^{-1}$ , 1962 (s, CO), 1878 (s, CO), 1678 (w), 1585 (w), 1464 (w), 1254 (w), 1151(w), 1105 (w), 847 (w), 762 (w), 677 (w), 633 (w). - <sup>1</sup>H-NMR (200 MHz, CDCl<sub>3</sub>):  $\delta$  = 0.25 (s, 9H, SiMe<sub>3</sub>), 3.71 (3H, OCH<sub>3</sub>), 4.10 (s, 2H, 8-H), 4.78 (d, 1H, <sup>3</sup>J = 6.3 Hz, 6-H), 5.03 (s, 1H, 2-H), 5.12 (d, 1H, <sup>3</sup>J = 6.5 Hz, 4-H), 5.58 (dd, 1H, <sup>3</sup>J = 6.5 Hz, <sup>3</sup>J = 6.3 Hz, 5-H). - <sup>13</sup>C NMR (100.6 MHz, CDCl<sub>3</sub>, APT):  $\delta$  = -1.3 (-, SiMe<sub>3</sub>), 50.5 (+, C-8), 55.3 (-, C-7), 77.7 (-, C-6), 79.8 (-, C-2), 86.7 (-, C-5), 94.6 (-, C-4), 100.6 (+, C-11), 102.2(+, C-10), 104.1 (+, C-1), 143 (+, C-3), 182.1 (+, C-9), 132.5 (+, CO). - MS (70eV, 80°C):  $m/z$  (%) = 382 (2)[M<sup>+</sup>], 298 (16) [M<sup>+</sup>-3CO], 274 (5), 244 (30), 226 (1), 204 (19), 186 (6), 160 (68), 117 (17), 91 (10), 73 (22), 52 (100) [Cr] -HRMS (C<sub>17</sub>H<sub>18</sub>CrO<sub>5</sub>Si): calcd. 282.033420; found. 382.032862. Calcd: C 54.24, H 3.98, found: C 54.62,H 4.19

#### 14.2 Tricarbonyl[ $\eta^6$ -{1-cyclopent-1-enyl-2-(3-methoxyphenyl)-ethanone}]chromium (0) (**69**)

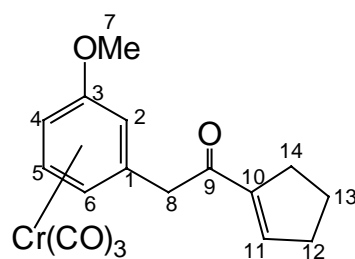

**69**

**GP II**, 155 mg (1.1 mmol) of 1-bromo-cyclopentene in 20 mL of THF and 9 mg (1.3 mmol) of lithium sand were heated at reflux for about 1h.<sup>110</sup> After

cooling to 25°C of it, a solution of 250 mg (0.9 mmol) of **43** in 35 mL of THF was added dropwise at -78°C. After stirring for 1h at -78°C, the mixture was hydrolyzed with 10mL of 1M HCl at -78°C, and extracted with TBME followed by evaporation, and purification by column chromatography (80 × 20 mm, SiO<sub>2</sub>, TBME/PE, 1:1), 275 mg (0.8 mmol, 89%) of **69** was obtained as an orange-yellow oil.

**69**: IR: (ATR):  $\tilde{\nu}$  = 3465 (w) cm<sup>-1</sup>, 2980 (w), 1951 (s, CO), 1854(s, CO), 1665 (m, C = O), 1579 (m), 1538 (m), 1461 (m), 1412 (w), 1364 (w), 1268 (m), 1152 (w), 1076 (m), 1033 (w), 993 (w), 829 (w), 780 (w), 676 (m). - <sup>1</sup>H NMR (400.1 MHz, CDCl<sub>3</sub>):  $\delta$  = 1.8 (m, 2H, 13-H), 2.23 (m, 2H, 14-H), 2.25 (m, 2H, 12-H), 3.70 (3H, OCH<sub>3</sub>), 3.78 (d, 2H, <sup>2</sup>J = 7.0 Hz, 8-H), 4.77 (d, 1H, <sup>3</sup>J = 6.5 Hz, 6-H), 5.08 (m, 2H, 4-H + 2-H), 5.50 (t, 1H, <sup>3</sup>J = 6.3 Hz, <sup>3</sup>J = 6.0 Hz, 5-H), 5.57 (m, 1H, 11-H). - <sup>13</sup>C NMR (100.6 MHz, CDCl<sub>3</sub>, APT):  $\delta$  = 22.7 (+, C-13), 30.6 (+, C-12 or 14), 34.2 (+, C-12 or 14), 44.6 (+, C-8), 55.5 (-, C-7), 75.5 (-, C-2), 80.6 (-, C-6), 87.4 (-, C-5), 94.9 (-, C-4), 106.9 (+, C-1), 126.4 (-, C-11), 143.4 (+, C-3), 145.1 (+, C-10), 193.9 (+, C-9), 233.2 (+, CO). - MS (70eV, 120°C): *m/z* (%) = 352 (6)[M<sup>+</sup>], 296 (9) [M - 2CO], 268 (69) [M - CO], 238 (12), 216 (28), 188 (10), 121 (7), 95 (100) [C<sub>5</sub>H<sub>7</sub>, CO], 73 (38), 52 (59) [Cr]. - HRMS (C<sub>17</sub>H<sub>16</sub>CrO<sub>5</sub>): Calcd: 352.040284; found: 352.040771.

**14.3 Tricarbonyl[ $\eta^6$ -{1-(3-methoxyphenyl)propan-2-one}]chromium (0)  
(70)**

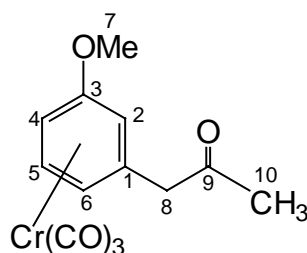

**70**

**GP II**, a solution of 1.7 mL (2.7 mmol) of 1.5 M methyllithium in diethyl ether was slowly added at  $-78^\circ\text{C}$  to a solution of 250 mg (0.9 mmol) of **43** in 35 mL THF. After stirring 1h, the mixture was hydrolyzed with 10 mL 1M HCl at  $-78^\circ\text{C}$ , extracted with 75 mL TBME, evaporation at reduced pressure, the crude product was purified by column chromatography (200  $\times$  20 mm,  $\text{SiO}_2$ , TBME/PE, 1:1), 211 mg (0.7mmol, 80%) of **70** was obtained as a pale yellow solid (m. p.  $105^\circ\text{C}$ ).

**70**: IR: (ATR):  $\tilde{\nu} = 2980$  (w)  $\text{cm}^{-1}$ , 1951 (s, CO), 1847 (s, CO), 1709 (s, C = O), 1522 (m), 1461 (w), 1413 (m), 1358 (w), 1276 (m), 1151 (m), 1038 (m), 993 (w), 839 (w), 666 (m). -  $^1\text{H}$  NMR (400.1 MHz,  $\text{CDCl}_3$ ):  $\delta = 2.28$  (s, 3H,  $\text{CH}_3$ ), 3.56 (s, 2H, 8-H), 3.71 (3H,  $\text{OCH}_3$ ), 4.73 (d, 1H,  $^3J = 5.9$  Hz, 6-H), 4.99 (s, 1H, 2-H), 5.10 (d, 1H,  $^3J = 6.02$  Hz, 4-H), 5.81 (t, 1H,  $^3J = 6.53$  Hz,  $^3J = 6.23$  Hz, 5-H). -  $^{13}\text{C}$  NMR (100.6 MHz,  $\text{CDCl}_3$ , APT):  $\delta = 29.6$  (-, C-10), 48.8 (+, C-8), 55.2 (-, C-7), 76.5 (-, C-2), 80.0 (-, C-6), 86.8 (-, C-4), 94.7 (-, C-5), 105.7 (+, C-3), 143.1 (+, C-1), 203.5 (+, C-9), 232.8 (+, CO). - MS (70eV,  $80^\circ\text{C}$ ):  $m/z$  (%) = 300 (16) [ $\text{M}^+$ ], 272 (4) [ $\text{M} - \text{CO}$ ], 244 (14) [ $\text{M} - 2\text{CO}$ ], 216 (100) [ $\text{M} - 3\text{CO}$ ], 190 (14), 173 (18), 121 (6), 80 (4), 52 (42) [Cr]. -

HRMS (C<sub>13</sub>H<sub>12</sub>CrO<sub>5</sub>): Calcd: 300.007721; found: 300.008983. Calcd: C 52.00, H 4.02; Found: C 52.42, H 4.13.

#### 14.4 Tricarbonyl[ $\eta^6$ -2-(3-methoxyphenyl)-1-phenylethanone]-chromium (0) (**71**)

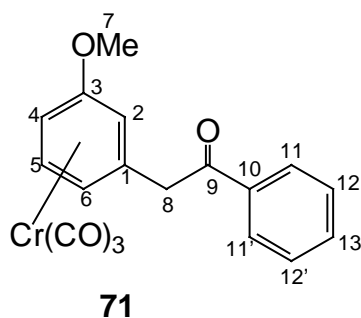

**GP II**, 0.44 ml (0.9 mmol) of 2 M phenyllithium in dibutyl ether was added dropwise to a solution of 250 mg (0.88 mmol) of **43** in 35 mL of THF at  $-78^{\circ}\text{C}$ . After stirring for 1h, the mixture was hydrolyzed with 10 mL of 1M HCl at  $-78^{\circ}\text{C}$  and extracted 3 times with 30 mL of TBME, evaporation at reduced pressure, a crude product was purified by column chromatography (80  $\times$  20 mm, SiO<sub>2</sub>, TBME/PE, 1:1), 383 mg (0.7 mmol, 80%) of **71** was obtained as a pale yellow oil.

**71**: IR: (ATR):  $\tilde{\nu}$  = 3097 (w) cm<sup>-1</sup>, 2924 (w), 1950 (s, CO), 1849 (s, CO), 1730 (m, C=O), 1685 (s), 1595 (w), 1581 (w), 1537 (m), 1459 (m), 1413 (w), 1330 (m), 1268 (s), 1214 (m), 1150 (m), 1103 (w), 1027 (m), 1001 (m), 987 (m), 917 (w), 895 (w), 809 (w), 781 (m), 755 (m), 669 (s). - <sup>1</sup>H NMR (400.1 MHz, acetone-*d*<sub>6</sub>):  $\delta$  = 3.78 (3H, OCH<sub>3</sub>), 4.32 (s, 2H, 8-H), 5.20(d, 1H, <sup>3</sup>*J* = 6.4 Hz, 6-H), 5.46 (d, 1H, <sup>3</sup>*J* = 6.8 Hz, 4-H), 5.55 (s, 1H, 2-H), 5.91 (dd, 1H, <sup>3</sup>*J* = 6.53 Hz, <sup>3</sup>*J* = 6.77Hz, 5-H), 7.57(t, 2H, <sup>3</sup>*J* = 7.4 Hz, <sup>3</sup>*J* = 7.18 Hz, 12(12')-H), 7.66 (dd, 1H, <sup>3</sup>*J* = 7.41 Hz, <sup>3</sup>*J* = 7.27 Hz, 13-H), 8.10 (d, 1H, <sup>2</sup>*J* = 7.16 Hz, 11(11')-H). - <sup>13</sup>C NMR (100.6 MHz, acetone-*d*<sub>6</sub>, APT):  $\delta$  = 43.9 (+, C-8), 55.2(-, C-7), 77.7 (-, C-2), 81.9 (-, C-6), 88.7 (-, C-5), 94.9 (-, C-4), 108.9

(+, C-1), 127.9 (–, C-12 + 12'), 128.6(–, C-11 + 11'), 133.2 (–, C-13), 136.3 (+, C-10), 144.1 (+, C-3), 195.5 (+, C-9), 233.9 (+, CO). -MS (70eV, 100°C):  $m/z$  (%) = 362 (3) [ $M^+$ ], 306 (3) [ $M - 2CO$ ], 278 (37) [ $M - 3CO$ ], 261 (8), 244 (33), 226 (26), 204 (34), 187 (6), 160 (54), 129 (2), 105 (100) [ $C_6H_5CO$ ], 90 (2), 77 (32), 52 (69) [Cr]. - CHN analysis  $C_{18}H_{14}CrO_5$  (362.3016): Cal. C 59.67, H 3.89, Found C 59.87, H 3.55.

#### 14.5 Tricarbonyl[ $\eta^6$ -(1-furanyl)-2-(3-methoxy-phenyl)ethanone] chromium (0) (**72**)

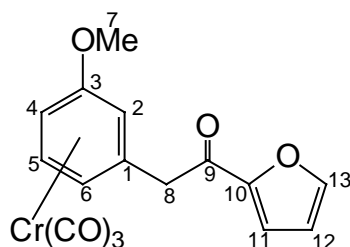

**72**

**GP II**, 43 mg (0.63 mmol) of furane in 10 mL of THF and 0.4 mL (0.7 mmol) of 1.5 M butyllithium in hexane and warm up to 20°C, to the solution,<sup>129</sup> added dropwise a solution of 150 mg (0.53 mmol) of **43** in 35 ml THF at –78°C. After stirring 1h, hydrolyzed with 10 mL of 1M HCl at –78°C and extracted 3 times with 20 mL of TBME, evaporation, the crude product purified by column chromatography (80 × 20 mm, SiO<sub>2</sub>, TBME/PE, 2:1), 172 mg (0.5 mmol, 92%) of **72** was obtained as a pale yellow oil.

**72**. IR: (ATR):  $\tilde{\nu}$  = 3401 (w)  $cm^{-1}$ , 2941 (w), 1950 (s, CO), 1849 (s, CO), 1672 (m, C = O), 1565 (w), 1537 (m), 1521 (m), 1462 (m), 1422 (w), 1392 (m), 1269 (s), 1153 (m), 1062 (w), 1024 (m), 990 (m), 913 (w), 882 (w), 819 (w), 766 (m), 674 (m), 624 (s). - <sup>1</sup>H NMR (400.1 MHz, acetone-*d*<sub>6</sub>):  $\delta$  = 3.77

(3H, OCH<sub>3</sub>), 4.10 (s, 2H, 8-H), 5.20(d, 1H, <sup>3</sup>J = 6.3 Hz, 6-H), 5.42 (d, 1H, <sup>3</sup>J = 6.9 Hz, 4-H), 5.55 (s, 1H, 2-H), 5.90 (dd, 1H, <sup>3</sup>J = 6.53 Hz, <sup>3</sup>J = 6.7 Hz, 5-H), 6.7(dd, 1H, <sup>3</sup>J = 1.6 Hz, <sup>3</sup>J = 1.6 Hz, 12-H), 7.5 (d, 1H, <sup>3</sup>J = 3.3 Hz 11-H), 7.9 (s, 1H, 13-H). - <sup>13</sup>C NMR (100.6 MHz, acetone-*d*<sub>6</sub>, APT): δ = 43.3 (+, C-8), 55.0(-, C-7), 77.5 (-, C-2), 81.4 (-, C-6), 88.3 (-, C-5), 95.9 (-, C-4), 107.9 (+, C-1), 112.2 (-, C-11 + 12), 1<sup>^</sup>17.7(-, C-13), 143.9 (+, C-3), 151.6 (+, C-10), 183.8 (+, C-9), 233.6 (+, CO). -MS (70eV, 100°C): *m/z* (%) = 352 (34) [M<sup>+</sup>], 296 (20) [M - 2CO], 268 (100) [M - 3CO], 235 (11), 216 (33), 199 (49), 173 (4), 147 (14), 121 (9), 95 (55), 73 (94), 52 (37) [Cr]. - HRMS (C<sub>16</sub>H<sub>12</sub>CrO<sub>5</sub>): calcd: 352.003898; found: 352.001759; calcd C 54.59 H 3.43, found C 54.54 H 4.00

#### 14.6 Tricarbonyl[η<sup>6</sup>-{1,1-difuranyl)-2-(3-methoxyphenyl)-ethanone]chromium (0) (74)

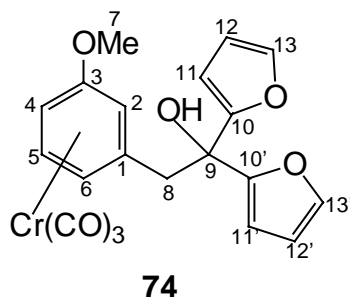

**GP II**, 258 mg of (1.76 mmol) furan in 10 mL of THF and 1.21 mL (1.936 mmol) of 1.6 M butyllithium in hexane was added at -78°C and warmed up to 20 °C over 45 min. and stirred it for 30 min at 20°C. After cooling it to -78 °C, a solution of 250 mg (0.88 mmol) of complex **43** in 35 mL THF was added slowly dropwise. After stirring 1h at -78 °C, hydrolyzed with 10 mL 1M HCl at -78°C and extraction 3 times with 30 mL of TBME, evaporation at reduced pressure, a crude product purified by column chromatography (200 × 20 mm,



SiO<sub>2</sub>, TBME/PE, 2:1), 328mg (0.8 mmol, 89%) of **74** was obtained as an orange-yellow oil.

**74**: IR: (ATR):  $\tilde{\nu}$  = 3566 (br, w) cm<sup>-1</sup>, 2974 (w), 1952 (s, CO), 1853 (s, CO), 1672 (w), 1538 (w), 1521 (w), 1461 (m), 1411 (w), 1365 (w), 1265 (m), 1151 (m), 1066 (m), 1012 (m), 909 (w), 883 (w), 736 (m), 664 (m). - <sup>1</sup>H NMR (400.1 MHz, benzene-*d*<sub>6</sub>):  $\delta$  = 2.09 (s, 1H, OH), 2.93 (3H, OCH<sub>3</sub>), 3.20 (s, 2H, 8-H), 4.18 (d, 1H, <sup>3</sup>*J* = 6.3 Hz, 6-H), 4.26 (d, 1H, <sup>3</sup>*J* = 5.9 Hz, 4-H), 4.63 (s, 1H, 2-H), 4.70 (dd, <sup>3</sup>*J* = 6.8 Hz, <sup>3</sup>*J* = 6.4 Hz, 5-H), 6.01 (m, 4H, 12(12')-H + 13(13')-H), 6.96 (m, 2H, 11(11')-H). - <sup>13</sup>C NMR (100.6 MHz, acetone-*d*<sub>6</sub>, APT):  $\delta$  = 44.9 (+, C-8), 55.0 (-, C-7), 77.6 (-, C-2), 79.5 (-, C-6), 87.6 (-, C-5), 95.2 (-, C-4), 107.8 (-, C-1), 109.4 (+, C-9), 110.7 (-, C-12(12')), 111.8(-, C-11(11')), 122.9 (-, C-13(13')), 143.1 (+, C-3), 147.8 (+, C-10 (10')), 234.0 (+, CO). - MS (70eV, 110°C): *m/z* (%) = 420 (7) [M<sup>+</sup>], 392 (1) [M - CO], 336 (20) [M - 3CO], 308 (16), 268 (28), 244 (12), 216 (20), 188 (5), 163 (21), 145 (3), 121 (13), 95 (39), 52 (32) [Cr]. -HRMS (C<sub>20</sub>H<sub>16</sub>CrO<sub>7</sub>): calcd. 420.030113; found. 420.030090.

#### 14.7 Elimination of water from complex **74**

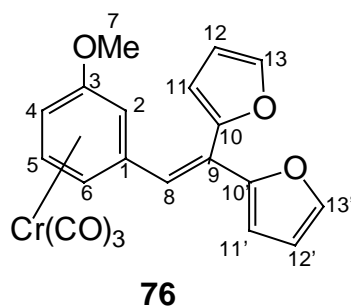

The 100 mg (0.23 mmol) of **74** in 10 mL diethyl ether was treated with 10 mL 2 M HCl solution. The color changed immediately from orange-yellow to orange-red. After stirring for 1 h, extracted 3 times with 30 mL of TBME, evaporation at reduced pressure, a crude product was purified by column

chromatography (200 × 20 mm, SiO<sub>2</sub>, TBME/PE, 2:1), 90 mg (0.23 mmol, 98%), an orange-red solid was obtained (m. p.96 °C).

**76:** IR: (ATR):  $\tilde{\nu}$  = 2970 (w) cm<sup>-1</sup>, 1948 (s, CO), 1853 (s, CO), 1678 (w), 1615 (w), 1556 (w), 1531 (w), 1481 (w), 1455 (w), 1400 (w), 1344 (w), 1276 (m), 1219 (w), 1155 (m), 1015 (m), 962 (w), 884 (w), 812 (w), 739 (m), 683 (w). - <sup>1</sup>H NMR (400.1 MHz, benzene-*d*<sub>6</sub>):  $\delta$  = 2.92 (s, 3H, OCH<sub>3</sub>), 4.21 (d, 1H, <sup>3</sup>*J* = 6.4 Hz, 6-H), 4.30 (d, 1H, <sup>3</sup>*J* = 6.8 Hz, 4-H), 4.65 (s, 1H, 2-H), 4.67 (dd, <sup>3</sup>*J* = 6.5 Hz, <sup>3</sup>*J* = 6.7 Hz, 5-H), 6.01 (m, 2H, 12(12')-H), 6.12 (d, 1H, <sup>3</sup>*J* = 2.9 Hz, 11-H), 6.20 (d, 1H, <sup>3</sup>*J* = 3.3 Hz, 11'-H), 6.80 (s, 1H, 8-H), 6.90 (d, 1H, 13-H), 7.02 (d, 1H, 13'-H). - <sup>13</sup>C NMR (100.6 MHz, acetone-*d*<sub>6</sub>, APT):  $\delta$  = 55.0 (-, OCH<sub>3</sub>), 77.7 (-, C-2), 79.4 (-, C-6), 87.6 (-, C-5), 94.5 (-, C-4), 108.0 (+, C-1), 111.8-113.1 (-, C-11(11') + C-12(12')), 124.5 (-, C-9), 124.7 (+, C-8), 143.1 (+, C-13 or 13'), 143.5 (+, C-3), 144.4 (-, C-13' or 13), 149.6 (+, C-10 or 10'), 153.6 (+, C-10 or 10'), 234.7 (+, CO). -MS (70eV, 90°C): *m/z* (%) = 402 (34) [M<sup>+</sup>], 346 (4) [M - 2CO], 318 (100) [M - 3CO], 292 (11), 264 (14), 233 (4), 216 (10), 195 (4), 163 (8), 139 (2), 121 (5), 95 (17), 73 (9), 52 (19) [Cr]. -HRMS (C<sub>20</sub>H<sub>14</sub>CrO<sub>6</sub>): calcd. 402.019548; found. 402.019379. Calcd. 59.70 H 4.01, found C 56.39 H 4.36.

#### 14.8 Tricarbonyl[ $\eta^6$ -2-(3-methoxyphenyl)-1-diphenylethanone]-chromium (0) (75)

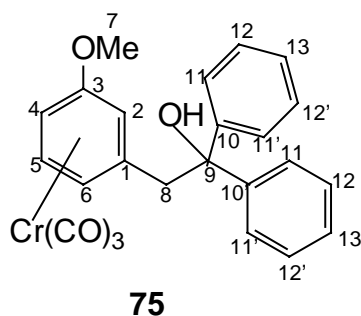

**GP II**, 0.9 mL (1.78 mmol) of 2.5 M phenyllithium in dibutyl ether was slowly added to a solution of 250 mg (0.9 mmol) of **43** in 35 mL of THF at  $-78^{\circ}\text{C}$ . After stirring 1h, hydrolysis with 10 mL 1M HCl at  $-78^{\circ}\text{C}$  and extraction 3 times with 30 mL TBME, evaporation, the crude product, and purification by column chromatography (200 × 20 mm, SiO<sub>2</sub>, TBME/PE, 2:1), 309 mg (0.7mmol, 80%) of **75** was obtained as a yellow oil.

**75**: IR: (ATR):  $\tilde{\nu} = 3480$  (br, w)  $\text{cm}^{-1}$ , 2940 (w), 1949 (s, CO), 1849 (s, CO), 1847 (s, CO), 1681 (m), 1595 (w), 1582 (w), 1538 (m), 1448 (m), 1410 (w), 1326 (w), 1265 (s), 1204 (m), 1153 (m), 1030 (m), 992 (w), 918 (w), 827 (w), 779 (w), 752 (w), 669 (s). - <sup>1</sup>H NMR (400.1 MHz, acetone, d<sub>6</sub>):  $\delta = 3.47$  (s, 2H, 8-H), 3.56 (3H, OCH<sub>3</sub>), 3.75 (s, OH), 4.83 (d, 1H, <sup>3</sup>J = 6.2 Hz, 6-H), 5.02 (s, 1H, 2-H), 5.24 (d, 1H, <sup>3</sup>J = 5.5 Hz, 4-H), 5.66 (dd, <sup>3</sup>J = 6.6 Hz, <sup>3</sup>J = 6.5 Hz, 5-H), 7.24 (dd, 2H, <sup>3</sup>J = 7.0 Hz, <sup>3</sup>J = 6.6 Hz, 13(13')-H), 7.24 (m, 4H, 12(12')-H), 7.50(m, 4H, 11(11')-H). - <sup>13</sup>C NMR (100.6 MHz, acetone, d<sub>6</sub>, APT):  $\delta = 47.1$  (+, C-8), 54.7 (−, OCH<sub>3</sub>), 77.6 (−, C-2), 82.5 (−, C-6), 89.6 (−, C-5), 95.2 (−, C-4), 110.9 (+, C-3), 127.5 (−, *o*-C or *m*-C), 127.8 (−, *o*-C or *m*-C), 128.4 (−, *p*-C), 143.3 (+, C-3), 143.9 (+, C-9), 146.5 (+, C-10), 234.0 (+, CO). - MS (70eV, 140°C): *m/z* (%) = 440 (7) [M<sup>+</sup>], 356 (45) [M − 3CO], 279 (100) [M − 3CO-C<sub>6</sub>H<sub>5</sub>], 227 (20), 183 (36), 160 (6), 139 (2), 106 (11), 77 (36), 52 (28) [Cr].

**15 Tricarbonyl[ $\eta^6$ -*N*-(2,2-Dimethylpent-4-enyl)-2-(3-methoxyphenyl)acetamide]chromium (0) (**84**)**

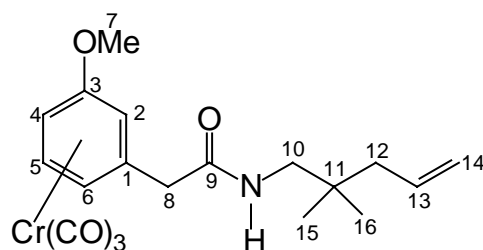

**84**

119 mg (1.1 mmol) of *N*-(2,2-Dimethylpent-4-enyl) was slowly added dropwise to a solution of 200 mg (0.7 mmol) of **43** in 50 mL of diethyl ether. The reaction mixture was stirred for 3 days in the dark. The color of the reaction solution changed from orange to yellow. The solvent was evaporated at reduced pressure. The crude yellow oil was purified by column chromatography (200 × 20 mm, SiO<sub>2</sub>, TBME/PE, 2:1), 237 mg (0.6 mmol, 85%) of **84** was obtained as yellow oil.

**84**: IR: (ATR):  $\tilde{\nu}$  = 3684 (w, br, OH) cm<sup>-1</sup>, 3446 (w, N-H), 2964 (w), 1968 (s, CO), 1892 (s, CO), 1674 (m), 1603 (w), 1521 (m, C-N), 1461 (w), 1274 (m), 1152 (w), 1036 (w), 921 (w), 822 (w), 534 (w). - <sup>1</sup>H NMR (200.1 MHz, CDCl<sub>3</sub>):  $\delta$  = 0.88 (s, 6H, 2 × CH<sub>3</sub>), 1.98 (d, 2H, <sup>2</sup>J = -7.40 Hz, 10-H), 3.13 (d, 2H, <sup>2</sup>J = -6.14 Hz, 8-H), 3.34 (s, 2H, 12-H), 3.70 (3H, OCH<sub>3</sub>), 4.87 (d, 1H, <sup>3</sup>J = 6.3 Hz, 6-H), 5.16 (m, 4H, 14-H, 2-H, 4-H), 5.62 (t, 1H, <sup>3</sup>J = 6.52 Hz, 5-H), 5.81 (m, 1H, 13-H), 5.97 (s, br, 1H, NH). - <sup>13</sup>C NMR (100.1 MHz, CDCl<sub>3</sub>, APT):  $\delta$  = 21.5 (-, C-15 + C-16), 35.3 (+, C-12), 45.1 (d, +, C-8), 49.9 (+, C-10), 56.2 (-, C-7), 61.0 (+, C-9), 77.5 (-, C-2), 80.6 (-, C-6), 87.4 (-, C-4), 95.7 (-, C-5), 108.5 (+, C-1), 118.3 (+, C-13), 135.2 (-, C-14), 144.2 (+, C-7), 169.4 (+, C-9), 233.9 (+, CO). - MS (70eV, 145°C): *m/z* (%) = 397 (1) [M<sup>+</sup>], 369 (2) [M - CO], 341 (6) [M - 2CO], 313 (100) [M - 3CO], 288 (7), 261 (18), 244 (20), 204 (27), 173 (21), 148 (52), 121 (40), 90 (38), 77 (17), 52 (93) [Cr]. - HRMS (C<sub>19</sub>H<sub>23</sub>CrN<sub>1</sub>O<sub>5</sub>): calcd: 397.098145; found: 397.098133.

## 16 General Procedure for the Anionic Ring Opening and [4+2] Cycloaddition with **58** (GP III)

The 1-*endo*-hydroxy-6-methoxycyclobutene complex **58** is dissolved in 50 mL THF. 1.1 equiv. of butyllithium in hexane is added, and the mixture is

cooled at  $-78^{\circ}\text{C}$ . The color changes from yellow to orange-yellow indicating deprotonation of alcohol. After stirring the reaction mixture at  $-78^{\circ}\text{C}$  for 45 min, 2- 10 equiv. of the dienophile is added. The reaction is warmed up to  $20^{\circ}\text{C}$  over 4 - 20 h. The reaction is hydrolyzed with a saturated aqueous solution of ammonium chloride or 1 M hydrochloric acid at  $-78^{\circ}\text{C}$ , warmed up to  $20^{\circ}\text{C}$  and diluted by addition of argonated water and TBME. The aqueous layer is extracted with TBME until it remains colorless. The collected organic layers are dried over  $\text{MgSO}_4$ , filtered through a celite or silica gel filled P4-frit and washed with solvent till the silica gel of frit remains colorless. The organic solvent is evaporated at reduced pressure. The crude product is purified by column chromatography ( $200 \times 20$  mm,  $\text{SiO}_2$ ) eluted first with pure petroleum ether, then with mixture of TBME/PE.

### 16.1 Anionic Ring Opening and [4+2] Cycloaddition complex **58** with Methyl acrylate

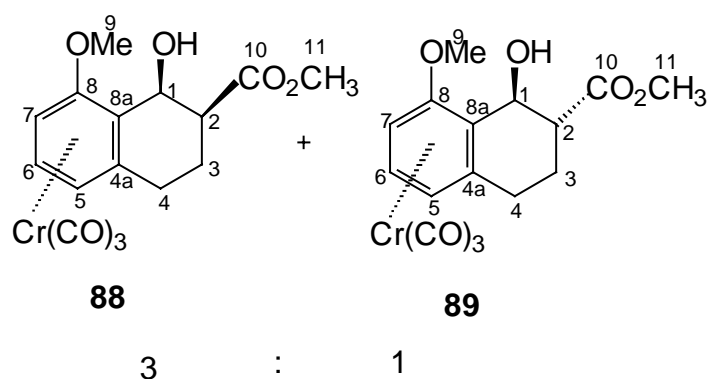

**GP III**; 0.8 mL (1.4 mmol) of 1.6 M butyllithium in hexane, 350 mg (1.2 mmol) of **58** in 50 mL of THF at  $-78^{\circ}\text{C}$ , stirred for 45 min, added 408 mg (4.8 mmol) of methyl acrylate, warm up to  $20^{\circ}\text{C}$  over 20 hours. Hydrolysis with 10 mL of saturated aqueous  $\text{NH}_4\text{Cl}$  solution at  $-78^{\circ}\text{C}$ , extracted 3 times with 30 mL TBME, purified by column chromatography ( $200 \times 20$  mm,  $\text{SiO}_2$ ,

TBME/PE, 2:1), 364 mg (1.0 mmol, 80%) of Tricarbonyl[ $\eta^6$ -1,2,3,4-tetrahydro-1-*exo*-hydroxy-2-*exo*-methylcarbonyl]-8-methoxynaphthalene]-chromium (0) **88** and Tricarbonyl[ $\eta^6$ -1,2,3,4-tetrahydro-1-*exo*-hydroxy-2-*endo*-methylcarbonyl]-8-methoxynaphthalene]chromium (0) **89** were obtained as a yellow oil.  $^1\text{H}$  NMR and  $^{13}\text{C}$  NMR indicated **88/89** = 3:1.

**88/89**: IR: (ATR):  $\tilde{\nu}$  = 3530 (br, OH)  $\text{cm}^{-1}$ , 2953 (m), 1958 (s, CO), 1927 (s, CO), 1875 (s, CO), 1731 (s, C=O), 1675 (w), 1438 (m), 1377 (w), 1257 (m), 1204 (m), 1167 (m), 1024 (w), 828 (w), 673 (w). -  $^1\text{H}$  NMR (200.1 MHz,  $\text{CDCl}_3$ ): **88**:  $\delta$  = 2.03 (m, 1H, 3 $\beta$ -H), 2.21 (m, 1H, 4 $\alpha$ -H), 2.30 (dd, 1H, 4 $\alpha$ -H), 2.44 (dd, 1H, 4 $\beta$ -H), 2.57 (1H, 2-H), 3.68 (3H,  $\text{OCH}_3$ ), 3.72 (3H,  $\text{OCH}_3$ ), 3.81 (s, 1H, OH), 4.71 (d, 1H,  $^3J$  = 5.8 Hz, 5-H), 4.48 (d, 1H,  $^3J$  = 6.6 Hz, 7-H), 5.05 (m, 1H,  $^3J_{\text{trans}1-2}$  = 18.9 Hz, 1-H), 5.55 (dd, 1H,  $^3J$  = 6.27 Hz,  $^3J$  = 6.03 Hz, 6-H). -  $^{13}\text{C}$  NMR (100.6 MHz,  $\text{CDCl}_3$ , APT): **89**:  $\delta$  = 25.6 (+, C-3), 30.9 (+, C-4), 51.1 (-, C-11), 53.7 (-, C-1), 55.5 (-, C-9), 76.6 (-, C-2), 79.1 (-, C-5), 86.0 (-, C-7), 93.7 (-, C-6), 107.2 (+, C-8a), 142.5 (+, C-4a), 172.6 (+,  $\text{CO}_2\text{CH}_3$ ), 233.2 (+, CO). - MS (70eV, 120°C):  $m/z$  (%) = 372 (9) [ $\text{M}^+$ ], 316 (19) [ $\text{M} - 2\text{CO}$ ], 288 (64) [ $\text{M} - 3\text{CO}$ ], 257 (14), 232 (31), 202 (50), 174 (13), 154 (50), 115 (6), 91 (13), 73 (100) [ $\text{CH}_3\text{CO}_2\text{CH}_2$ ], 52 (47) [ $\text{Cr}$ ]. -HRMS ( $\text{C}_{16}\text{H}_{16}\text{CrO}_7$ ): calcd: 372.030121 found: 372.030133.

## 16.2 Anionic Ring Opening and [4+2] Cycloaddition Complex **58** with Dimethyl Fumarate

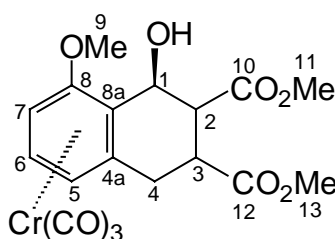

**94**

**GP III**; 0.5 mL (0.77 mmol) of 1.6 M butyllithium in hexane was added to 200 mg (0.70 mmol) of **58** in 50 mL of THF at  $-78^{\circ}\text{C}$ , stirred for 1h, addition of 402 mg (2.8 mmol) of dimethyl fumarate in 10 mL THF, warm up to  $20^{\circ}\text{C}$  in 20 hours. Hydrolysis with saturated aqueous  $\text{NH}_4\text{Cl}$  at  $-78^{\circ}\text{C}$ , extracted 3 times with 30 mL of TBME. The crude product was purified by column chromatography ( $200 \times 20$  mm, PE, then TBME/PE, 2:1), 185 mg (0.43 mmol, 56%) Tricarbonyl[ $\eta^6$ -1,2,3,4-tetrahydro-1-hydroxy-2,3-(dime-thoxycarbonyl)-8-methoxynaph-thalene]chromium (0) (**94**) was obtained as yellow oil.

**94**: IR ( $\text{CHCl}_3$ ):  $\tilde{\nu} = 3041 \text{ cm}^{-1}$  (w), 2955 (w), 1972 (s, C=O), 1898 (s, C=O), 1736 (m), 1535 (w), 1439 (m), 1230 (m), 1091 (m), 1027 (m). -  $^1\text{H}$  NMR (400.1 MHz,  $\text{CDCl}_3$ ):  $\delta = 2.59 - 3.39$  (m, 5H, OH + 2-H + 3-H + 4-H), 3.69 - 3.81 (m, 9H,  $3 \times \text{OCH}_3$ ), 4.74-5.54 (m, 4H, 1-H + 5-H + 6-H + 7-H). -  $^{13}\text{C}$  NMR (100.6 MHz,  $\text{CDCl}_3$ , APT):  $\delta = 33.2$  (+, C-4), 37.0 (-, C-3), 48.3 (-, C-2), 52.5 (-,  $\text{OCH}_3$ ), 55.9 (-,  $\text{OCH}_3$ ), 56.2 (-, C-9), 64.0 (-, C-1), 88.4 (-, C-5), 86.9 (-, C-6), 94.0 (-, C-7), 104.1 (+, C-4a), 125.3 (+, C-8a), 157.8 (+, C-8), 171.7 (+, CO-ester), 172.7 (+, CO-ester), 232.5 (+, CO). - MS (70 eV,  $130^{\circ}\text{C}$ ):  $m/z$  (%) = 430 (3) [ $\text{M}^+$ ], 374 (7) [ $\text{M} - 2\text{CO}$ ], 346 (18) [ $\text{M} - 3\text{CO}$ ], 314 (18), 286 (9), 266 (15), 232 (29), 202 (36), 175 (68), 147 (24), 115 (23), 91 (23), 73 (100)[ $\text{CH}_2\text{CO}_2\text{CH}_3$ ], 52 (67) [Cr]. - HRMS ( $\text{C}_{18}\text{H}_{18}\text{CrO}_9$ ): calcd. 430.035592, found: 430.035522.

### 16.3 Anionic Ring Opening and [4+2] Cycloaddition complex **58** with Phenyl Vinyl Sulfone

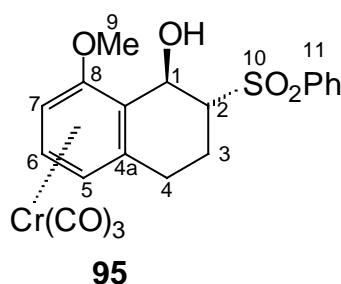

**GP III**; 0.8 mL (1.2 mmol) of 1.6 M butyllithium in hexane, 300 mg (1.1 mmol) of **58** in THF at  $-78^{\circ}\text{C}$ , stirred for 45 h, 739 mg (4.4 mmol) of phenyl vinyl sulfone, warm up to  $20^{\circ}\text{C}$  over 20 hours. Hydrolysis with 10 mL of saturated aqueous  $\text{NH}_4\text{Cl}$  at  $-78^{\circ}\text{C}$ , extracted with TBME, evaporation, purified by column chromatography ( $200 \times 20$  mm, first eluted PE, TBME/PE, 2:1), 400 mg (0.88 mmol, 84%) of Tricarbonyl[ $\eta^6$ -1,2,3,4-tetrahydro-1-exo-hydroxy-2-endo-phenylsulfonyl-8-methoxynaphthalene]-chromium (0) (**95**) was obtained as a yellow oil.

**95**: IR: (ATR):  $\tilde{\nu} = 2936$  (w)  $\text{cm}^{-1}$ , 1950 (s, CO), 1847 (s, CO), 1722 (s, C=O), 1585 (w), 1536 (m), 1447 (m), 1408 (w), 1264 (m), 1144 (s,  $\text{SO}_2$ ), 1084 (m), 1024 (w), 799 (w), 734 (w), 686 (s), 662 (s).  $^1\text{H}$  NMR (200.1 MHz,  $\text{CDCl}_3$ ):  $\delta = 2.12$  (ddd, 1H,  $3\beta\text{-H}$ ), 2.40 (ddd, 1H,  $4\beta\text{-H}$ ), 3.17 (ddd, 1H,  $4\alpha\text{-H}$ ) 3.61 (dd, 1H,  $3\alpha\text{-H}$ ), 3.70 (ddd, 1H, 2-H), 3.74 (3H,  $\text{OCH}_3$ ), 4.59 (d, 1H, OH,  $^3J = 6.2$  Hz), 4.83 (d, 1H,  $^3J = 5.8$  Hz, 5-H), 5.14 (d, 1H,  $^3J = 5.6$  Hz, 7-H), 5.24 (d, 1H,  $^3J_{1,2} = 8.8$  Hz, 1-H), 5.55 (t, 1H,  $^3J = 6.7$  Hz,  $^3J = 6.2$  Hz, 6-H), 7.58 (dd, 2H,  $^3J = 7.9$  Hz,  $^3J = 8.6$  Hz, *m*-H), 7.62 (d, 1H, *p*-H), 7.91 (d, 2H, *o*-H).  $^{13}\text{C}$  NMR (100.6 MHz,  $\text{CDCl}_3$ , APT):  $\delta = 24.5$  (+, C-3), 26.9 (–, C-4), 53.1(–, C-1), 53.2 (–, C-2), 55.9 (–, C-9), 78.6 (–, C-5), 85.6 (–, C-7), 93.8 (–, C-6), 105.9 (+, C-4a), 127 (–, *m*-C), 129.5 (–, *o*-C), 134.1 (–, *p*-C), 138.6 (+, ipso-C), 142.6 (+, C-8a), 232.2 (+, CO). MS (70eV,  $190^{\circ}\text{C}$ ):  $m/z$  (%) = 454 (2) [ $\text{M}^+$ ], 398 (5) [ $\text{M} - 2\text{CO}$ ], 370 (32) [ $\text{M} - \text{CO}$ ], 342 (6), 318 (23), 290 (31), 250 (3), 220 (12), 200 (9), 176 (31), 148 (100) [ $\text{M} - \text{Cr}(\text{CO})_3\text{C}_2\text{H}_5\text{SO}_2\text{C}_6\text{H}_5$ ], 121(20), 92(4), 77(30), 52(31) (Cr). -HRMS ( $\text{C}_{20}\text{H}_{18}\text{CrO}_7\text{S}$ ): calcd: 454.014847; found: 454.014463. Calcd.: C 52.86, H 3.99; found: C 52.63, H 4.36.



## 16.4 Anionic Ring Opening and [4+2] Cycloaddition of Complex **58** with Dimethylbutynedioate

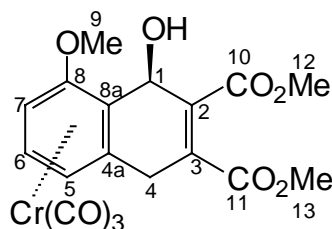

**100**

**GP III**; 0.6 mL (0.96 mmol) of 1.6 M butyllithium in hexane and 250 mg (0.9 mmol) of **58** in 15 mL of THF at  $-78^{\circ}\text{C}$ , stirred for 45 min, addition of 511 mg (3.6 mmol) dimethylbutynedioate, warming up to  $20^{\circ}\text{C}$  over 20 hours. Hydrolysis with 10 mL of saturated aqueous  $\text{NH}_4\text{Cl}$  at  $-78^{\circ}\text{C}$ , extracting 3 times with 25 mL of TBME, evaporation, crude product was purified by column chromatography (200  $\times$  20 mm, PE, then TBME/PE, 2:1), 231 mg (0.54 mmol, 62%) of tricarbonyl[ $\eta^6$ -1,4-dihydro-1-*endo*-hydroxy-2,3-di(methoxycarbonyl)-8-methoxynaphthalene]chromium (0) (**100**) was obtained as the yellow oil.

**100**: IR ( $\text{CHCl}_3$ ):  $\tilde{\nu} = 2953$  (m)  $\text{cm}^{-1}$ , 1969 (s, C=O), 1892 (s, C=O), 1736 (s), 1630 (m), 1437 (m), 1147 (s), 1097 (m). -  $^1\text{H}$  NMR (400.1 MHz, acetone- $d_6$ ):  $\delta = 3.67$ (s, 3H,  $\text{OCH}_3$ ), 3.77 (s, 3H,  $\text{OCH}_3$ ), 3.78 - 3.82 (m, 2H, 4-H), 3.83 (s, 3H,  $\text{OCH}_3$ ), 5.11 - 5.80 (m, 3H, 1-H + 5-H + 6-H), 6.77 (d, 1H, 7-H).-  $^{13}\text{C}$  NMR (100.6 MHz, acetone- $d_6$ , APT):  $\delta = 38.6$  (+, C-4), 50.4 (-,  $\text{CH}_3$ ), 51.5 (-,  $\text{CH}_3$ ), 56.5 (-, C-9), 72.9 (-, C-1), 92.0 (-, C-5 or C-6 or C-7), 93.1 (-, C-5 or C-6 or C-7), 94.8 (-, C-5 or C-6 or C-7), 96.7 (+, C-4a), 114.7 (+, C-8a), 130.0 (-, C-3), 132.0 (-, C-2), 140.1 (+, C-8), 162.4 (+, Ester), 164.3 (+, Ester), 232.7 (+, CO).- MS (70 eV,  $80^{\circ}\text{C}$ ):  $m/z$  (%) = 428 (2) [ $\text{M}^+$ ], 400 (2), 372 (2), 286 (11), 202 (25), 133 (100), 52 (34). - HRMS ( $\text{C}_{18}\text{H}_{16}\text{CrO}_9$ ) 428.316: Calcd.

428.0199942; found: 4.28.019867. Calcd. C 50.81, H 4.26; founded. 51.48, H 4.33.

### 16.5 Tricarbonyl[ $\eta^6$ -1-(3-methoxyphenyl)hept-6-en-2-one]chromium (0)

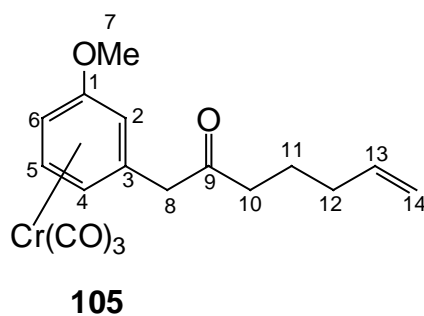

0.6 ml (0.96 mmol) of 1.6 M butyllithium in hexane and 250 mg (0.9 mmol) of **58** in 50 mL THF at  $-78\text{ }^{\circ}\text{C}$ ; warm up to  $20\text{ }^{\circ}\text{C}$  overnight. Hydrolysis with saturated aqueous  $\text{NH}_4\text{Cl}$  at  $-78\text{ }^{\circ}\text{C}$ , extracted with TBME, purification by column chromatography ( $200 \times 20\text{ mm}$ , PE, then TBME/PE, 2:1), 185 mg (0.524 mmol, 60%) of **105** was obtained as the yellow oil.

**105** IR: ( $\text{CDCl}_3$ ):  $\tilde{\nu} = 3092\text{ (w)}\text{ cm}^{-1}$ , 2940(w), 1956 (s, CO), 1866 (s, CO), 1732 (m, C=O), 1639 (w), 1539 (m), 1460 (m), 1415(w), 1335 (w), 1269 (m), 1151 (w), 1028(m), 992 (w), 830 (w).  $^1\text{H}$  NMR (400.1 MHz,  $\text{CDCl}_3$ ):  $\delta = 1.28$  (m, 2H, 11-H or 12-H), 1.72 (m, 2H, 11-H or 12-H), 2.09 (m, 2H, 10-H), 3.42 (d, 8-H), 3.71(s, 3H,  $\text{OCH}_3$ ), 4.18(s, 2-H), 4.84 (m, 1H, 4-H), 5.00-5.14 (m, 3H, 14-H + 6-H), 5.57(m, 1H, 5-H), 5.72 (m, 1H, 13-H).  $^{13}\text{C}$  NMR (100.6 MHz,  $\text{CDCl}_3$ , APT):  $\delta = 33.0$  (+, C-11 or C-12), 40.5 (+, C-11 or C-12), 55.6 (–, C-7), 61.5 (+, C-10), 75.9 (–, C-2), 79.9 (–, C-4), 87.0 (–, C-6), 94.9 (–, C-5), 105.9 (+, C-8), 115.6 (+, C-3), 137.6 (–, C-13), 143.3 (+, C-14), 169.8 (+, C-1), 205.9 (+, C-9), 233.1 (+, CO). - MS (70eV,  $90^{\circ}\text{C}$ ):  $m/z$  (%) = 354 (2) [ $\text{M}^+$ ], 298 (2) [ $\text{M} - 2\text{CO}$ ], 270 (7) [ $\text{M} - 3\text{CO}$ ], 246 (100) [ $\text{M} - 3\text{CO} - 2\text{C}$ ], 244 (13), 218 (8), 194 (9), 173 (30), 149 (4), 121 (30), 97 (12), 82 (2), 59 (18), 52 (51) [Cr]. - HRMS ( $\text{C}_{17}\text{H}_{18}\text{CrO}_5$ ): calcd: 354.055939, found: 354.055934.

## 16.6 Anionic Ring Opening and [4+2] Cycloaddition Complex **58** with Acetonitril

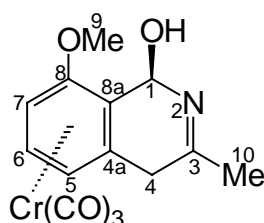

**111**

**GP III**; 2 mL (0.96 mmol) of 0.5 M methyllithium in ether was added to a solution of 250 mg (0.87 mmol) **58** in 40 mL THF at  $-78^{\circ}\text{C}$ , and stirred for 1h. 214 mg (5.2mmol) acetonitril was added and warmed up to  $0^{\circ}\text{C}$  over 4 hours. Hydrolysis with 10 mL of 1M HCl at  $-78^{\circ}\text{C}$ , extraction three times with 30 mL of TBME. Purification by column chromatography (200  $\times$  20 mm, PE, then TBME/PE, 4:1), 238 mg (0.73 mmol, 84%) of 3-Methyl-8-methoxy-1,4-dihydro-isoquinolin-1-ol (**106**) was obtained as a yellow oil.

**106**: IR: (ATR):  $\tilde{\nu}$  = 3422 (br,OH)  $\text{cm}^{-1}$ , 3099(w), 2976(w), 1949 (s, CO), 1846 (s, CO), 1647 (w, N=C), 1538 (m), 1521 (m), 1460 (m), 1410 (m), 1267 (m), 1195 (w), 1151(m), 1072 (m), 1026(m), 992 (w), 872(w), 801(m), 748 (w), 665 (m). -  $^1\text{H}$  NMR (200 MHz,  $\text{CDCl}_3$ ):  $\delta$  = 2.78 (m, 5H, 4-H +  $\text{CH}_3$ ), 3.77 (3H,  $\text{OCH}_3$ ), 4.85 (d, 1H, OH, 4.8 Hz), 5.15 (d, 1H,  $^3J$  = 6.8 Hz, 5-H), 5.41 (d, 1H,  $^3J$  = 6.7 Hz, 7-H), 5.53 (d, 1H,  $^2J_{\text{H,OH}}$  =  $-11.3$  Hz, 1-H), 5.87 (dd, 1H,  $^3J$  = 6.9 Hz,  $^3J$  = 6.4 Hz, 6-H). -  $^{13}\text{C}$  NMR (100.6 MHz,  $\text{CDCl}_3$ , APT):  $\delta$  = 41.6 (+, C-4), 54.8 (-,  $\text{OCH}_3$ ), 67.5 (-,  $\text{CH}_3$ ), 77.3 (-, C-1), 80.4 (-, C-5), 88.5 (-, C-7), 96.0 (-, C-6), 111.3 (+, C-8a), 117.2 (+, C-4a), 143.7 (+, C-8), 144.0 (+, C-3), 233.56 (+, CO). MS (70eV,  $110^{\circ}\text{C}$ ):  $m/z$  (%) = 327(3) [ $\text{M}^+$ ], 243 (11) [ $\text{M} - 3\text{CO}$ ], 191(28), 173(3), 151(5), 121(36), 91(9), 73 (100)

[CH<sub>3</sub>CH=NCH<sub>2</sub>OH], 57 (24), 52 (4) [Cr]. -HRMS (C<sub>14</sub>H<sub>13</sub>CrNO<sub>5</sub>): calcd.: 327.019882; found: 327.019745.

**17 Reduction of 6-methoxybenzocyclobutenedione Complex 42 with Lithium Aluminium Hydride.**

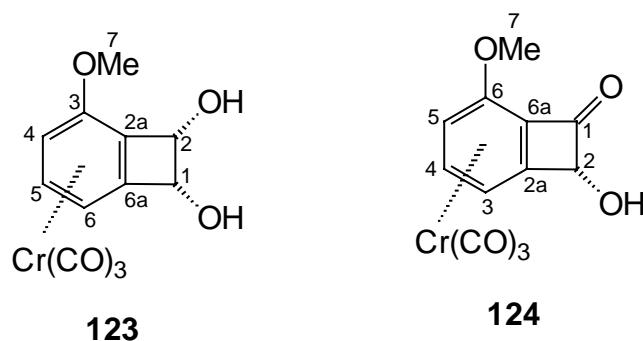

The 286 mg (0.96 mmol) of complex **42** in 50 mL of a 1:1 mixture of THF/Et<sub>2</sub>O at – 78 °C a solution of 12 mg (0.32 mmol) of lithium aluminum hydride in 10 ml THF was added slowly dropwise. The color changed from yellow to orange. After stirring at –78 °C for about 4 h, hydrolysis with 10 mL 1M hydrochloric acid, the mixture was warmed up to 20 °C and diluted with TBME and water. The organic phase was extracted with TBME till the water layer was colorless. The collected organic layers were dried over MgSO<sub>4</sub>, filtered it through a silica gel filled P4-frit and washed with TBME till eluted solution was colorless. The collected organic solvent was evaporated at reduced pressure into a cooled trap. The crude product was purified by column chromatography (200 × 20 mm, PE, then TBME/PE, 2:1). 122 mg (0.4 mmol, 44%) tricarboxyl[η<sup>6</sup>-1,2-*endo*-dihydroxy-6-methoxybenzocyclobutene]-chromium (0) (**123**) as a yellow solid (m.p.108 °C) and 115 mg (0.38 mmol, 40%), tricarboxyl[η<sup>6</sup>-2-*endo*-hydroxy-6-methoxy-1-oxobenzocyclobutene]-chromium (0) (**124**) as an orange-yellow solid (m.p. 92 °C) were obtained.

**123:** IR: (ATR):  $\tilde{\nu}$  = 3349 (br, OH)  $\text{cm}^{-1}$ , 3093 (w), 2957 (w), 2682 (w), 2427 (w), 1951 (s, CO), 1852 (s, CO), 1642 (w), 1531 (m), 1461 (m), 1421 (m), 1392 (m), 1266 (m), 1199 (w), 1160 (w), 1106 (m), 1075 (m), 1039 (m), 1007 (w), 960 (m), 900 (w), 834 (w), 811 (w), 760 (w), 708 (w), 692 (w), 669 (m). -  $^1\text{H}$  NMR (400.1 MHz, acetone- $d_6$ ):  $\delta$  = 3.96 (3H, OCH<sub>3</sub>), 4.52 (br, 2H, 2  $\times$  OH), 5.11 (d, 1H,  $^3J$  = 6.5 Hz, 6-H), 5.16 (d, 1H,  $^3J$  = 5.6 Hz, 4-H), 5.27 (s, 1H, 1-H), 5.35 (s, 1H, 2-H), 5.69 (dd, 1H,  $^3J$  = 6.0 Hz,  $^3J$  = 6.0 Hz, 5-H). -  $^{13}\text{C}$  NMR (100.6 MHz, acetone- $d_6$ , APT):  $\delta$  = 57.1(-, C-7), 71.4 (-, C-1), 71.6 (-, C-2), 77.8 (-, C-6), 80.9 (-, C-5), 95.3 (-, C-4), 104.9 (+, C-2a), 122.2 (+, C-6a), 139.8 (+, C-3), 233.2 (+, CO). - MS (70eV, 100°C):  $m/z$  (%) = 302 (48) [ $\text{M}^+$ ], 246 (25) [ $\text{M} - 2\text{CO}$ ], 218 (100) [ $\text{M} - 3\text{CO}$ ], 200 (35), 176 (2), 157 (7), 132 (58), 105 (9), 90 (5), 77 (8), 52 (35) [Cr]. - HRMS ( $\text{C}_{12}\text{H}_{10}\text{CrO}_6$ ): calcd.: 301.988248; found: 301.987091: Calcd. C 47.79 H 3.33; found: C 46.10 H 3.95.

**124:** IR: (ATR):  $\tilde{\nu}$  = 3409 (br, OH)  $\text{cm}^{-1}$ , 3092 (w), 2962 (w), 1965 (s, CO), 1879 (s, CO), 1765 (s, C=O), 1604 (w), 1531 (m), 2502 (w), 1483 (m), 1462 (m), 1422 (m), 1260 (s), 1188 (w), 1161 (w), 1088 (s), 1032 (s), 1010 (s), 928 (w), 866 (w), 791 (s), 684 (w), 660 (m). -  $^1\text{H}$  NMR (400.1 MHz, acetone- $d_6$ ):  $\delta$  = 3.98 (s, 1H, 2-H), 4.03 (3H, OCH<sub>3</sub>), 5.29 (d, 1H,  $^3J$  = 6.6 Hz, 3-H), 5.57 (d, 1H,  $^3J$  = 6.0 Hz, 5-H), 6.01 (s, 1H, OH), 6.05 (dd, 1H,  $^3J$  = 6.4 Hz,  $^3J$  = 6.3 Hz, 5-H). -  $^{13}\text{C}$  NMR (100.6 MHz, acetone- $d_6$ , APT):  $\delta$  = 59.3 (-, C-7), 78.1 (-, C-3), 80.7 (-, C-4), 83.7 (-, C-2), 92.3 (+, C-6a), 96.7 (-, C-5), 125.8 (+, C-2a), 139.7 (+, C-6), 183.8 (+, C-1), 231.0 (+, CO). - MS (70eV, 100°C):  $m/z$  (%) = 300 (78) [ $\text{M}^+$ ], 244 (29) [ $\text{M} - 2\text{CO}$ ], 216 (100) [ $\text{M} - 3\text{CO}$ ], 198 (10), 173 (35), 155 (5), 136 (2), 119 (5), 91 (5), 73 (13), 52 (86) [Cr]. - CHN analysis  $\text{C}_{16}\text{H}_{14}\text{CrO}_6$  (330.19): calcd. C 48.01, H 2.69; found C 48.67, H 3.68.

## 18 Selective Hydrolysis of Bisacetal Complex 56

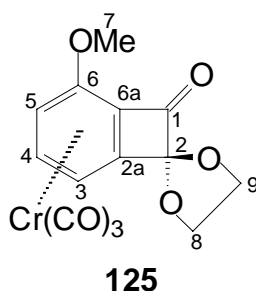

50 mL of 50% hydrochloric acid was added to a solution of 250 mg (0.65 mmol) of bis-acetal complex **56** in 20 mL dichloromethane and cooled at 0°C. The mixture stirred for 2 h at 20°C in dark, the color changed from yellow to red. The aqueous layer was extracted three times with 25 mL of dichloromethane till the aqueous layer remained colorless. The collected organic layer was washed with water three times. The collected organic layers were dried over MgSO<sub>4</sub>, filtered through silica gel filled P4-frit. The solvent was evaporated under reduced pressure in to a cold trap. The crude product was purified by column chromatography (80 × 20 mm, PE, then TBME/PE, 4:1), 77 mg (0.23 mmol, 35%) of tricarbonyl[η<sup>6</sup>-2-(ethylenedioxy)-6-methoxy-1-oxobenzocyclobutene]chromium (0) (**125**) as an orange solid (m. p. 132 °C) and 87 mg (0.3 mmol, 45%) of **42** were obtained as dark red solid.

**125**: IR: (ATR):  $\tilde{\nu}$  = 3085 (w) cm<sup>-1</sup>, 2980 (w), 1969 (s, CO), 1887 (s, CO), 1776 (s, C=O), 1537 (m), 1460 (m), 1419 (m), 1402 (m), 1283 (m), 1213 (m), 1164 (w), 1049 (m), 1003 (s, C-O), 945 (m), 832 (m), 739 (m), 662 (m). - <sup>1</sup>H NMR (200.1 MHz, acetone-*d*<sub>6</sub>): δ = 4.05 (3H, OCH<sub>3</sub>), 4.28 (m, 4H, CH<sub>2</sub>), 5.38 (d, 1H, <sup>3</sup>J = 6.7 Hz, 3-H), 5.76 (d, 1H, <sup>3</sup>J = 5.9 Hz, 5-H), 6.12 (dd, 1H, <sup>3</sup>J = 6.3 Hz, <sup>3</sup>J = 6.3 Hz, 4-H). - <sup>13</sup>C NMR (100.6 MHz, acetone-*d*<sub>6</sub>, APT): δ = 57.1 (-, C-7), 66.8 (+, C-8 or C-9), 67.3 (+, C-8 or C-9), 78.4 (-, C-3), 80.6 (-, C-5), 97.0 (-, C-4), 95.5 (+, C-2), 119.2 (+, C-6a), 124.0 (+, C-2a), 139.5 (+, C-6), 187.6 (+, C-1), 230.2 (+, CO). MS (70eV, 80°C): *m/z* (%) = 342 (2)

[M<sup>+</sup>], 258 (3) [M – 3CO], 215 (1), 183 (3), 158 (8), 134 (19), 104 (7), 76 (26), 52 (100) [Cr]. -HRMS (C<sub>14</sub>H<sub>10</sub>CrO<sub>7</sub>) : calcd.: 341.977289; found: 341.977264.

### Crystal Structure Analysis of 125:

C<sub>14</sub>H<sub>10</sub>CrO<sub>7</sub>, molecular weight, 342.23: crystal system monoclinic. Space group p 21/n (no. 14),  $a = 12.650(2)$ ,  $b = 7.104(2)$ ,  $c = 15.312(5)$  Å,  $\alpha = 90$ ,  $\beta = 92.74(4)$ ,  $\gamma = 90^\circ$ ,  $V = 1374.4(7)$  Å<sup>3</sup>,  $Z = 4$ ,  $\rho_{\text{calcd.}} = 1.654$  gcm<sup>-3</sup>,  $F(000) = 316e$ ,  $\mu = 8.8$  cm<sup>-1</sup>, crystal: orange needle | | (010), size 0.06 × 0.33 × 0.03 mm, Stoe IPDS (Imaging Plate) diffractometer,  $T = 300$  K, MoK $_{\alpha}$  = 0.71073 Å,  $2\theta_{\text{min}} = 4.1^\circ$ ,  $2\theta_{\text{max}} = 52.1^\circ$ ,  $\Delta\Phi = 1.5^\circ$ , 12320 measured reflections ( $\pm 15$ ,  $\pm 8$ ,  $\pm 18$ ), 2699 independent [ $R(I)_{\text{int}} = 0.216$ ] and 719 observed reflection [ $I_t > 2.0 \sigma(I)$ ], completeness of data: 99.9 %, no absorption correction, no extinction correction, structure solution with direct methods with SHELXS-86, refinement with SHELXL-93, hydrogen atoms in geometrically calculated positions,  $N_{\text{ref}} = 2699$ ,  $N_{\text{par}} = 199$ ,  $R = 0.0289$ ,  $R_w = 0.0654$  [ $w = 1/\sigma^2(F_o^2)$ ],  $S = 0.45$ , minimal and maximal residual electron density – 0.16/0.22 eÅ<sup>-3</sup>.

### 18.1 Treatment of 42 with one equivalent of vinylmagnesiumbromide addition

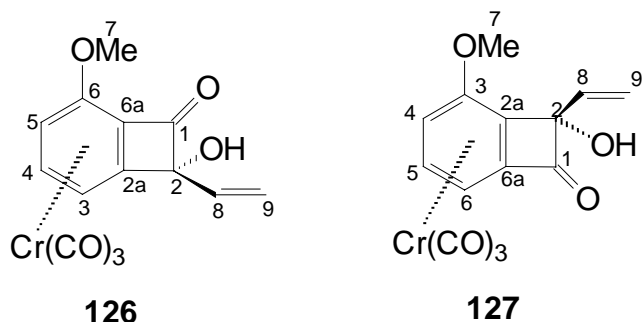

1.0 mL (1.00 mmol) of 0.9 M vinylmagnesiumbromide<sup>117</sup> in diethyl ether was added slowly to a solution of 300 mg (1.00 mmol) 10 ml Et<sub>2</sub>O at –78°C. After stirring at –78 °C for about 5 h, hydrolysis with 10 mL 1M hydrochloric acid,

the mixture was warmed up to 20 °C and diluted with TBME and water. The organic phase was extracted three times with 20 mL of TBME till the water layer remained colorless. The collected organic layers were dried over MgSO<sub>4</sub>, filtered it through a silica gel filled P4-frit and washed with TBME till eluted solution was colorless. The collected organic solvent was evaporated at reduced pressure into a cooled trap. The crude product was purified by column chromatography (200 × 20 mm, PE, then TBME/PE, 1:1). 267 mg (0.82 mmol, 82 %) of mixture of tricarbonyl[η<sup>6</sup>-2-*endo*-hydroxy-6-methoxy-1-oxo-vinylbenzocyclobutene]chromium (0) (**126**) and tricarbonyl[η<sup>6</sup>-2-*endo*-hydroxy-3-methoxy-1-oxo-vinylbenzocyclobutene]-chromium (0) (**127**) were obtained as a yellow solid (m.p.133 °C). <sup>1</sup>H NMR and <sup>13</sup>C NMR indicated the ration **126/127** = 3:1.

**126:** Identified spectroscopically.<sup>99</sup>

The only differences <sup>1</sup>H NMR and <sup>13</sup>C NMR spectra of **127** than **126** are as follows:

**127:** - <sup>1</sup>H NMR (200.1 MHz, acetone-*d*<sub>6</sub>): δ = 3.96 (3H, OCH<sub>3</sub>), 5.91 (dd, 1H, <sup>3</sup>*J* = 6.3 Hz, <sup>3</sup>*J* = 6.4 Hz, 5-H), (*all other signals are overlapped and could not be distinguished*). - <sup>13</sup>C NMR (100.6 MHz, acetone-*d*<sub>6</sub>, APT): δ = 57.7 (–, C-7), 79.2 (–, C-6), 80.1 (–, C-5), 95.1(+, C-2), 95.7 (–, C-4), 105.5(+, C-6a), 117.7 (+, C-2a), 128.2 (+, C-9), 136.3 (–, C-8), 139.4 (+, C-3), 188.7 (+, C-1), 231.2 (+, CO).



**19 General Procedure for the single Nucleophilic Addition to 2-endo-hydroxy-2-exo-Vinyl-6-methoxybenzocyclobutenone Complex 143 and Dianionic Oxy-Cope Rearrangement Followed by Selective Intramolecular Aldol Addition (GP IV)**

A solution of complex **126** in THF/Et<sub>2</sub>O 1:1 was cooled at  $-78\text{ }^{\circ}\text{C}$ . A solution of the nucleophile in THF was added to the solution of **126** slowly so that the temperature remains  $-78\text{ }^{\circ}\text{C}$ . The color of the reaction mixture changed from red-brown to orange. The mixture was stirred for about 5 to 16 h at  $-78\text{ }^{\circ}\text{C}$  till no starting material was detectable by TLC. After completion of the reaction it was hydrolyzed either by addition of saturated aqueous NH<sub>4</sub>Cl or 1M HCl at  $-78\text{ }^{\circ}\text{C}$ . The reaction was allowed to warm up to  $20\text{ }^{\circ}\text{C}$ , and extracted with the organic solvent. The aqueous layers was extracted with TBME or ethyl acetate till the aqueous layer remained colorless. The collected organic layers were dried over MgSO<sub>4</sub>, filtered through silica gel filled P4-frit and washed with TBME or ethyl acetate till the eluted solvent was colorless. The collected organic solvent was evaporated at reduced pressure in to a cold trap. The crude product was purified by flash chromatography eluted first with pure petrol ether, then with mixture polar solvent and petrol ether. The solvent was evaporated at reduced pressure and dried by keeping it in the vacuum overnight.

## 19.1 Nucleophilic Addition to 2-endo-hydroxy-2-exo-vinyl-6-methoxybenzo-cyclobutenone complex **126**

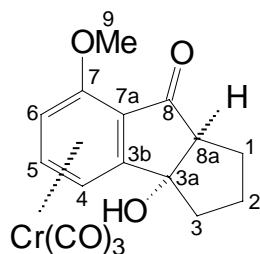

**128**

**GP IV**; 3.5 mL (3.07 mmol) of 0.9 M vinyl lithium in Et<sub>2</sub>O, 250 mg (0.77 mmol) of **126** in 80 mL of THF/ Et<sub>2</sub>O (1:1) at -78 °C; stirring for 16 h at -78 °C, hydrolysis with 10 mL of saturated aqueous NH<sub>4</sub>Cl, extraction with three times with 30 mL of TBME. Purification by column chromatography (200 × 20 mm, PE, then TBME/PE, 6:1), 195 mg (0.55 mmol, 72%) of tricarbonyl[η<sup>6</sup>-(endo-8a),1,2,3-tetrahydro-3a-endo-hydroxy-7-methoxy-cyclopenta[α]inden-8-on]chromium (0) **128** was obtained as an orange solid (m.p. 140° C).

**128**: IR: (ATR):  $\tilde{\nu}$  = 3399 (br, OH) cm<sup>-1</sup>, 2963 (w), 1962 (s), 1873 (s), 1703 (s, C = O), 1597 (w), 1524 (m), 1458 (m), 1429 (m), 1406 (w), 1260 (s), 1203 (m), 1021 (s), 875 (w), 798 (s), 721 (w), 702 (w), 662 (m). - <sup>1</sup>H NMR (200.1 MHz, CDCl<sub>3</sub>):  $\delta$  = 1.54 (m, 1-H), 1.93- 1.98 (m, 4H, 1-H + 3-H + 2-H), 2.22 (m, 1H, 1-H), 2.99 (dd, 1H, <sup>3</sup>J<sub>endo-8a,endo-1</sub> = 7.2 Hz, <sup>3</sup>J<sub>endo-8a,exo-1</sub> = 2.8 Hz, 8a-H), 3.85 (3H, OCH<sub>3</sub>), 5.04 (s, 1H, OH). 5.47 (2d, 2H, <sup>3</sup>J = 6.7 Hz, <sup>3</sup>J = 5.8 Hz, 4-H + 6-H), 6.18 (dd, 1H, <sup>3</sup>J = 6.3 Hz, <sup>3</sup>J = 6.4 Hz, 5-H). - <sup>13</sup>C NMR (100.6 MHz, acetone-*d*<sub>6</sub>, APT):  $\delta$  = 25.6 (+, C-2), 28.0 (+, C-1), 43.6 (+, C-3), 55.5 (-, C-9), 60.1 (-, C-8a), 73.9 (-, C-4), 80.6 (-, C-6), 82.8 (+, C-7a), 86.4 (+, C-3a), 96.4 (-, C-5), 131.3 (+, C-3b), 141.8 (+, C-7), 199.8 (+, C-8), 231.4 (+, CO). - MS (70eV, 130°C): *m/z* (%) = 354 (17) [M<sup>+</sup>], 298 (11) [M - 2CO], 270 (78) [M - 3CO], 255 (100)[M - Cr(CO)<sub>3</sub> CH<sub>3</sub>], 237 (18), 218 (11), 189 (11), 171 (4),

152 (14), 125 (12), 91 (18), 69 (26), 52 (16) [Cr]. - HRMS (C<sub>16</sub>H<sub>14</sub>CrO<sub>6</sub>): calcd. 354.018768, found. 354.019548; calcd.: C 54.24, H 3.98; found: C 54.62, H 4.19.

## 19.2 Addition of 1-Cyclopentenyllithium to the mixture of 126 and 127 (3:1)

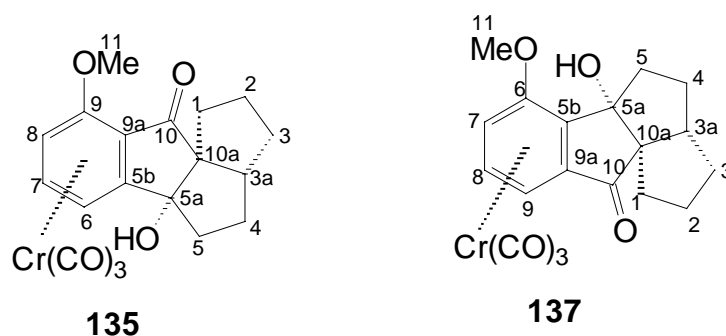

**GP IV**; 394 mg (2.68 mmol) of 1-bromocyclopentene in 10 mL diethyl ether and 25 mg (3.2 mmol) of lithium sand in 10 mL of diethyl ether were heated at reflux for 1 h.<sup>110</sup> Cooling to  $-78\text{ }^{\circ}\text{C}$ , a solution of 200 mg (0.61 mmol) of mixture of **126/127** in 60 mL of THF/ Et<sub>2</sub>O were added dropwise. Stirring 16 h at  $-78\text{ }^{\circ}\text{C}$ , hydrolysis with 10 mL of 1M hydrochloric acid, extraction three times with 25 mL of TBME. Purification by column chromatography (200 × 20 mm, PE, then TBME/PE, 6:1), 150 mg (0.38 mmol, 62%) of tricarbonyl[η<sup>6</sup>-endo[1,2,3],3a,4,5-hexahydro-5a-endo-hydroxy-9-methoxy-cyclopenta[α]-inden-10-on]chromium (0) (**135**) as orange solid (m. p. 181 °C) and 58 mg (0.15 mmol, 24%) of tricarbonyl[η<sup>6</sup>-endo-[1,2,3],3a,4,5-hexahydro-5a-endo-hydroxy-6-methoxycyclopenta[α]inden-10-on]chromium (0) (**137**) as an orange solid (m. p. 178 °C) were obtained.

**135**: IR: (ATR):  $\tilde{\nu} = 3459$  (br, OH) cm<sup>-1</sup>, 2952 (w), 1974 (s, CO), 1887 (s, CO), 1693 (s, C = O), 1525 (m), 1460 (m), 1429 (w), 1408 (w), 1316 (w), 1278 (s), 1097 (m), 1039 (m), 918 (w) 856 (w), 803 (m), 751 (w), 683 (w), 625

(m), 528 (w), 479 (w). -  $^1\text{H}$  NMR (400.1 MHz, acetone- $d_6$ ):  $\delta$  = 1.56 (m, 1H, aliph.-H), 1.67 (m, 2H, aliph.-H), 1.77 (m, 3H, aliph.-H), 1.86 (m, 2H, aliph.-H), 2.30 (m, 1H,  $^3J_{\text{exo-3a,exo-3}} = 4.3$  Hz,  $^3J_{\text{exo-3a,endo-3}} = 2.0$  Hz,  $^3J_{\text{exo-3a,exo-4}} = 6.6$  Hz,  $^3J_{\text{exo-3a,endo-4}} = 3.5$  Hz, 3a-H), 2.5 (m, 2H, aliph.-H), 3.80 (3H, OCH<sub>3</sub>), 4.85 (s, 1H, OH). 5.46 (d, 1H,  $^3J = 6.8$  Hz, 6-H), 5.48 (d, 1H,  $^3J = 6.3$  Hz, 7-H), 6.11 (dd, 1H,  $^3J = 6.4$  Hz,  $^3J = 6.5$  Hz, 8-H). -  $^{13}\text{C}$  NMR (100.6 MHz, acetone- $d_6$ , APT):  $\delta$  = 26.9 (+, C-2), 31.7 (+, C-1), 32.6 (+, C-3), 33.8 (+, C-4), 44.4 (+, C-5), 51.2 (-, C-3a), 55.5 (-, C-11), 71.3 (+, C-10a), 74.2 (-, C-6), 80.7 (-, C-7), 83.6 (+, C-5a), 85.8 (+, C-9a), 96.1 (-, C-8), 130.8 (-, C-5b), 141.2 (+, C-9), 204.2 (+, C-10), 231.6 (+, CO). - MS (70eV, 130°C):  $m/z$  (%) = 395 (15) [ $\text{M}^+$ ], 339 (9) [ $\text{M} - 2\text{CO}$ ], 311 (100) [ $\text{M} - 3\text{CO}$ ], 295 (77), 258 (3), 240 (6), 217 (4), 155 (2), 52 (8) [Cr] -HRMS ( $\text{C}_{19}\text{H}_{18}\text{CrO}_6$ ): cal. 394.050873, found. 394.050848; calcd. C 57.87 H 4.60, found C 57.21 H 4.5

### Crystal Structure Analysis of 135:

$\text{C}_{19}\text{H}_{18}\text{CrO}_6$ , molecular weight, 394.33: crystal system monoclinic. Space group  $p\ 2_1/n$  (no. 14),  $a = 15.434(5)$ ,  $b = 13.562(2)$ ,  $c = 17.128(4)$  Å,  $\alpha = 90$ ,  $\beta = 96.85(3)$ ,  $\gamma = 90^\circ$ ,  $V = 3560(2)$  Å<sup>3</sup>,  $Z = 8$ ,  $d_{\text{calcd.}} = 1.472$  gcm<sup>-3</sup>,  $F(000) = 1632e$ ,  $\mu = 0.675$  cm<sup>-1</sup>, crystal: red plate | | (100), size 0.30 × 0.06 × 0.03 mm, Stoe IPDS (Imaging Plate) diffractometer,  $T = 300(2)$  K,  $\text{MoK}_\alpha = 0.71073$  Å,  $2\theta_{\text{min}} = 2.01^\circ$ ,  $2\theta_{\text{max}} = 26.14^\circ$ ,  $\Delta\Phi = 1.5^\circ$ , 37542 measured reflections ( $\pm 18$ ,  $\pm 15$ ,  $\pm 21$ ), 6774 independent [ $R(I)_{\text{int}} = 0.5982$ ] and 279 observed reflection [ $I_t > 2\sigma(I)$ ], completeness of data: 96.7 %, no absorption correction, no extinction correction, structure solution with direct methods with SHELXS-86, refinement with SHELXL-93, hydrogen atoms in geometrically calculated positions,  $N_{\text{ref}} = 6774$ ,  $N_{\text{par}} = 279$ , final [ $I > 2\sigma(I)$ ]  $R = 0.0551$ ,  $R_w = 0.0823$  [ $w = 1/\sigma^2(F_o^2)$ ], and all data  $R = 0.3426$ ,  $R_w = 0.1344$  [ $w = 1/\sigma^2(F_o^2)$ ]  $S = 0.45$ , minimal and maximal residual electron density – 0.16/0.22 eÅ<sup>-3</sup>.

**137:** IR: (ATR):  $\tilde{\nu} = 3450$  (br, OH)  $\text{cm}^{-1}$ , 2962 (w), 1974 (s, CO), 1915 (s, CO), 1883 (s, CO), 1716 (s, C = O), 1525 (m), 1460 (m), 1429 (w), 1320 (w), 1262 (s), 1099 (s), 1057 (s), 1017 (s), 918 (w), 854 (w), 801 (m), 660 (w), 616 (m), 528 (w), 469 (w). -  $^1\text{H}$  NMR (400.1 MHz, acetone- $d_6$ ):  $\delta = 1.76 - 1.78$  (m, 6H, aliph.-H), 1.98- 2.01(m, 2H, aliph.-H), 2.31- 2.35 (m, 2H, aliph.-H), 2.52- 2.56 (m, 1H,  $^3J_{\text{exo-3a, exo-3 or 4}} = 4.0$  Hz,  $^3J_{\text{exo-3a, endo-3 or 4}} = 2.6$  Hz, 3a-H), 3.87 (3H, OCH<sub>3</sub>), 4.29 (s, 1H, OH). 5.30 (d, 1H,  $^3J = 5.9$  Hz, 9-H), 5.71 (d, 1H,  $^3J = 6.6$  Hz, 7-H), 5.86 (t, 1H, H,  $^3J = 6.4$  Hz,  $^3J = 6.5$  Hz, 8-H). -  $^{13}\text{C}$  NMR (100.6 MHz, acetone- $d_6$ , APT):  $\delta = 26.7$  (+, C-2), 31.6 (+, C-1), 32.7 (+, C-3), 34.5 (+, C-4), 41.0 (+, C-5), 50.6 (-, C-3a), 55.9 (-, C-11), 71.4 (+, C-10a), 76.9 (+, C-9), 79.7 (-, C-8), 84.0 (+, C-5a), 96.1 (-, C-7), 98.7 (+, C-9a), 114.8 (+, C-5b), 139.4 (+, C-6), 207.8 (+, C-10), 231.9 (+, CO). - MS (70eV, 130°C):  $m/z$  (%) = 395 (15)[M<sup>+</sup>], 339 (12) [M - 2CO], 310 (100) [M - 3CO], 292 (15), 264 (7), 247 (2), 225 (14), 197 (2), 161 (2), 79 (2), 52 (11) [Cr]. -HRMS (C<sub>19</sub>H<sub>18</sub>CrO<sub>6</sub>): calcd. 394.050848; found. 394.050568; calcd. C 57.87 H 4.60, found C 58.40 H 4.34

### Crystal Structure Analysis of 137:

C<sub>19</sub>H<sub>18</sub>CrO<sub>6</sub>, molecular weight, 394.34: crystal system monoclinic. Space group p 21/n (no. 14),  $a = 9.706(2)$ ,  $b = 13.710(2)$ ,  $c = 13.511(3)$  Å,  $\alpha = 90$ ,  $\beta = 107.30(3)$ ,  $\gamma = 90^\circ$ ,  $V = 1716.6(6)$  Å<sup>3</sup>,  $Z = 4$ ,  $d_{\text{calcd.}} = 1.526$  gcm<sup>-3</sup>,  $F(000) = 816e$ ,  $\mu = 7.0$  cm<sup>-1</sup>, crystal: red plate | | (100), size 0.03 × 0.20 × 0.09 mm, Stoe IPDS (Imaging Plate) diffractometer,  $T = 300$  K, MoK $_{\alpha}$  = 0.71073 Å,  $2\theta_{\text{min}} = 4.4^\circ$ ,  $2\theta_{\text{max}} = 52.2^\circ$ , scan type 134 exposure,  $\Delta\Phi = 1.5^\circ$ , 13711 measured reflections ( $\pm 11$ ,  $\pm 16$ ,  $\pm 16$ ), 3364 independent [ $R(I)_{\text{int}} = 0.134$ ] and 1142 observed reflection [ $I_t > 2.0 \sigma(I)$ ], completeness of data: 99.8%, no absorption correction, no extinction correction, structure solution with direct methods with SHELXS-86, refinement with SHELXL-93, hydrogen atoms in geometrically calculated positions,  $N_{\text{ref}} = 3364$ ,  $N_{\text{par}} = 140$ ,  $R = 0.0388$ ,  $R_w =$

0.0654 [ $w = 1/\sigma^2 (F_o^2)$ ],  $S = 0.58$ . minimal and maximal residual electron density – 0.00/0.00  $e\text{\AA}^{-3}$ .

### 19.3 Addition of 2-Propenyllithium to the Pure Complex 126

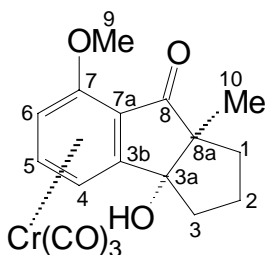

**141**

**GP IV**; 222 mg (1.84 mmol) of 2-bromopropene in 25 mL of diethyl ether and 20 mg (2.85 mmol) of lithium sand in 10 ml of diethyl ether heating at reflux for 1 h.<sup>110</sup> To the cooled lithiated solution at  $-78\text{ }^\circ\text{C}$ , 150 mg (0.46 mmol) of **126** in 60 mL of THF/Et<sub>2</sub>O (1:1) was added dropwise. Stirring for 16 h at  $-78\text{ }^\circ\text{C}$ , hydrolysis with 10 mL of 1M hydrochloric acid, extraction three times with 20 mL of TBME. Purification by column chromatography (200 × 20 mm, PE, then TBME/PE, 2:1), 171 mg (0.46 mmol, 76%) of tricarbonyl[ $\eta^6$ -1,2,3-trihydro-3a-endo-hydroxy-8a-endo-methyl-7-methoxy-cyclopenta[ $\alpha$ ]inden-8-on]chromium (0) (**141**) was obtained as an orange-red solid (m.p.  $148\text{ }^\circ\text{C}$ ).

**141**: IR: (ATR):  $\tilde{\nu}$  ( $\text{cm}^{-1}$ ) = 3403 (br, OH), 2963 (w), 1975 (s, CO), 1905 (s, CO), 1874 (s, CO), 1686 (s, C = O), 1596 (w), 1514 (m), 1456 (m), 1429 (w), 1406 (w), 1259 (s), 1230 (m), 1193 (m), 1089 (s), 1054 (s) 871 (w), 796 (s), 770 (w), 700 (w), 657 (m). - <sup>1</sup>H NMR (400.1 MHz, acetone-*d*<sub>6</sub>):  $\delta$  = 1.13 (m, 2H, 1-H or 2-H or 3-H), 1.34 (s, 3H, CH<sub>3</sub>), 1.65 (m, 2H, 1-H or 2-H or 3-H), 2.27 (m, 2H, 1-H or 2-H or 3-H), 3.80 (3H, OCH<sub>3</sub>), 4.88 (s, 1H, OH). 5.46 (d, 1H, <sup>3</sup>*J* = 6.6 Hz, 4-H), 5.52 (d, 1H, <sup>3</sup>*J* = 6.3 Hz, 6-H), 6.13 (dd, 1H, <sup>3</sup>*J* = 6.5 Hz, <sup>3</sup>*J* = 6.5 Hz, 5-H). - <sup>13</sup>C NMR (100.6 MHz, acetone-*d*<sub>6</sub>, APT):  $\delta$  = 20.0 (–,

CH<sub>3</sub>), 22.3 (+, C-2), 29.1 (+, C-3), 29.3 (+, C-1), 39.0 (+, C-8a), 44.29 (+, C-3a), 55.4 (-, C-9), 59.0 (+, C-7a), 74.3 (-, C-4), 80.9 (-, C-6), 82.6 (+, C-3b), 96.3 (-, C-6), 140.3 (+, C-7), 204.8 (+, C-8), 231.4 (+, CO). - MS (70eV, 160°C): *m/z* (%) = 368 (17) [M<sup>+</sup>], 312 (11) [M - 2CO], 284 (6) [M - 3CO], 269 (100) [M - 3CO-CH<sub>3</sub>], 251 (6), 232 (14), 215 (4), 190 (6), 161 (7), 142 (6), 91 (12), 69 (35), 52 (35) [Cr] - CHN analysis (C<sub>17</sub>H<sub>15</sub>O<sub>6</sub>Cr) 367.2779: calcd. C 55.54, 4.36; found. C 56.57, H 4.60.

## **20 General Procedure for double Nucleophilic Addition to 6-Methoxy-benzocyclobutendione Complex **42** and Dianionic Oxy-Cope Rearrangement Followed by Intramolecular Aldol Addition (GP V)**

A solution of 8 equivalents of nucleophile in THF is added to a -78 °C cold solution of **42** in THF/Et<sub>2</sub>O (1:1) slowly so that the temperature remains -78°C. The color of reaction mixture changes from red-brown to orange. The mixture is stirred for about 5 - 16 h at -78°C till no starting material can be detected by TLC. After completion of reaction mixture, hydrolysis by addition of either saturated aqueous NH<sub>4</sub>Cl or 1M HCl at -78°C. The mixture allow to warm up to 20°C, and extracted aqueous layer three times with TBME or ethyl acetate till the water layer remained colorless. The collected organic layers are dried over MgSO<sub>4</sub>, filtered through silica gel filled P4-frit and washed with TBME or ethyl acetate till the eluent is colorless. The organic solvent is evaporated at reduced pressure into a cold trap. The crude product was purified by column chromatography (SiO<sub>2</sub>, 200 × 20 mm, eluted first with PE, then with mixture polar solvent and petrol ether). The solvent is evaporated at reduce pressure and the residue is put under vaccum for 24 h.

## 20.1 Addition of 2-Propenyllithium to Complex **42**

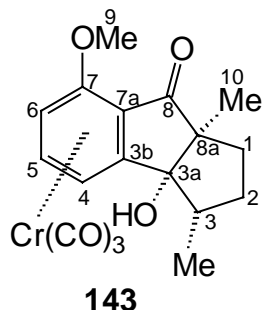

**GP V**; 486 mg (4.0 mmol) of 2-bromopropene in 25 mL diethyl ether and 40 mg (5.7 mmol) of lithium sand in 10 mL diethyl ether heating at reflux for 1 h.<sup>110</sup> The mixture was cooled at  $-78^{\circ}\text{C}$ , and to the cooled lithiated solution 150 mg (0.5 mmol) of **42** in 50 mL of 1:1 THF/diethyl ether (1:1) was added dropwise. Stirring for 16 h at  $-78^{\circ}\text{C}$ , hydrolysis with 10 mL of 1M hydrochloric acid, extraction three times with 25 mL TBME, purification by column chromatography (200  $\times$  20 mm, PE, then TBME/PE, 6:1), 142 mg (0.4 mmol, 74%) of Tricarbonyl[ $\eta^6$ -1,2,3,3a-tetrahydro-3a-*endo*-hydroxy-3,8a-di-*endo*-methylcyclopenta[ $\alpha$ ]ind-en-8-on]-chromium (0) (**143**) was obtained as an orange solid (m.p.  $151^{\circ}\text{C}$ ).

**143**: IR: (ATR):  $\tilde{\nu}$  = 3410 (br, OH)  $\text{cm}^{-1}$ , 2951 (w), 2871 (w), 1969 (s, CO), 1900 (s, CO), 1878 (s, CO), 1686 (s, C=O), 1515 (m), 1456 (m), 1454 (m), 1427 (w), 1404 (w), 1337 (w), 1329 (w), 1258 (s), 1202 (m), 1073 (s, C-O), 1035 (s), 999 (s) 964 (m), 799 (s), 769 (w), 702 (w), 656 (m). -  $^1\text{H}$  NMR (400.1 MHz, acetone- $d_6$ ):  $\delta$  = 1.16 (d, 3H, 3- $\text{CH}_3$ ,  $^2J$  = 6.9 Hz), 1.44(s, 3H, 8a- $\text{CH}_3$ ), 1.68 (m, 2H, 2-H), 1.71 (m, 1H, 1-H), 1.88 (m, 1H, 1-H), 1.99 (dd, 3H,  $^3J_{\text{cis}3,2}$  = 6.9 Hz,  $^3J_{\text{trans}3,2}$  = 2.4 Hz, 3-H), 3.80 (3H,  $\text{OCH}_3$ ), 4.50 (s, 1H, OH). 5.47 (d, 1H,  $^3J$  = 6.8 Hz, 4-H), 5.51 (d, 1H,  $^3J$  = 6.3 Hz, 6-H), 6.12 (dd, 1H,  $^3J$  = 6.5 Hz,  $^3J$  = 6.5 Hz, 5-H). -  $^{13}\text{C}$  NMR (100.6 MHz, acetone- $d_6$ ):  $\delta$  = 12.0 (–, 3- $\text{CH}_3$ ), 22.0 (–, 8a- $\text{CH}_3$ ), 32.0 (+, C-1), 35.8 (+, C-2), 48.5 (–, C-3), 55.4 (–,



C-9), 60.7 (+, C-8a), 74.5 (–, C-4), 80.2 (–, C-5), 83.5 (+, C-3a), 85.1 (+, C-7a), 96.0 (–, C-6), 130.3 (+, C-3b), 140.7 (+, C-7), 204.8 (+, C-8), 231.4 (+, CO). - MS (70eV, 100°C):  $m/z$  (%) 382 (23) [ $M^+$ ], 326 (13) [ $M - 2CO$ ], 298 (99) [ $M - CO$ ], 283 (100), 256 (32), 227 (7), 203 (5), 183 (6), 149 (5), 115 (5), 91 (5), 73 (5), 52 (16) [Cr]. -HRMS ( $C_{18}H_{18}O_6Cr$ ): calcd. 382.050842; found. 382.050848. CHN anal. (382.3302): calcd. C 56.54, H 4.75; found C 56.29, H 4.76.

## 20.2 Addition of 1-Ethoxy-1-lithioethene to Complex **42**

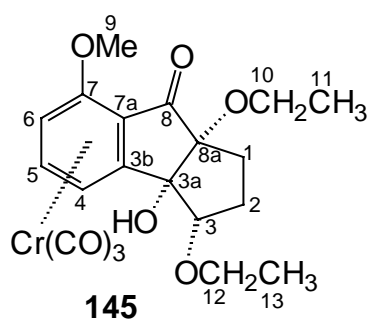

**GP V**; 289 mg (4.0 mmol) of 1-ethoxyethene in 10 ml THF, 1.5 mL (2.2 mmol) of 1.6 M *tert*-Butyllithium in pentane, warming up to  $-5^{\circ}C$ , stirring at that temperature for about 45 min.<sup>126</sup> The mixture was cooled to  $-78^{\circ}C$ , and to the cooled lithiated solution, 150 mg (0.5 mmol) of **42** in 50 mL THF/diethyl ether (1:1) was added dropwise. Stirring for 16 h at  $-78^{\circ}C$ , hydrolyzed with 10 mL of 1M hydrochloric acid, extracted three times with 20 mL of TBME, column chromatography (200 × 20 mm, PE, then TBME/PE, 4:1), 148 mg (0.3 mmol, 67%) of Tricarbonyl[ $\eta^6$ -3,8a-diethoxy-3a-endo-hydroxy-7-methoxy-2,3,3a,8a-tetrahydro-1*H*-cyclopenta[ $\alpha$ ]inden-8-on]-chromium(0) (**145**) was obtained as an orange solid (m.p.  $134^{\circ}C$ ).

**145**: IR: (ATR):  $\tilde{\nu} = 3400$  (br, OH)  $cm^{-1}$ , 3097 (w), 2965 (w), 1961 (s, CO), 1871 (s, CO), 1710 (s, C=O), 1596 (w), 1514 (m), 1459 (m), 1426 (m),

1357(w), 1263 (s), 1235 (w), 1162 (w), 1045 (s), 957 (m), 800 (m), 722 (w), 657 (m). -  $^1\text{H}$  NMR (400.1 MHz, acetone- $d_6$ ):  $\delta$  = 1.18 (t, 6H,  $^3J$  = 7.0 Hz,  $^3J$  = 6.9 Hz, 11-H + 13-H), 2.22 (m, 2H, 2-H), 2.54 (m, 2H, 1-H), 3.63 (dd, 1H,  $^3J_{exo-3, endo-2}$  = 2.0 Hz,  $^3J_{exo-3, exo-2}$  = 7.0 Hz) 3.80 (3H, OCH<sub>3</sub>), 3.91(m, 4H, 10H + 12-H), 4.65(m, OH), 5.54 (d, 1H,  $^3J$  = 6.3 Hz, 4-H), 5.69 (d, 1H,  $^3J$  = 6.9 Hz, 6-H), 6.12(dd, 1H,  $^3J$  = 6.5 Hz,  $^3J$  = 6.6 Hz, 5-H). -  $^{13}\text{C}$  NMR (100.6 MHz, acetone- $d_6$ , APT):  $\delta$  = 25.2 (-, C-13 or C-11), 25.8 (-, C-13 or C-11), 26.1 (+, C-1 or C-2), 27.2 (+, C-2 or C-1), 38.5 (+, C-3a), 47.9 (-, C-3), 55.6(-, C-9), 65.6 (+, C-10 or C-12), 65.9 (+, C-10 or C-12), 75.9 (-, C-4), 76.1 (+, C-7a), 83.5 (-, 6-C), 94.7(-, C-5), 96.9 (+, C-3b), 139.6 (+, C-7), 197.9 (+, C-8), 232.1 (+, CO). - MS (70eV, 210°C):  $m/z$  (%) = 414 (2) [M - CO], 386 (3) [M - 2CO], 358 (10) [M - 3CO], 322 (35), 286 (19), 254 (12), 226 (15), 189 (11), 159 (12), 136 (100), [C<sub>6</sub>H<sub>4</sub>OCH<sub>3</sub>C<sub>2</sub>H<sub>5</sub>], 109 (25), 91 (21), 73 (34), 52 (11)[Cr]. - HRMS (C<sub>20</sub>H<sub>22</sub>O<sub>8</sub>Cr): calcd. 442.071978, found 442.073395.

### 20.3 Additions of 1-Lithio-1-methoxyallene to complex **42**

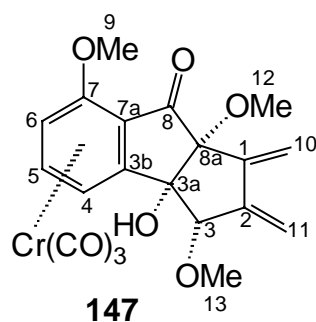

**GP V**; 2.5 mL (3.9 mmol) of 1.6 M butyllithium in hexane was added to 281 mg (4.0 mmol) of 1-methoxyallene in 15 mL diethyl ether at  $-78^\circ\text{C}$  and warmed up to  $-30^\circ\text{C}$  over 45 min.<sup>127</sup> To the solution 150 mg (0.5 mmol) of **42** in 70 mL of THF/diethyl ether (1:1) at  $-78^\circ\text{C}$ , after stirring 16 h, hydrolysis with 10 mL of 1M hydrochloric acid, extracted three times with 25 mL of TBME, column chromatography (200  $\times$  20 mm, PE, then TBME/PE, 6:1), 129 mg (0.3 mmol, 59%) of Tricarbonyl[ $\eta^6$ -3a-endo-hydroxy-3,8a-endo-dimethoxy-1,2-

dimethylen-1,2,3a,8,8a-hexahydro-7-methoxycyclopenta[ $\alpha$ ]inden-8-on)-chromium(0) (**147**) was obtained as an orange-red solid (m. p.135°C).

**147**: IR: (ATR):  $\tilde{\nu}$  = 3469 (br, OH)  $\text{cm}^{-1}$ , 2964 (m), 1961 (s, CO), 1877 (s, CO), 1714 (s, C=O), 1664 (s), 1595 (w), 1519 (m), 1454 (w), 1429 (w), 1371 (w), 1259 (s), 1169 (w), 1012 (s), 957 (m), 935 (m), 879 (w), 796 (s), 697 (w), 659 (m). -  $^1\text{H}$  NMR (400.1 MHz, acetone- $d_6$ ):  $\delta$  = 3.46 (3H, OCH<sub>3</sub>), 3.74 (3H, OCH<sub>3</sub>), 3.95 (3H, OCH<sub>3</sub>), 4.70 (s, OH), 5.45 (d, 1H,  $^2J$  = 6.0 Hz, =CH), 5.53 (d, 1H,  $^3J$  = 6.4 Hz, 4-H), 5.57 (d, 1H,  $^3J$  = 6.9 Hz, 6-H), 5.60 (d, 1H,  $^3J$  = 6.0 Hz, =CH), 5.8 (d, 1H,  $^3J$  = 7.9 Hz, =CH), 5.85 (d, 1H,  $^2J$  = 7.9 Hz, =CH), 5.90 (d,  $^2J$  = 7.9 Hz, 1H, =CH), 6.15 (dd, 1H,  $^3J$  = 6.6 Hz,  $^3J$  = 6.5 Hz, 5-H). -  $^{13}\text{C}$  NMR (100.6 MHz, acetone- $d_6$ , APT):  $\delta$  = 55.6 (-, OCH<sub>3</sub>), 56.0 (-, OCH<sub>3</sub>), 58.7 (-, OCH<sub>3</sub>), 73.6 (-, C-4), 80.3 (-, C-5), 87.2 (-, C-3), 94.8 (+, C-3a), 95.7 (-, C-6), 97.9 (+, C-3b), 113.5 (+, C-7a), 127.5 (-, C-10, or C-11), 129.6 (-, C-10, or C-11), 142.8 (+, C-7), 145.0 (+, C-1 or C-2), 148.5 (+, C-1 or C-2), 181.3 (+, C-8a), 197.9 (+, C-8), 232.8 (+, CO). - MS (70eV, 190°C):  $m/z$  (%) = 438 (28) [ $\text{M}^+$ ], 382 (77) [ $\text{M} - 2\text{CO}$ ], 354 (59) [ $\text{M} - 3\text{CO}$ ], 308 (100) [ $\text{M} - 3\text{CO}, \text{OCH}_3\text{CH}_3$ ], 277 (14), 255 (44), 233 (42), 155 (38), 111 (19), 91 (65), 71 (34), 57 (47). - HRMS ( $\text{C}_{20}\text{H}_{18}\text{CrO}_8$ ): calcd. 438.040678, found 438.039703.

## 20.4 Addition of 1-Cyclopentenyllithium to Complex 42

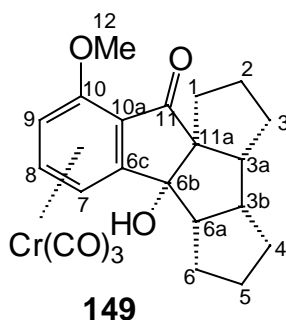

**GP V**; 700 mg (5.4 mmol) of 1-bromocyclopentene in 10 ml diethyl ether and 55 mg (6.5 mmol) of lithium sand in 10 mL diethyl ether heating at reflux for 1 h,<sup>110</sup> and then cooled to  $-78^{\circ}\text{C}$ . To the cooled solution of 1-cyclopentenyllithium a solution of 200 mg (0.7 mmol) of **42** in THF/diethyl ether (1:1) at  $-78^{\circ}\text{C}$  was added dropwise. Stirring for 16 h at  $-78^{\circ}\text{C}$ , hydrolysis with 10 mL 1M hydrochloric acid, extracted three times with 20 mL of TBME, column chromatography (200  $\times$  20 mm, PE, then TBME/PE, 6:1), 259 mg (0.597mmol, 89 %) of Tricarbonyl $\{\eta^6\text{-}1,2,3,3\text{a},3\text{b},4,5,6,6\text{a},6\text{b}\text{-decahydro-}6\text{b-endo-hydroxy-endo-cyclopenta-}[5,6]\text{-}10\text{-methoxy-endo-pent-aleno-}[4,5\text{-}\alpha\text{-inden-}11\text{-on}\}\text{chromium (0)}$  (**149**) as an orange solid (m.p.  $194^{\circ}\text{C}$ ).

**149**: IR: (ATR):  $\tilde{\nu} = 3469$  (br, OH)  $\text{cm}^{-1}$ , 2950 (m), 1971 (s, CO), 1896 (s, CO), 1706 (s, C=O), 1524 (w), 1459 (m), 1429 (w), 1406 (w), 1277 (m), 1226 (w), 1184 (w), 1038 (m), 888 (w), 829 (w), 756 (w), 684 (w), 625 (m), 530 (w), 479 (w). -  $^1\text{H}$  NMR (400.1 MHz, acetone- $d_6$ ):  $\delta = 1.58$  (m, 2H, aliph.-H), 1.65 (m, 3H, aliph.-H), 1.78 (m, 2H, aliph.-H), 1.88 (m, 3H, aliph.-H), 2.57 (m, 2H, aliph.-H), 2.64 (m, 1H, 3a or 3b-H), 2.78 (m, 1H, 3a or 3b), 3.80 (3H, OCH<sub>3</sub>), 4.43 (s, 1H, OH). 5.48 (dd, 2H,  $^3J = 6.0$  Hz,  $^3J = 5.9$  Hz, 7-H + 9-H), 6.13 (dd, 1H,  $^3J = 6.4$  Hz,  $^3J = 6.4$  Hz, 8-H). -  $^{13}\text{C}$  NMR (100.6 MHz, acetone- $d_6$ , APT):  $\delta = 24.7$  (+, aliph.C), 26.3 (+, aliph. C), 27.4 (+, aliph. C), 28.1 (+, aliph. C), 29.0 (+, aliph. C), 30.2 (+, aliph. C), 34.7 (+, C-11a), 48.3 (-, C-3a), 51.3 (-, C-3b), 55.5 (-, C-12), 60.9 (-, C-6a), 74.3 (-, C-7), 75.2 (-, C-6b), 79.9 (-, C-8), 83.4 (+, C-10a), 96.2 (-, C-9), 132.2 (+, C-6c), 141.0 (+, C-10), 205.4 (+, C-11), 231.5 (+, CO). - MS (70eV,  $130^{\circ}\text{C}$ ):  $m/z$  (%) = 434 (14) [ $\text{M}^+$ ], 378 (12) (M - 2CO), 350 (100) (M - 3CO), 335 (60) [M - 3CO, CH<sub>3</sub>], 317 (5), 298 (12), 257 (6), 230 (7), 211 (5), 190 (10), 166 (5), 145 (7), 127 (5), 107 (4), 91 (6), 75 (18), 52 (11) [Cr]. - HRMS (C<sub>22</sub>H<sub>22</sub>CrO<sub>6</sub>): calcd. 434.082153; found. 434.082148.

## Crystal Structure Analysis of 149:

$C_{22}H_{22}CrO_6$ , molecular weight, 434.41: crystal system monoclinic. Space group  $p\ 2_1/n$  (no. 14),  $a = 10.470(2)$ ,  $b = 13.762(2)$ ,  $c = 13.877(2)$  Å,  $\alpha = 90$ ,  $\beta = 103.26(2)$ ,  $\gamma = 90^\circ$ ,  $V = 1946.2(6)$  Å<sup>3</sup>,  $Z = 4$ ,  $d_{calcd} = 1.483$  gcm<sup>-3</sup>,  $d_{obs} = 0.000$ ,  $F(000) = 904e$ ,  $\mu = 6.3$  cm<sup>-1</sup>, crystal: red plate  $\parallel (100)$ , size  $0.03 \times 0.33 \times 0.26$  mm, Stoe IPDS (Imaging Plate) diffractometer,  $T = 300$  K,  $MoK_\alpha = 0.71073$  Å,  $2\theta_{min} = 4.1^\circ$ ,  $2\theta_{max} = 48.3^\circ$ , scan type 150 exposure,  $\Delta\Phi = 1.5^\circ$ , 14094 measured reflections ( $\pm 12$ ,  $\pm 15$ ,  $\pm 15$ ), 3073 independent [ $R(I)_{int} = 0.100$ ] and 1500 observed reflection [ $I_t > 2.0 \sigma(I)$ ], completeness of data: 99.7%, no absorption correction, no extinction correction, structure solution with direct methods with SHELXS-86, refinement with SHELXL-93, hydrogen atoms in geometrically calculated positions,  $N_{ref} = 3073$ ,  $N_{par} = 266$ ,  $R = 0.0402$ ,  $R_w = 0.0647$  [ $w = 1/\sigma^2(F_o^2)$ ],  $S = 0.86$ , minimal and maximal residual electron density  $-0.40/0.23$  eÅ<sup>-3</sup>.

## 20.5 Addition 2,3-dihydrofuranyllithium to Complex 42

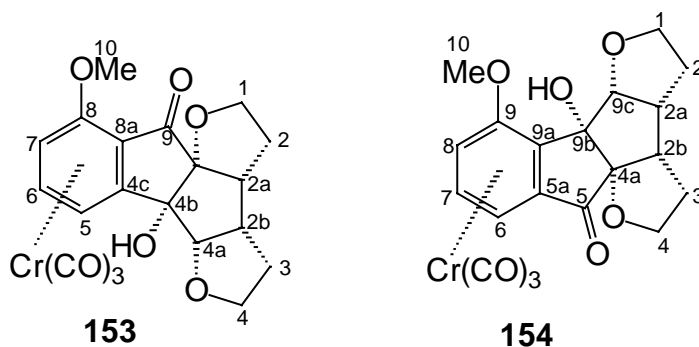

**GP V**; 375 mg (5.4 mmol) of 2,3-dihydrofuran in 10 mL of THF was added to 3.3 mL (5.4 mmol) of 1.6 M butyllithium in hexane at  $-78^\circ\text{C}$  and warmed up to  $0^\circ\text{C}$  over 45 min.<sup>128</sup> To the lithiated solution at  $-78^\circ\text{C}$ , a solution of 200 mg (0.7 mmol) of **42** in THF/diethyl ether (1:1) was added; stirring for 16 h at –

78°C, hydrolysis with 10 mL of 1M hydrochloric acid, extraction three times with 25 mL of TBME, column chromatography (200 × 20 mm, PE, then EE/TBME, 1:2), 179 mg (0.4 mmol, 72%) of Tricarbonyl{ $\eta^6$ -1,2,2a,2b,3,4,4a,4b-octahydro-5*H*-benzo[5,6]furo-[3'2':3,3a]-8-methoxypentaleno[1,2-b]furan-9-on}chromium (**153**) and Tricarbonyl{ $\eta^6$ -1,2,2a, 2b, 3,4,9c,9b-octahydro-5*H*-benzo[5,6]furo-[3'2':3,3a]-9-methoxypentaleno-[1,2-b]furan-5-on}-chromium (**154**) were obtained as a red oil in a mixture of approximately 1:1 ratio (NMR).

**153** and **154**: IR: (ATR):  $\tilde{\nu}$  = 3432 (br, OH)  $\text{cm}^{-1}$ , 2959 (m), 2886 (w), 1964 (s, CO), 1875 (s, CO), 1715 (s, C=O), 1522(w), 1456 (m), 1431 (w), 1361(w), 1262 (s), 1180 (w), 1014(s), 923 (m), 814 (w), 752(w), 658 (m). **153** -  $^1\text{H}$  NMR (400.1 MHz, acetone- $d_6$ ):  $\delta$  = 2.10 (m, 2H, aliph.-H), 2.76 (m, 2H, aliph.-H), 2.92 (m, 2H, aliph.-H), 3.85 (3H, OCH<sub>3</sub>), 4.05(s, 1H, OH), 4.32(d, 1H,  $^3J_{endo-4a, endo-2b}$  = 6.4 Hz, 4a-H), 5.31 (d, 1H,  $^3J$  = 6.1 Hz, 5-H), 5.45 (d, 1H,  $^3J$  = 6.6 Hz, 7-H), 5.89( t, 1H,  $^3J$  = 6.4 Hz,  $^3J$  = 6.5 Hz, 6-H). -  $^{13}\text{C}$  NMR (100.6 MHz, acetone- $d_6$ , APT):  $\delta$  = 29.8 (+, C-2 or C-3), 29.8 (+, C-3 or C-2), 42.7 (-, C-2a or C-2b), 49.7 (-, C-2b or C-2a), 55.7 (-, C-8), 68.9 (+, C-1 or C-4), 72.7 (+, C-4 or C-1), 81.2 (+, C-4b), 88.4 (-, C-5), 91.7 (-, C-6), 94.4 (-, C-7), 95.8 (-, C-4a), 96.2 (+, C-9a), 96.7 (+, C-4c), 127.9 (+, C-8a), 141.3 (+, C-8), 203.8 (+, C-9), 231.5 (+, CO). - MS (70eV, 150°C):  $m/z$  (%) = 438 (3) [ $\text{M}^+$ ], 382 (3) [ $\text{M} - \text{CO}$ ], 354 (21) [ $\text{M} - 3\text{CO}$ ], 302 (21), 274 (3), 257 (21), 220 (38), 203 (7), 176 (14), 158 (4), 141 (8), 108 (31), 87 (23), 71 (100) [ $\text{C}_4\text{H}_7\text{O}$ ], 52 (32) [Cr].

**154** only data different from **177**: IR: (ATR):  $\tilde{\nu}$  1769 (C=O)  $\text{cm}^{-1}$ . -  $^1\text{H}$  NMR (400.1 MHz, acetone- $d_6$ ):  $\delta$  = 3.82 (3H, OCH<sub>3</sub>), 4.87(s, 1H, OH), 4.57(d, 1H,  $^3J$  = 5.5 Hz, 4a-H), 5.38 (d, 1H,  $^3J$  = 6.1 Hz, 5-H), 5.69 (d, 1H,  $^3J_{endo-4a, endo-2b}$  = 6.5 Hz, 7-H), 6.19 (dd, 1H,  $^3J$  = 6.1 Hz,  $^3J$  = 6.3 Hz, 6-H). -  $^{13}\text{C}$  NMR (100.6 MHz, acetone- $d_6$ , APT):  $\delta$  = 56.0 (-, C-9), 73.7 (-, C-6 or C-7 or C-8), 76.4 (-, C-6 or C-7 or C-8), 79.2 (-, C-6 or C-7 or C-8), 79.6 (+, C-5a), 81.2 (-, C-9c),

85.7 (+, C-4a), 98.9 (+, C-9a), 110.4 (+, C-9a), 140.1 (+, C-9), 198.7 (+, C-5), 230.9 (+, CO). -HRMS (C<sub>20</sub>H<sub>18</sub>CrO<sub>8</sub>): calcd 438.040678; found.438.040833.

## 20.6 Addition of 3,4-dihydro-2H-pyranyllithium to Complex 42

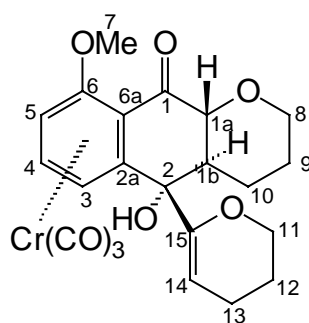

**159**

**GP V**; 337 mg (4.0 mmol) of 3,4-dihydro-2H-pyrane in 10 mL of THF was added to 2.5 mL (4.0 mmol) of 1.6 M butyllithium in hexane at  $-78\text{ }^{\circ}\text{C}$  and warmed up to  $0\text{ }^{\circ}\text{C}$  over 45 min.<sup>128</sup> The solution was cooled to  $-78\text{ }^{\circ}\text{C}$ , added to a solution of 150 mg (0.5 mmol) of **42** in THF/diethyl ether (1:1) at  $-78\text{ }^{\circ}\text{C}$ ; stirring for 16 h at  $-78\text{ }^{\circ}\text{C}$ , hydrolysis with 10 mL 1M hydrochloric acid, extraction three times with 20 mL of TBME, column chromatography (200  $\times$  20 mm, PE, then TBME/PE, 3:1), 140 mg (0.3 mmol, 60%) of tricarbonyl{ $\eta^6$ -5-(5,6-Dihydro-4H-pyran-3-yl)-5-hydroxy-9-methoxy-3,4, 4a,10a-tetrahydro-2H,5H-benzo[g]chromen-10-one}chromium (0) (**159**) was obtained as an orange-red solid (m.p.  $174\text{ }^{\circ}\text{C}$ ).

**159**: IR: (ATR):  $\tilde{\nu} = 3412$  (br, OH)  $\text{cm}^{-1}$ , 2941 (m), 1958 (s, CO), 1872 (s, CO), 1710 (s, C=O), 1628 (w), 1598 (w), 1525 (w), 1461 (m), 1430 (m), 1365 (m), 1267 (s), 1176 (m), 1034 (s), 951 (m), 916 (m), 848 (w), 761 (s), 664 (s). -  $^1\text{H}$  NMR (400.1 MHz, acetone- $d_6$ ):  $\delta = 1.57 - 1.88$  (m, 8H, 9-H, 10-H + 12-H + 13-H), 3.51 (m, 1H, 1b-H), 3.80 (3H, OCH<sub>3</sub>), 3.93 (m, 2H, 8-H or 11-H), 4.05 (m, 2H, 8-H or 11-H), 4.84 (s, 1H, 1a-H), 4.84 (d, 1H,  $^3J = 5.4$  Hz, 14-H), 5.07 (s, 1H, OH), 5.48 (d, 1H,  $^3J = 5.1$  Hz, 3-H), 5.56 (d, 1H,  $^3J = 6.5$  Hz, 5-

H), 6.09 (m, 1H, 4-H). -  $^{13}\text{C}$  NMR (100.6 MHz, acetone- $d_6$ , APT):  $\delta$  = 19.8 (+, C-9 or C-10 or C-12 or C-13), 21.8 (+, C-9 or C-10 or C-12 or C-13), 22.6 (+, C-9 or C-10 or C-12 or C-13), 25.3 (+, C-9 or C-10 or C-12 or C-13), 48.2 (-, C-1b), 55.6 (-, C-7), 66.0 (+, C-8 or C-11), 66.8 (+, C-11 or C-8), 71.7 (+, C-2), 73.0 (+, C-6a), 74.0 (-, C-1a), 75.6 (-, C-14), 83.3 (-, C-3), 95.3 (-, C-4), 101.9 (-, C-5), 142.4 (+, C-2a), 152.2 (+, C-6), 195.2 (+, C-1), 233.1 (+, CO). - MS (70eV, 160°C):  $m/z$  (%) = 466 (5) [ $\text{M}^+$ ], 382 (23) [ $\text{M} - 3\text{CO}$ ], 330 (13), 247 (9), 220 (3), 101 (7), 52 (22)[Cr]. - HRMS ( $\text{C}_{22}\text{H}_{22}\text{CrO}_8$ ) : calcd. 466.071978, found. 466.071930.

### Crystal Structure Analysis of 159

$\text{C}_{22}\text{H}_{22}\text{CrO}_8$ , molecular weight, 466.4: crystal system monoclinic. Space group  $p2_1/n$  (no. 14),  $a = 14.456(5)$ ,  $b = 14.799(5)$ ,  $c = 21.437(10)$  Å,  $\alpha = 90$ ,  $\beta = 109.12(5)$ ,  $\gamma = 90^\circ$ ,  $V = 4333(3)$  Å $^3$ ,  $Z = 8$ ,  $d_{\text{calcd.}} = 1.430$  gcm $^{-3}$ ,  $F(000) = 1936e$ ,  $\mu = 5.7$  cm $^{-1}$ , crystal: red plate  $\parallel$  (001), size  $0.24 \times 0.16 \times 0.06$  mm, Stoe IPDS (Imaging Plate) diffractometer,  $T = 300$  K,  $\text{MoK}\alpha = 0.71073$  Å,  $2\theta_{\text{min}} = 3.4^\circ$ ,  $2\theta_{\text{max}} = 42.2^\circ$ , scan type 200 exposure,  $\Delta\Phi = 1.0^\circ$ , 18264 measured reflections ( $\pm 14$ ,  $\pm 14$ ,  $\pm 21$ ), 4547 independent [ $R(I)_{\text{int}} = 0.31$ ] and 761 observed reflection [ $I_t > 2.0 \sigma(I)$ ], completeness of data: 100 %, no absorption correction, no extinction correction, structure solution with direct methods with SHELXS-86, refinement with SHELXL-93, hydrogen atoms in geometrically calculated positions,  $N_{\text{ref}} = 4547$ ,  $N_{\text{par}} = 230$ ,  $R = 0.1766$ ,  $R_w = 0.3027$  [ $w = 1/\sigma^2(F_o^2)$ ],  $S = 1.07$ , minimal and maximal residual electron density  $-0.95/1.62$  eÅ $^{-3}$ .





C-17), 140.9 (+, C-1), 150.9 (C-9 or C-14), 152.9(+, C-9 or C-14), 176.5 (+, C-13), 179.1(+, C-8), 231.9 (+, CO). - MS (70eV, 160°C):  $m/z$  (%) = 432 (3)[M<sup>+</sup>], 376 (30) [M – 2CO], 348 (100) [M – 3CO], 322 (29), 296 (30), 267 (42), 239 (3), 220 (21), 202 (7), 174 (5), 155 (5), 127 (7), 95 (19), 73 (37), 52 (25). - HRMS (C<sub>20</sub>H<sub>12</sub>O<sub>8</sub>Cr): calcd. 431.993727, found. 431.979858.

## 21 Synthesis of Trifluoromethylbenzocyclobutenone and Trifluoromethylbenzocyclobutendione Complexes

### 21.1 1,1-Diethoxy-6-(trifluoromethyl)-benzocyclobutene (172)

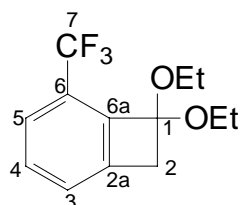

### 172

20.00 g (0.17 mol) of 1,1-diethoxyethene and then 20.00 g (0.09 mol) of 1-bromo-3-trifluoromethylbenzene were added dropwise to a suspension of 9 g (0.23 mol) of sodium amide in 50 mL of THF. The mixture was stirred at reflux for 14 h. After consumption of the bromide (GC control) the black brown suspension was cooled to room temperature and poured into a separator funnel filled with 200 mL of ice. After addition of 200 mL of water the mixture was extracted four times with 100 ml of dichloromethane each. The collected organic layers were washed with a saturated aqueous solution of sodium chloride and dried over sodium sulfate, and the solvent was removed. After purification by column chromatography (SiO<sub>2</sub>, deactivated with triethylamine, 200 × 30 mm, petroleum ether/TMBE 7:1), 10.00 g (0.04 mol, 46 %) of **172** was obtained as a yellow oil.

**172:** IR (ATR):  $\tilde{\nu}$  = 2978 (w)  $\text{cm}^{-1}$ , 2935 (w), 2884 (w), 1614 (w), 1483 (w), 1433 (w), 1366 (w), 1319 (s, C-F), 1241 (s), 1170 (s), 1127 (s), 1087 (m), 1060 (s), 992 (w), 929 (w), 786 (w). -  $^1\text{H}$  NMR (400.1 MHz, acetone- $d_6$ ):  $\delta$  = 1.24 (t, 6H,  $^3J$  = 7.0 Hz, 2  $\times$  CH<sub>3</sub>), 3.42 (s, 2H, 2-H), 3.72 (dd, 4H,  $^3J$  = 7.2 Hz, 2  $\times$  CH<sub>2</sub>), 7.38 - 7.44 (m, 3H, 4-H + 3-H + 5-H). -  $^{13}\text{C}$  NMR (100.6 MHz, acetone- $d_6$ , APT):  $\delta$  = 15.2 (-, 2  $\times$  CH<sub>3</sub>), 44.0 (+, C-2), 59.5(+, 2  $\times$  CH<sub>2</sub>), 104.9 (+, C-1), 123.7 (q, +,  $^1J_{\text{C-F}}$  = 271 Hz, C-7), 124.8 (-, C-3), 126.7 (-, C-4), 130.1 (q, -,  $^3J_{\text{C-F}}$  = 4.0 Hz, C-5), 137.0 (+,  $^3J_{\text{C-F}}$  = 37.0 Hz, C-6), 155.1 (-, C-6a). - MS (70eV, RT $^\circ$  C):  $m/z$  (%) = 260 (2)[M<sup>+</sup>], 245 (4), 215 (31), 187 (100) [M - C<sub>4</sub>H<sub>9</sub>O], 167 (59), 136 (51), 119 (12), 104 (28), 89 (8), 77 (8), 63 (7). - HRMS (C<sub>13</sub>H<sub>15</sub>O<sub>2</sub>F<sub>3</sub>): calcd. 260.102415, found 260.102081; calcd. C 59.99 H 5.82, found. C 60.58 H 6.41.

## 21.2 1,1-Diethoxy-6-(trifluoromethyl)-benzocyclobutene Complex **176**

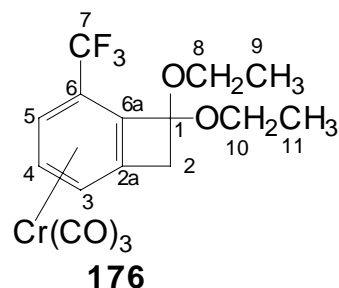

8.00 g (30.8 mmol) of 1,1-diethoxy-6-(trifluoromethyl)benzocyclobutene (**172**) and 8.12 g (36.9 mmol) of hexacarbonylchromium in 200 mL of dibutyl ether and 20 mL of THF were heated at reflux for 20 h. After cooling to room temperature the solution was filtered through a 5 mm thick layer of silica gel eluting with THF. After solvent removal the residue was purified by column chromatography (SiO<sub>2</sub>, 400  $\times$  30 mm, TMBE/ PE, 2:1); 7.6 g (19 mmol, 62 %) of *rac.*-**176** as yellow solid (m.p.46  $^\circ\text{C}$ ).

**176:** IR (ATR):  $\tilde{\nu}$  = 2978 (w)  $\text{cm}^{-1}$ , 2935 (w), 2884 (w), 1982 (s, CO), 1909 (s, CO), 1523 (w), 1482 (w), 1445 (w), 1421 (w), 1388 (w), 1318 (s, C-O), 1240 (s, C-F), 1173 (s), 1128 (s), 1085 (m), 1060 (s), 990 (w), 928 (w), 833 (w), 788 (w), 741 (w), 659 (w). -  $^1\text{H}$  NMR (400.1 MHz, acetone- $d_6$ ):  $\delta$  = 1.24 (t, 6H,  $^3J$  = 7.03 Hz, 9(11)-H), 3.31 (dd, 2H, *endo*-2 or *exo*-2,  $^2J_{\text{endo-2,exo-2}}$  = -13.8 Hz, *exo*-2 or *endo*-2,  $^2J_{\text{exo-2,endo-2}}$  = -13.8 Hz, 2-H), 3.67 (m, 4H,  $^3J$  = 7.3 Hz, 8(10)-H), 5.19 (s, 5.29 (d, 1H,  $^3J$  = 6.6 Hz, 3-H), 5.57 (d, 1H,  $^3J$  = 6.0 Hz, 5-H), 6.05 (dd,  $^3J$  = 6.4 Hz,  $^3J$  = 6.3 Hz, 4-H). -  $^{13}\text{C}$  NMR (100.6 MHz, acetone- $d_6$ , APT):  $\delta$  = 14.1 (-, C-9 or C-11), 14.3 (-, C-9 or C-11), 43.6 (+, C-2), 59.0 (+, C-8 or C-10), 59.6 (C-8 or C-10), 86.1(q, -,  $^3J_{\text{C-F}}$  = 3.3 Hz, C-5), 89.1(-, C-4), 91.6 (-, C-3), 94.1 (d, +,  $^2J$  = 37.6 Hz, C-6), 104.8 (+, C-1), 110.8 (+, C-2a), 127.2 (q, +,  $^1J_{\text{C-F}}$  = 273 Hz, C-7), 143.2 (+, C-6a), 230.9 (+, CO). - MS (70eV, RT $^\circ$  C):  $m/z$ (%) = 396 (44) [ $\text{M}^+$ ], 240 (33) [ $\text{M} - 2\text{CO}$ ], 312 (72) [ $\text{M} - \text{CO}$ ], 267 (24), 235 (49), 215 (18), 196 (100) [ $\text{M} - 3\text{CO} - \text{C}_2\text{H}_4\text{O}$ ], 167 (53), 145 (30), 120 (27), 102 (14), 75 (6), 52 (12) [Cr]. - HRMS ( $\text{C}_{16}\text{H}_{15}\text{CrF}_3\text{O}_5$ ): calcd. 396.027668 found.396.027466; calcd. 48.49, H 3.82; found. C 48.43, H 3.85.

### 21.3 6-(Trifluoromethyl)benzocyclobutenone complex **168**

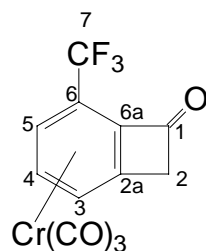

**168**

At 0 $^\circ\text{C}$  150 mL of half-concentrated hydrochloric acid was added to 4 g (10.1 mol) of *rac*-**176** in the dark. The mixture was stirred for 2h at 25  $^\circ\text{C}$ , becoming orange. The mixture was extracted twice with 100 mL of TMBE each, and the

collected organic layers were washed with 100 mL of water. After drying the collected organic layers over magnesium sulfate, the solvent was removed at reduced pressure. 3.09 g (9.6 mmol, 95%) of *rac*-**168** was obtained as an orange-red solid (m. p. 65 °C).

**168**: IR (ATR):  $\tilde{\nu}$  = 3119 (w)  $\text{cm}^{-1}$ , 3081 (w), 2961 (w), 1987 (s, CO), 1897 (s, CO), 1767 (s, C=O), 1524 (m), 1496 (m), 1447 (m), 1412 (w), 1398 (w), 1369 (m), 1314 (s, C-F), 1220 (s), 1182 (m), 1169 (m), 1130 (s), 1103 (s, C-F), 976 (m), 958 (m), 919 (m), 851 (m), 804 (w), 757 (w), 729 (w), 698 (w). -  $^1\text{H}$  NMR (400.1 MHz, acetone- $d_6$ ):  $\delta$  = 3.94 (d, 1H, *exo*-2 or *endo*-2,  $^2J_{\text{exo-2, endo-2}} = -16.7$  Hz, 2-H), 4.32 (d, 1H, *endo*-2 or *exo*-2,  $^2J_{\text{endo-2, exo-2}} = -16.8$  Hz, 2-H), 5.89 (d, 1H,  $^3J = 6.5$  Hz, 5-H), 6.15 (dd, 1H,  $^3J = 6.4$  Hz,  $^3J = 6.4$  Hz, 4-H), 6.36 (d, 1H,  $^3J = 6.5$  Hz, 3-H). -  $^{13}\text{C}$  NMR (100.6 MHz, acetone- $d_6$ , APT):  $\delta$  = 53.2 (+, C-2), 87.0 (q, -,  $^3J_{\text{C-F}} = 3.3$  Hz, C-5), 89.1 (-, C-4), 93.4(d, +,  $^3J = 39$  Hz, C-6), 93.8(-, C-3), 117.4(+, C-2a), 123.2 (q, +,  $^1J_{\text{C-F}} = 273$  Hz, C-7), 140.7 (+, C-6a), 180.6 (+, C-1), 229.1 (+, CO). - MS (70eV, 70 °C):  $m/z$  (%) = 322 (65) [ $\text{M}^+$ ], 266 (20) [ $\text{M} - 2\text{CO}$ ], 238 (57) [ $\text{M} - 3\text{CO}$ ], 218 (100)[ $\text{M} - 3\text{CO} - \text{HF}$ ], 190 (3), 167 (3), 148 (7), 120 (88), 101 (9), 75 (8), 52 (13) [Cr]. - CHN ( $\text{C}_{12}\text{H}_5\text{O}_4\text{F}_3\text{Cr}$ ) 322.159 : Calcd: C 44.74 H 1.56; Found: C 42.69 H 2.22

### Crystal Structure Analysis of 168

$\text{C}_{12}\text{H}_5\text{CrF}_3\text{O}_6$ , molecular weight, 322.16: crystal system monoclinic. Space group p 21/c (no. 14),  $a = 11.787(4)$ ,  $b = 7.915(2)$ ,  $c = 13.183(6)$  Å,  $\alpha = 90$ ,  $\beta = 93.22(5)$ ,  $\gamma = 90^\circ$ ,  $V = 1228.0(8)$  Å<sup>3</sup>,  $Z = 4$ ,  $d_{\text{calcd.}} = 1.743$   $\text{gcm}^{-3}$ ,  $F(000) = 640e$ ,  $\mu = 9.8$   $\text{cm}^{-1}$ , crystal: orange-red plate | | (001), size 0.15 × 0.26 × 0.04 mm, Stoe IPDS (Imaging Plate) diffractometer,  $T = 300$  K,  $\text{MoK}_\alpha = 0.71073$  Å,  $2\theta_{\text{min}} = 6.2^\circ$ ,  $2\theta_{\text{max}} = 48.5^\circ$ , scan type 100 exposure,  $\Delta\Phi = 1.8^\circ$ , 2793 measured reflexions (-12, + 13, ±8, ±15), 1001 independent [ $R(I)_{\text{int}} = 0.144$ ] and 272 observed reflection [ $I_t > 2.0 \sigma(I)$ ], completeness of data: 51.5 %, no absorption

correction, no extinction correction, structure solution with direct methods with SHELXS-86, refinement with SHELXL-93, hydrogen atoms in geometrically calculated positions,  $N_{\text{ref}} = 1001$ ,  $N_{\text{par}} = 121$ ,  $R = 0.0368$ ,  $R_w = 0.0764$  [ $w = 1/\sigma^2 (F_o^2)$ ],  $S = 0.52$ , minimal and maximal residual electron density – 0.20/0.20  $\text{e}\text{\AA}^{-3}$ .

#### 21.4 6-(Trifluoromethyl)benzocyclobutenone (**173**)

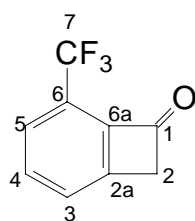

**173**

At 0°C 100 mL of 1 M hydrochloric acid was added to 12.00 g (46.0 mmol) of **172**. The mixture was stirred for 24 h at 25°C. The mixture was extracted twice with 100 mL of TMBE each, and the collected organic layers were washed with 100 mL of water. After drying the collected organic layers over magnesium sulfate, the solvent was removed at reduced pressure. After solvent removal the residue was purified by column chromatography ( $\text{SiO}_2$ , 400 × 30 mm, TMBE/ petroleum ether 1:5), yielding 8.07g (0.4 mol, 94%) of *rac*-**173** as yellow solid (m. p. 35°C).

**173** IR: (ATR)  $\tilde{\nu} = 3530$  (w)  $\text{cm}^{-1}$ , 3049 (w), 2359 (w), 1771 (s, C=O), 1653 (w), 1613 (w), 1585 (m), 1489 (m), 1412 (m), 1325 (s, C-F), 1248 (s), 1163 (s), 1100 (s), 996 (m), 968 (s), 916 (w), 803 (s), 754 (w), 739 (m), 728 (m), 686 (w). -  $^1\text{H}$  NMR(400.1 MHz, acetone- $d_6$ ):  $\delta = 4.15$  (s, 2H, 2-H), 7.80 (d,

1H,  $^3J = 7.8$  Hz, 5-H), 7.83 (dd, 1H,  $^3J = 7.9$  Hz,  $^3J = 7.2$  Hz, 4-H), 7.85 (d, 1H,  $^3J = 7.3$  Hz, 3-H). -  $^{13}\text{C}$  NMR (100.6 MHz, acetone- $d_6$ ):  $\delta = 52.7$  (+, C-2), 121.0 (+,  $^1J = 273.1$  Hz, C-7), 122.2 (d, +,  $^2J = 36$  Hz, C-6), 123.7 (+, C-2a), 125.13 (q, -,  $^3J_{\text{C-F}} = 4.5$  Hz,  $^3J_{\text{C-F}} = 4.3$  Hz, C-5), 127.6 (-, C-4), 135.4 (-, C-3), 152.17 (+, C-6a), 183.32 (+, C-1). - MS(70 eV, 168°C):  $m/z$  (%) = 186 (100) [ $\text{M}^+$ ], 167 (8), 158 (79), 138 (42), 119 (3), 108 (7), 99 (2), 89 (3), 81 (1), 63 (2). CHN ( $\text{C}_9\text{H}_5\text{OF}_3$ ) 186.0899: Calcd. C 58.09, H 2.70; found C 56.44, H 2.88.

### 21.5 2,2-Dibromo-6-(Trifluoromethyl)benzocyclobutenone (174)

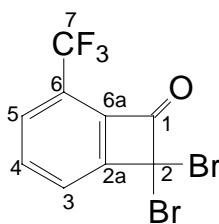

**174**

8.00 gm (43.00 mmol) of 6-trifluoromethylbenzocyclobutenone (**173**), 19.14 g (108.0 mmol) of *N*-bromosuccinimide and 1.3 g (5.4 mmol) dibenzoylperoxide in 200 ml carbon tetrachloride were heated at reflux for 5 days. The solution was cooled at 20 °C. 100 mL of Petroleum ether was added to precipitate the succinimide. The solid was filtered off on a Büchner funnel and washed with petroleum ether. The filtrate was concentrated and filtered through a short silica column, eluting with methylene chloride. After solvent removal the residue was purified by column chromatography (  $\text{SiO}_2$ , 400 × 30 mm, TMBE / petroleum ether 1:4), yielding 6.80 g (0.0198 mol, 46 %) of rac. **174** as yellow solid (m.p.83°C).

**174** IR: (ATR):  $\tilde{\nu} = 3090$  (w)  $\text{cm}^{-1}$ , 1798 (s, C=O), 1584 (w), 1494 (w), 1413 (w), 1324 (s, C-F), 1243 (w), 1181 (s), 1138 (s, C-F), 1106 (s), 1042 (w), 988

(m), 919 (m), 849 (w), 793 (m), 746 (w), 715 (w), 685 (m). -  $^1\text{H}$  NMR (400.1 MHz,  $\text{CDCl}_3$ ):  $\delta$  = 7.87 (d, 1H,  $^3J$  = 7.7 Hz, 5-H), 7.90 (dd, 1H,  $^3J$  = 8.0 Hz,  $^3J$  = 7.6 Hz, 4-H), 7.65 (d, 1H,  $^3J$  = 7.6 Hz, 3-H). -  $^{13}\text{C}$  NMR (100.6 MHz, acetone- $d_6$ ):  $\delta$  = 57.8 (+, C-2), 122.3 (q, +,  $^1J_{\text{C-F}}$  = 273 Hz, C-7), 125.7 (-, C-3), 126.2 (d, +,  $^2J$  = 37.6 Hz, C-6), 130.3 (q, -,  $^3J_{\text{C-F}}$  = 4.02 Hz, 5-C), 136.6 (+, C-2a), 137.9(-, C-4), 159.2 (+, C-6a), 174.3 (+, C-1). - MS (70eV, 168°C):  $m/z$  (%) = 344(100)[ $\text{M}^+$ ], 316 (8), 298 (6), 265 (34), 235 (81), 216 (2), 191 (9), 156 (62), 137 (6), 106 (13), 78 (20). - HRMS ( $\text{C}_9\text{H}_3\text{O}_1\text{F}_3\text{Br}_2$ ): calcd. 341.850372; found. 341.850372. (343.9253): Cal. C 31.43 H, 2.79; Found: C 31.80, H 1.04.

### 21.6 3-(Trifluoromethyl)benzocyclobutenedione **175**

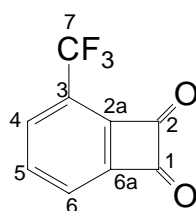

**175**

At 0°C 100 mL of 50% sulfuric acid was added to 6.00 g (17.0 mmol) of **174**. The mixture was heated at reflux for 24 h. The color changed into dark brown. The mixture was cooled and was extracted twice with 100 mL of dichloromethane each, and the collected organic layers were washed with 100 ml of water. After drying the collected organic layers over  $\text{MgSO}_4$ , the solvent was removed at reduced pressure. After solvent removal the residue was purified by column chromatography ( $\text{SiO}_2$ , 400 × 30 mm, TMBE/ PE 1:2), yielding 1.88 g (9.4 mmol, 56%) of *rac.*-**175** as yellow solid (m. p 84°C).

**175** IR: (ATR):  $\tilde{\nu}$  = 3089 (w)  $\text{cm}^{-1}$ , 1773 (s, C=O), 1686 (w), 1602 (m), 1574 (w), 1487 (w), 1404 (w), 1359 (m, C-F), 1317 (s), 1237 (m), 1169 (s), 1130 (s,



C-F), 1083 (s), 1012 (m), 955 (m), 855 (m), 843 (m), 831 (m), 806 (s), 719 (m), 701 (w). -  $^1\text{H}$  NMR (400.1 MHz, acetone- $d_6$ ):  $\delta$  = 8.18 (dd, 1H,  $^3J$  = 7.5 Hz,  $^3J$  = 8.2 Hz, 5-H), 8.25 (d, 1H,  $^3J$  = 8.0 Hz, 6-H), 8.45 (d, 1H,  $^3J$  = 7.7 Hz, 4-H). -  $^{13}\text{C}$  NMR (100.6 MHz, acetone- $d_6$ , APT):  $\delta$  = 120.7 (q, +,  $^1J_{\text{C-F}}$  = 272.2 Hz, C-7), 124.5 (q, +,  $^2J$  = 37.4 Hz, C-3), 125.8 (-, C-5), 132.0 (q, -,  $^3J_{\text{C-F}}$  = 4.2 Hz, C-4), 136.2 (-, C-6), 186.8 (+, C-2a), 172.6 (+, C-6a), 190.0 (+, C-1), 192.5 (+, C-2). - MS (70eV, RT °C):  $m/z$  (%) = 200 (20)[ $\text{M}^+$ ], 172 (100)[ $\text{M} - \text{CO}$ ], 144 (91), 125 (23), 94 (10), 85 (2), 75 (16). - HRMS ( $\text{C}_9\text{H}_3\text{F}_3\text{O}_2$ ): calcd. 200.008514; found. 200.008636. CHN (200.11): calcd. C 54.01, H 1.51; found. 54.17 H 1.63

### 21.7 1,2-Bis(ethanedioxy)-3-(trifluoromethyl)benzocyclobutene (177)

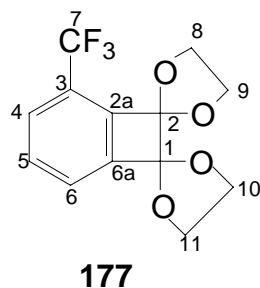

3.40 g (17.00 mmol) of 3-trifluoromethylcyclobenzocyclobutendione (**175**), 8.00 g (51.00 mmol) of ethane-1,2-diol and 200 mg (1.16 mmol) of *para*-toluenesulfonic acid in 150 mL of benzene were heated at reflux with azeotropic water removal. When no more water was liberated, the solvent and excess ethane-1,2-diol were removed at reduced pressure, and the residue was crystallized from ethyl acetate, yielding 3.2 g (11.00 mol, 65%) of **177** as colorless crystals (m. p. 154 °C).

**177** IR: (ATR):  $\tilde{\nu}$  = 2975(w)  $\text{cm}^{-1}$ , 2902 (w), 1615 (w), 1528 (w), 1477 (w), 1406 (w), 1345 (s, C-F), 1269 (s), 1222 (s), 1166 (m), 1126 (s, C-F), 1043 (s), 1042 (w), 949 (m), 897 (w), 756 (m), 687 (m). -  $^1\text{H}$  NMR(400.1 MHz,

acetone- $d_6$ ):  $\delta$  = 4.04 (m, 4H, 8-H + 9-H), 4.18 (m, 4H, 10-H + 11-H), 7.48 (d, 1H,  $^3J$  = 7.9 Hz, 4-H), 7.72 (d, 1H,  $^3J$  = 5.6 Hz, 4-H), 7.80 (dd, 1H,  $^3J$  = 6.3 Hz,  $^3J$  = 5.4 Hz, 4-H). -  $^{13}\text{C}$  NMR (100.6 MHz, acetone- $d_6$ , APT):  $\delta$  = 59.2 (+, C-2), 64.9 (+, C-10 + C-11), 65.4(+, C-8 + C-9), 71.8 (+, C-1), 121.2 (q, +,  $^1J_{\text{C-F}}$  = 271 Hz, C-7), 126.2 (d, +,  $^2J$  = 38 Hz, C-3), 126.3(-, C-6), 127.5 (-, C-5), 129.5(q, -,  $^3J_{\text{C-F}}$  = 4.0 Hz, C-4), 133.1 (+, C-2a), 146.9 (-, C-6a). - MS (70eV, 60 °C):  $m/z$  (%) = 287 (3)[ $\text{M}^+$ ], 261 (10), 244 (10), 216 (100) [ $\text{M}-\text{CF}_3-2\text{H}$ ], 197 (15), 172 (76), 144 (40), 125 (11), 108 (1), 91 (19), 75 (7). - CHN ( $\text{C}_{13}\text{H}_{11}\text{F}_3\text{O}_4$ ) 288.2227: calcd. C 54.17, H 3.85; found. C 54.19, H 4.39.

## 21.8 1,2-Bis(ethyldioxy)-3-(trifluoromethyl)-benzocyclobutene Complex 178

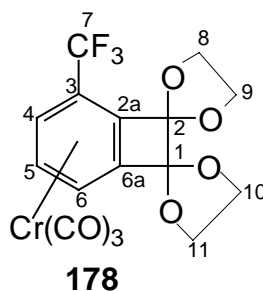

3.00 g (10.00 mmol) of **177** and 4.83 g (22.00 mmol) of hexacarbonylchromium in 150 mL of diethyl ether and 15 mL of THF were heated at reflux for 20 h. After cooling to 25°C and filtration through a 5 mm thick layer of silica gel eluting with THF the solvent was removed at reduced pressure. The residue was purified by column chromatography ( $\text{SiO}_2$ , 400 × 30 mm, TMBE/PE, 1:2), yielding 1.3 g (3.0 mmol, 30 %) of *rac*-**178** as yellow solid.

**178** IR: (ATR):  $\tilde{\nu}$  = 2975 (w)  $\text{cm}^{-1}$ , 2902 (w), 1990 (s, CO), 1976 (s, CO), 1906 (s, CO), 1615 (w), 1528 (w), 1477 (w), 1406 (w), 1345 (s, C-F), 1269 (s), 1222 (s), 1166 (m), 1126 (s, C-F), 1043 (s), 1042 (w), 949 (m), 897 (w), 756 (m), 687 (m). -  $^1\text{H}$  NMR(400.1 MHz, acetone- $d_6$ ):  $\delta$  = 4.05 (m, 4H, 10-H + 11-H), 4.18 (m, 4H, 8-H + 9-H), 5.54 (dd, 1H,  $^3J$  = 6.4 Hz,  $^3J$  = 6.4 Hz, 5-H), 5.92

(d, 1H,  $^3J = 5.6$  Hz, 4-H), 6.13 (d, 1H,  $^3J = 6.4$  Hz, 6-H). -  $^{13}\text{C}$  NMR (100.6 MHz, acetone- $d_6$ ):  $\delta = 64.8$  (+, C-8(9) or C-10(11)), 65.3 (+, C-8(9) or C-10(11)), 87.72 (-, C-6), 88.9 (-, C-5), 89.5 (q, -,  $^3J_{\text{C-F}} = 3.3$  Hz, C-4), 110.9 (+, C-1 or C-2), 111.5 (+, C-1 or C-2), 123.9 (q, +,  $^1J_{\text{C-F}} = 272$  Hz, C-7), 125.2 (+,d, +,  $^2J = 37$  Hz, C-3), 143.1 (+, C-2a), 146.8 (+, C-6a), 229.1 (+, CO). - MS (70eV, 80°C):  $m/z$  (%) = 424 (5)[ $\text{M}^+$ ], 368 (2) [ $\text{M}^+ - 2\text{CO}$ ], 340 (8) [ $\text{M}^+ - 3\text{CO}$ ], 269 (3), 244 (6), 216 (100) [ $\text{M} - 3\text{COCF}_3\text{H}$ ], 197 (11), 172 (63), 144 (26), 125 (8), 100 (7), 72(5)[Cr]. - HRMS ( $\text{C}_{16}\text{H}_{11}\text{CrF}_3\text{O}_7$ ): Calcd. C 423.986197; found 423.986115.

## E     **References:**

1. H. Finkelstein, *Chem. Ber.* **1910**, *43*, 1528-1529.
2. M. P. Cava, D. R. Napier, *J. Am. Chem. Soc.* **1956**, *78*, 500-501.
3. (a) J. L. Segura, N. Martin, *Chem. Rev.* **1999**, *98*, 3199-3246. b). H. Nemoto, K. Fukumoto, *Tetrahedron* **1998**, *54*, 5425-5464.
4. a) R. A. Finnegan, *J. Org. Chem.* **1964**, *30*, 1333-1335; b) A. Streitwiese, G. R. Ziegler, P. C. Mowery, A. Lewis, R.G. Lawler, *J. Am. Chem. Soc.* **1968**, *90*, 1357-1378.
5. Z. Galsovac, M. E. Maksic, K. M. Broadus, M. C. Hare, S. R. Kass, *J. Org. Chem.* **2000**, *65*, 1818-1824.
6. T. Kametani, K. Fukumoto, *Heterocycles* **1975**, *3*, 29-31.
7. F. R. Jensen, W. E. Coleman, A. J. Berlin, *Tetrahedron Lett.* **1952**, 15-16.
8. W. Oppolzer, K. Keller, *J. Am. Chem. Soc., Chem. Commun.* **1976**, 400-401.
9. T. Kametani, H. Nemoto, K. Fukumoto, *J. Chem. Soc., Chem. Commun.* **1976**, 400-401.
10. a) T. Kametani, Y. Kato, T. Honda, K. Fukumoto, *Heterocycles*, **1976**, *4*, 241; b) *J. Am. Chem. Soc.*, **1976**, *98*, 8185-8190.
11. T. Kametani, Y. Hirai, F. Satoh, K. Fukumoto, *J. Chem. Soc., Chem. Commun.* **1977**, 16-18.
12. a) T. Kametani, H. Nemoto, H. Ishikawa, K. Shiroyama, K. Fukumoto, *J. Am. Chem. Soc.* **1976**, *98*, 3378; b) T. Kametani, H. Nemoto, H. Ishikawa, K. Shiroyama, H. Matsumoto, K. Fukumoto *ibid* **1977**, *99*, 3461-3380.
13. H. Nemoto, K. Fukumoto, *Tetrahedron* **1998**, *54*, 5425-5464.
14. J. L. Segura, N. Martin, *Chem. Rev.* **1999**, *99*, 3199-3246.
15. J. L. Charton, M. M. Alauddin, *Tetrahedron* **1987**, *43*, 2873-2889.
16. W. Oppolzer, *Synthesis* **1978**, 793- 802.
17. R. L. Funk, K. P. C. Vollhardt, *Chem. Soc. Rev.* **1980**, 41.

18. a) H. Huisgen, H. Seidl, *Tetrahedron Lett.* **1964**, 3381-3382; b) G. Quinkert, K. Opitz, W. W. Wiersdorff, M. Finke, *Justus Liebigs Ann. Chem. Rev* **1970**, 70, 693-694.
19. a) J. D. Morrison, H. S. Mosher, *Asymmetric Organic Reaction*, Prentice-Hall. Englewood Cliffs, NJ, **1971**. (b) Morrison, Mosher, *ibid.* **1971**, 6-7.
20. E. P. Kündig, G. Bernardinelli, J. Leresche, *J. Chem. Soc, Chem. Commun.* **1991**, 1713-1715.
21. E. O. Fischer, K. Öfele, *Chem. Ber.* **1957**, 90, 2532-2535.
22. a) S Top, G. J Jaouen, *Organomet. Chem.* **1979**, 182, 381-383; b). C. A. L. Mahaffy, P. L. Paoson, *Inorg. Synth.* **1979**, 19,154-155.
23. M. F. Semmelhack, *J. Organomet. Chem. Lib.*, **1976**, 1, 361-139.
24. a) F. R-Munch, E. Rose, *Curr. Org. Chem.* **1999**, 3, 445 -467; b) A. R. Pape, K. P. Kaliappan, E. P. Kündigs, *Chem. Rev.* **2000**, 100, 2917-2940.
25. R. J. Card, W. S. Trahanovsky, *Tetrahedron Lett.* **1973**, 3823-3824; M. F. Semmelhack, W. Wulff, J. L. Garcia, *J. Organomet. Chem.* **1982**, 240; c) A. P. Kozikoski,; R. J. Isobe, *Chem. Soc., Chem. Commun.* **1978**, 1076-1077.
26. a) R. J Card, W. S. Trahanovsky, *J. Org. Chem.* **1980**, 45, 2555- 2566; b) M. F. Semmelhack, J Bisaha, M. Czarny, *J. Am. Chem. Soc.* **1979**, 101. 768-770; c) G Jaouen, A. Mayer, G. J. Simmonneaux, *Chem. Soc. Chem. Commun.* **1975**, 813-814.
27. S. Top, G. Jaouen, *J. Org. Chem.* **1981**, 46, 78-82.
28. S. G. Davis, T. D. McCarthy, *Comprehensive Organometallic Chemistry II*, L. S. Hegedus, Ed, W.E. Abel, F. G. A. Stone, G. Wilkinson, Ed, Elsevier Science, Oxford, **1995**, 12, 1017-1038. 28a) K. H. Dötz *Angew. Chem.* **1984**, 96, 573-594; *Angew. Chem. Int. Ed Engl.* **1984**, 23, 587-608.
29. Solladie-Cavallo, *Advances in Metal-Organic Chemistry*; Ed. L. S. Liebeskind, Jai Press. Inc. **1980**, 99-131.

30. a) A. Solladie-Cavallo, G. Solladie, E. Tsama, *J. Org. Chem.* **1979**, *44*, 4189-4191. b) L. A. Bromley, S. G. Davis, C. L. Goodfellow, *Tetrahedron: Asymmetry* **1991**, *2*, 139-156; c) A. Alexakis, P. Mangeney, I. Mare, F. Rose-Munch, E. Rose, A. Semra, F. Robert, *J. Am. Chem. Soc.* **1992**, *114*, 8288-8290.
31. K. Nakamura, K. Ishihara, A. Ohno, M. Umemura, H. Nishimura, Y. Hayashi, *Tetrahedron* **1990**, *31*, 3603 - 3604.
32. M. F. Semmelhack, *Comprehensive Organometallic Chemistry II*, E. W. Abel, F.G. A. Stone, G. Wilkinson, Pergamon, Oxford **1995**, *12*, 979-1015.
33. S. Sur, S. Ganesh, V. G. Puranik, A. Sarkar, *J. Chem. Soc., Perkin Trans. I* **1998**, 977-982.
34. D. Hörstermann, H. G. Schmalz, G. K. Köhn, *Tetrahedron* **1999**, *55*, 6905-6916.
35. K. Kamikawa, T. Watanabe, A. Daimon, M. Umura, *Tetrahedron* **2000**, *56*, 2325-2337.
36. a) W. A. Denny, *Cancer Chemotherapeutic Agents*, Foye, W.O. ed., ACS, Washington **1995**, 483-500. b) B. J. Graham, G. Mustafa, J. E. Mathews, *Tetrahedron Lett.* **2000**, *41*, 1123-1126.
37. a) J. Tanaka, N. Ogawa, J. Liang, T. Higa, D.G. Gravalos, *Tetrahedron* **1993**, *49*, 811. b) T. Geller, J. W. Bats, H. G. Schmalz, *Tetrahedron Lett.* **1998**, *39*, 1537-1540.
38. W. Gschwend, H. R. Rodriguez, *Org. React.* **1979**, *26*,1.
39. a) J. Blagg, S. G. Davis, C. L. Goodfellowand, K. H. Shutton, *J. Chem. Soc., perk. Trans. 1*, **1987**, 1805-1811; b) J. A. Heppert, M. E. Thomas-Miller, M. L. Milligan, D. Vander Velde, J. Aubé, *Organometallics* **1988**, *7*, 2581-2584; c) M. Uemura, R. Miyake, H. Nishimura, Y. Matsumoto, T. Hayashi, *Tetrahedron Asymmetry* **1992**, *3*, 213-216.
40. M. F. Semmelhack, G. R. Clark, J. L. Garcia, J. J. Harrison, Y. Thebtaranonth, W. Wulff, A. Yamashita, *Tetrahedron* **1981**, *37*, 3957.

41. Hans G. Wey, H. Butenschön, *Angew. Chem.* **1991**, *103*, 871-873; *Angew. Int. Ed. Engl.* **1991**, *30*, 880-881.
42. M. Brands, H. G. Wey, R. Krömer, C. Krüger, H. Butenschön, *Liebigs Ann.* **1995**, 253- 265.
43. E. P. Kündig, J. Leresche, L. Saudan, G. Bernardinelli, *Tetrahedron* **1996**, *52*, 7363-7378.
44. M. Brands, H. G. Wey, R. Goddard, H. Butenschön, *Inorg. Chem. Acta* **1994**, *220*, 175-186.
45. E. P. Kündig, G. Bernardinelli, J. Leresche, *J. Chem. Soc. Chem. Commun.* **1991**, 1713-1715.
46. M. Brands, R. Goddard, H. G. Wey, H. Butenschön, *Angew. Chem.* **1993**, *105*, 285-287; *Angew. Int. Ed. Engl.* **1993**, *32*, 267-269.
47. L. A Paquette, T. Morwick, *J. Am. Chem. Soc.* **1995**, *117*, 1451-1452.
48. Römpp Lexikon, *Naturstoffe*, Thieme, Stuttgart, **1997**.
49. a) M. P. Cava, K. Muth, *J. Am Chem. Soc.* **1960**, *82*, 652-654; b) H. Hart, R. W. Fish, *J. Am. Chem. Soc.* **1960**, *82*, 749-750; c) H. Hart, J. A. Hartlage, R. W. Fish, R. R. Rafos, *J. Org. Chem.* **1966**, *31*, 2244-2250; d), I. S. Aidhen, J. R. Ahuja, *Tetrahedron* **1992**, *33*, 5431-5432.
50. E. Hedaya, M. E. Kent, *J. Am. Chem. Soc.* **1970**, *92*, 2149; b) R. J. Spangler, J. H. Kim, *Tetrahedron Lett.* **1972**, *13*, 1249-1251; c) P. Schiess, M. Heitzmann, *Angew. Chem.* **1977**, *89*, 485-485; *Angew. Chem. Int. Ed. Engl.* **1977**, *16*, 469-469.
51. T. Hosoya, T. Hasegawa, Y. Kuriyama, T. Matsumoto, K. Suzuki, *Synlett* **1995**, 177-179.
52. R. V. Stevens, G. S. Bisacchi, *J. Org. Chem.* **1982**, *47*, 2393-2396.
53. S. M. McElvain, D. Kundiger, *Org. Synth. Coll. Vol.3*, Wiley, **1955**, 506-507.
54. S. M. McElvain, D. Kundiger, *Org. Synth. Coll. Vol.3*, Wiley, **1955**, 123-125.
55. R. F. C. Brown, F. W. Eastwood, G. L. McMullen, *J. Chem. Soc. Chem. Comm.* **1975**, 328-329.

56. T. Hosoya, T. Hamura, Y. Kuriyama, M. Miyamoto, T. Matsumoto, K. Suzuki, *Synlett* **2000**, 520-522.
57. M. S. South, L. S. Liebeskind, *J. Org. Chem.* **1982**, *47*, 3815-3821.
58. L. S. Liebeskind, L. J. Lescosky, C. M. McSwain, *J. Org. Chem.* **1989**, *54*, 1435-1439.
59. M. Schnebel, *Unpublished results*.
60. R. Davis, L. A. Kane-Maquire, *Comprehensive organometallic chemistry*, Ed G. Wilkinsion, Oxford, Pergamon Press, **1982**, *3*, 1001-1077.
61. a) K. G. Dongol, J. Krüger, M. Schnebel, B. Voigt, R. Wartchow, H. Butenschön, *Inorg. Chem. Acta* **1999**, *296*, 150-157. b) J. Krüger, *Diplom thesis*, University of Hannover, **1995**.
62. K. G. Dongol, M. Schnebel, R. Wartchow, H. Butenschön, *Unpublished results*.
63. L. Horner, P. V. Subramaniam, K. Eiben, *Liebigs Ann. Chem.* **1968**, *714*, 91-111.
64. a) S. Hshiguchi, A. Fujii, J. Takehara, T. Ikariya, R. Noyori, *J. Am. Chem. Soc.* **1995**, *117*, 7562-7563; b) A. Fujii, S. Hashiguchi, N. Uematsu, T. Ikarya, R. Noyori, *J. Am. Chem. Soc.* **1996**, *118*, 2521-2522.
65. I. Weidner, *Unpublished Results*.
66. a) H. G. Hey, H. Butenschön, *Angew. Chem.* **1991**, *103*, 871; *Angew. Chem., Int. Ed. Engl.* **1991**, *30*, 880.
67. G. Jaouen, A. Meyer, *J. Am. Chem. Soc.* **1975**, *97*, 4667-4668.
68. Hans G. Wey, P. B. Betz, H. Butenschön, *Chem. Ber.* **1991**, *124*, 465-474.
69. a) B. J. Arnold, P. G. Sammes, T. W. Wallace, *J. Chem. Soc. Perkin Trans. I* **1974**, 415- 420. b) B.J. Arnold, P.G. Sammes, *J. Chem. Soc. Chem. Comm.* **1972**, 1034-1035.
70. K. Kobayashi, M. Kawakita, M. Uchida, K. Nishimura, T. Mannami, S. Irisawa, O. Morikawa, H. Konishi, *J. Org. Chem.* **1999**, *64*, 3557-3562.



71. H. Ziehe, R. Wartchow, H. Butenschön, *Eur. J. Chem.* **1999**, 823-835.
72. M. Hesse, H. Meier, B. Zeeh, *Spectroscopic Methods in Organic Chemistry*, Thieme, **1997**.
73. A. Gokhale, P. Schiess, *Helv. Chim. Acta* **1998**, 81, 251-267.
74. H. Ziehe, *Doctoral thesis*, University of Hannover, **1998**
75. a) J. R. Wiseman, J. J. Pendery, C.A. Otto, K. G. Chiong, *J. Org. Chem.* **1980**, 45, 516-519; b) M. Azadi-Ardakani, T. W. Wallace, *Tetrahedron* **1988**, 44, 5939- 5952.
76. W. Choy, H. Yang, *J. Org. Chem.* **1988**, 53, 5796-5798.
77. a) P.G. Sammes, *Tetrahedron* **1976**, 32, 405-422; b) C.W. Jefford, G. Barnardinelli, Y. Wang, D.C. Spellmeyer, A. Buda, K.N. Houk, *J. Am. Chem.* **1992**, 114, 1157-1165.
78. D. Wittneben, H. F. Grützmacher, H. Butenschön, H. G. Wey, *Organometallics*, **1992**, 11, 3111-3116.
79. E. P. Kündig, J. Leresche, *Tetrahedron* **1993**, 49, 5599-5615.
80. J. L. Charton, S. Maddaford, K. Koh, S. Boulet, M. H. Saunders, *Tetrahedron* **1993**, 4, 645-648.
81. J. L. Charton, K. Koh, *Synlett* **1990**, 333-334.
82. C. W. G. Fishwick, D. W. Jones, *The chemistry of Quinonoid compounds*, eds; S. Patai, Z. Rappoport, Wiley, New York, **1988**, 403-453.
83. M. B. Smith, *Organic Synthesis McGraw-Hill International* ed. **1994**.
84. T. Kametani, M. Tsubuki, Y. Shiratori, Y. Kato, H. Nemoto, M. Ihara, K. Fukumoto, *J. Org. Chem.* **1977**, 42, 2672-2676.
85. W. R. Roush, *Comprehensive Organic Synthesis*, Ed B. M. Trost, 5, Pergamon, oxford, **1991**, 513.
86. H. Nemoto, K. Fukumoto, *Tetrahedron*, **1998**, 54, 5425-5464.
87. J. J. Fitzgerald, F. E. Michael, R.A. Olofson, *Tetrahedron Letts.* **1994**, 35, 9191-9194.
88. L. A. Paquette, *Tetrahedron*, **1997**, 53, 13971-14020.
89. D. A. Evans, A. M. Golob, *J. Am. Chem. Soc.* **1975**, 97, 4765-4766.

90. D. A. Evans, D. J. Baillargeon, *Tetrahedron Lett.* **1978**, *36*, 3315-3318;  
b) M. L. Steigerwald, W. A. Goddard III, D. A. Evans, *J. Am. Chem. Soc.* **1979**, *101*, 1994-1997; c) M. J. S. Dewar, C. Jie, *J. Am. Chem. Soc.* **1987**, *109*, 5893- 6900.
91. D. A. Evans, D. J. Baillargeon, *Tetrahedron Lett.* **1978**, *36*, 3319-3322.
92. M. D. Roeboom, J. P. Kiplinger, J. E. Bartmess, *J. Am. Chem. Soc.* **1984**, *106*, 1025-1029.
93. G. Ahlgren, *Tetrahedron Lett.* **1979**, *10*, 915-918; b) B. K. Carpenter, *Tetrahedron* **1978**, *34*, 1877-1884.
94. J. T. Negri, T. Morwick, J. Doyon, P. D. Wilson, E. R. Hickey, L. A. Paquette, *J. Am. Chem. Soc.* **1993**, *115*, 12189-12190.
95. M. Brands, J. Bruckmann, C. Krüger, H. Butenschön, *J. Chem. Soc., Chem. Commun.* **1994**, 999-1000.
96. M. Brands, H.G. Wey, J. Bruckmann, C. Krüger, H. Butenschön, *Chem. Eur. J.* **1996**, *2*, 182-190.
97. M. Brands, H. G. Wey, H. Butenschön, *J. Chem. Soc., Chem. Commun.* **1991**, 1541-1542.
98. H. Butenschön, B. Gabor, R. Mynott, H.G. Wey, *Z. Naturforsch.* **1995**, *50b*, 483-487.
99. K. G. Dongol, J. Krüger, M. Schnebel, B. Voigt, R. Warchow, H. Butenschön, *Inorg. Chim. Acta* **1999**, *296*, 150-157.
100. L. A. Paquette, T. Morwich, *J. Am. Chem. Soc.* **1995**, *117*, 1451-1452;  
b) L. A. Paquette, J. Doyon, *J. Am. Chem. Soc.* **1995**, *117*, 6799-6800.
101. C. H. Heathcock in *Comprehensive Organic Synthesis*; N. M. Trost, I. Fleming, Ed.; Pergamon Press, Oxford, **1991**, *2*, 133-179.
102. L. Paquette, T. M. Morwick, *J. Am. Chem. Soc.* **1997**, *119*, 1230-1241.
103. K. C. Nicolaou, N. A. Petasis, R. S. Ziplin, J. Uenishi, *J. Am. Chem. Soc.* **1982**, *104*, 5555- 5558.
104. B. Viogt, M. Brands, R. Goddard, R. Wartchow, H. Butenschön, *Eur. J. Org. Chem.* **1998**, 2719-2727.
105. H. Butenschön, *Synlett* **1999**, *6*, 680-691.

106. L. A. Paquette, *Tetrahedron* **1997**, *53*, 13971-14020.
107. C. Clausen, R. Wartchow, H. Butenschön, *Eur. J. Org. Chem.* **2001**, 93-113.
108. S. Hoff, L. Brandsma, J. F. Arens, *Recl. Trav. Chim. Pays-Bas* **1968**, *87*, 916-924 and 1179-1184.
109. R. Zimmer, *Synthesis* **1993**, 165-178.
110. E. A. Braude, E. A. Evans, *J. Chem. Soc.* **1956**, *3*, 3333-3337.
111. L. A. Paquette, *Eur. J. Org. Chem.* **1998**, 1709-1728.
112. L. A. Paquette, T. M. Morwick, J. T. Negri, R. D. Rogers, *Tetrahedron* **1996**, *52*, 3075-3094.
113. B. Voigt, R. Wartchow, H. Butenschön, *Eur. J. Chem.* **2000** submitted.
114. B. Voigt *Doctoral thesis*, University of Hannover, **1997**.
115. R. L. Danheiser, C. Martinez-Davila, J. M. Morin, Jr., *J. Org. Chem.* **1980**, *45*, 1340-1341.
116. E. Palomino, A. P. Schaap, M. J. Heeg, *Tetrahedron Lett.* **1989**, *30*, 6797-6800.
117. L. Brandsma, H. Verkruijsse, *Preparative Polar Organometallic Chemistry I*, Springer, Heidelberg, **1987**, 63.
118. W. C. Still, M. Kahn, A. Mitra, *J. Org. Chem.* **1978**, *43*, 2923-2925.
119. *Anfärbereaganzien für Dünnschicht- und Papierchromatographie*, E. Merck, Darmstadt, **1970**.
120. H. Günther, *NMR-Spektroskopie*, 2. Auf., Thieme, Stuttgart **1983**, 52.
121. a) F. J. Weinbert, *J. Org. Chem.* **1985**, *50*, 5308-5309; b) J. Reppe, *Liebigs Ann. Chem.*, **1955**, *596*, 1-224.
122. H. Gilman, J.W. Morton Jr., *Organic reactions*, **1954**, *8*, 286.
123. D. Seyferth, M. A. Weiner, *J. Am. Chem. Soc.* **1961**, *83*, 3583-3586.
124. K. Mori, T. Otsuka, M. Oda, *Tetrahedron* **1984**, *40*, 2929-2934. - b) H. K. Reimshüssel, *J. Org. Chem.* **1960**, *25*, 2256-2257.
125. T. A. Miller, *J. Org. Chem.* **1988**, *53*, 2214-2220.
126. a) U. Schöllkopf, P. Häble, *Liebigs Ann. Chem.* **1972**, *763*, 208-210; b) M. Shimano, A. L. Meyers, *J. Am. Chem. Soc.* **1994**, *116*, 10815-10816;

- c) R.H. Wollenberg *Tetrahedron Lett.* **1978**, 8, 717-720; d) K. Sorger, W. Bauer, P. V. R. Schleyer, D. Stalke, *Angew. Chem.* **1995**, 107, 1766-1768, *Angew. Chem. Int. Ed. Engl.* **1995**, 34, 1594-1596.
127. a) F.J. Weinbert, *J. Org. Chem.* **1985**, 50, 5308-5309; b) J. Reppe, *Liebigs. Ann. Chem.* **1955**, 595, 1-224.
128. a) L. A. Paquette, J. F. P. Andrews, C. Vanucci, D. E. Lawhorn, J. T. Negri, *J. Org. Chem.* **1992**, 57, 3956-3965; b) P. J. Kocienski, M. Pritchard, S. N. Wadman, R. J. Whitby, C. L. Yeates, *J. Chem. Soc. Perkin Trans. 1*, **1992**, 3419-3429.
129. L. F. Cason, H. G. Brooks, *J. Org. Chem.* **1952**, 19, 1278-1282.

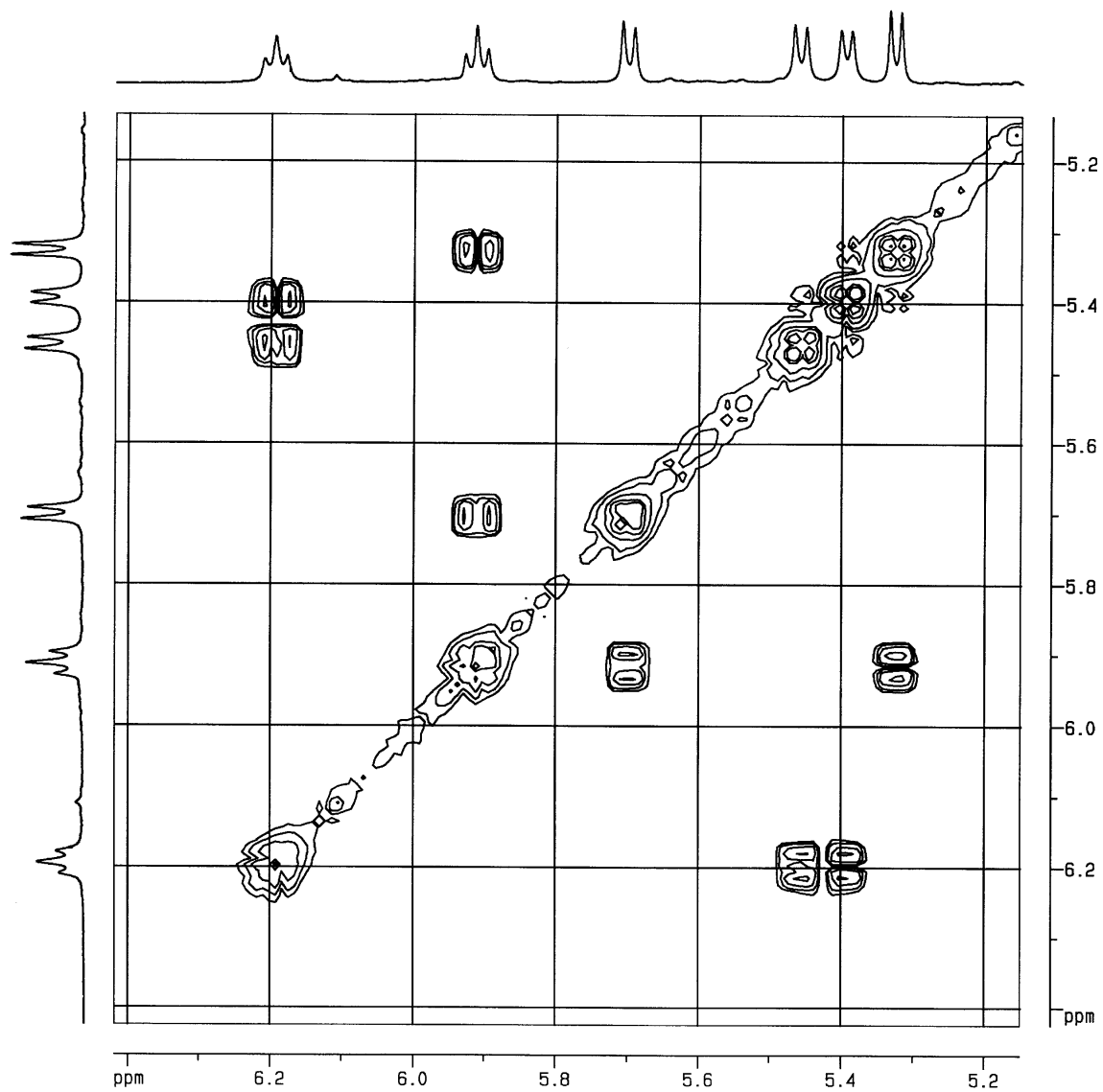

COSY from mixture of complexes **153** and **154**

## Curriculum vitae

Name: Krishna Gopal Dongol  
Date of Birth: 19 Janaury 1968  
Marital Status: Married with Laxmi Nani Maharjan since 1997  
Parents : Indra Lal Dongol and Laxmi Davi Dongol

### Academic qualification:

1984 School leaving certificate (SLC) from Jana Sewa Secondary school Panga, Kathmandu, Nepal  
1987 Intermediate in Science from Amrit Campus, Tribhuvan University, Kathmandu, Nepal  
1987-1988 Bachelor degree in Science from Tri-chandra Campus, Tribhuvan University, Kathmandu, Nepal  
1990-1992 Master Degree in Science from Central Dept. of Chemistry, Tribhuvan University, Kathmandu, Nepal  
4/1998-4/2001 Doctoral Degree in Organic Chemistry in Institute für Organische Chemie, University of Hannover, Hannover, Germany, under the supervision of Prof. Dr. H. Butenschön. Thesis: Methoxy and trifluoromethyl substituted benzocyclobutenone and -butenedione Complexes.

### Experiences:

1997-2001 **Lecturer**, Tribhuvan University, Kathmandu, Nepal.  
1994-1996 **Assistant Lecturer**, Tribhuvan University, Kathmandu, Nepal.  
1997-1998 **Chemist and Environmental consultant**, in Institute for Legal Research and Resource (ILRR), Kathmandu, Nepal.  
1996-1997 **Research Assistant**, The World Conservation Union, IUCN, Nepal.  
1992-1994 **Dyeing Chemist**, Kathmandu Dyeing (P) Ltd., Kathmandu, Nepal.  
1988-1989 **Secondary Science Teacher**, Panga Secondary School, Kathmandu

**Award:** Doctoral fellowship in chemistry from "**Gottlieb Daimler und Karl Benz-Stiftung**", Germany

**Reference:**

Prof. Dr. Holger Butenschön  
Institute für Organische Chemie  
Universität Hannover  
Schneiderberg 1B  
D-30167 Hannover  
Germany  
Tel: +49/511/762-4661, - 4662  
Fax: +49/511/762-4616  
Email: [holger.butenschoen@mbox.oci.uni-hannover.de](mailto:holger.butenschoen@mbox.oci.uni-hannover.de)