

Martin Bensch*, Marc Müller, Michael Bode and Birgit Glasmacher

Automation of a test bench for accessing the bendability of electrospun vascular grafts

DOI 10.1515/cdbme-2016-0068

Abstract: One of the greatest challenges in cardiovascular tissue engineering is to develop vascular grafts with properties similar to autologous vessels. A promising approach is the fabrication of scaffolds from biodegradable polymers by electrospinning. Unstructured vascular subs possess a weak dimensional stability resulting in lumen collapse when subjected to bending stress. In order to examine different structured grafts, a standardised test method is required. A manual test method, designed in a former study, was adopted in terms of standardisation and automation. Therefore, a control system was programmed to regulate the required electronics. The electronic circuit was then developed and put into service. To fix samples into the test bench a new sample holder and a new collector for electrospinning were designed. Subsequently, a validation showed the new systems' improved functionality compared to the former test bench. The samples were manufactured with the new collector. They could be fixed to the sample holder with high repeatability. The demand for vascular grafts with biological and mechanical properties similar to autologous vessels requires a standardised test method to examine bendability. The new test system enables the scaffolds to be examined regarding bendability with low personal expense and a simultaneously high degree of reproducibility. In addition, the new collector geometry can be easily adapted to higher or lower inner diameters. Hence, a new sample geometry was developed within this work.

Keywords: bendability; biodegradable polymers; electrospinning; test bench; Tissue engineering; vascular grafts.

1 Introduction

The major cause of death in developed countries is atherosclerosis [1]. Surgery often remains as the last

treatment option [2]. If autologous prosthesis' cannot be used, commercial synthetic grafts must be applied [3]. However, these do not have biological and mechanical properties similar to autologous vessels. To meet the growing demand for vascular grafts, tissue engineering has emerged as a viable option [4–7]. A promising approach is to spin biodegradable polymers with electrospinning [8]. Such vascular grafts have to be optimised in terms of their mechanical properties. Studies show that the lumen collapses under bending stress [9]. One approach is to modify the sample geometry by structuring the surface (called pleating) [10]. To compare different geometries based on their bendability, a standardised test method is required. In a former study a suitable manual test bench was designed. The use of silicon for the preparation of samples (Figure 1) resulted in a large processing time spanning multiple hours. Furthermore, preparation and fixation of samples into the test bench showed an improved level of reproducibility (e.g. torsional stress). The test method was difficult and the measurement error depended on the user. To examine a single sample geometry, up to 26 measurements had to be taken. This made loss of data more likely because all the values were not digitally recorded. The former sample holder lead to torsional stress on samples, because it did not geometrically limit the samples' rotational degree of freedom. This caused non-reproducible measurement errors and made an accurate comparison more complicated. In context of standardisation, a reproducible way to fix vascular grafts into the test bench is required. For automation, a micro controller was programmed, the design was prepared with suitable electronic devices and the system's functionality was validated.

2 Material and methods

2.1 Design of flow bending test bench

To automate the manual test method, a new test bench had to be designed. Figure 2 shows the designed test bench in isometric view. It consists of a step motor housing, guide rail, bending cylinder, two sample holders,

*Corresponding author: Martin Bensch, Institute of Multiphase Processes, Leibniz Universität Hannover, Callinstr. 36, 30167 Hanover, Germany, E-mail: Martin.Bensch@stud.uni-hannover.de
Marc Müller, Michael Bode and Birgit Glasmacher: Institute of Multiphase Processes, Leibniz Universität Hannover, Callinstr. 36, 30167 Hanover, Germany

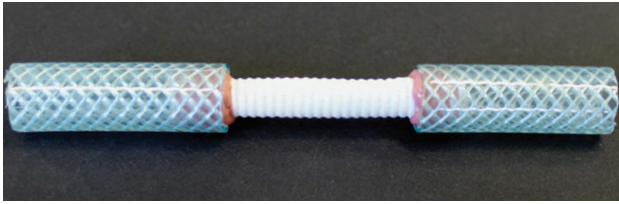

Figure 1: Prepared sample for the manual test bench. Endings and tube pieces are joint together with silicon.

coupling, gear stage and guide arm. The moveable sample holder moves in two guide rails (2) which allow bending angles between 0° and 140° degrees. Its motion is forced by a guide arm which is connected to the step motor over a gear stage. The sample holders themselves each consist of a connector (Figure 3) which is clamped into the holder system. Ending 1 of the connector has a similar geometry as the sample endings, to improve the positioning accuracy of the samples as well as reproducibility. Ending 2 of the connector is connected to the tube network. However, through the bending cylinder (3), the vascular grafts are forced to kink at that defined point and are supported during bending (results in more comparable test results). The coupling (5) connects the moveable sample holder with the tube network and allows removal of the connector.

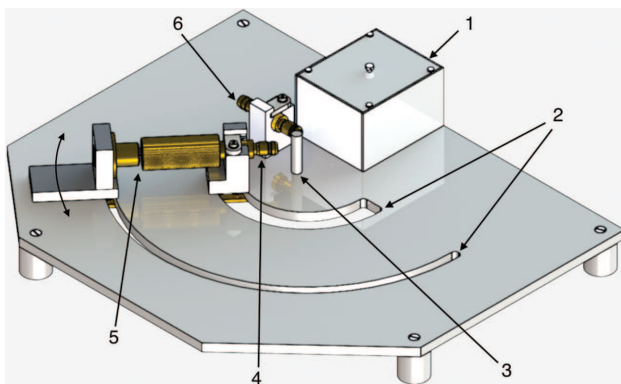

Figure 2: Test bench without prosthesis. (1) Step motor housing (2) guide rail (3) bending cylinder (4) movable sample holder (5) coupling to periphery (6) fixed sample holder.



Figure 3: Connector to clamp samples into the test bench. Ending 1 is permanently connected to the tube networks. Vascular grafts are fixed on ending 2.

2.2 Design of collector

Due to the importance of standardised mounting samples onto the test bench, a new collector for electrospinning was designed (Figure 4). Ending one (1) is rigidly connected to the shaft (3) and the remaining components are placed onto the shaft and fixed (4). The sleeve (6) has the particular pleating, in this case it is an unstructured sleeve. For a higher reproducibility regarding fixing, the new samples show marks on each ending to support the orientation while fixing them into the test bench. To spin the marks at the correct position, a mounting aid was developed, allowing the endings of the collector to be oriented to each other always in the same way.

2.3 Data processing

Before the control system and the electronic circuit were developed, a concept had to be found. Figure 5 shows the concept of the test system. After the control system opens the solenoid valve the fluid flows through the vascular graft and then passes the flow sensor. One series of measurements per bending angle consists of 60 measurements and takes 1 min. The microcontroller has a limited storage unit; hence all 60 measurements are written to the SD-Card after every series of measurements. Furthermore, a liquid crystal display (LCD) informs the user about the current bending angle and shows the least determined volume flow. Before a new measurement is done, the stepper forces the moveable sample holder to a new bending angle. In addition, to embed the test bench into a circulatory system

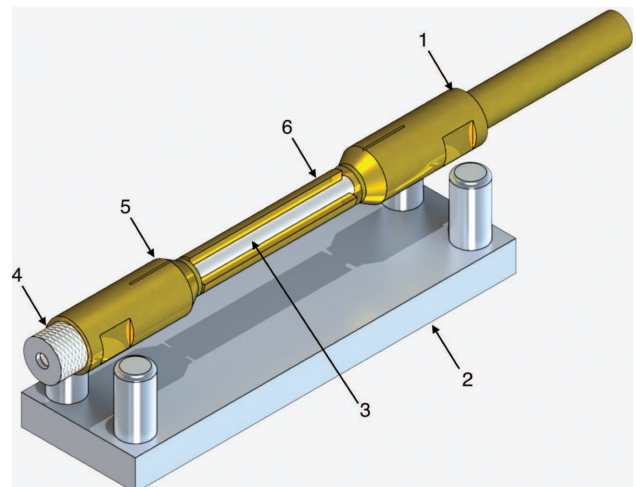

Figure 4: New collector for electrospinning with mounting aid. (1) Ending one (2) mounting aid (3) shaft (4) nut (5) ending two (6) sleeve.

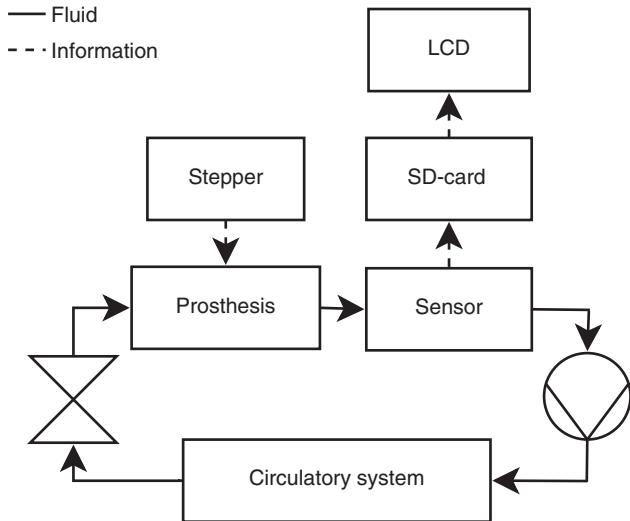

Figure 5: Continuous lines show the fluid's stream and dotted lines represent a flow of information.

a pump can be connected easily to the test bench. The system control runs on a microcontroller of an Arduino Mega 2560 and is programmed in *Processing*. According to fluid mechanics, a small diameter increases friction and decreases volume flow. The inner diameters of the samples have to be smaller than of the tube networks. To receive more meaningful results, the influence of the vascular grafts on the flow rate should be higher than that of the tube networks. Regarding the flow sensor, a diameter higher than 7 mm and a measuring range between 1.5 and 5 l/min are needed. The flow sensor outputs a square wave with 1000 pulses/l. To register the sensor signal, the relevant wire is connected to an interrupt pin of the microcontroller. The related interrupt service routine increments a variable called `pulsesFlowSensorDrain` every time a rising edge is recorded at this interrupt pin. To measure volume flow, the integer variable `pulsesFlowSensorDrain` is set to zero and afterwards the method `myFlowSensorDrain.measureFlow()` is called. This method enables interrupts, waits 1000 ms and then disables interrupts. During this time period the pulses variable is incremented via interrupt and after the interrupts have been disabled the recorded amount of pulses is stored into an array (which holds all measurements for one bending angle) and interrupts are enabled again. The process is repeated 60 times unless an error occurs (e.g. sample bursts, the emergency switch is pressed). The measurement data is stored in a text file on a SD-card and a measurement-protocol file holds information about the whole process (opening valve, possible errors and so on).

3 Results

At first, three samples were spun with the new collector. Every sample showed the expected geometry. Because of that, samples were clamped into the test bench with a high reproducibility. Furthermore, the preparation took < 10 min, because silicon is no longer needed. Subsequently, stepper and flow sensor had been examined separately and afterwards the functional efficiency of the system was verified in the course of a test run. Regarding the stepper, a positioning accuracy of 1° per 140° was determined (Figure 6). The angles were measured with a goniometer by measuring deflection of the mobile sample holder for each position. This verification was made three times and showed the same results each time. After examining the stepper, the flow sensor had been validated regarding its repeat and measurement accuracy. Therefore, different volume flows were measured and the fluid was collected in a vessel. During the measurement, time was stopped and afterwards the vessel was weighed and temperature was determined. With this data the volume flow was calculated. Figure 7 shows, in the relevant range between 1.5 and 4 l/min the flow sensor induces almost constant discrepancy around 5%. This results fit with the sensor data-sheet. Since sensor, stepper and collector were validated in isolation, the interaction between these components had to be examined. The control system opened and closed (at minimum volume flow) the solenoid valve as expected and the volume flow was measured for different bending angles, too. Lastly, the error routines were

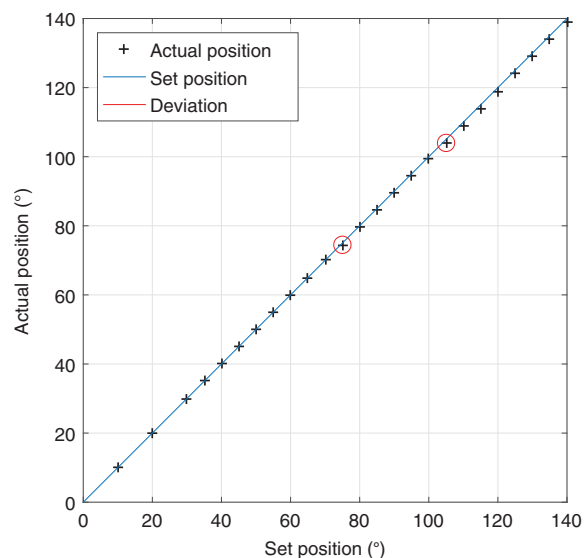

Figure 6: Steppers positioning accuracy, actual position compared to set position. Circles highlight step losses.

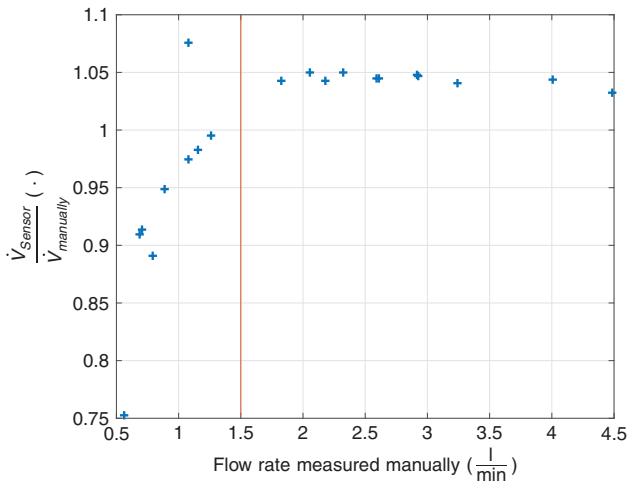

Figure 7: Volume flow measured by sensor compared to manually determined volume flow at different flow rates. Red line signals beginning of relevant measurement range.

tested successfully. After the process, all measurements could be found into the measurement file on the SD-card as well as the protocol file.

4 Conclusion and outlook

Implantations of extraneous vascular grafts are constantly increasing. One approach to meet the demand is to fabricate biodegradable polymer grafts with electrospinning. To examine the vascular grafts regarding their bendability, a test method is required. Within this work, the former manual test bench was optimised and automated. This contained a further design including a new collector, programming of a control system and the development of an electronic circuit. One the aims was to better fix samples onto the test bench (higher reproducibility, faster preparation, no use of silicon). The validation of the new sample holder and collector showed a magnificent improvement regarding reproducibility and the amount of time for preparation. While preparing samples for the manual test bench took multiple hours, now it can be fixed onto the automated test bench in < 10 min. It was shown, that the flow sensor and step motor operate with high accuracy. Furthermore, the test bench can be implemented into a fluid circuit driven by a pump. For the implementation of

this, a pump can be connected easily to the system. The automated test bench shows a high degree of automation and reproducibility, due to which the personal expense was sharply reduced. Overall, in the course of this work, an automated and standardised test bench for accessing the bendability of vascular grafts was successfully developed and realised.

Author's Statement

Research funding: The author state no funding involved.
Conflict of interest: Authors state no conflict of interest.
Material and Methods: Informed consent: Informed consent is not applicable. Ethical approval: The conducted research is not related to either human or animal use.

References

- [1] Wang ZT, Wang Z, Hu YW. [Possible roles of platelet-derived microparticles in atherosclerosis](#). *Atherosclerosis*. 2016;248:10–16.
- [2] Eikelboom BC. Efficacy of oral anticoagulants compared with aspirin after infrainguinal bypass surgery. *Lancet*. 2000;9201:346–51.
- [3] Wintermantel E, Ha S-W. *Medizintechnik*. Life science engineering. 4. Auflage. Berlin Heidelberg: Springer, 2008;44:S.1012.
- [4] Szentivanyi A, Chakradeo T, Zernetsch H, Glasmacher B. Electrospun cellular microenvironments. *Adv Drug Deliv Rev*. 2011a;63:209–20.
- [5] Szentivanyi A, Zernetsch H, Menzel H, Glasmacher B. A review of developments in electrospinning technology. *Int J Artif Organs*. 2011;34:986–97.
- [6] Pfeiffer D, Stefanitsch C, Wankhammer K, Müller M, Dreyer L, Krolitzki B, et al. Endothelialization of electrospun polycaprolactone (PCL) small caliber vascular grafts spun from different polymer blends. *J Biomed Mater Res A*. 2014;102:4500–9
- [7] Ravi S, Chaikof EL. Biomaterials for vascular tissue engineering. *Regen Med*. 2010;5:107–20.
- [8] Duling RR, Dupaix RB, Katsube N, Lannutti J. Mechanical characterization of electrospun polycaprolactone (PCL): a potential scaffold for tissue engineering. *ASME J Biomech Eng*. 2008;130:011006–011006-13.
- [9] Bode M, Mueller M, Zernetsch H, Glasmacher B. Electrospun vascular grafts with anti-kinking properties. 49. BMT 2015 Annual Conference, Deutsche Gesellschaft für Biomedizintechnik, September 16.–18., Luebeck, Germany; 2015.
- [10] Broedling, William E. Flexible tubing. US 2321064 A. 1943.