

Textile carbon reinforcement structures with integrated optical fibre sensors designed for SHM applications

L.S.M. Alwis^a, K. Bremer^{*b}, F. Weigand^c, M. Kuhne^d, R. Helbig^c, B. Roth^b

^aSchool of Engineering and the Built Environment, Edinburgh Napier University, United Kingdom

^bHannover Centre for Optical Technologies (HOT), Leibniz University Hannover, Germany

^cSaxon Textile Research Institute (STFI), Chemnitz, Germany

^dMaterialforschungs- und prüfanstalt (MFPA), Weimar, Germany

ABSTRACT

An optical fibre-based strain sensor embroidered to a functionalised carbon structure (FCS) that can be used for structural health monitoring (SHM) is introduced. The aim of the design is not only to monitor strain, but also to act as a structural strengthening mechanism in the target application. The integration of optical fibres on the FCS is achieved by “interweaving” the two elements on a polymer textile substrate in a grid formation using a specialised fabrication process. The thus obtained sensor was then characterised using a fibre optic Mach-Zehnder (MZ) interferometric setup where a variation in the fibre length, i.e. resulting from strain, would induce a variation in the interference pattern. To do so, two different functionalised skein samples (incorporating optical fibres) were subjected to varying elongation using a tensile testing machine by carefully incrementing the applied force. A good correlation between the applied force and measured length change was observed, showing the value of the dual-achievement of the proposed optical fibre-based mechanism in obtaining strain measurement while being utilised as a strengthening agent.

Keywords: Carbon reinforcement, optical fibre sensor, functionalized carbon structures, SHM

1. INTRODUCTION

With the current trend in engineering and physical sciences towards the “smart city” concept, the implementation of sensor systems to monitor various aspects of a city, including that of the physical conditions of its civil structures is of vital importance. Structural health monitoring (SHM) has always been an attractive area of study within the sensors community and the recent advances in the uptake of fibre optic sensors (FOS) for the said purpose has seen a wide range of research into mechanisms in which sensors can be “embedded” into structures to provide real-time data [1]. The data thus obtained can then be used to predict potential structural failure, so that appropriate maintenance can be scheduled to address the economic benefits and ethical need for safe and sustainable infrastructures. This also goes hand in hand with the need to ensure that appropriate strengthening mechanisms of such structures are in place – the most recent advance being the utilisation of carbon fibre reinforcement polymer (CFRP) to strengthen concrete structures [2].

One of the most demanding applications of SHM is the monitoring of strain in concrete structures. The usual method of utilising FOS for the purpose is to “glue”, using for example epoxy, a network of sensors to the structure in question and monitor any variation in applied strain using interferometric techniques [2]. This technique, therefore, relies on the glue, that is used, being able to fully transfer the strain to the sensing element. Using this method, not only will the installation of the sensors be tedious, having to manually attach the sensors covering the interested area, but also, there is a likelihood of breaking the sensing elements while doing so, since most of these systems are fragile, grating-based sensors.

Recent developments in utilizing carbon reinforcement structures within SHM for sensing purposes is somehow limited to using the electrical properties of the carbon structure [3,4]. FOS possess a number of advantages over the conventional electrical sensors, most importantly being electrically passive (and hence safer to use) and therefore immune to electromagnetic interference. In addition, optical systems can handle a wider bandwidth of data which can be an added advantage to sensors systems involving the interrogation of vast amount of sensing elements such as required by SHM application, which is the case, for instance, for the SHM of sewerage tunnels [5,6].

* Kort.Bremer@hot.uni-hannover.de; +49 511 762 17905; www.hot.uni-hannover.de

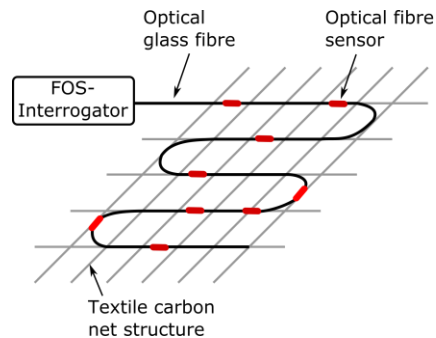

Figure 1. Schematic of the FCS with optical fibre sensors designed for the SHM applications

In light of the discussion above, the work presented here attempts to develop tailored FCS with integrated optical fibre sensors using a novel technique involving the embroidery of optical fibres and textile carbon filaments in a net-based structure. A schematic of the FCS with integrated optical fibre sensors designed for SHM applications is shown in Fig. 1. The proposed mechanism acts as both the reinforcement as well as the SHM mechanism, thereby saving a considerable amount of time and money. Furthermore, no glue is involved in the process and the strain would be directly transferred to the sensing element itself, ensuring more accuracy of the data obtained.

2. CARBON REINFORCEMENT STRUCTURES

An appropriate embroidery technology was developed at the Saxon Textile Research Institute (STFI), Chemnitz, Germany to manufacture the functionalized carbon structure (FCS). The developed embroidering technique allows the simultaneous processing of carbon fibres and optical fibre sensors to realise grid based functionalised carbon elements. Depending on the application, tailored carbon structures can be manufactured, i.e. several layers of carbon filaments with up to 50k filament fibres (corresponding to 3.200 tex), as well as very different grid structures. The modified embroidery machine for the fabrication of tailored carbon structures with integrated fibre optic sensors is shown in Fig. 2a and 2b.



Figure 2. Modified embroidery machine at the STFI that consists on an embroidery needle (a) and auto-tracking of the optical fibre (b) to simultaneously process carbon and optical glass fibres on a PVA nonwoven substrate (c).

In order to fabricate tailored textile based carbon reinforcement structures with integrated optical fibres first the optical glass fibre (Corning SMF28E XB) and the carbon fibres were embroidered on a polyvinyl alcohol (PVA) nonwoven substrate. To obtain tailored grid based carbon structures several layers of carbon fibres were embroidered subsequently on the PVA nonwoven substrate. After the embroidering fabrication process was finished, the nonwoven substrate was removed by dissolving the PVA in hot water (approx. 50 °C). A fabricated textile based carbon grid reinforcement with an integrated optical fibre on a PVA nonwoven substrate is shown in Fig. 2c.

3. EVALUATING FIBER OPTIC SENSOR PERFORMANCE

In terms of applying the integrated optical fibre for SHM of carbon reinforced elements, the characterisation of the sensor performance is important, including the evaluation of force transfer from the carbon structure to the optical fibre as well as the hysteresis and drift of the sensor. In order to do so, an initial proof of principle experiment on the performance of the integrated optical fibre sensor was conducted using a fibre optic Mach-Zehnder (MZ)-interferometer.

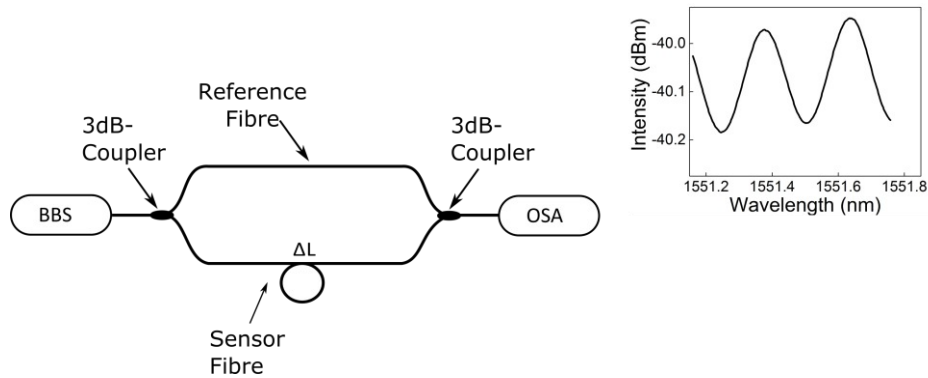

Figure 3. Developed fibre optical MZ-interferometer to evaluate and characterise the force transfer between the carbon reinforcement structure and optical fibre.

The MZ-interferometer consists of a broadband light source (BBS, Opto-Link C-Band ASE), two 3dB couplers, a Single-Mode (SM) fibre optic reference and sensor arm as well as an optical spectrum analyser (OSA, ANDO AQ6317B), as shown in Fig. 3. A length change ΔL of the sensor arm causes a phase difference $\Delta\phi$ between the light of wavelength λ travelling in both fibre arms and hence, a change of the interference pattern.

In the initial proof of principle study, the evaluation is based on a skein of a 30 cm long 400 tex carbon filament with an integrated optical glass fibre (Corning SMF28E XB). The functionalised carbon skein has been embroidered first on the PVA nonwoven substrate and then cut into 30 cm long samples after the PVA was dissolved. The functionalised skein embroidered on the PVA nonwoven substrate and the obtained 30 cm long samples are shown in Fig. 4a and 4b. Following this the integrated optical fibre was spliced to the developed MZ-interferometer and the sensor performance was characterised using a tensile testing machine (MFC T3000), as illustrated in Fig. 4c. In order to measure the force transfer between the textile carbon structure and optical fibre, only the carbon structure was mounted to the tensile testing machine.

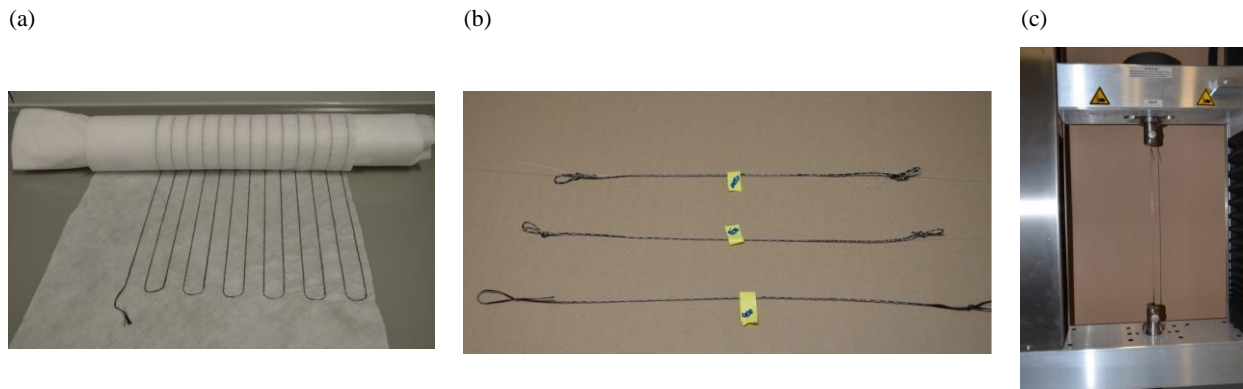

Figure 4. Functionalised carbon skein embroidered on the PVA nonwoven substrate (a) and the obtained 30 cm long samples after the PVA was dissolved. After fabrication the elongation transfer of the functionalised carbon skein was evaluated using the tensile testing machine MFC T3000.

The measured sensor performance of two different functionalised skein samples are shown in Fig. 5a and 5b. Both samples show a good correlation between the applied force and measured length change ΔL . For each sample, three subsequent measurements were performed. As illustrated in Fig. 5a and 5b, a relatively small hysteresis and drift were obtained for both samples. Based on the successful proof of principle study and the obtained fibre optic sensor performance, Fibre Bragg Gratings (FBGs) are currently being integrated into 2D textile carbon structures and are characterised.

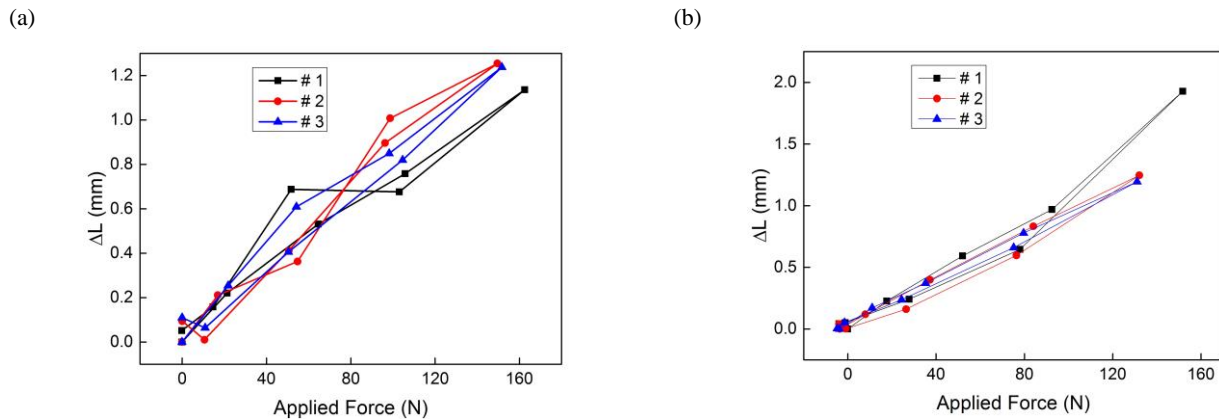

Figure 5. Response of two different 30 cm long functionalised carbon skein samples. The fibre optic MZ-interferometers of both samples show a good correlation between applied force and measured elongation ΔL with a relative small hysteresis and drift.

4. SUMMARY AND OUTLOOK

A functionalised carbon structure (FCS) that can be used for structural health monitoring (SHM) is introduced and evaluated. The FCS is based on textile carbon structures with integrated optical fibres or optical fibre sensors, respectively, that have been fabricated using a modified embroidery machine at the STFI in Chemnitz, Germany. This machine allows the cost-efficient fabrication of tailored FCS. In a proof of principle study the sensor performance of textile carbon skeins with an integrated optical fibre has been evaluated using a fibre optic MZ-interferometer. A good correlation has been achieved between applied forces and measured length changes. Based on the successful proof of principle study currently FBGs are integrated into 2D textile carbon structures and the sensor performance is characterised. The aim of the developed 2D textile carbon structures is not only for SHM, but also to be utilised as structural strengthening elements in the target application.

ACKNOWLEDGMENT

The authors acknowledge support of the Bundesministerium fuer Bildung und Forschung (BMBF) within Grant Number 03ZZ0345.

REFERENCES

- [1] Lopez-Higuera, J. M., Cobo, L. R., Incera, A. Q. and Cobo, A., "Fiber Optic Sensors in Structural Health Monitoring," *Journal of Lightwave Technology* (2011) Vol. 29, no. 4, pp. 587-608
- [2] Kerrouche, A., Boyle, W. J. O., Gebremichael, Y., Sun, T., Grattan, K. T. V., Täljsten, B., Bennitz, A., "Field tests of fibre Bragg grating sensors incorporated into CFRP for railway bridge strengthening condition monitoring", *Sensors and Actuators A: Physical*, Vol. 148, Issue 1, 4 November 2008, pp. 68-74
- [3] Goldfeld, Y., Rabinovitch, O., Fishbain, B., Quadflieg, T., and Gries, T., "Sensory carbon fiber based textile-reinforced concrete for smart structures", *Journal of Intelligent Material Systems and Structures* (2016) Vol. 27(4) pp. 469–489
- [4] Azhari, F., Banthia, N., "Cement-based sensors with carbon fibers and carbon nanotubes for piezoresistive sensing", *Cement and Concrete Composites* (2012) Vol. 34, 7, pp. 866-873
- [5] Bremer, K., Meinhardt-Wollweber, M., Thiel, T., Werner, G., Sun, T., Grattan, K. T. V., Roth, B., "Sewerage tunnel leakage detection using a fibre optic moisture-detecting sensor system", *Sensors and Actuators A: Physical* (2014) Vol. 220, 1, pp. 62-68
- [6] Alwis, L. S. M., Bustamante, H., Bremer, K., Roth, B., Sun, T., and Grattan, K. T. V., "Evaluation of the durability and performance of FBG-based sensors for monitoring moisture in an aggressive gaseous waste sewer environment", *Journal of Lightwave Technology* (2016), accepted for publication