

5<sup>th</sup> Conference on Production Systems and Logistics

# Application Of The Dynamic Tolerancing Approach To The Assembly Of Fuel Cell Stacks

Andreas Aichele<sup>1</sup>, Oliver Mannuß<sup>1</sup>, Alexander Sauer<sup>1,2</sup><sup>1</sup>Fraunhofer Institute for Manufacturing Engineering and Automation IPA, Stuttgart, Germany<sup>2</sup>Institute for Energy Efficiency in Production, University of Stuttgart, Stuttgart, Germany

## Abstract

The proton exchange membrane fuel cell (PEM-FC) makes it possible to provide electrical energy for a wide range of applications without polluting emissions as a by-product. However, various challenges need to be overcome before widespread use of this technology is possible. In addition to optimizing its performance and lifetime, a key challenge is to reduce production costs. Production processes significantly affect these three objectives. Tighter manufacturing tolerances on the main components, membrane exchange assembly and bipolar plate, for example, can improve the functions above. However, manufacturing to tighter tolerances usually leads to higher production costs. To resolve the contradiction between ‘tight tolerances’ and ‘low costs’, the principle of dynamic tolerancing was developed. So far, this principle has only been implemented for a shaft-hub connection. The approach presented here applies the principle to the assembly process of a stack for a PEM-FC and shows how the channel offset within a stack can be reduced without increasing the requirements for individual part tolerances.

## Keywords

Manufacturing technology; Assembly process; Cost reduction; Manufacturing tolerances; Stack assembly

## 1. Introduction

Fuel cells are becoming increasingly important as a source of energy. They convert chemical energy, provided in the form of fuel and an oxidant, into electrical energy. The fuel cell technology discussed in this paper is the polymer electrolyte membrane (PEM) fuel cell, which runs on hydrogen. It is the most common type. Compared to other fuel cells, the PEM fuel cell offers high (electrical) efficiency, low reaction temperatures, good quick-start capability, availability and handling of the fuel, and a high level of technological maturity [1].

### 1.1 Research issue

An essential criterion for the suitability of fuel cells for mass production, besides available infrastructure [2] and acceptance [3], is cost. It includes not only fuel costs but also the costs of producing the fuel cell. The manufacturing costs of fuel cells are currently higher than those of combustion engines of the same size. The largest share of manufacturing costs is attributed to the assembly of the fuel cell stacks, in particular for composing the bipolar plates (BPP) and membrane exchange assemblies (MEA) [4]. As some of this work still needs to be done manually, it represents a quality- and time-critical bottleneck in production [5]. The long-term goal is to further develop the production processes to allow for automatic mass production of the fuel cell and thus reduce production costs [6] and improve quality. A major influence on the quality of the fuel cell stack is geometry [2]. For constant and consistent functionality, the geometries must be

manufactured reproducibly within narrow tolerance limits. This can be achieved by very tight tolerances on the individual components and by high accuracy of the systems involved in the process. Both measures lead to higher manufacturing costs, which contradicts the goal of reducing production costs.

### 1.2 Objectives and tasks

Lorenzoni was able to resolve the contradiction of high quality vs. larger tolerances with his approach of dynamic tolerancing using a shaft-hub connection (Lorenzoni et al., 2019). Since a fuel cell stack is different from a shaft-hub connection, this paper aims to examine a possible application of dynamic tolerancing and to develop it further, if possible. Therefore, the paper addresses the following issues: Section 2 of the paper presents the necessary fundamentals. These are, in overview, the PEM-FC, the fuel cell stack including the manufacturing process, the geometric quantities relevant to quality, and Lorenzoni's dynamic tolerancing approach. Section 3 presents the developed approach. Section 4 gives a short summary and an outlook on further objectives for research on this topic.

## 2. State of the Art

The following gives an overview of the functionality and structure of a PEM-FC. It explains the stack and points out where applying dynamic tolerancing offers potential. Then, the most important geometric parameters influencing the characteristics of a PEM-FC are mentioned, and the approach of dynamic tolerancing is presented.

### 2.1 PEM-FC

As mentioned above, PEM-FC converts the chemical energy of hydrogen into electrical energy by adding an oxidizing agent. The essential components are two electrodes separated by two gas diffusion layers, two catalysts, and a semi-permeable membrane. The two electrodes, anode and cathode, are bipolar plates in the PEM-FC. On the anode side, hydrogen oxidizes to cations. On the cathode side, oxygen reduces to anions as an oxidant and can react directly with the hydrogen ions diffused through the membrane to form water (see Figure 1, left side). The voltage generated in this process is insufficient for most applications. Therefore, several cells are arranged in a stack and connected in series [3]. The bipolar plates act on one side as an anode for a single fuel cell and on the other side as a cathode for the next single cell of the stack. In addition, the gas diffusion and the catalyst layers are usually applied to the MEA. This structure is complemented by a current collector and an end plate at each end of the stack (see Figure 1, right side) [4].

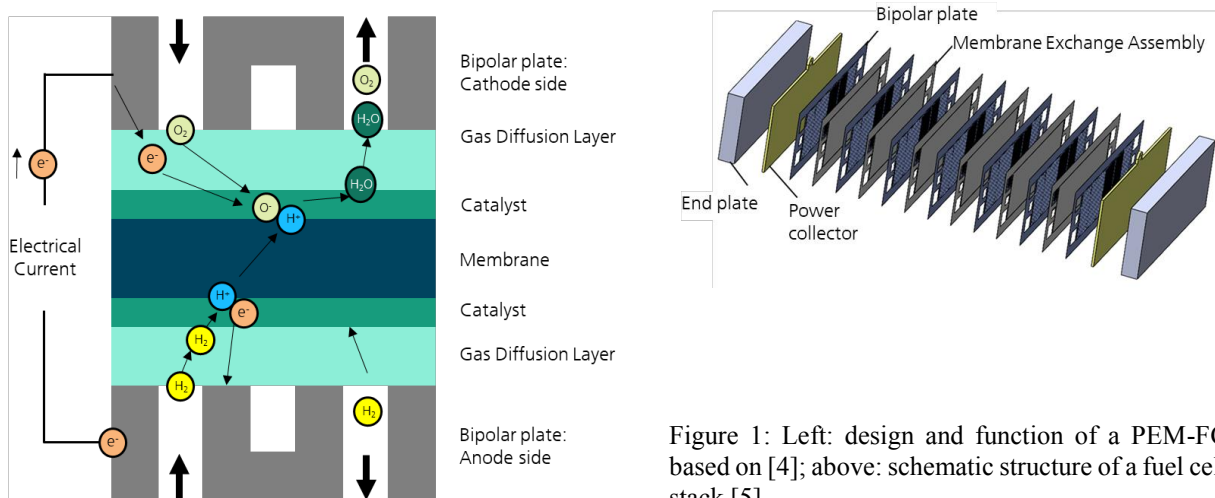

Figure 1: Left: design and function of a PEM-FC based on [4]; above: schematic structure of a fuel cell stack [5]

The stack assembly starts with pre-assembling the lower-end plate and the lower current collector. Then, the MEAs and BPPs are alternately placed on the stack. After depositing the required number of MEAs and BPPs, the upper current collector and the upper-end plate are placed next. Guide elements are used to ensure the exact alignment of the individual components of the stack (see Figure 2). [9]

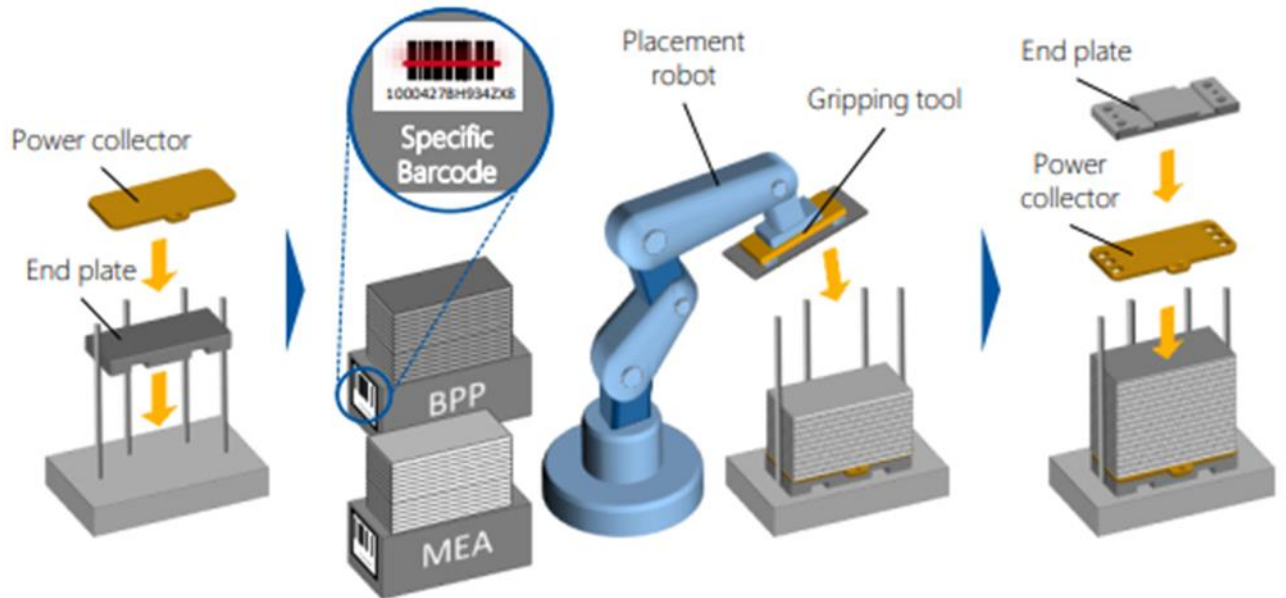

Figure 2: Illustration of the stacking process [9]

## 2.2 How geometrical sizes of the fuel cell stack and its components affect the target sizes of the PEM fuel cell

A literature search prior to this paper identified a number of important geometric variables for fuel cell performance [2]. Power and lifetime of a fuel cell, for example, were assumed as relevant performance criteria. ‘Flatness of the stack’, ‘different channel depths’, ‘channel offset’, and ‘channel cross-section’ were identified as influencing geometric variables [10,7,6,8,9]. The focus of this paper will be on the ‘channel offset’: In a stack, opposite BPPs are arranged mirroring each other. The aim is to achieve an exact match of the opposing flow fields so that the individual channels of the two flow fields coincide. If they do not coincide, this is referred to as a channel offset (see Figure 3). Aichele shows that this misalignment affects various functions of a PEM-FC and reduces the performance and lifetime of a PEM-FC [2]. The misalignment is production-related and can have the following causes:

- Variations in the spacing of the channels (absolute and with respect to parallelism) of the BPP during primary forming and welding of the plates [11]
- Varied position of the flow field to the reference points of the stack, depending on how the individual BPP is cut from the coil [12]
- Varied stacking positions in assembly due to inaccuracies of the robots and fixtures used [13]

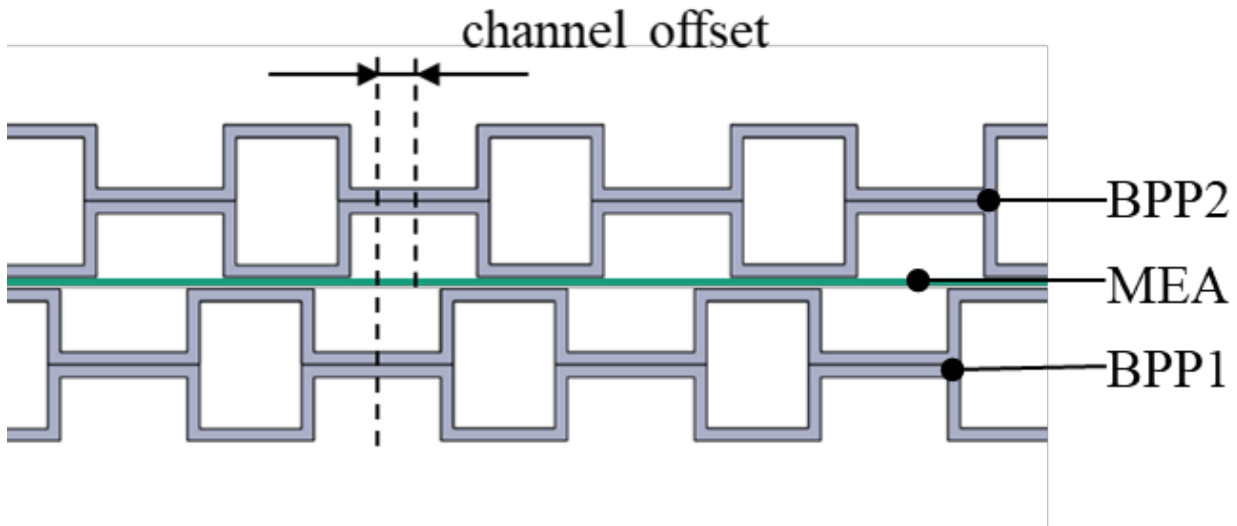

Figure 3: Schematic representation of two superimposed BPPs with channel offset based on [14]

### 2.3 Dynamic Tolerancing

The dynamic tolerancing methodology involves manufacturing two components of a fit function in sequence and logistically combining them in an assembly. In the first step, the first component of the assembly is manufactured. In the next step, the geometric size required for the fit function is measured and documented. The target value of the geometric size of the second component relevant to the fit function is calculated based on the actual value of the first component. The second component is then manufactured to these specifications (see Figure 4). The matched components are then assembled. The advantage of this method is that it eliminates the need to divide the tolerance field available for manufacturing between two components. Instead, it can be used either for manufacturing processes with lower tolerance requirements, thus saving costs. Or, it can be used to achieve higher accuracy and thus higher quality of the fit function for the same manufacturing cost. [15,16]

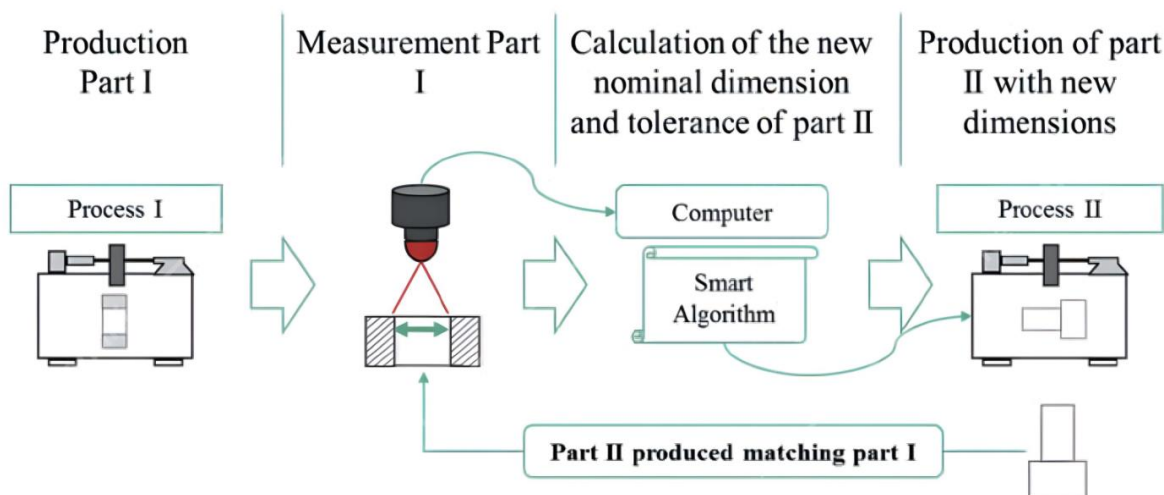

Figure 4: Basic approach of dynamic tolerancing [16]

### 3. Approach

A straightforward application of the dynamic tolerance approach described in Section 2.3 to channel misalignment in a fuel cell stack is not practical. In the case of hydroformed BPP, it is not possible to adjust the channels without significantly increasing the cost. Therefore, the dynamic tolerance approach must be applied in a different way. The first part of this chapter develops a basic scheme for doing this. The second section provides further details, including an example calculation. Section 3 integrates the concept into the overall stack assembly process.

#### 3.1 Transfer of the basic idea

Although in a different manner, the basic idea of dynamic tolerancing can also be applied to stack assembly. Dynamic tolerancing consists of three building blocks: Information, criteria, and options. Information represents the actual value of the first component. Criteria is the fitting function to be fulfilled. Together, information and criteria are used to derive the options, i.e., the target dimension, including the tolerances for the second component that still needs to be produced.

To apply this concept to the stacking process, we also need information, criteria, and options but in a different sequence: Information indicates the actual values of the geometric quantities of the BPP to be stacked. Instead of criteria, options come first, implying alternative stacking options. With actual values and alternative stacking options, it is possible now to check how the criterion can best be fulfilled for a BPP to be joined. To create alternative stacking options, several stacks can be stacked in parallel in the process. On the other hand, a point-symmetrical design enables an additional stacking option rotated by 180°. Assuming that two stacks are stacked in parallel and a point-symmetrical design is present, four stacking options are available (see Figure 5).

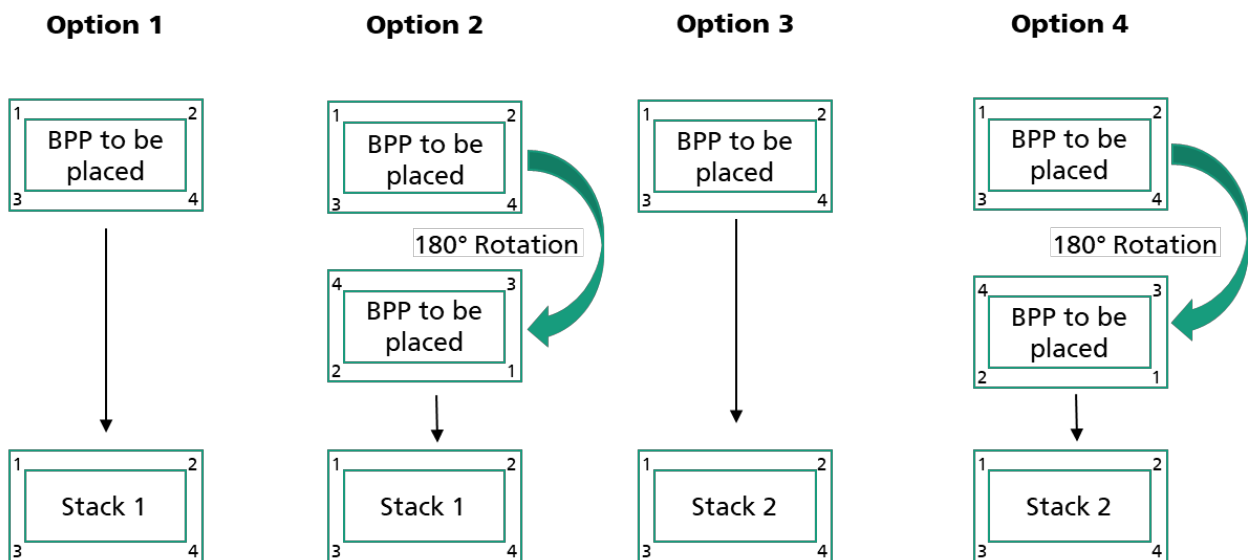

Figure 5: Placement options for the next BPP to be placed. The numbers in the corners indicate the orientation of the respective BPP.

### 3.2 Marginal conditions and sample calculation

For the further detailing of the approach the following marginal conditions have to be considered:

1. With regard to the causes of channel misalignment to be considered (see section 2.2):
  - Due to the tool-bound process of hydroforming in the production of the BPP, the variances in the distances between the channels (absolute and with regard to parallelism) are minimal and thus negligible [17].
  - The channel offset caused by inaccuracies of the robots and fixtures used, only arise during assembly. The approach of dynamic tolerance uses dimensions that arise before assembly.

It follows that only the varying position of the flow field in relation to the reference points of the stack can be considered in the dynamic tolerance approach.
2. A relevant deviation of the flow field occurs only in the x-direction, since this can be caused by the cutting process. No offset is to be expected in the y-direction, since this is only influenced during hydroforming and, as mentioned, this is a dimensionally stable process.
3. The joining edges for the stack are two outer edges: one each in x- and y-direction (see Figure 6).
4. From 2. + 3. follows: The possible deviation from the position of the flow fields can be represented by the dimensions dx1 and dx2 between the joining edge and the flow field (see Figure 6).
5. The nominal distance dx is 50.00 mm and its tolerance is  $\pm 0.125$  mm (typically for hydroforming) [11].
6. The actual size of the dimensions is normally distributed.
7. The BPP is point-symmetric.
8. two stacks are stacked in parallel with one robot.

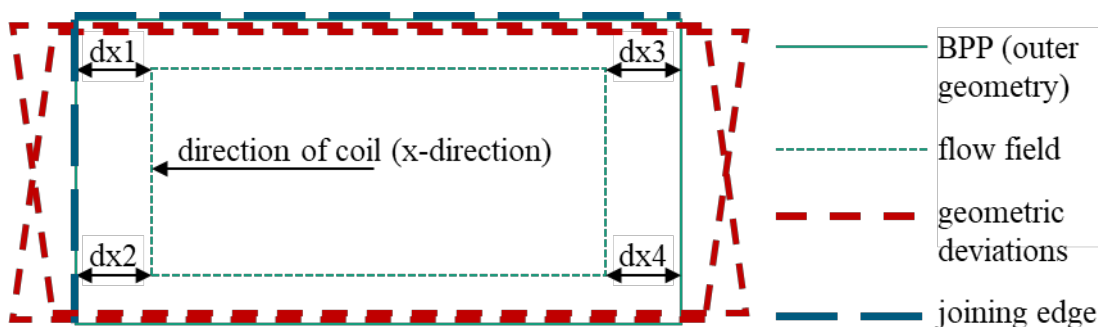

Figure 6: Schematic representation of the flow field on a BPP

To obtain a result concerning the channel offset from the deviations of the flow field, it is necessary to determine the maximum value of dx1 and dx2 of the BPP on the stack ('BPP Stack') and the BPP to be joined ('BPP 2'). Due to the marginal conditions shown above, the maximum value is the relevant value for offset of the flow fields and accordingly for the channel offset in the stack. The maximum values of the BPP to be joined and the BPP on the stack must then be subtracted from each other (see formula 1). If a point-symmetric BPP additionally allows for a 180° rotated placement, dx3 and dx4 of BPP 2 must be considered instead of dx1 and dx2. Then, the resulting channel offset is calculated according to formula 2. If the desired overlap of the flow field is as high as possible, i.e., there is a very low channel offset, the difference is as close to 0 as possible. To create an optimal channel offset with several delivery options, the minimum difference must be selected (see Formula 3).

$$CO_{BPP2-BPP\ Stack} = \max(dx1_{BPP\ 2}; dx2_{BPP\ 2}) - \max(dx1_{BPP\ Stack}; dx2_{BPP\ Stack}) \quad (1)$$

$$CO_{BPP2-BPP\ Stack} = \max(dx3_{BPP\ 2}; dx4_{BPP\ 2}) - \max(dx1_{BPP\ Stack}; dx2_{BPP\ Stack}) \quad (2)$$

$$\min(|CO_{Option1}|; |CO_{Option2}|; |CO_{Option3}|; \dots) \quad (3)$$

An example calculation illustrates the approach presented below. According to Figure 6, there are four stacking options: Positioning on stacks 1 and 2, each at 0° and 180°. BPP 1 is on stack 1, and BPP 2 is on stack 2 in the 0° position. BPP 3 is now to be joined with as little channel offset as possible. The necessary dimensions are found in Table 1. These are used for calculating the channel offset for each stacking option (see Table 2). The best option for this example is to select tray option 4. BPP 3 should therefore be added to stack 2 and rotated by 180°. It allows for achieving a flow field offset of 0.01 mm. This is a 66% improvement compared to stacking options 2 and 3 and an 80% improvement on stacking option 1.

Table 1: Relevant values of the BPPs

BPP	d <sub>x1</sub> [mm]	d <sub>x2</sub> [mm]	d <sub>x3</sub> [mm]	d <sub>x4</sub> [mm]
1	50,05	50,02	49,97	49,95
2	50,02	50,03	50,01	49,97
3	50,00	49,98	50,02	49,95

Table 2: Example calculation for an optimized channel offset

Stacking option	description	$\max\left(\begin{matrix} dx1_{BPP\ Stack}; \\ dx2_{BPP\ Stack} \end{matrix}\right)$	$\max\left(\begin{matrix} dx1_{BPP\ 3}; \\ dx2_{BPP\ 3} \end{matrix}\right)$	$\max\left(\begin{matrix} dx3_{BPP\ 3}; \\ dx4_{BPP\ 3} \end{matrix}\right)$	CO
1	BPP 1; 0° BPP3	50,05	50,00	not relevant	0,05
2	BPP 1; 180° BPP3	50,05	not relevant	50,02	0,03
3	BPP 2; 0° BPP3	50,03	50,00	not relevant	0,03
4	BPP 2; 180° BPP3	50,03	not relevant	50,02	<b><u>0,01</u></b>

### 3.3 Integration into the stack assembly

The basic applicability of dynamic tolerancing has been demonstrated in sections 3.1 and 3.2. However, the successful integration of a stack into the assembly process with a robot requires further steps. For this purpose, the stack assembly process presented in section 2.1 is applied. For stacks 1 and 2, pre-assembly of the bottom end plate and the bottom current collector is performed first, followed by the placement of one BPP per stack. This is where the dynamic tolerance approach from section 3.2 comes in. The relevant dimensions of the already placed BPP are recorded and stored. The next BPP to be placed is measured and the measurement data is stored. The recorded data can now be used to calculate and realize the optimal placement position according to section 3.2. Depending on the selected position, new measurements must be stored for Stack 1 or Stack 2 and an MEA must be placed on it. The process must be repeated until the required number of BPPs and MEAs are placed on a stack. Finally, the top current collector and top end plate are added to the stack, closed, and removed from the assembly area by the robot. The process begins again at the location of the ejected stack (see Figure 7).

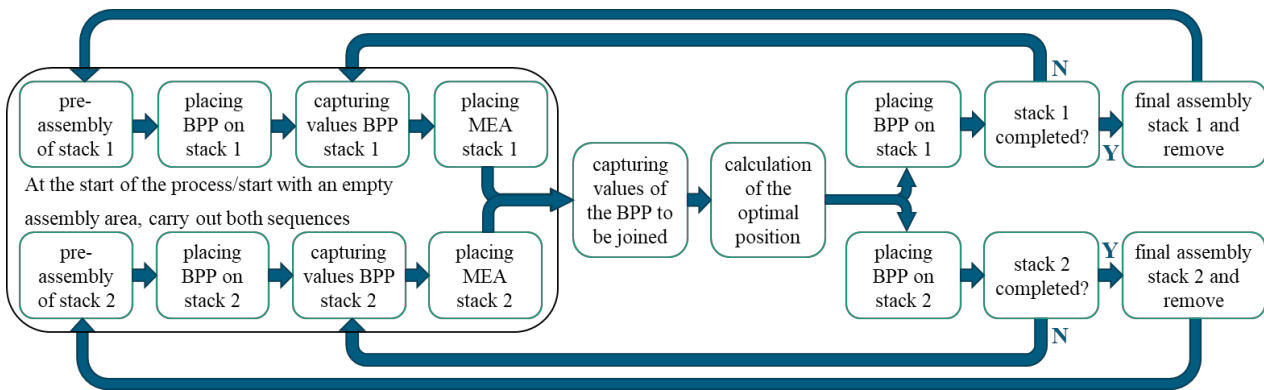

Figure 7: Sequence in a stack assembly with integration of the dynamic tolerancing approach

#### 4. Conclusion

The presented approach demonstrated that applying and implementing the dynamic tolerance approach for the channel offset in stack assembly is possible. The exemplary calculation for joining two BPPs significantly improved the channel offset. However, in order to improve not only the channel offset, but also the characteristics of a fuel cell, more research is needed. For example, the extent to which performance and lifetime are improved by reducing tolerances needs to be demonstrated. It is also important to note that the dynamic tolerance approach does not only improve the channel offset. Other geometric quantities are the geometric variables of channel depth, cross-section, and flatness (mentioned in section 2.2). The parallel application to several quantities may require the development of a meta-model. This would enable the assembly of the best possible stacks, taking into account the individual approaches.

#### Acknowledgements

This work is part of the project ‘Demonstrator-Pilotanlage für die Produktion von Brennstoffzellen’/ ‘H2FastCell’ and has received funding from the Ministry of Economics, Labour and Tourism of the State of Baden-Württemberg under the funding code BW1\_0114/07. The authors are responsible for the content of this publication. Corresponding author is Andreas Aichele.

#### References

- [1] Mekhilef, S., Saidur, R., Safari, A., 2012. Comparative study of different fuel cell technologies. *Renewable and Sustainable Energy Reviews* 16 (1), 981–989.
- [2] Aichele, A., 2023. Geometric parameters influencing the characteristics of a stack of a PEM-FC, in: *Annual World Conference of the Society for Industrial and Systems Engineering (12 : 2023 : Munich)*, Society for Industrial and Systems Engineering (Eds.), *Proceedings of the 12th Annual World Conference of the Society for Industrial and Systems Engineering*. 2023 SISE Munich. 09.-10.10.2023.
- [3] Kurzweil, P., 2013. *Brennstoffzellentechnik: Grundlagen, Komponenten, Systeme, Anwendungen, 2., überarbeitete und aktualisierte Auflage* ed. Springer Vieweg, Wiesbaden, 248 pp.
- [4] Schmidt, V.M., 2003. *Elektrochemische Verfahrenstechnik*. Wiley.
- [5] Beyer, U., Porstmann, S., Baum, C., Müller, C., 2022. Produktion der PEM-Systeme, Hochskalierung, Rollout-Konzept, in: Neugebauer, R. (Ed.), *Wasserstofftechnologien*. Springer Berlin Heidelberg, Berlin, Heidelberg, pp. 297–330.



- [6] Li, W.Z., Yang, W.W., Zhang, W.Y., Qu, Z.G., He, Y.L., 2019. Three-dimensional modeling of a PEMFC with serpentine flow field incorporating the impacts of electrode inhomogeneous compression deformation. *International Journal of Hydrogen Energy* 44 (39), 22194–22209.
- [7] Imscher, P., Qui, D., Janßen, H., Lehnert, W., Stolten, D., 2019. Impact of gas diffusion layer mechanics on PEM fuel cell performance. *International Journal of Hydrogen Energy* 44 (41), 23406–23415.
- [8] Taymaz, I., Benli, M., 2010. Numerical study of assembly pressure effect on the performance of proton exchange membrane fuel cell. *Energy* 35 (5), 2134–2140.
- [9] Zhang, L., Liu, Y., Song, H., Wang, S., Zhou, Y., Hu, S.J., 2006. Estimation of contact resistance in proton exchange membrane fuel cells. *Journal of Power Sources* 162 (2), 1165–1171.
- [10] Hoppe, E., Janßen, H., Müller, M., Lehnert, W., 2021. The impact of flow field plate misalignment on the gas diffusion layer intrusion and performance of a high-temperature polymer electrolyte fuel cell. *Journal of Power Sources* 501, 230036.
- [11] Bell, C., Corney, J., Zuelli, N., Savings, D., 2020. A state of the art review of hydroforming technology. *Int J Mater Form* 13 (5), 789–828.
- [12] Kampker, A., Ayvaz, P., Schön, H.C., Reims, P., Krieger, G., 2020. *Produktion von Brennstoffzellenkomponenten*, 1.th ed. VDMA Eigendruck, Aachen.
- [13] Liu, D., Peng, L., Lai, X., 2010. Effect of assembly error of bipolar plate on the contact pressure distribution and stress failure of membrane electrode assembly in proton exchange membrane fuel cell. *Journal of Power Sources* 195 (13), 4213–4221.
- [14] Qiu, D., Peng, L., Lai, X., Ni, M., Lehnert, W., 2019. Mechanical failure and mitigation strategies for the membrane in a proton exchange membrane fuel cell. *Renewable and Sustainable Energy Reviews* 113, 109289.
- [15] Lorenzoni, A., 2020. *Methodik zur dynamischen Tolerierung am Beispiel einer Welle-Nabe-Verbindung*. Dissertation, Stuttgart.
- [16] Lorenzoni, A., Tielemann, C., Sauer, A., 2019. Reducing manufacturing costs: the dynamic tolerance system. *Cogent Engineering* 6 (1).
- [17] Porstmann, S., Wannemacher, T., Drossel, W.-G., 2020. A comprehensive comparison of state-of-the-art manufacturing methods for fuel cell bipolar plates including anticipated future industry trends. *Journal of Manufacturing Processes* 60, 366–383.

## Biography



**Andreas Aichele** (\*1989) is a research associate in the Quality Department at the Fraunhofer Institute for Manufacturing Engineering and Automation IPA, Stuttgart. He works in the field of technical risk analysis and process optimization with a focus on quality issues. He is a facilitator for quality tools and Six Sigma Black Belt, both in research as well as in operational application.

**Oliver Mannuß** (\*1969) is group manager of Quality and Reliability Engineering. He has done more than 100 risk analyses in industrial projects in automotive, machinery, and medical/pharma branches. His research fields are machinery availability, and the process analysis of geometrical and processual influence factors on product characteristics.

**Alexander Sauer** (\*1976) is head of the Fraunhofer Institute for Manufacturing Engineering and Automation IPA, Stuttgart. Prof. Dr.-Ing. Alexander Sauer is also head of the Institute for Energy Efficiency in Production at the University of Stuttgart.