

Marx, Christian; Pastrana Pérez, Julio César; Hustedt, Michael; Barcikowski, Stephan; Haferkamp, Heinz and Rath, Thomas

# Investigations on the absorption and the application of laser radiation for weed control

Thermal weed control with flame-scarfing, hot water/superheated steam, and hot foam devices is limited regarding selective application. This is especially disadvantageous for weed control in crops, as the thermal damage has a spatial effect. Hence, an alternative tool is required; this might be the laser technology. During laser application, the laser parameters can be adjusted on-line to the recognized weed situation. Corresponding investigations are performed cooperatively at the Biosystems and Horticultural Engineering Section of the Leibniz University Hannover together with the Laser Zentrum Hannover.

## Keywords

Damage model, laser-based weed control

## Abstract

Landtechnik 67 (2012), no. 2, pp. 95–101, 13 figures, 12 references

■ Against the background of environmental protection non-chemical methods are increasingly used to control weeds. Thermal weed control plays a crucial role, but there are high-energy costs [1, 2] to consider. The efficiency of the method increases significantly on selective use, i. e. when the thermal energy is accurately targeted at a specific part of the weed. Only the growth centers (meristems) of the weed plants should be treated, as this has an effect on the entire weed and achieves the required result. The required high-resolution selectivity of heat treatment can only be achieved through the strategic use of focused energy, which can be provided by lasers.

Laser irradiation leads to absorption of energy in the plant tissue and usually to a conversion into heat, through which the meristem is destroyed. The critical point during the large-scale use of laser technology for weed control is the coupling of the laser light at the correct point of the weeds. Particularly important are: the laser wavelengths, radiation intensities, technically feasible targeting devices, as well as the weed species and their growth stages [3–8]. Laboratory experiments have shown that seedlings can be lethally damaged with at least 35 J [8, 9]. Under practical conditions the laser beam must also be positioned automatically in order to achieve high coupling efficiencies into the target tissue. A patent application [10] from the year 2003 brought no practical implementation. In

further studies, problems have occurred in targeting [11]. An efficient coupling of laser radiation is the basic prerequisite for successful weed control with laser technology, which previous attempts have shown. Here, the temperature effects of laser radiation on the leaf or the plant is of central importance. However, these effects are limited in practice due to unreliable hit accuracy.

The objectives of this study were therefore:

First, to examine the heat introduction of laser radiation in plant tissue for different lasers and second, to develop a prototype system for laser application (primary: goal setting system).

## Materials and methods

### Laser impact

To investigate the impact of radiation on weed tissue, experiments were performed on *Amaranthus retroflexus* (dicotyledonous). Different types of laser and laser parameters (see below) were used. The introduction of heat led to a rise in temperature at the points of impact and was recorded using thermography (FLIR-camera) (**Figure 1**).

To simulate the varieties of targeting precision, measurements were made to identify the impact of the laser. In **Figure 1** (left) this is labeled with “Spot 12”.

The absorption of laser radiation in plant tissue is dependent on the wavelength of the laser used. **Figure 2** shows the absorption spectrum of a leaf in a fresh and dry state. Due to the high water content of the leaf, the absorption of the H<sub>2</sub>O spectra is clear. Consequently, only lasers with a high degree of absorption in the plant tissue should be used for weed control.

Fig. 1

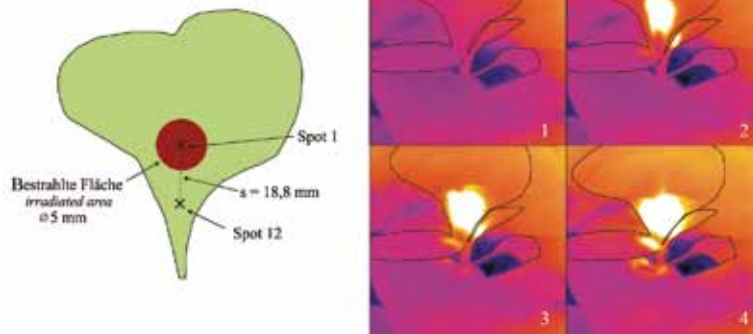

Irradiation tests and thermal images of leaves (*A. retroflexus*); left: 1 laser and 12 measure spots; right: during stationary laser irradiation with 11 W (1: before start, 2: after 5 s, 3: after 10 s, 4: after 15 s) (Drawing, photos: Ch. Marx)

Fig. 2

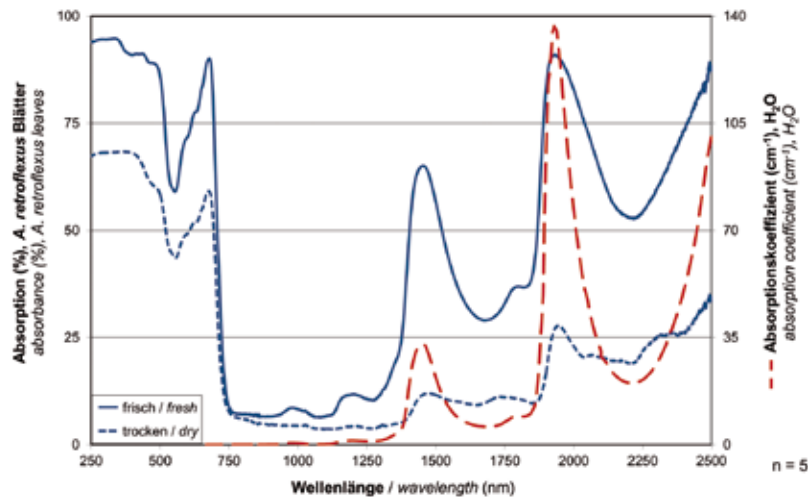

Absorption spectra of fresh and dried leaves (*A. retroflexus*) and the absorption coefficients of water

The study of heat introduction was performed using different types of laser:

1. No to weak laser: laser energy in quasi-cw operation (cw = continuous wave) applied permanently using a defocused beam on the surface of the leaf.
2. Strong laser: laser energy is applied in ultra-short pulses (ns-range) as a raw laser beam onto the surface of the leaf.
3. Meandering application of laser beam (wobble effect): laser energy applied in quasi-cw operation by a spirally guided movement with a focused laser beam on the target area.

The following systems were used:

- for 1) Diamond K-500 (Coherent Inc.), CO<sub>2</sub> laser ( $\lambda = 10\ 600\ \text{nm}$ )
- for 1) LDF 600-250 (Laserline GmbH), diode laser ( $\lambda = 940\ \text{nm}$ )
- for 2) SpitLight DPSS 250 (Innolas GmbH), solid-state laser ( $\lambda = 532\ \text{nm}$ ), 125 mJ per pulse
- for 3) 48-5 (Synrad Inc.), CO<sub>2</sub> laser ( $\lambda = 10\ 600\ \text{nm}$ )

**Figure 3** shows the setup of the experiment. The control consisted of a USB-switching system (U12 Labjack UBRE and ME) and operating software (ProfiLab Expert 4.0) (circuit shown in **Figure 4**). All of the experiments were repeated five times. The damage to the tissue was detected by scanning electron microscopy (FEI Quanta 400FE) and was evaluated visually.

Fig. 3

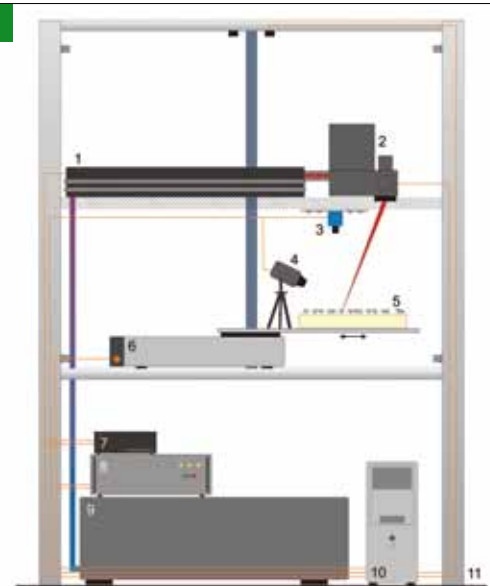

Test station (Drawing: Ch. Marx)

1: Laser system, 2: Galvanometer, 3: Camera with exposure, 4: IR camera, 5: Plant material, 6: Linear axis, 7-8: Power supplies, 9: Cooling-water system, 10: PC-based control, 11: Laser protection cabin

Fig. 4

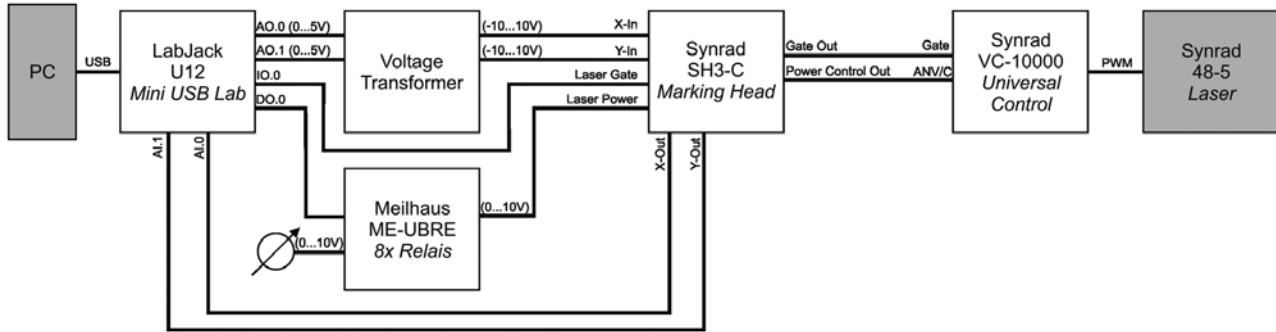

Schematic diagram for control of galvanometer-servo motors (Drawing: Ch. Marx)

### Development of a prototype for laser application

The test stand shown in **Figure 3** highlights the basis for the prototype of laser application. The laser was positioned by two combined servomotors (HSR-5990TG, Hitec Inc) instead of using a galvanometer scanner. A pilot laser (Laser Pointer SML650-01-D, Optlectra GmbH) in the visible wavelength range (650 nm) was used. The crop detection was performed using a stereo camera system (Microsoft LifeCam VX-3000, 800 x 448 pixels), 3-D triangulation and active shape modeling algorithms [12] for target positioning. The whole system was controlled by a servo motor controller (Mini Maestro 12, Polulu Corp., Maestro Control Center), which acted with the image processing via networked netbooks (Asus EeePC 1015PN). The illumination was carried out using 10 high-power LEDs (Luxeon Rebel, Phillips Lumileds).

To investigate the accuracy of the system, mock-ups were used in 1:1 scale. This enabled the generation of meristem elevation and positioning of the weeds. The development and validation of the prototype continued in the laboratory and was subsequently transferred to a greenhouse.

## Results

### Heat introduction by laser radiation

As a result of irradiation with the lasers used, energy couplings emerged in the weeds that could be divided into three impact categories: intact, lethal and growth-impaired.

**Figure 5** shows the thermodynamic processes involved exemplarily.

It is clear that optimal laser treatment must result in growth inhibition and wilting, and may not stop at the level of growth disturbance. Likewise energy couplings should be avoided, where the tissue is completely destroyed and a significant amount of laser energy just transmits through. From a certain period of irradiation, no further increase of energy input is realized, because there are perforations and severe damage to the tissue. This effect is increased with increasing hit accuracy of the application system (see various spot lines in **Figure 6**).

At a constant irradiation period, the injected amount of heat primarily depends on the laser energy and the accuracy of the application system (**Figure 7**).

Based on the measurements carried out, the following guide values regarding the necessary increase in temperature could be derived by energy coupling: a lethal energy coupling occurred when the temperature increase was in small plants  $> 1.0 \text{ K ms}^{-1}$  at 1 mm radial distance from the target center spot. For large plants (4-leaf stage), the guide value was necessary to  $2.5 \text{ K ms}^{-1}$  at 2 mm radial distance.

The use of oscillating guided laser radiation (wobbling) could save energy by “scanning” the target area to be irradiated and the more efficient energy coupling. **Figure 8** illustrates this effect using the comparison of image 1 and 2 with the indicated degree of perforation. No improvement was achieved with the

Fig. 5

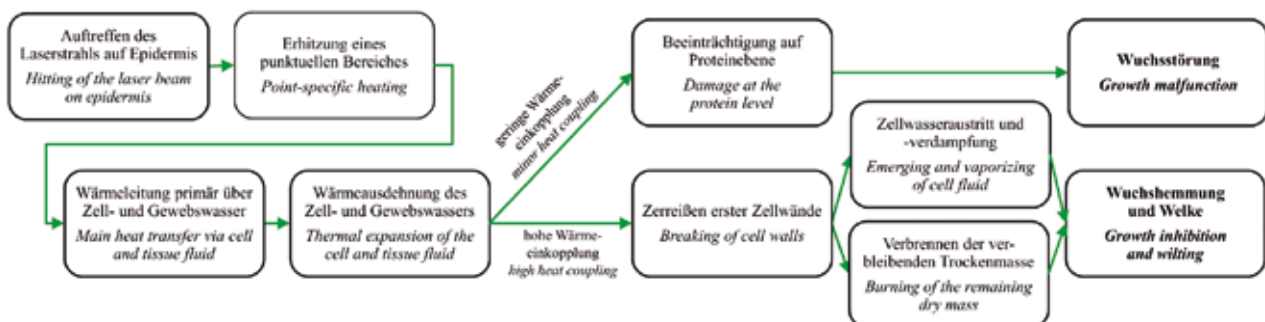

Causal chain of laser irradiation

Fig. 6

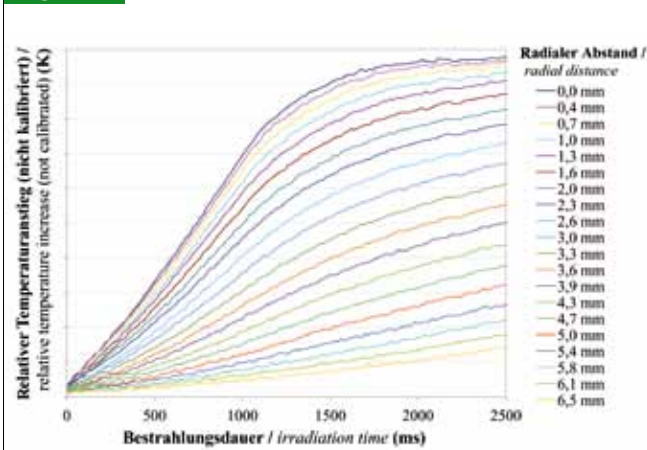

Presentation of thermal measurements with radial distance to the aim spot center during constant irradiation (CO<sub>2</sub>-laser, λ = 10 600 nm, 3.5 W)

Fig. 7

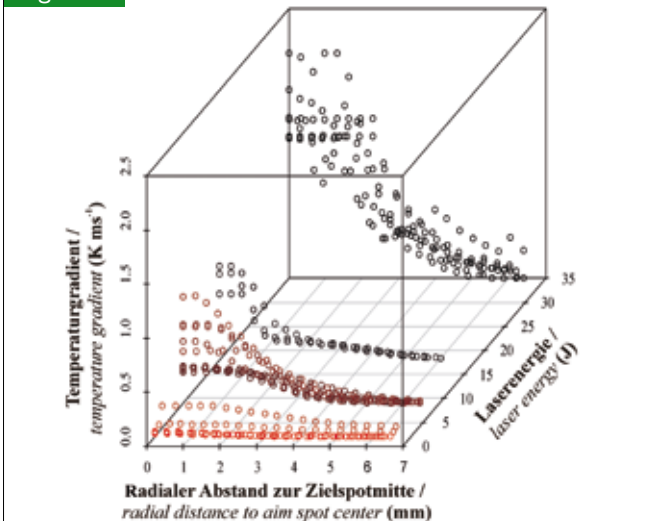

Influence of applied laser energy (Gauß-beam with ø 6 mm) on temperature gradient relative to the aim spot center

coupling results of ns-pulsed laser irradiation, which were more an explosive water evaporation and thus ruptured and caused perforation of the tissue (Figure 8, Image 3). Image 4 also shows the influence of the laser wavelength and the beam profile. Since the diode laser differs from a Gaussian profile and at the same time had decreased absorption, a comb-like beam profile and high beam energies only led to decentralized perforation.

At a constant laser spot size for a given wavelength, the quality of the laser application weed treatment is mainly dependent on the accuracy of the application system. The location of laser application is clear: In the monocotyledonous weeds the growth center is sheltered between the cotyledons, as these can be seen easily in dicotyledonous plants (the apical meristem). Therefore, laser treatment on monocotyledonous weeds is usually more problematic than the treatment of dicotyledonous species.

Fig. 8

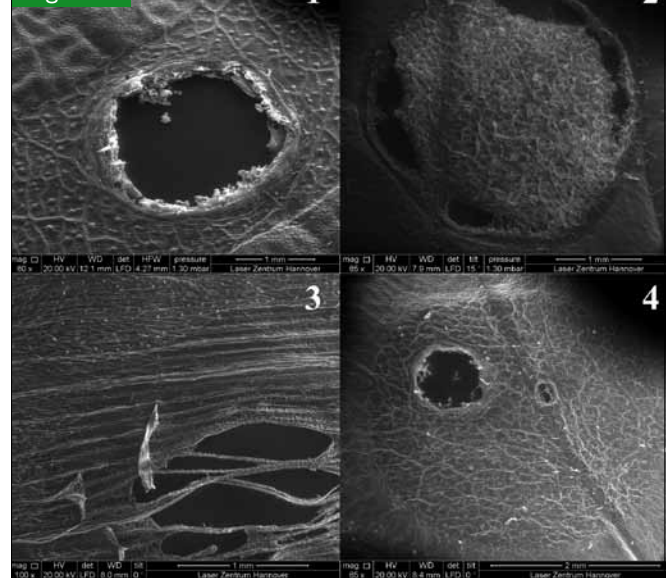

REM images of laser-irradiated leaves (Photos: Ch. Marx)  
 1: Diamond K-500, CO<sub>2</sub>-laser (λ = 10 600 nm), energy: 8.9 J, spot diameter: ø 3 mm  
 2: 48-5 (Synrad Inc.), CO<sub>2</sub>-laser (λ = 10 600 μm), energy: 7.1 J, entire spot diameter: ø 3 mm with ø 200 μm focused beam  
 3: SpitLight DPSS 250 (InnoLas GmbH), solid-state laser (λ = 532 nm), energy: 1 ns pulse with 125 mJ, spot diameter: ø 6 mm  
 4: LDF 600-250 (Laserline GmbH), diode laser (λ = 940 nm), energy: 70.8 J, spot diameter: ø 6 mm

Fig. 9

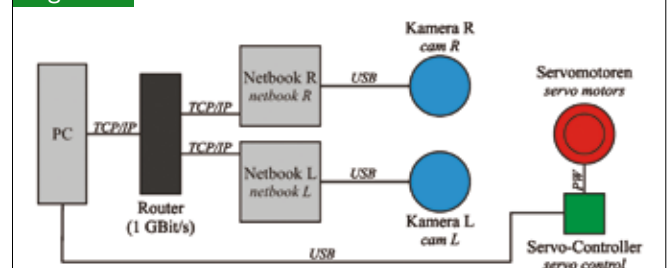

Linking of the system components

**Development of an application prototype**

The laser beams were directed by mirror systems at a certain angle to the target positions. Therefore independent of the weed species, the 3-D coordinates (i.e. the target positions including the height) have to be known and targetable.

The objective of the development of the application system was therefore a 3-D control of the laser through optical systems. The system was developed on the basis of the listed components in the materials and methods section within a TCP/IP-based network merge concept (Figure 9).

The stereo cameras with the LED exposure and the servo motors have been mounted 70 cm above the level of application. The axes of rotation of the servomotors cut in the center of the lens of the laser pointer. The stereo cameras had to be

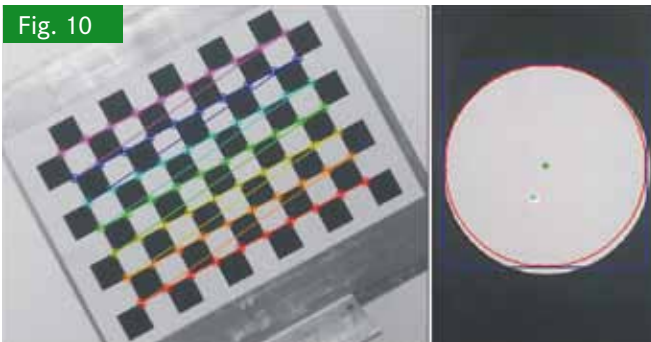

Fig. 10

Calibration of the stereo vision and laser positioning (Photos: Ch. Marx)

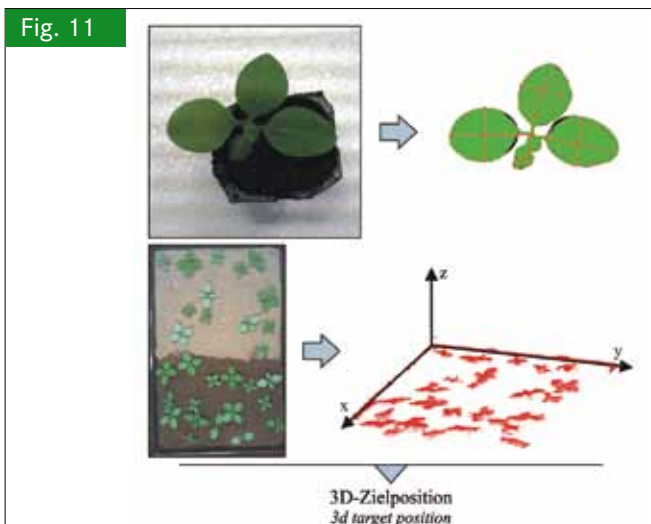

Fig. 11

Usage of active-shape-modelling (top) and stereo-vision-mapping (bottom) for determination of the target position (Photos: Ch. Marx)

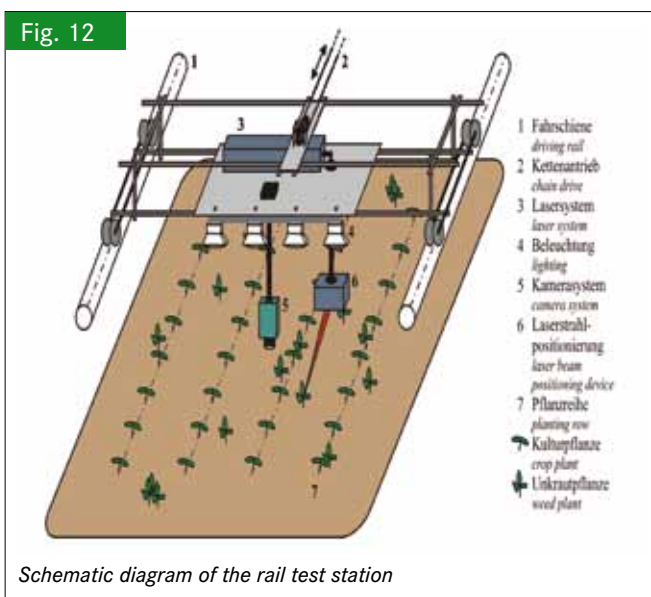

Fig. 12

Schematic diagram of the rail test station

mounted laterally and offset to provide space for the rotational movements of the servomotors.

Due to deviations from the nominal positions (e.g. unknown tilt angle, temperature dependence), the cameras were equalized with sample images and calibrated spherical (OpenCV).

The stereo images were combined algorithmically to derive 3-D information for height adjustment to the soil surface. The servo motor control is calibrated to the stereo camera system by a fixed set-point laser spot, which was detected by the cameras and converted into correction equations (Figure 10, right). For calibration, many desired positions were actuated and compared with the respective actual positions. Therefore, for the test system, a correction matrix (translation and rotation) was created for the reference to a global coordinate system.

The respective 2-D images of the left camera were analyzed with the ASM algorithms and the target position was calculated in the 2-D space. Using triangulation, the height profile image of the scenario was calculated at the same time (Figure 11), which was aligned with the target positions in the 2-D space. Results were the target positions of the weeds in the 3-D space, which were then actuated with the laser and checked for accuracy.

Through constructive improvement of the axis guide, integration of starting and stopping algorithms, as well as spherical and linear corrections, the laboratory system reached a laser application accuracy of  $<\pm 1$  mm. Thereby, different actuation routes were investigated with the spatially distributed application positions.

The laboratory system was transferred to an existing rail test bench in the greenhouse. Here, the movement of the laser system was carried out with a rail car on guide roles, which was moved by the chain drive of an AC induction motor (Figure 12).

To secure the laser and for a reproducible evaluation by image recognition software, the system was housed. The studies on the evaluation of the prototype system in the greenhouse were carried out in stop-and-go mode. This was controlled by means of frequency converter, Lab Jack U12 and Profilab Expert 4.0.

Similar to the laboratory system, the system was initially brought into a stable state by auto-calibrations.

Figure 13 illustrates the sequential evaluation with 20 freely placed weed plants, the result of 20 individual images were superimposed (left). Using automated detection, a beam positioning accuracy with a mean positional error of  $\pm 3.4$  mm was reached. The spatial variation is shown in the right part of Figure 13. It is seen that the accuracy was low at the edges. While limiting the application to the area of the image center, the mean deviation decreases to about 2 mm.

## Conclusions

The application energy necessary for lethal damage is largely dependent on the efficiency of energy coupling in the meristem and of the achievable accuracy of the laser application.

High efficiency of energy coupling can be achieved by the following factors:

- Wavelength in the middle infrared range
- Low power and long irradiation time
- Application of weak pulsed lasers or meander-like routes (wobble)

Abb. 13

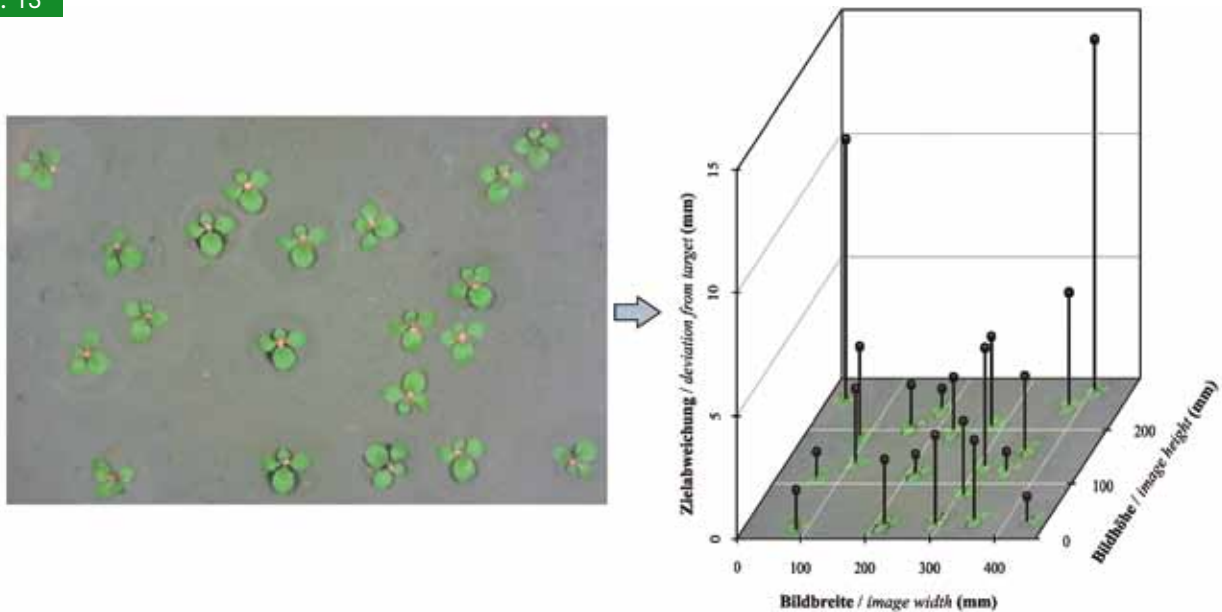

Test of the system with 20 positioned weed plants (image processing and positioning of the laser beam) (Photos: T. Rath)

- Laser spot is not larger than the target tissue (meristem)
- Very large overlap of the target spots and the viable laser spot during operation

In particular, factors two and four are most opposed to the current requirements of agricultural weed control (high output and the resulting dynamic conditions in the operation of the system). It should be noted that the irradiation time is a systemic factor that cannot be compensated by faster software / hardware. The irradiation time necessary for efficient energy coupling (e.g. 500 ms per plant) can be a problem at high weed density. However, weedy areas without crops can efficiently be cleaned by mechanical or thermal methods. Even a combination of different methods is conceivable.

Serious studies concerning the possible application speeds and maximum weed densities are currently conducted on the described test rig. Simulation results indicate that fast-moving farm machinery on larger weed densities require higher laser power, but cannot be injected adequately into the plant tissue. Slow moving field machines or autonomous field robots in stop-and-go operation could help.

### Literature

- [1] Astatkie, T.; Rifai M.N.; Havard P.; Adsett J.; Lacko-Bartosova, M.; Otepka, P. (2007): Effectiveness of hot water, infrared and open flame thermal units for controlling weeds. *Biol. Agric. Hortic.* 25(1), pp. 1-12
- [2] Raffaelli, M.; Fontanelli, M.; Frascioni, C.; Sorelli, F.; Ginanni, M.; Peruzzi, A. (2011): Physical weed control in processing tomatoes in Central Italy. *Renewable agriculture and food systems* 26(2), pp. 95-103
- [3] Bayramian, A.; Fay, P.K.; Dyer, W.E. (1992): Weed control using carbon dioxide lasers. *Proceedings of the Western Society of Weed Science*, vol. 45, 10-12 March 1992, Salt Lake City, USA, pp. 55-56
- [4] Hoki, M. (2000): Fundamental study of laser application for weed and pest control effect of laser emissions on rice plant leaves. *Journal of the Japanese Society of Agricultural Machinery* 62(5), pp. 98-103
- [5] Heisel, T.; Schou, J.; Christensen, S.; Andreasen, C. (2001): Cutting weeds with a CO<sub>2</sub> laser. *Weed Res.* 41(1), pp. 19-29

- [6] Heisel, T.; Schou, J.; Andreasen, C.; Christensen, S. (2002): Using laser to measure stem thickness and cut weed stems. *Weed Res.* 42(3), pp. 242-248
- [7] Langner, H.R.; Ehlert, D.; Heisig, M.; Kirste, A. (2006): Thermische Wirkung von Laserstrahlung auf Pflanzen. *Landtechnik* 61(5), S. 252-253
- [8] Mathiassen, S.K.; Bak, T.; Christensen, S.; Kudsk, P. (2006): The effect of Laser Treatment as a Weed Control Method. *Biosystems Engineering* 95(4), pp. 497-505
- [9] Wöltjen, C.; Haferkamp, H.; Rath, T.; Herzog, D. (2008): Plant growth depression by selective irradiation of the meristem with CO<sub>2</sub> and diode lasers. *Biosystems Engineering* 101(3), pp. 316-324
- [10] Christensen, S.; Heisel, T.; Schou, J. (2003): Severing or damaging apparatus for unwanted plants comprises an optical recognition system that differentiates between different types of plants with a light generating source to expose the plant to electromagnetic radiation. AU 9948982-A; WO 200003589-A1; A01M 021/00.
- [11] Nadimi, E.S.; Andersson, K.J.; Jorgensen, R.N.; Maagaard, J.; Mathiassen, S.; Christensen, S. (2009): Designing, modelling and controlling a novel autonomous laser weeding system. 7<sup>th</sup> World Congress on Computers in Agriculture and Natural Resources, 22-24 June 2009, Reno, USA, pp. 299-303
- [12] Pastrana-Peréz, J.C.; Rath, T. (2008): Vision based plant recognition under overlapping situations. *Bornimer Agrartechnische Berichte* 62, S. 16-23

### Authors

**Prof. Dr. Thomas Rath** is the director of the Department of Biosystems and Horticultural Engineering at the Institute of Biological Production Systems of the Leibniz University of Hannover, Herrenhäuser Strasse 2, 30419 Hannover. There is also working M. Sc. Julio César Pastrana Pérez as a researcher in the field of image processing. **Prof. Dr.-Ing. Stephan Barcikowski** holds the chair of Technical Chemistry I, University of Duisburg-Essen held. **Prof. Dr.-Ing. Dr.-Ing. h.c. mult. Dr. h.c. Heinz Haferkamp** co-founded the Laser Zentrum Hannover e.V., Hollerithallee 8, 30419 Hannover, where **Dr. Michael Hustedt** head the group Safety Technology. **Dipl.-Ing. B. Sc. Christian Marx** is scientific assistant at both Hanoverian institutions. e-mail: marx@bgt.uni-hannover.de, c.marx@lzh.de

### Acknowledgements

The presented work was part of the research project "Studies on the effect of laser light based on image analysis on juvenile plants for weed control," which was funded by the German Research Foundation.