

# **Synthetic Studies Towards the SNAC Ester of *seco*-Progeldanamycin**

Von der Naturwissenschaftlichen Fakultät  
der Gottfried Wilhelm Leibniz Universität Hannover

zur Erlangung des Grades

**Doktor der Naturwissenschaften (Dr. rer. nat.)**

genehmigte Dissertation  
von

Christian Bartens, M. Sc.

2022

Referent: Prof. Dr. rer. nat. Andreas Kirschning  
Korreferent: Prof. Dr. rer. nat. Markus Kalesse  
Tag der Promotion: 14.07.2022

# Kurzzusammenfassung

*Christian Bartens*

## Synthetic Studies Towards the SNAC Ester of *seco*- Progeldanamycin

Schlagworte: Totalsynthese, Geldanamycin, *seco*-Progeldanamycin, Hsp90, Amidsynthasen, Arylamin-*N*-Acetyltransferasen (NAT), Chemoenzymatische Synthese

Das Ansamycinantibiotikum Geldanamycin wird von *Streptomyces hygroscopicus* durch eine PKS vom Typ I biosynthetisiert. Die Makrolaktamisierung in der Biosynthese wird von der Amidsynthase GdmF katalysiert. GdmF gehört zur Superfamilie der Arylamin-*N*-Acetyltransferasen.

In der vorliegenden Arbeit wurde eine konvergente Fragmentsynthese auf dem Weg zum SNAC-Ester von *seco*-Progeldanamycin, dem natürlichen Substrat von GdmF, entwickelt.

Für die Synthese der ersten Generation wurde eine Ringschlussmetathese für den Aufbau der zentralen dreifachsubstituierten Doppelbindung unter Zuhilfenahme einer vorübergehenden Verknüpfung (*tethering*) des West- und Ostfragmentes untersucht. Die Schlüsselschritte zur Synthese des Westfragments umfassten eine Evans-Alkylierung, eine Sharpless-Epoxidierung, sowie eine Roush-Crotylierung. Für die Synthese des Ostfragments wurde eine Zink-vermittelte chelatgesteuerte Isopropenylierung angewandt.

Die Synthese der zweiten Generation wurde konvergenter gestaltet. Hierfür wurde der aromatische Teil des Westfragments mittels 1,2-Addition und anschließender Barton-McCombie-Deoxygenierung eingeführt. Die Schlüsselschritte zur Synthese des Westfragments umfassten eine Myers-Alkylierung, sowie eine *anti,syn*-selektive Marshall-Propargylierung, gefolgt von einer Hydrozirkonierung-Iodinierungs-Sequenz. Die Kupplung an das Ostfragment erfolgte über eine achirale Nozaki-Hiyama-Kishi-Reaktion. Als Alternative zur Kupplung des West- und Ostfragments wurde eine Samariumdiodid-vermittelte Reformatzki-Reaktion untersucht.

Im zweiten Teil der Arbeit wurden verkürzte SNAC- und Pantetheinderivate des *seco*-Progeldanamycins synthetisiert, welche erfolgreich für Co-Kristallisationsexperimente mit GdmF verwendet wurden. Des Weiteren wurden nicht-hydrolysierbare Stickstoff- und Kohlenstoffanaloga synthetisiert. Letztere wurden mit Hilfe einer Nickel-katalysierten decarboxylativen Ketonsynthese hergestellt.

## Abstract

*Christian Bartens*

### **Synthetic Studies Towards the SNAC Ester of *seco*-Progeldanamycin**

Keywords: total synthesis, geldanamycin, *seco*-progeldanamycin, Hsp90, GdmF, amide synthases, arylamine *N*-acetyltransferases (NATs), chemoenzymatic synthesis

The ansamycin antibiotic geldanamycin is biosynthesized by *Streptomyces hygroscopicus* through a PKS type I. The macrolactamization in the biosynthesis is catalyzed by the amide synthase GdmF. GdmF belongs to the superfamily of arylamine *N*-acetyltransferases (NATs). In the present work, a convergent fragment synthesis towards the SNAC ester of *seco*-progeldanamycin, the natural substrate of GdmF, was developed.

For the first generation synthesis, a tethered ring closing metathesis of the western and eastern fragments was investigated to introduce the central trisubstituted double bond.

Key steps for the synthesis of the western fragment included Evans alkylation, Sharpless epoxidation, and Roush crotylation. For the synthesis of the east fragment, a zinc-mediated chelate-controlled isopropenylation was used.

The second generation synthesis was made more convergent. For this purpose, the aromatic moiety of the western fragment was introduced via 1,2-addition followed by Barton-McCombie deoxygenation. Key steps in the synthesis of the western fragment included Myers alkylation, and *anti,syn*-selective Marshall propargylation followed by a hydrozirconation-iodination sequence. Coupling to the eastern fragment occurred via an achiral Nozaki-Hiyama-Kishi reaction. As an alternative to coupling the western and eastern fragments, a samarium diiodide-mediated Reformatsky reaction was investigated.

In the second part of the work, truncated SNAC and pantetheine derivatives of *seco*-progeldanamycin were synthesized, which were successfully used for co-crystallization experiments with GdmF. Furthermore, non-hydrolyzable nitrogen and carbon analogs were synthesized. The latter were prepared using a nickel-catalyzed decarboxylative ketone synthesis.

# Table of Contents

|   |    |
|---|----|
| Kurzzusammenfassung.....  | I  |
| Abstract .....  | II |
| Preliminary Remarks.....  | 1  |
| List of Abbreviations.....  | 2  |
| 1 Introduction .....  | 5  |
| 1.1 Hsp90 as Target in Cancer Therapy .....                         | 5  |
| 1.2 Geldanamycin.....   | 6  |
| 1.2.1 Biosynthesis of Geldanamycin.....                             | 7  |
| 1.3 Arylamine <i>N</i> -Acetyltransferases (NATs) and GdmF.....     | 7  |
| 1.4 Chemoenzymatic Macrocyclizations in Polyketide Synthesis.....   | 12 |
| 2 Objective .....   | 16 |
| 3 Results and Discussion.....                                       | 17 |
| 3.1 Preliminary Works .....   | 17 |
| 3.2 First Generation Synthesis .....                                | 18 |
| 3.2.1 Ring-Closing Metathesis .....                                 | 18 |
| 3.2.1.1 Synthesis of Eastern Fragment 38.....                       | 19 |
| 3.2.1.2 Synthesis of Western Fragment 39.....                       | 20 |
| 3.2.1.3 Tethering and RCM.....                                      | 24 |
| 3.2.2 Transition Metal-Mediated Coupling.....                       | 27 |
| 3.3 Second Generation Synthesis .....                               | 33 |
| 3.3.1 Hydrozirconation-Iodination.....                              | 33 |
| 3.3.2 Nozaki-Hiyama-Kishi Coupling .....                            | 36 |
| 3.3.3 Halogen-Metal Exchange .....                                  | 40 |
| 3.3.4 Titanium Alkoxide-Mediated Reductive Coupling.....            | 43 |
| 3.3.5 Introduction of the Aromatic Moiety .....                     | 45 |
| 3.3.5.1 C(sp <sup>2</sup> )-(sp <sup>3</sup> ) Cross-Coupling ..... | 45 |
| 3.3.5.2 Lithiation-Borylation-Protodeboronation.....                | 53 |
| 3.3.5.3 1,2-Addition and Deoxygenation .....                        | 55 |
| 3.3.6 Reformatsky Reaction .....                                    | 63 |
| 3.4 Test Substrates for GdmF.....                                   | 65 |
| 3.4.1 SNAC and Pantetheine Thioesters .....                         | 66 |
| 3.4.2 Enzymatic Assays .....  | 67 |

|       |  |     |
|-------|--|-----|
| 3.4.3 | Non-Hydrolyzable Substrates .....            | 70  |
| 4     | Summary and Outlook .....                    | 77  |
| 5     | Experimental Part .....                      | 85  |
| 5.1   | General Information .....                    | 85  |
| 5.2   | Auxiliary Reagents and Building Blocks ..... | 86  |
| 5.3   | First Generation Synthesis .....             | 100 |
| 5.3.1 | Eastern Fragment.....                        | 100 |
| 5.3.2 | Western Fragment .....                       | 107 |
| 5.4   | Second Generation Synthesis .....            | 126 |
| 5.4.1 | Western Fragment .....                       | 126 |
| 5.4.2 | Arenes.....                                  | 147 |
| 5.5   | Reformatsky Approach .....                   | 155 |
| 5.6   | Test Substrates for GdmF.....                | 164 |
| 5.7   | Miscellaneous Reactions .....                | 187 |
| 6     | References .....                             | 196 |
| 7     | Appendix .....                               | 206 |
|       | Danksagung .....                             | 298 |
|       | Lebenslauf .....                             | 299 |
|       | Publikationen.....                           | 300 |

## Preliminary Remarks

In the schemes and figures in the following thesis, the numbering of the carbon atoms of the molecules is not used according to the IUPAC rules, but refers to the position in the carbon backbone of geldanamycin (**1**).

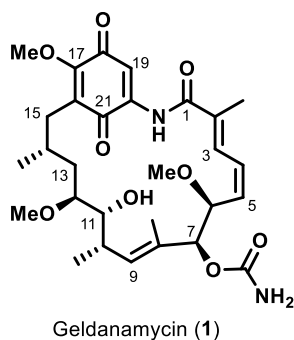

Furthermore, the absolute stereochemistry is depicted with wedged bonds. The use of wavy bonds indicates an indeterminate stereoconfiguration.



## List of Abbreviations

|              |   |
|--------------|---|
| 2,6-lutidine | 2,6-dimethylpyridine                      |
| Ac           | acetyl                                    |
| ACP          | acyl carrier protein                      |
| AHBA         | 3-amino-5-hydroxybenzoic acid             |
| app.         | apparent                                  |
| Ar           | aryl                                      |
| Asp          | aspartate                                 |
| AT           | acyltransferase                           |
| b.p.         | boiling point                             |
| Bn           | benzyl                                    |
| Boc          | <i>tert</i> -butoxycarbonyl               |
| BOM          | benzyloxymethyl                           |
| BPhen        | bathophenanthroline                       |
| brsm         | based on recovered starting material      |
| Bu           | butyl                                     |
| CAN          | ceric ammonium nitrate                    |
| CBS          | Corey-Bakshi-Shibata                      |
| CDI          | carbonyldiimidazole                       |
| CoA          | coenzyme A                                |
| cod          | cyclooctadienyl                           |
| COSY         | homonuclear correlation spectroscopy      |
| Crp          | cryptophycin                              |
| CSA          | camphorsulfonic acid                      |
| Cy           | cyclohexyl                                |
| Cys          | cysteine                                  |
| <i>d.r.</i>  | diastereomeric ratio                      |
| DBB          | 4,4'- <i>di-tert</i> -butylbiphenyl       |
| DcsB         | decastrictine C1                          |
| DDQ          | 2,3-dichloro-5,6-dicyano-1,4-benzoquinone |
| DET          | diethyl tartrate                          |
| DH           | dehydratase                               |
| DIAD         | <i>diisopropyl</i> azodicarboxylate       |
| DIBAL-H      | <i>diisobutylaluminium</i> hydride        |
| DIC          | <i>diisopropylcarbodiimide</i>            |
| DIPA         | <i>diisopropylamine</i>                   |
| DIPEA        | <i>N,N-diisopropylethylamine</i>          |
| DMAP         | 4-dimethylaminopyridine                   |
| DMF          | <i>N,N</i> -dimethylformamide             |
| DMP          | Dess-Martin periodinan                    |
| DMPU         | 1,3-dimethyl-1,3-diazinan-2-one           |
| DMSO         | dimethyl sulfoxide                        |
| DNA          | deoxyribonucleic acid                     |



|              |   |
|--------------|---|
| dppf         | 1,1'-bis(diphenylphosphino)ferrocen                           |
| EDC          | 1-ethyl-3-(3-dimethylaminopropyl)carbodiimide                 |
| EDTE         | ( <i>N,N,N',N'</i> -tetrakis(2-hydroxyethyl)ethylenediamine)  |
| EGFR         | epidermal growth factor receptor                              |
| eq.          | equivalents   |
| ER           | enoylreductase  |
| ESI          | electrospray-ionization                                       |
| Et           | ethyl   |
| <i>fpt</i>   | freeze-pump-thaw  |
| GABA         | $\gamma$ -aminobutyric acid                                   |
| GCMS         | gas chromatography mass spectrometry                          |
| Gdm          | enzyme involved in geldanamycin biosynthesis                  |
| <i>gdm</i>   | gene involved in geldanamycin biosynthesis                    |
| glyme        | dimethoxyethane   |
| HER          | human epidermal growth factor                                 |
| His          | histidine   |
| HMBC         | heteronuclear multiple-bond correlation spectroscopy          |
| HMDS         | hexamethyldisilazane  |
| HOBt         | hydroxybenzotriazole  |
| HPLC         | high pressure liquid chromatography                           |
| HRMS         | high resolution mass spectrometry                             |
| HSF          | heat shock factor   |
| Hsp          | heat shock protein  |
| HSQC         | heteronuclear single-quantum correlation spectroscopy         |
| <i>i</i> -Pr | <i>iso</i> -propyl  |
| KR           | $\beta$ -ketoacylreductase                                    |
| KS           | $\beta$ -ketoacyl synthase                                    |
| LAB          | lithium amidotrihydroborate                                   |
| LCMS         | liquid chromatography mass spectrometry                       |
| LD           | loading domain  |
| LDA          | lithium diisopropylamide                                      |
| lls          | longest linear sequence                                       |
| m.p.         | melting point   |
| m/z          | mass per charge   |
| Me           | methyl  |
| MOM          | methoxymethyl   |
| MS           | molecular sieves  |
| Ms           | mesylate  |
| MS/MS        | tandem mass spectrometry                                      |
| MTBE         | methyl <i>tert</i> -butyl ether                               |
| MTPA         | $\alpha$ -methoxy- $\alpha$ -trifluoromethylphenylacetic acid |
| n.d.         | not determined  |
| NAT          | <i>N</i> -acetyltransferase                                   |
| NBS          | <i>N</i> -bromosuccinimide                                    |
| NHK          | Nozaki-Hiyama-Kishi   |

|                            |  |
|----------------------------|--|
| NHPI                       | <i>N</i> -hydroxyphthalimide                       |
| NMO                        | <i>N</i> -methylmorpholine <i>N</i> -oxide         |
| NMR                        | nuclear magnetic resonance spectroscopy            |
| Nu                         | nucleophile  |
| o/n                        | overnight  |
| o2s                        | over 2 steps                                       |
| PE                         | petroleum ether                                    |
| PG                         | protection group                                   |
| Ph                         | phenyl   |
| pin                        | pinacol  |
| PKS                        | polyketide synthase                                |
| PMB                        | <i>para</i> -methoxybenzyl                         |
| PPTS                       | pyridinium <i>para</i> -toluenesulfonate           |
| proton-sponge <sup>®</sup> | <i>N,N,N',N'</i> -tetramethylnaphthalin-1,8-diamin |
| PTAB                       | trimethylammonium tribromide                       |
| Py                         | pyridine   |
| QTOF                       | quadrupole time-of-flight                          |
| R                          | residue  |
| RCM                        | ring-closing metathesis                            |
| Rdc                        | radicicol  |
| rt                         | room temperature                                   |
| SAR                        | structure-activity relationship                    |
| SM                         | starting material                                  |
| SNAC                       | <i>N</i> -acetylcysteamine                         |
| TAA                        | <i>t</i> -amyl alcohol                             |
| TBAC                       | tetra- <i>n</i> -butylammonium chloride            |
| TBAF                       | tetra- <i>n</i> -butylammonium fluoride            |
| TBAI                       | tetra- <i>n</i> -butylammonium iodide              |
| TBDPS                      | <i>tert</i> -butyldiphenylsilyl                    |
| TBS                        | <i>tert</i> -butyldimethylsilyl                    |
| TE                         | thioesterase                                       |
| TES                        | triethylsilyl                                      |
| Tf                         | trifluoromethylsulfonyl                            |
| TFA                        | trifluoroacetic acid                               |
| THF                        | tetrahydrofuran                                    |
| TIPS                       | <i>triisopropylsilyl</i>                           |
| TLC                        | thin layer chromatography                          |
| TMEDA                      | <i>N,N,N,N</i> -tetramethylethylenediamine         |
| TMS                        | trimethylsilyl                                     |
| UPLC                       | ultra performance liquid chromatography            |
| UV                         | ultra violet                                       |
| <i>var.</i>                | variety  |
| VEGF                       | vascular endothelial growth factor                 |
| WHO                        | world health organization                          |
| Zea                        | zearalenone  |

# 1 Introduction

Cancer is the leading cause of death globally. The World Health Organization (WHO) estimated 18.1 million new cancer cases and 9.6 million cancer deaths for 2018.<sup>[1]</sup> The extensive research in anti-cancer drug discovery over the last decades led to the finding of many potential drugs for the treatment of malignancy. These chemotherapeutic drugs directly interfere with cell division, often at the level of DNA. Well known examples are Cisplatin (DNA damage), Gemcitabine (nucleoside analog) and Docetaxel (microtubules stabilizer). A major drawback of these chemotherapeutics is the lack of differentiation between tumor and normal cells. While intensive combinations of cytotoxic chemotherapies resulted in cures in some cases, these combination approaches have proven to be too toxic for most cancer patients.<sup>[2]</sup> Advances in genomics and the growing understanding of the molecular and biochemical alterations that occur during malignancy paved the way towards targeted cancer therapies.<sup>[3]</sup> The identification of distinct molecular characteristics that make cancer cells unique from normal cells has led to the development of new anti-cancer therapies selectively targeting these cancer-related genetic lesions. One of the most prominent targets is the cellular signal transduction machinery, more specifically, the protein kinases. These enzymes play an important role in cellular signaling cascades. Some of the most important targets of this superfamily of proteins are the human epidermal growth factor receptor (HER-2), vascular endothelial growth factor (VEGF-2) and the epidermal growth factor receptor (EGFR). Another target are oncogenic support processes such as protein chaperoning. One of the most promising targets is the molecular chaperone heat shock protein 90 (Hsp90).

## 1.1 Hsp90 as Target in Cancer Therapy

Stress conditions such as heat, hypoxia, oxidative stress, toxin exposure or nutrient deprivation in cells could cause protein misfolding, unfolding or aggregation. To maintain the appropriate folding of client proteins and to protect them from proteolysis, the gene transcription of specialized proteins, so-called molecular chaperones, is induced.<sup>[4,5]</sup> Ritossa was the first to describe this stress-induced protein synthesis in the year 1962. In experiments with *Drosophila buschii* larvae that were subjected to a temperature shock, the increased synthesis of proteins was observed, thus referred to as heat shock proteins (Hsps).<sup>[6]</sup> The Hsp gene transcription is mediated by heat shock factor 1 (HSF1). Upon stress conditions HSF1 can bind to the 5'-promoter regions of all Hsp genes and trigger instantaneous and extensive transcription of these stress genes.<sup>[7,8]</sup> The detailed mechanisms of the activation of Hsp genes are still under investigation. However, it is known that HSF1 in its inactive form is mainly located in the cytosol and is thought to be repressed by Hsp90 under growth conditions.<sup>[9]</sup> Stress reverses the repression and permits HSF1 activation by the formation of a HSF1 homotrimer which moves toward a nuclear localization to bind the promoter of Hsp genes.<sup>[10,11]</sup>

Among the heat shock proteins Hsp90 is one of the most conserved Hsps being present from bacteria to mammals. It has been speculated that this ubiquitously expressed molecular chaperone assists up to 10% of all cytosolic proteins at some stage of their life cycle.<sup>[12]</sup> Hsp90 performs essential housekeeping functions by controlling the folding, function,

stability, activation and proteolytic turnover of the client protein in the eukaryotic cell. Up until today more than 200 client proteins have been identified.<sup>1</sup> The variety of client proteins spans over kinases, transcription factors and an array of signaling molecules, involved in a wide range of biological processes. It is proven that several of these Hsp90 clients are oncoproteins linked to the six hallmarks of cancer.<sup>[13,14]</sup> The hallmarks defined by Hanahan and Weinberg are the evasion of apoptosis, sustained angiogenesis, limitless replicative potential, tissue invasion and metastasis, self-sufficiency in growth signals and insensitivity to anti-growth signals.<sup>[15]</sup> Since tumor cells experience constant levels of high stress, the Hsp90 induction is increased in these cells. The increased chaperone activity allows tumor cells to cope with the imbalanced conditions and thereby escape apoptotic death that would normally ensue.<sup>[16]</sup> As a result, cancer cells are, in a sense, addicted to Hsp90.<sup>[17]</sup> Thus, the inhibition of Hsp90 can lead to the depletion of a group of client proteins causing the simultaneous suppression of multiple oncogenic pathways.<sup>[18–20]</sup> This central role of Hsp90 lead to a great interest in discovering and developing specific Hsp90 inhibitors.

## 1.2 Geldanamycin

An important Hsp90 inhibitor is the benzoquinone ansamycin antibiotic geldanamycin (**1**). By binding to the *N*-terminal ATP-binding pocket, it inhibits the inherent ATPase activity of Hsp90, which is essential to its *in vivo* function.<sup>[21,22]</sup> Although geldanamycin showed high antitumor activity against various human cell line *in vitro*<sup>[23]</sup> it failed in clinical trials due to limited *in vivo* stability, severe hepatotoxicity and low solubility in aqueous solutions.<sup>[24]</sup> However, the C-17-amino analogs of geldanamycin 17-AAG (**2**), 17-DMAG (**3**) and 17-AG (**4**) (Figure 1) have been administered in clinical trials, with 17-AAG as the most advanced product entering a Phase 3 trial.<sup>[25]</sup>

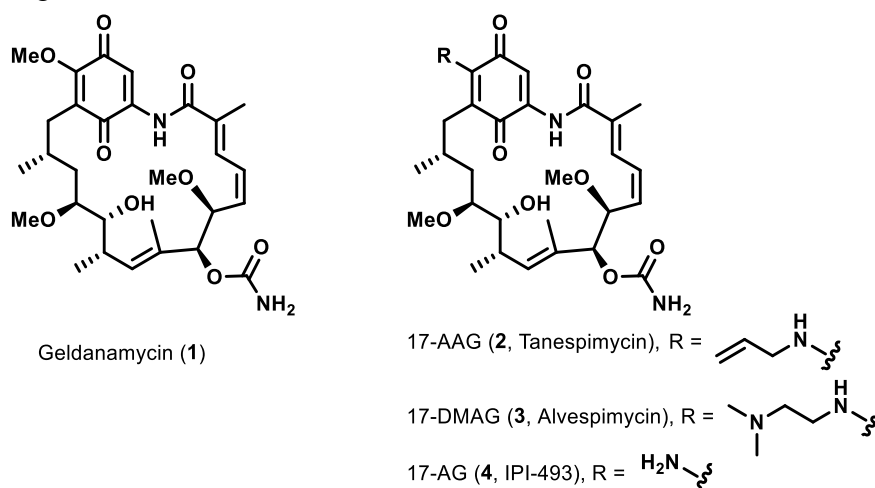

**Figure 1:** Structures of geldanamycin (**1**) and the geldanamycin derivatives 17-AAG (**2**), 17-DMAG (**3**), 17-AG (**4**).

The great potential of geldanamycin Hsp90 inhibitors is evident from the interest and effort that researchers have put into the still ongoing development and improvement of these drugs over the past decades. Only recently have new applications been opened up that go beyond

<sup>1</sup> The Picard group provides a comprehensive overview about the protein-protein interaction network of the human Hsp90 molecular chaperone machinery. The database is publicly available at <http://www.picard.ch/Hsp90Int>. More information regarding the underlying details of the database are given in the literature.<sup>[225]</sup>

use as antitumor agents. The two ansamycins 17-AAG and 17-DMAG showed promising activity against protozoan pathogens such as *Trypanosoma brucei*, which causes African sleeping sickness, and the malaria parasite *Plasmodium falciparum*.<sup>[26]</sup>

### 1.2.1 Biosynthesis of Geldanamycin

Geldanamycin is produced by the microorganism *Streptomyces hygroscopicus* which uses a modular polyketide synthase (PKS) type I and further post-PKS enzymes (Scheme 1, A).<sup>[27,28]</sup> As for all ansamycins<sup>[29]</sup>, biosynthesis begins with 3-amino-5-hydroxybenzoic acid (AHBA, **5**) as starter unit which is derived from the aminoshikimate pathway.<sup>[30]</sup> After the starter unit is recognized by the loading domain (LD) and transferred to the acyl carrier protein (ACP), the complete ketide chain is built by seven iterative modules that are encoded by the genes *gdmA1-gdmA3*. The elongation occurs by decarboxylative thio-Claisen condensations of malonyl-, methylmalonyl, and methoxymalonyl-CoA units. The C-C-bond formation is catalyzed by the  $\beta$ -ketoacyl synthase (KS), whereas the CoA units are introduced by the acyltransferase (AT) (Scheme 1, B). Tailoring enzymes such as the  $\beta$ -ketoacylreductase (KR), dehydratase (DH) and enoylreductase (ER) carry out further modifications on the ketide chain. Once the fully assembled polyketide chain has arrived at the most downstream carrier protein, it has to be released in order to regenerate the multienzyme complex for the next catalytic cycle. In the case of the ansamycins, cleavage from the PKS is accompanied by macrolactamization. This cyclization constrains the polyketides into their bioactive conformations. Accordingly, macrolactamization represents an extremely important point within biosynthesis. In many polyketide biosynthetic clusters, the release of the final product is catalyzed by a thioesterase (TE) domain that is integrated into the PKS machinery. However, the biosynthetic assembly line of geldanamycin lacks a thioesterase domain. Instead, the release from the PKS and the macrolactamization furnishing progeldanamycin (**6**) is catalyzed by the external amide synthase GdmF. To date, however, it is unclear whether macrolactam formation occurs directly with ACP-bound *seco*-progeldanamycin (**7**) or whether the substrate must be activated as another thioester to be accepted as a substrate of GdmF. After *seco*-progeldanamycin is released from the PKS, several post-PKS tailoring enzymes perform the final modifications that deliver geldanamycin (**1**) and complete the biosynthesis.<sup>[31,32]</sup>

## 1.3 Arylamine *N*-Acetyltransferases (NATs) and GdmF

Despite the important role in the biosynthesis, little is known about the amide synthase GdmF. Homology modelling revealed, that GdmF belongs to the highly conserved superfamily of arylamine *N*-acetyltransferases (NATs), although sequence homology is rather low.<sup>[33,34]</sup> NATs are intracellular xenobiotic-metabolizing enzymes that catalyze the acetyl-CoA-dependent *N*-acetylation of arylamines and arylhydrazines and the *O*-acetylation of *N*-arylhydroxylamines.<sup>[35–37]</sup> These enzymes are expressed in organisms from bacteria and fungi to vertebrates. In humans, NATs are important for the metabolism of drugs and have been shown to acetylate and inactivate several antibacterial compounds such as the frontline anti-tuberculosis drugs isoniazid and *p*-aminosalicylate.<sup>[35,38]</sup> In several prokaryotes, NATs contribute to defense mechanisms towards environmental toxins that are present in the different habitats of bacteria.<sup>[39]</sup>

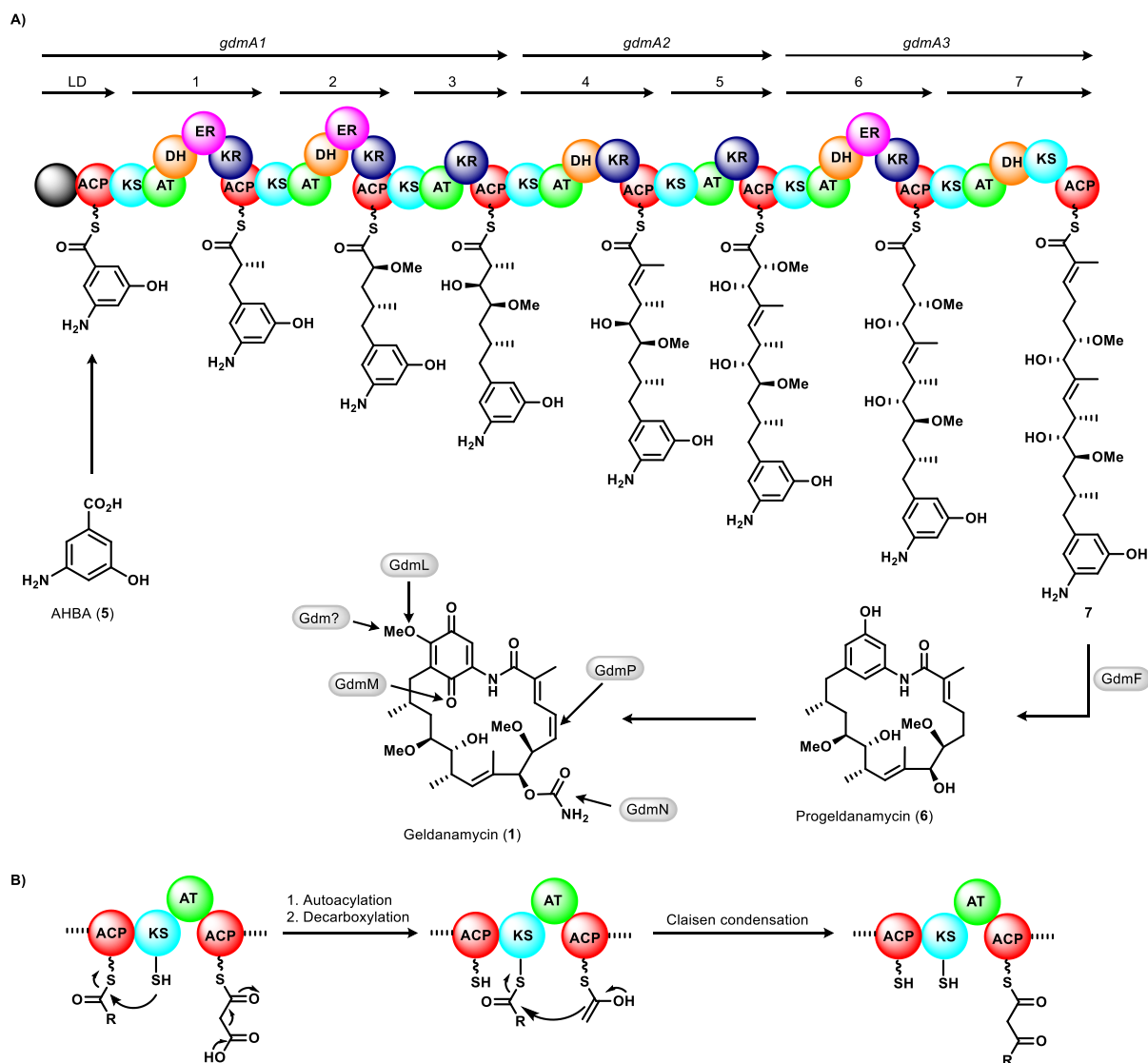

**Scheme 1: A)** The geldanamycin biosynthesis in *Streptomyces hygroscopicus*. **B)** General mechanism of polyketide synthesis via Claisen condensation. LD: loading domain; ACP: acyl carrier protein; KS: ketosynthase; AT: acyltransferase; DH: dehydratase; ER: enoylreductase; KR: ketoreductase.

Furthermore, some bacterial NATs have been shown to acetylate and thereby inactivate various antibiotics.<sup>[40–42]</sup> X-ray structural analysis elucidated the presence of a cysteine protease-like cysteine-histidine-aspartate (Cys-His-Asp) catalytic triad, which is highly conserved in NAT homologous.<sup>[33,43]</sup> The transfer of the acetyl group was shown to follow a “ping-pong bi-bi” reaction mechanism (Figure 2).<sup>[44–46]</sup> In a “ping-pong bi-bi” mechanism, two substrates A and B (“bi”) are converted into two products P and Q (“bi”). First, substrate A binds to the enzyme (E), whereupon product P is released (“ping”). Usually, product P is a fragment of the original substrate A. The rest of the substrate remains covalently attached to the enzyme (F). Then, the second substrate B is taken up by the enzyme and a covalent bond is formed to the remaining fragment of A that is still bound to the enzyme. Eventually the product Q is released and the enzyme is restored to its initial form (“pong”).

In the case of NATs, the acetyl group is first transferred from the cofactor acetyl-coenzyme A (acetyl-CoA) to the sulfhydryl group of the active site cysteine, forming a covalent acetyl-enzyme intermediate, a cysteinyl thioester (Scheme 2, steps A to C, “ping”).

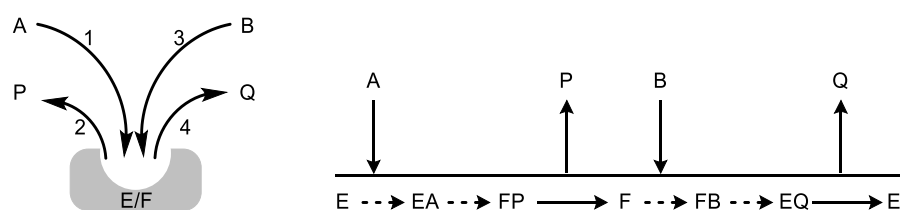

**Figure 2:** Schematic ping-pong bi-bi catalytic mechanism. Downward arrows indicate uptake; upward arrows indicate release; A = first substrate; B = second substrate; P = first product; Q = second product; E = enzyme; F = isoform of E; EA, FP, FB and EQ indicate transition complexes.

Release of the product CoA is therefore the first irreversible step in the catalysis (step C). The acetyl group is then transferred from the enzyme to the acceptor substrate (steps D to F, “pong”).

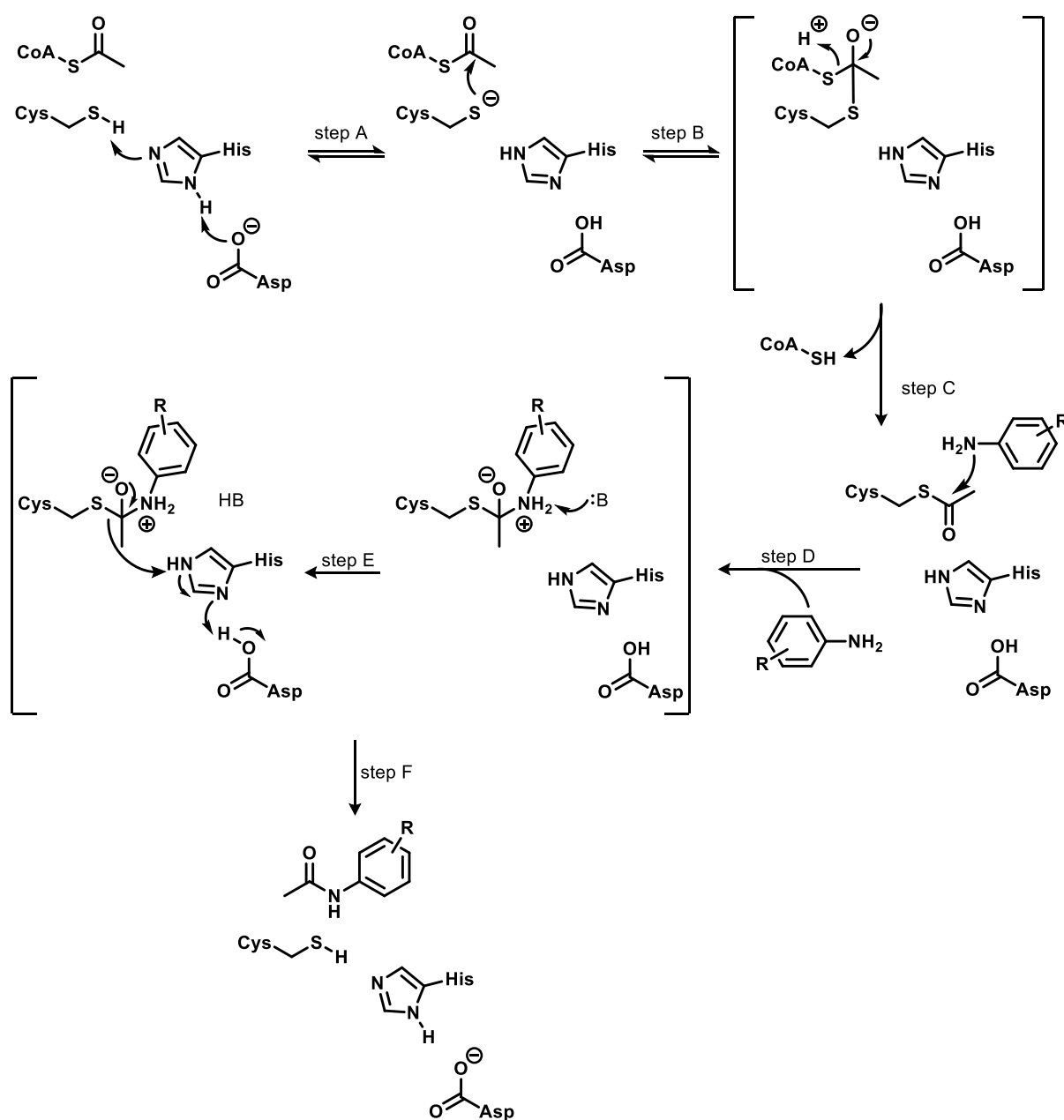

**Scheme 2:** Proposed NAT catalytic mechanism following a ping-pong bi-bi mechanism.

The catalytic triad is an essential feature of all enzymes active in acetyl-transfer from acetyl-CoA. All NAT enzymes have a similar fold which consists of three domains of approximately equal length. The first two domains, an  $\alpha$ -helical bundle and a  $\beta$ -barrel, are connected to the third domain, an  $\alpha/\beta$ -lid, via a linker helix (Figure 3).<sup>[43]</sup>

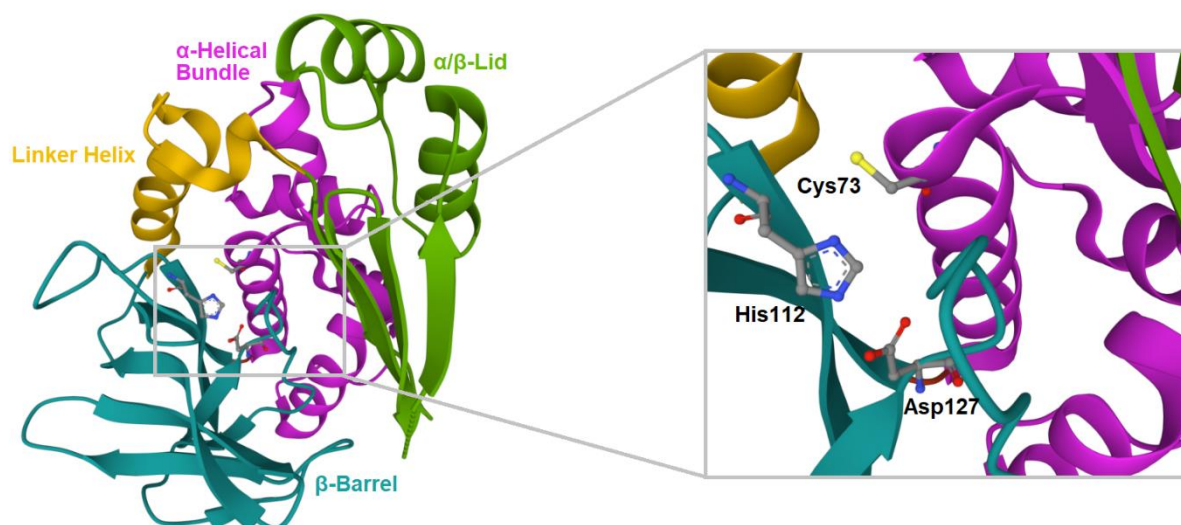

**Figure 3:** Structure of the arylamine *N*-acetyltransferases and the catalytic Cys-His-Asp triad depicted by the NAT1-structure from *Mesorhizobium loti*.<sup>[47]</sup> The figure was created using protein databank (PDB) code 2BSZ.

The structural motifs formed by the  $\alpha$ -helical bundle and a  $\beta$ -barrel share homology with deubiquitinating enzymes, transglutaminases and the papain-like cysteine proteases family, suggesting that they have evolved from the same ancestor.<sup>[33,48]</sup> In contrast, the  $\alpha/\beta$ -lid shows lower sequence conservation and also varies in length, charge and flexibility properties between different NATs.<sup>[49]</sup> When comparing eukaryotic and prokaryotic NAT structures, further differences become apparent. For example, the C-terminal region of (HUMAN)NAT1 and (HUMAN)NAT2 consists of a randomly coiled region that extends deep into the vicinity of the catalytic triad and is involved in the formation of the substrate binding pocket.<sup>[50]</sup> In bacterial NATs, on the other hand, the C-terminus forms an  $\alpha$ -helix that is far from the active site.<sup>[51]</sup> Furthermore, the human NATs possess the so-called “mammalian-like insertion”, which is a 17-residue extension within the  $\beta$ -barrel domain.

Although the role of this extension is not fully elucidated, protein structures suggest that the extension contributes to the mode of binding of acetyl-CoA or serves to structurally integrate the protein by interacting with other residues in the protein.<sup>[50]</sup> The structural differences between eukaryotic and prokaryotic NATs is depicted in Figure 4 by the comparison of (HUMAN)NAT2 and (MYCMR)NAT1 from *Mycobacterium marinum*. Both structures show a significantly different binding mode of the cofactor CoA. The mode of binding depends on the shape of the active site and at least partly on the presence of the “mammalian-like” insertion which constrains the adenosine part of CoA.<sup>[52]</sup>

The active site which appears as a deep cleft is mainly formed by the  $\beta$ -barrel and the  $\alpha/\beta$ -lid. Nevertheless, the  $\alpha$ -helical bundle is also involved as it provides the catalytic cysteine. The active site is relatively hydrophobic overall due to the hydrophobic nature of the  $\beta$ -barrel. And especially in the deepest part of the active site, where the catalytic cysteine is located, several phenylalanine and tryptophan residues cause a strongly hydrophobic environment.<sup>[33]</sup>



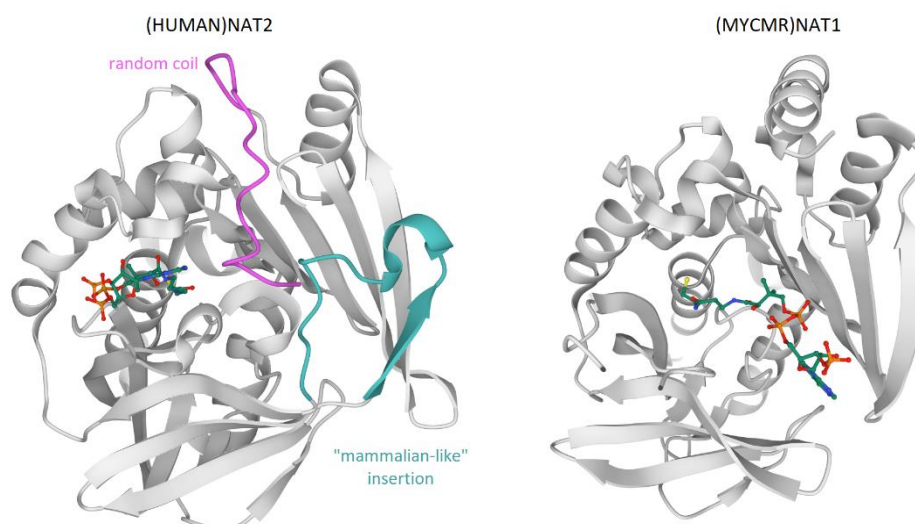
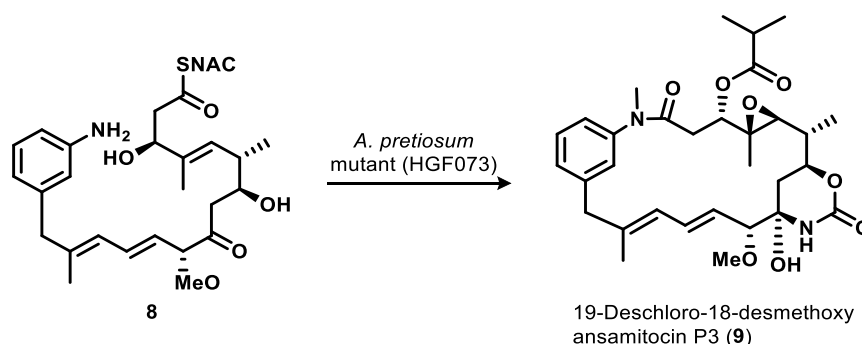

**Figure 4:** Differences in NAT structural features. Coenzyme A binding, the “mammalian-like” insertion and the random coil are depicted by comparison of (HUMAN)NAT2 and (MYCMR)NAT1 from *Mycobacterium marinum*. The structures show the CoA cofactor as ball stick model in green. The “mammalian-like” insertion is highlighted in petrol and the random coil in magenta. The figure was created using protein databank (PDB) codes 2PFR and 2VFC.

Interestingly, co-crystallizations with NAT enzymes and acetyl-CoA revealed several different binding modes of the cofactor. The distances between the cofactor’s adenosine residue and the cysteamine residue varied from 9.4 Å to 20 Å. As a result, the size and shape of the active site varies significantly between different NATs. A good example is the comparison of human NAT1 and NAT2. In the latter, Phe129 and Tyr129 residues are replaced by Ser residues, resulting in a substrate binding pocket almost 60% larger than in NAT1. Consequently, NAT2 can accommodate and acetylate bulkier substrates than NAT1.

In general, it is not clear which residues are critical for substrate recognition. However, the differences in size and shape of the active site contribute to the substrate specificity of NAT enzymes. Moreover, the dual dependence on active site architecture and substrate structure leads to different, but often overlapping, substrate specificities between NATs.

Despite the structural similarities of the amide synthase GdmF to other members of the NAT family, the inherent macrocyclizing activity of GdmF is very different from the activity of other NATs. In addition to *S. hygroscopicus*, other *Streptomyces* and related species contain genes that are homologous to *nat* genes and encode amide synthases that catalyze macrocyclizations. For example, in the ansamitocin producer *Actinosynnema pretiosum* the amide synthase Asm9 is encoded by *asm9* and in the rifamycin producer *Amycolatopsis mediterranei* RifF is encoded by *rifF*.<sup>[53–56]</sup> Mutasynthetic experiments with blocked mutants of *S. hygroscopicus* and *A. pretiosum* showed an unusual promiscuity of the two amide synthases GdmF and Asm9.<sup>[32,57,58]</sup> 18-Deoxy *seco*-acid **8**, activated as the corresponding *N*-acetylcysteamine (SNAC) thioester, was fed to a mutant strain (HGF073) of *A. pretiosum*, whereupon the ansamitocin P3 derivative **9** could be isolated (Scheme 3).



**Scheme 3:** Feeding of 18-deoxy *seco*-acid **8** to the blocked mutant strain HGF073 of *A. pretiosum* resulting in the formation of 19-deschloro-18-desmethoxy ansamitocin P3 (**9**).<sup>[32,57,58]</sup>

However, these studies failed to elucidate the still unknown mode of activation of the *seco*-acid substrate. The SNAC thioester might have been loaded onto the ACP moiety of the final PKS module or converted by transesterification into a hitherto unknown activated ester. As mentioned above, most known NATs involve CoA as the acetyl-carrying cosubstrate. Interestingly, comparison of the binding mode of CoA to the prokaryotic *Mycobacterium marinum* NAT<sup>[59]</sup> and human NAT2<sup>[50]</sup> revealed two distinct binding modes. Considering that the structural motifs in amide synthases are quite similar to NATs, but the residues involved in CoA binding are not conserved across the amide synthases, it is likely that there could be a completely new binding mode that does not require a CoA intermediate.<sup>[59]</sup>

Just recently, the first crystal structure<sup>2</sup> of the amide synthase GdmF was obtained and diffracted to a resolution of 1.4 Å.<sup>[60]</sup> It was shown, that the tertiary structure of GdmF is very similar to that of NAT enzymes and has the typical structural features, such as the  $\alpha$ -helical bundle, the  $\beta$ -barrel and the  $\alpha/\beta$ -lid. The catalytic Cys-His-Asp triad in the active site also shows the same arrangement. Differences were found in the interdomain region connecting the  $\beta$ -barrel and the  $\alpha/\beta$ -lid. Instead of the linker-helix common in NATs, the interdomain region in GdmF represents an unstructured, flexible loop whose structure has not yet been fully elucidated. This structural alteration results in a widened active site cleft. Molecular dynamics simulations and docking analyses of the protein with its native substrate *seco*-progeldanamycin suggested a possible gating-function of the interdomain region which facilitates substrate binding as well as macrolactam formation.

## 1.4 Chemoenzymatic Macrocyclizations in Polyketide Synthesis

Most enzymatic domains in natural product biosynthesis display an intrinsic selectivity for the substrate and remain inactive until the correct selection criteria are met. In the literature these domains are termed gate-keepers, decision gates or logic gates, whereby all of these terms are used synonymously.<sup>[61]</sup> With regard to amide synthases and thioesterases, logic gates represent the verification of key properties during the loading and release steps. Properties such as size, shape, electronics and rigidity of the substrate are evaluated by enzyme-substrate interactions and together with factors from the upstream pathway (i.e. external to the enzyme) restrictions on the loading or release can be placed. All these factors combined, enzyme-based

<sup>2</sup> Crystal structures of GdmF can be found in the PhD thesis of Wiebke Ewert<sup>[60]</sup> and will also be published in the near future.<sup>[178]</sup>

and external, are the logic gates that influence the decision to load or release the substrate. Understanding the substrate requirements of each logic gate would allow predictions regarding substrate loading and release. This applies for both natural and engineered *in vivo* or *in vitro* pathways as well as for chemoenzymatic contexts.

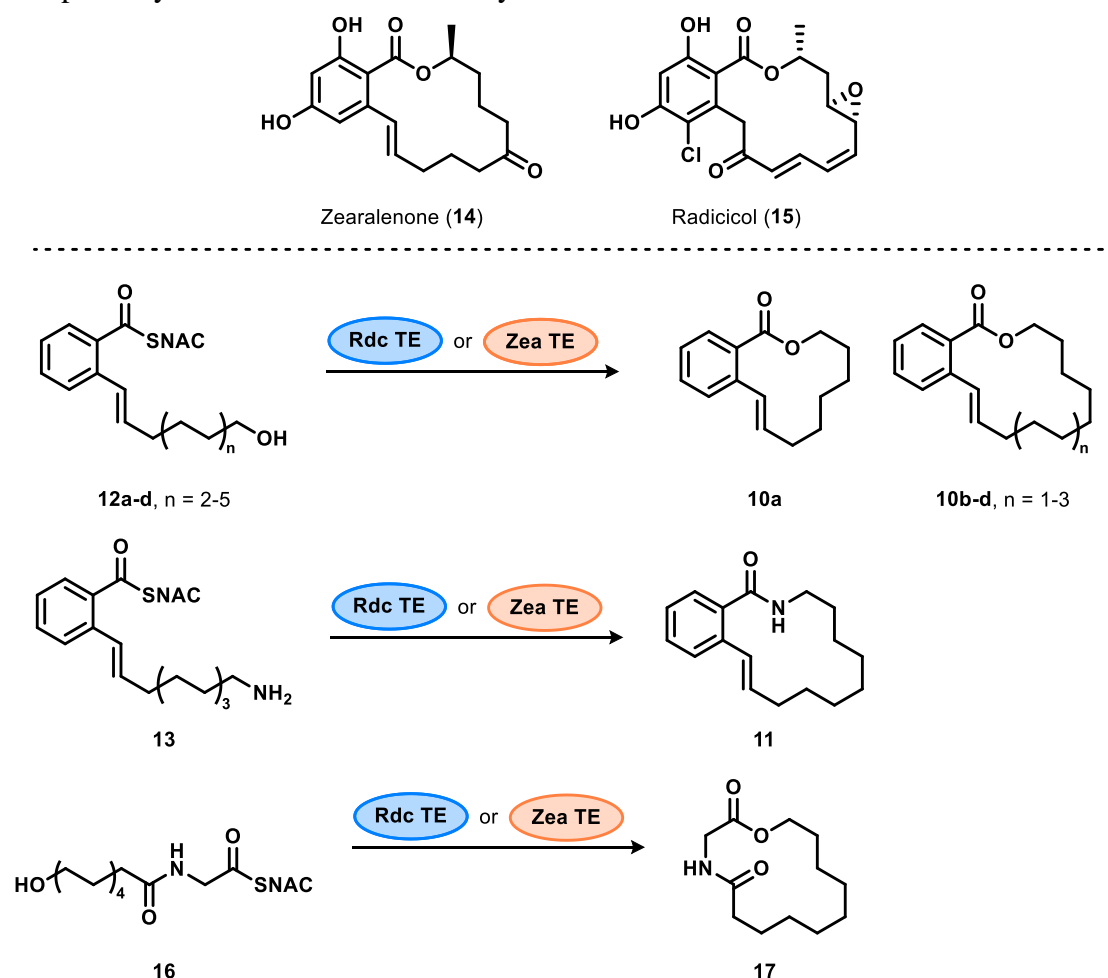

**Scheme 4:** Macrocyclizations catalyzed by the zearalenone thioesterase (Zea TE) and radicol thioesterase (Rdc TE).<sup>[69]</sup>

Chemists are increasingly considering the use of biocatalysis to develop scalable routes to target molecules, including second-generation manufacturing processes. Biocatalysis offers significant advantages in this regard, including reductions in production costs, number of synthesis steps, and environmental impact, as well as improved safety and selectivity. A notable aspect of biocatalysis is the ability to rapidly generate novel enzymes that can then be optimized for a specific substrate and reaction environment. Biocatalysis can make the use of protecting groups redundant, thereby removing additional wasteful steps from chemical synthesis. Indeed, an enzyme can be considered a combination of a catalyst and a directing or protecting group, as enzymes usually catalyze a transformation with exquisite regioselectivity and diastereoselectivity. Chemoenzymatic methods combine the flexibility of chemical synthesis and the efficiency and selectivity of enzymatic methods. Among various transformations catalyzed by an enzyme, chemoenzymatic macrocyclizations are of great interest to chemists, because macrocycles limit the conformational flexibility of small molecules, often enhancing their ability to bind selectively and with high affinity to a target. This makes them a preferred structure in drug discovery. While there are numerous examples of macrocyclizations of nonribosomal peptides using biocatalysts<sup>[62–68]</sup>, late stage

chemoenzymatic macrocyclization of polyketides is a rather unexplored field. Reports on the successful application of a single independent enzyme for the cyclization of advanced ketide chains are scarce.

Boddy *et al.*<sup>[69,70]</sup> described the synthesis of resorcyate-like 12- to 18-membered macrolactones (**10a-d**) and a 14-membered macrolactam (**11**) from acyclic SNAC esters (**12a-d**, **13**) using the thioesterase (TE) domains from the zearalenone (**14**) and radicicol (**15**) biosynthesis as biocatalysts (Scheme 4).

In addition, these TEs displayed a high substrate tolerance, as a non-resorcyate containing depsipeptide (**16**) was also successfully cyclized to give macrolactone **17**.

In 2021 Tang *et al.*<sup>[71]</sup> reported the formation of medium-ring lactones (**18a-c** and **19a-g**) by means of the thioesterase DcsB from the decarestrictine C1 (**20**) biosynthetic pathway (Scheme 5). DcsB showed broad substrate promiscuity toward linear substrates (**21a-c** and **22a-g**) that vary in lengths and substituents. It is noteworthy, that especially the synthesis of 8-11 membered lactones is significantly more challenging compared to small- and large-ring compounds. This is due to a nearly six orders of magnitude slower reactivity resulting from a steep increase in activation energy due to entropic and enthalpic penalties.<sup>[72-74]</sup>

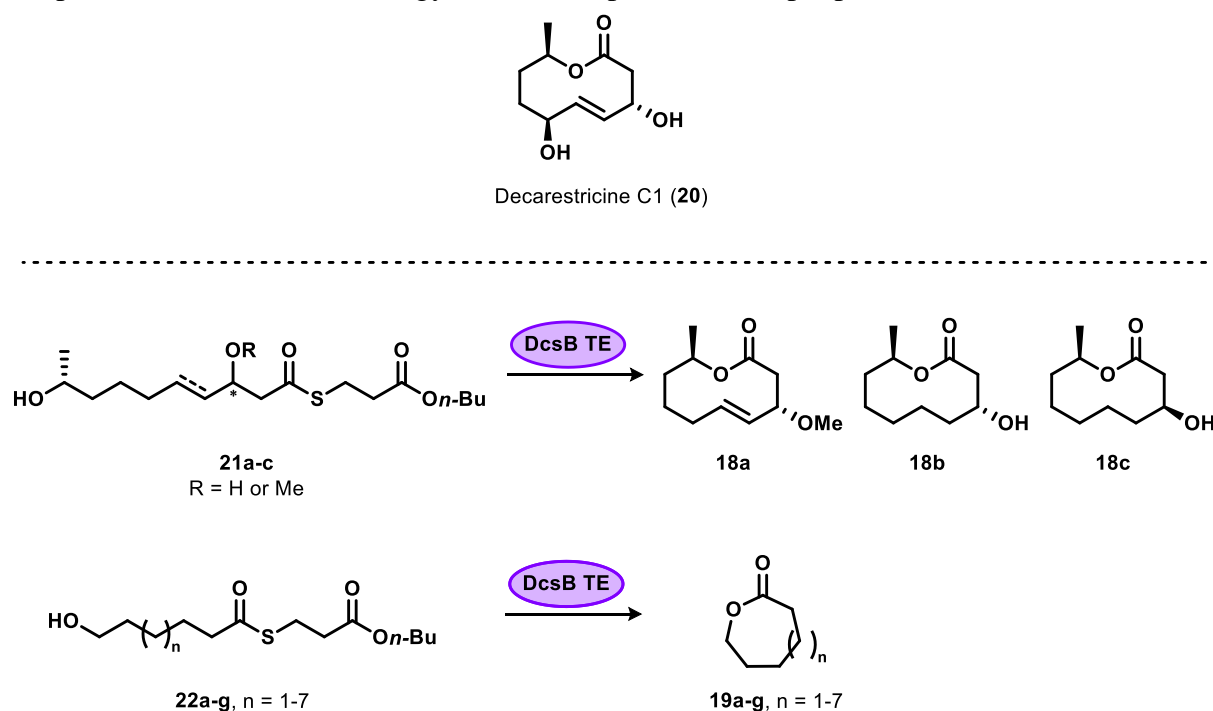

**Scheme 5:** Macrocyclizations catalyzed by the decarestrictine C1 thioesterase (DcsB TE).<sup>[71]</sup>

While the aforementioned examples showed the cyclization of rather simple substrates, in this group the chemoenzymatic macrocyclization of a much more complex polyketide was successfully performed.<sup>[75]</sup> For this purpose, 8-desmethyl-*seco*-progeldanamycin SNAC ester (**23**) was prepared by total synthesis and subsequent macrolactamization was catalyzed by the heterologously expressed amide synthase GdmF to give the corresponding macrolactam 8-desmethyl-progeldanamycin (**24**) (Scheme 6).

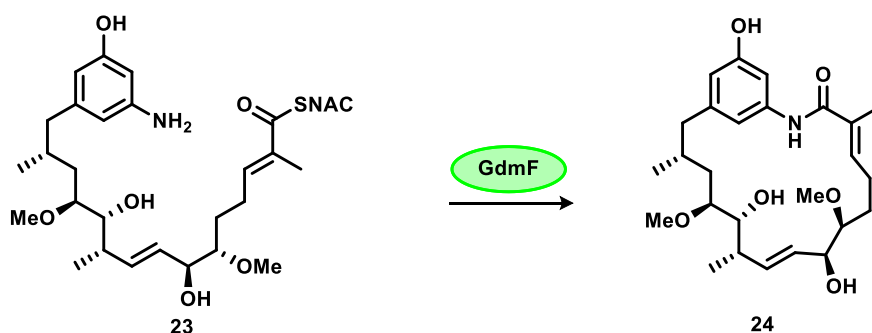

**Scheme 6:** Chemoenzymatic macrolactamization of 8-desmethyl-*seco*-progeldanamycin SNAC ester (**23**) catalyzed by amide synthase GdmF.<sup>[75]</sup>

Recently, the Sherman group also reported the chemoenzymatic cyclization of a more complex substrate. In their work, they generated a series of cryptophycin analogs (**25a-j** and **26a-c**).<sup>[76]</sup> They synthesized a series of novel cryptophycin chain elongation intermediates (**27a-j** and **28a-c**) and cyclization was carried out using the cryptophycin thioesterase (Crp TE) (Scheme 7). Even though cryptophycin (**29**) is produced in nature by a hybrid PKS/NRPS system, the results should be mentioned here.

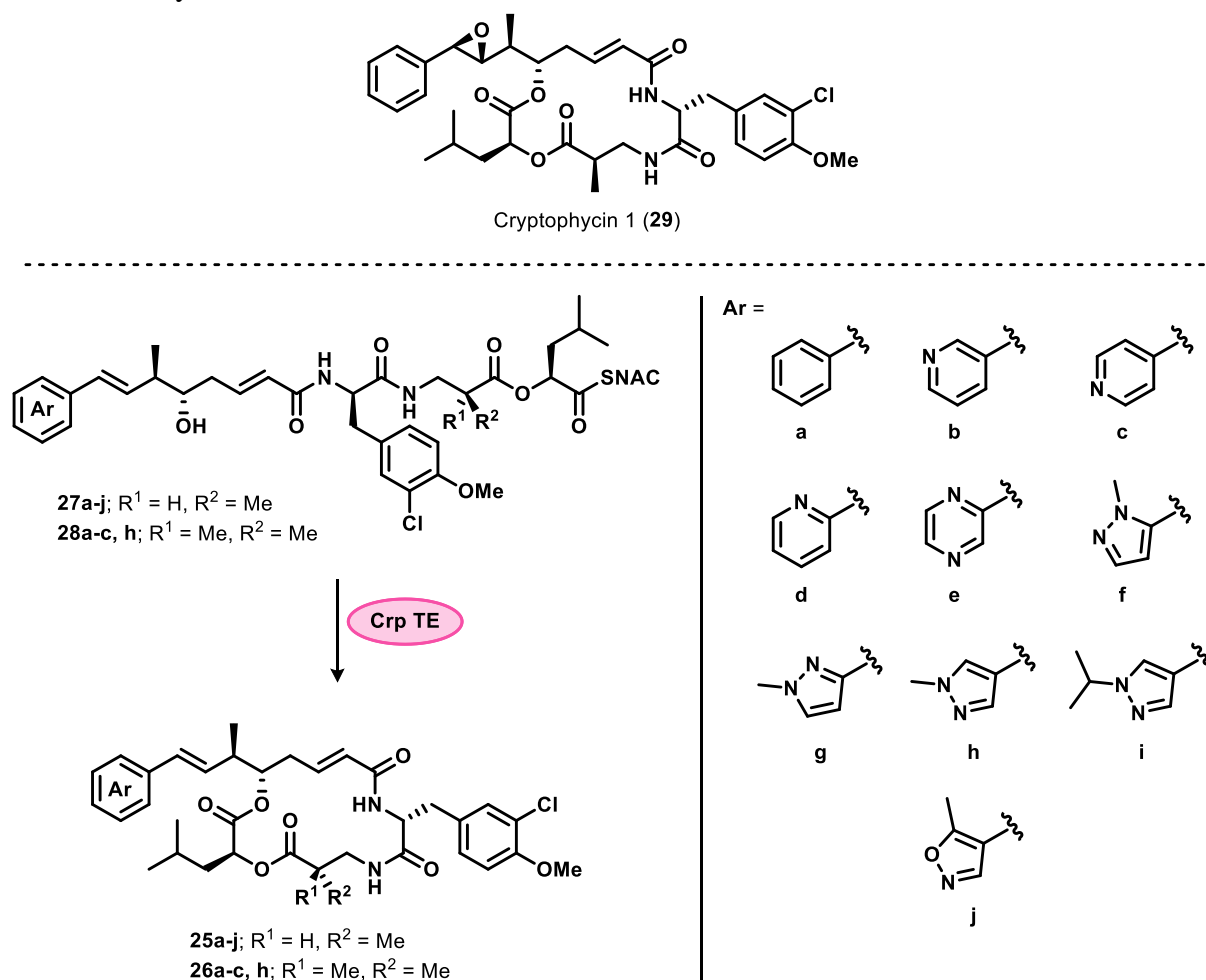

**Scheme 7:** Macrocyclizations catalyzed by the cryptophycin thioesterase (Crp TE).<sup>[76]</sup>

## 2 Objective

GdmF plays an important role in the biosynthesis of geldanamycin as it catalyzes the macrolactamization step. Chemically, these kinds of transformations tend to be challenging due to the reduced nucleophilicity of the aniline. Here, this enzyme could be used as a chemobiosynthetic tool in total synthesis to achieve such demanding transformations. The successful heterologous expression of the amide synthase GdmF in our group paved the way to pursue this idea further.<sup>[75]</sup> Structure-activity relationships (SARs) and studies on the substrate flexibility of GdmF are required to investigate the necessary structural requirements of the substrate for GdmF to be used as a tool. For these studies, *seco*-progeldanamycin, the natural substrate of GdmF, is needed.

The aim of this work is to develop a reliable synthetic strategy towards the SNAC ester of *seco*-progeldanamycin (**30**, Figure 5). The modification as SNAC ester serves to mimic the phosphopantetheinyl group of the PKS-bound substrate. It was shown that this modification can achieve higher acceptance of the substrate by the enzyme both *in vitro* and *in vivo*.<sup>[77]</sup> A convergent approach will be pursued to reduce the number of linear steps in the reaction sequence and allow easy diversification of substrates in the future.

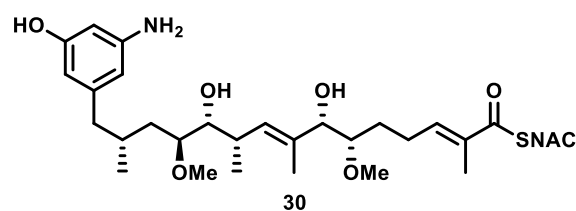
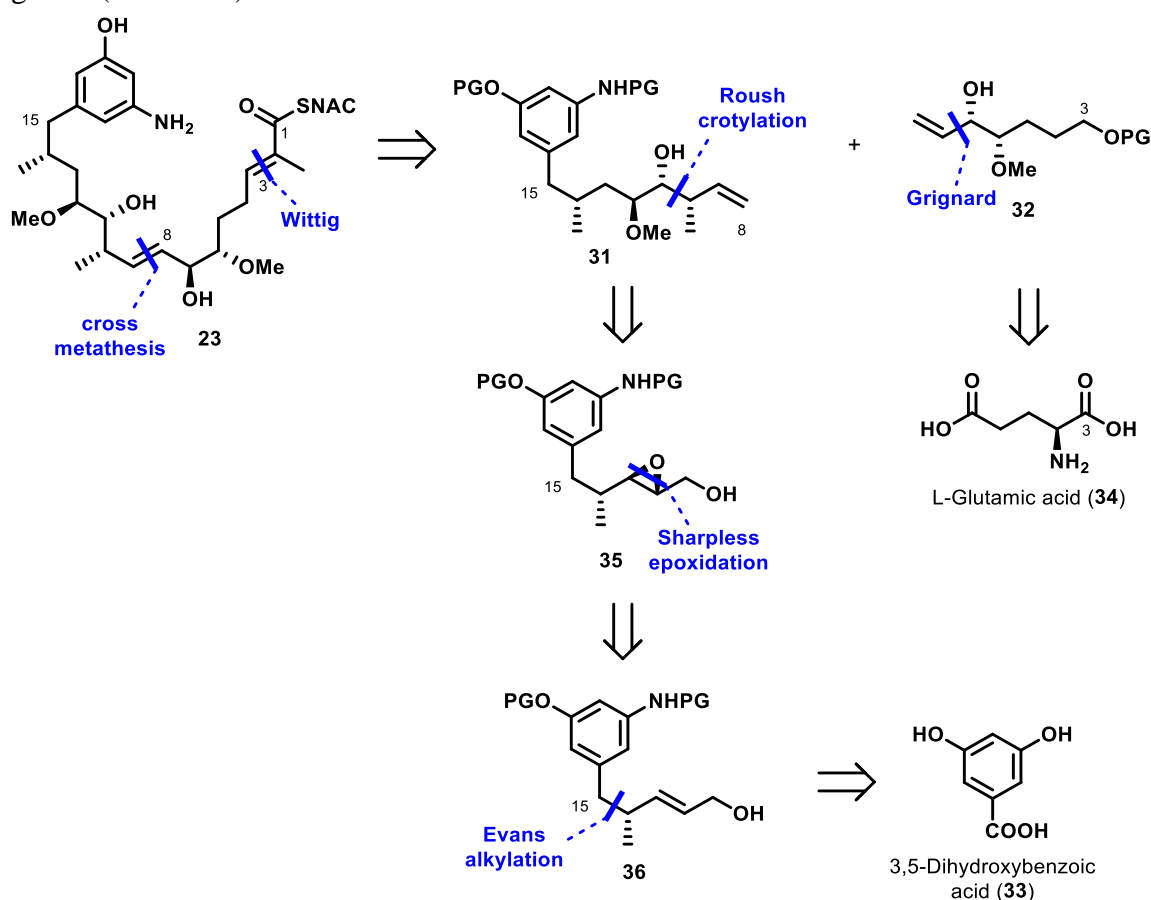

**Figure 5:** Desired *seco*-progeldanamycin SNAC ester (**30**).

## 3 Results and Discussion

### 3.1 Preliminary Works

First studies towards a simplified 8-desmethyl-*seco*-progeldanamycin SNAC ester **23** were carried out by Jekaterina Hermane in this group.<sup>[75]</sup> The approach, based in part on earlier work by Monika Vogt<sup>[78]</sup> and Sascha Ceylan<sup>[79]</sup>, includes a cross metathesis of western fragment **31** and eastern fragment **32** as key step. Both fragments could be synthesized from commercially available starting materials. 3,5-Dihydroxybenzoic acid (**33**) served as starting point for the synthesis of the western fragment and L-glutamic acid (**34**) for the eastern fragment (Scheme 8).



**Scheme 8:** Retrosynthetic approach towards 8-desmethyl-*seco*-progeldanamycin SNAC ester (**23**) as established by Hermane.<sup>[75]</sup>

In the case of Hermane's work, the synthesis started with benzylic alcohol **37** which was provided by Vogt. From there, 8-desmethyl-*seco*-progeldanamycin SNAC ester (**23**) was successfully synthesized over 21 steps (longest linear sequence) in 1.3% overall yield. This derivative was then applied in an enzyme assay with GdmF and successfully converted to the corresponding macrolactam 8-desmethyl-progeldanamycin (**24**), as confirmed by MS/MS fragmentation experiments (Scheme 9). This experiment proved that heterologously expressed GdmF is in principle able to accept complex substrates. Attempts to synthesize the natural *seco*-progeldanamycin SNAC ester, which has a methyl group at C-8, were carried out by

Ilona Bułyszko. However, the same cross metathesis strategy using the methyl branched eastern fragment **38** was not successful.<sup>[80]</sup>

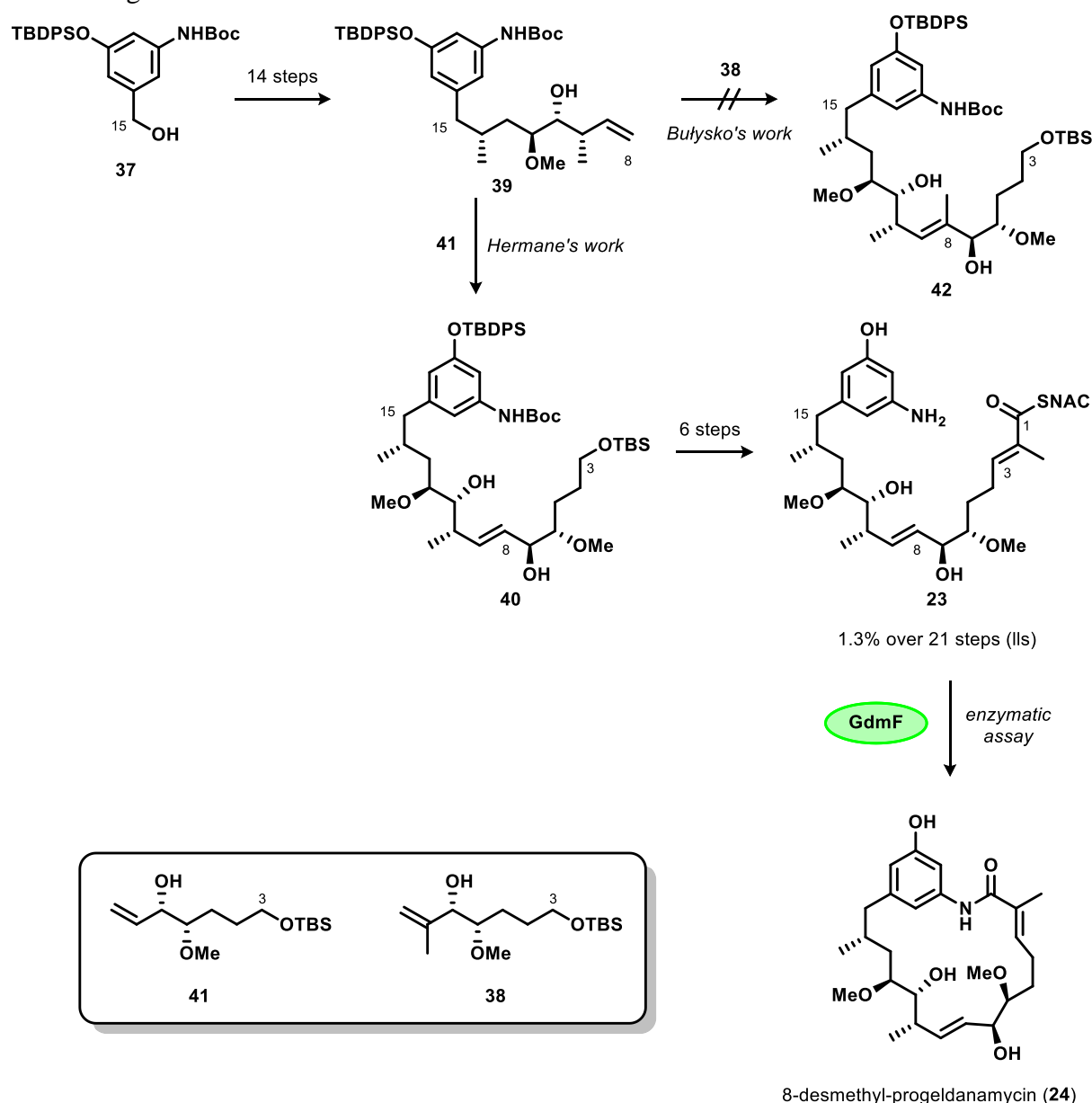

**Scheme 9:** Cross metathesis approaches by Hermene and Bułyszko and successful macrolactamisation of 8-desmethyl-*seco*-progeldanamycin SNAC ester (**23**) by heterologously expressed amide synthase GdmF. 8-Desmethyl-progeldanamycin (**24**) was detected by MS/MS fragmentation experiments. 11s = longest linear sequence.

## 3.2 First Generation Synthesis

### 3.2.1 Ring-Closing Metathesis

Bułyszko's work showed that cross metathesis is not feasible for the generation of the desired trisubstituted double bond in *seco*-progeldanamycin. However, ring-closing metathesis (RCM) is known as a powerful tool in natural product synthesis.<sup>[81]</sup> Temporarily introducing a tether would connect the two fragments and allow an RCM. Removing the tether would open the ring and allow the desired carbon chain to emerge. Inspired by Kobayashi's work<sup>[82]</sup> on the total synthesis of the antibiotic (+)-TMC-151C, silicon-tethered ring-closing metathesis



seemed to be a promising method to access the ene-1,5-diol motif (C-7 to C-11) in **43**. This approach would require aforementioned western fragment **39** and eastern fragment **38**, which could be synthesized following the route established by Hermane (Scheme 10).

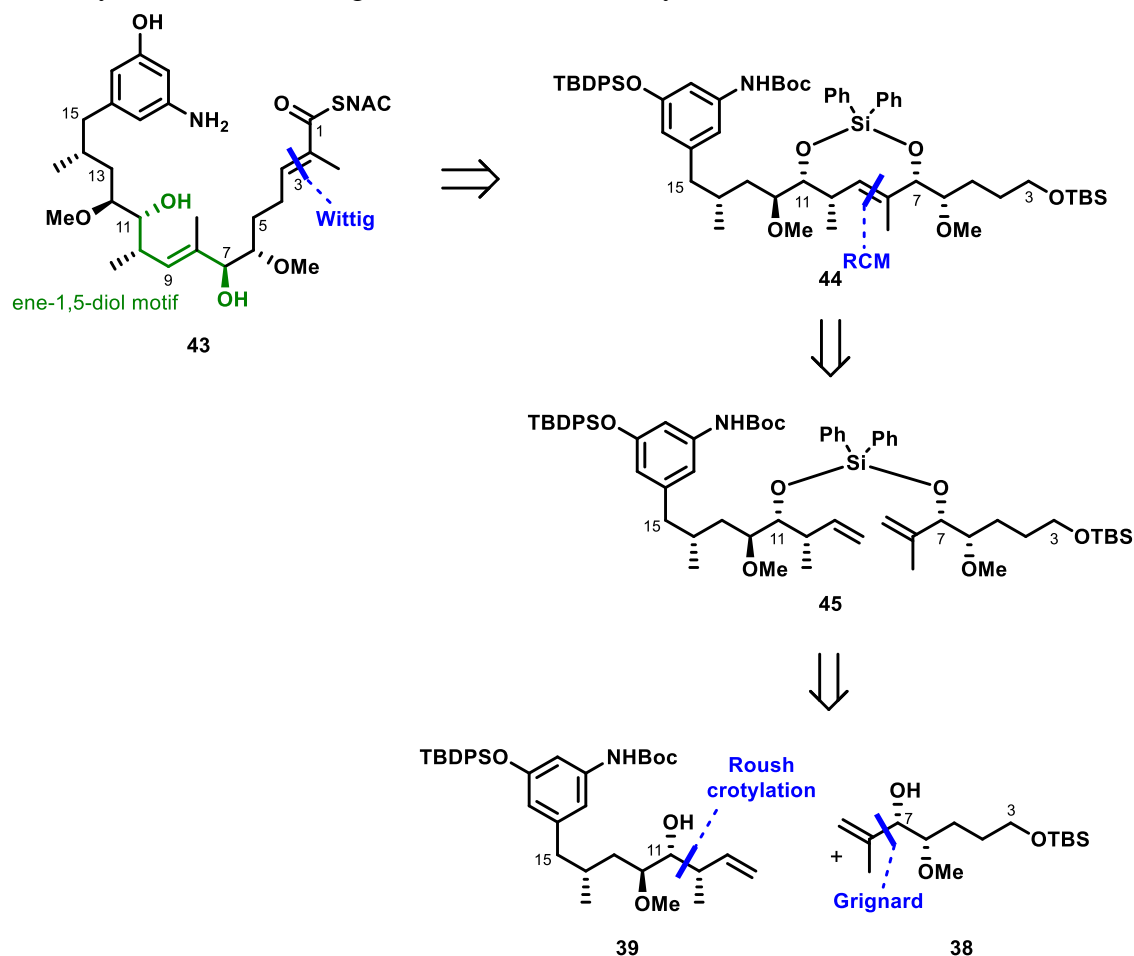

**Scheme 10:** Retrosynthetic analysis for the ring-closing metathesis (RCM) approach towards *seco*-progeldanamycin SNAC ester (**43**).

The homoallylic and the allylic alcohol in the two respective fragments are sought to be connected by the same silicon-tethering method that was used in Kobayashi's synthesis. The resulting silylene acetal could then be subjected to RCM.

### 3.2.1.1 Synthesis of Eastern Fragment **38**

Eastern fragment **38** was synthesized as described by Hermane, starting from the diazotization of L-glutamic acid (**34**) yielding lactone **46** (Scheme 11). Reduction of the carboxylic acid with borane dimethyl sulfide complex and protection of the resulting alcohol (**47**) as PMB ether proceeded in very good yields. In contrast to the previous reported procedure, the amount of 4-methoxybenzyl-2,2,2-trichloroacetimidate (**48**) used for the protection was reduced from 4.0 to 1.5 equivalents. This simplified the purification of the product. However, increasing the reaction time to 3 days was necessary to ensure complete consumption of the starting material. Lactone **49** was opened by reduction with LAH to give diol **50**. The selective silylation of the primary alcohol under standard conditions to furnish TBS ether **51** and the subsequent methylation of the secondary alcohol proceeded smoothly and in very good yields giving rise to **52**. The PMB group was then removed using DDQ in 96% yield

based on recovered starting material (brsm) to furnish primary alcohol **53**. Oxidation towards the corresponding aldehyde was first conducted with Dess-Martin periodinane (DMP) as described by Hermane. However, the yields were unsatisfactory. Oxidation under Swern conditions provided desired  $\alpha$ -chiral aldehyde **54** in a better yield of 85%. To avoid racemization of the  $\alpha$ -stereogenic center, the aldehyde was always prepared fresh for subsequent reactions. The last step towards desired eastern fragment **38** was a Grignard reaction. The addition of a vinyl Grignard reagent to an aldehyde provides a straightforward route to synthesize allylic alcohols. In the procedure published by Bułyszko, precooled *isopropenylmagnesium bromide* was added to a solution of aldehyde **54** in THF at  $-78\text{ }^{\circ}\text{C}$ , furnishing allylic alcohol **38** in 56% yield and a diastereoselectivity *d.r.* > 19:1.<sup>[80]</sup> Unfortunately, the results of this procedure were not reproducible as the diastereoselectivity did not exceed a ratio of 4:1. The yield could not be increased to more than 60%. At the time, the issue of stereoselectivity was not investigated further. However, at a later point in the studies, a superior method was established increasing the *d.r.* significantly. This will be discussed in detail in chapter 3.3.3. With the desired eastern fragment in hand, the synthesis of western fragment **39** came into focus.

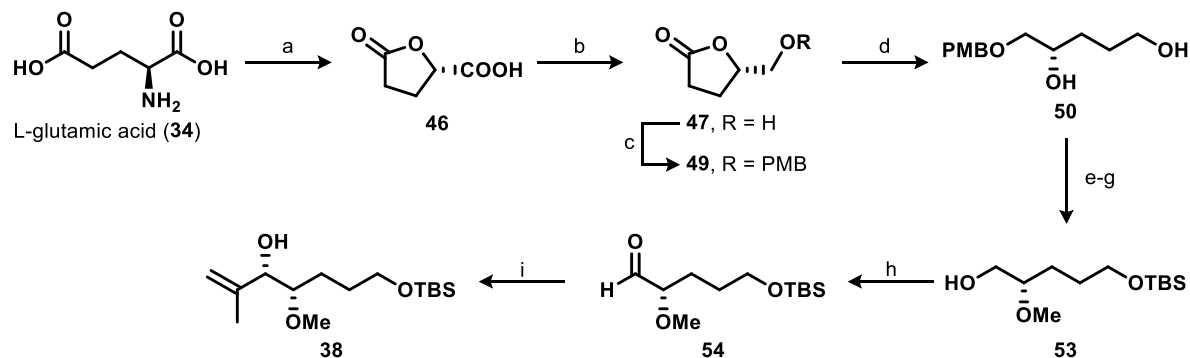

**Scheme 11:** Synthesis of eastern fragment **38**. Conditions: a)  $\text{NaNO}_2$ ,  $\text{HCl}$ ,  $\text{H}_2\text{O}$ ,  $0\text{ }^{\circ}\text{C}$  to rt, 18 h, 47%; b)  $\text{BH}_3\cdot\text{SMe}_2$ , THF,  $0\text{ }^{\circ}\text{C}$  to rt, 12 h, 92%; c) 4-Methoxybenzyl-2,2,2-trichloroacetimidate, CSA,  $\text{CH}_2\text{Cl}_2$ , rt, 3 d, 92%; d) LAH, THF,  $-10\text{ }^{\circ}\text{C}$ , 2 h, 91%; e) TBSCl, imidazole,  $\text{CH}_2\text{Cl}_2$ ,  $0\text{ }^{\circ}\text{C}$  to rt, 3 h, 89%; f) NaH, MeI, THF,  $0\text{ }^{\circ}\text{C}$  to rt, 6 h, 98%; g) DDQ,  $\text{CH}_2\text{Cl}_2/\text{pH7}$  phosphate buffer (9:1),  $0\text{ }^{\circ}\text{C}$  to rt, 5 h, 96% brsm; h)  $(\text{COCl})_2$ , DMSO,  $\text{CH}_2\text{Cl}_2$ ,  $-78\text{ }^{\circ}\text{C}$ , 15 min then **53**,  $-78\text{ }^{\circ}\text{C}$ , 1.5 h then  $\text{Et}_3\text{N}$ ,  $-78\text{ }^{\circ}\text{C}$  to rt, 85%; i) *isopropenylmagnesium bromide*, THF,  $-78\text{ }^{\circ}\text{C}$ , 30 min, 60%, *d.r.* = 4:1.

### 3.2.1.2 Synthesis of Western Fragment **39**

In a master thesis that preceded the present work, silyl ether **55** was synthesized according to the route established by Hermane. In the course of that work, no conditions for the removal of the TBS ether could be found. Unfortunately, the remaining amount of material was not sufficient to carry out further investigations at the beginning of the present work. Therefore, the synthesis of silyl ether **55** was repeated on large scale (0.27 mol). Furthermore, as the synthesis proved to be tedious and time consuming in the master thesis, efforts were made to reduce the number of reaction steps.

Starting from commercially available 3,5-dihydroxybenzoic acid (**33**), mono-amination with ammonium chloride and aqueous ammonia in an autoclave at  $180\text{ }^{\circ}\text{C}$  and subsequent Fischer esterification provided aniline **56** in good yields (Scheme 12). The Boc-protection of the aniline and the protection of the phenol as TBDPS ether were carried out following standard protocols. Reduction of the methyl ester using DIBAL-H in THF furnished the corresponding benzylic alcohol (**37**) in very good yields. According to Hermane's procedure the next step was the transformation of the alcohol into its bromide **57** in an Appel reaction followed by a

Finkelstein reaction to yield benzylic iodide **58** in 88% yield over 2 steps (depicted in grey in Scheme 12). However, the benzylic alcohol could be directly converted to its corresponding iodide in 90% yield in an Appel reaction with iodine, imidazole and triphenylphosphine. In addition, the benzylic iodide proved to be stable when stored at  $-25\text{ }^{\circ}\text{C}$ , so that the two-step sequence did not provide any advantage. Next, Evans alkylation using (*S*)-Evans auxiliary **59** gave rise to fragment **60** as a single diastereomer. Reductive removal of the auxiliary with  $\text{LiBH}_4$  provided alcohol **61** in 80% yield.

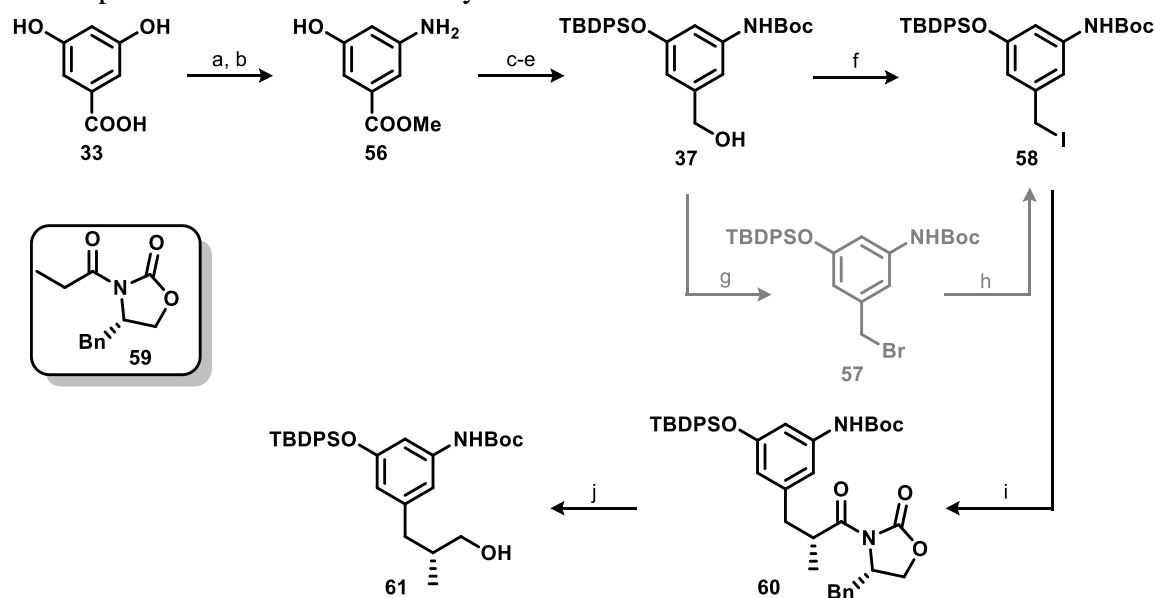

**Scheme 12:** Synthesis of alcohol **61**. Conditions: a)  $\text{NH}_4\text{Cl}$ ,  $\text{NH}_3$  (25%, aq.),  $180\text{ }^{\circ}\text{C}$ , autoclave, 40 h; b)  $\text{MeOH}$ ,  $\text{H}_2\text{SO}_4$  (conc.), reflux., 36 h, 69% o2s; c)  $\text{Boc}_2\text{O}$ ,  $\text{NaHCO}_3/\text{THF}$ , rt, 26 h, 90%; d)  $\text{TBDPS-Cl}$ , imidazole, DMAP,  $\text{CH}_2\text{Cl}_2$ ,  $35\text{ }^{\circ}\text{C}$ , 10 h, 84%; e)  $\text{DIBAL-H}$ ,  $\text{THF}$ ,  $-78\text{ }^{\circ}\text{C}$  to  $0\text{ }^{\circ}\text{C}$ , 4 h, 93%; f)  $\text{PPh}_3$ , imidazole,  $\text{I}_2$ ,  $\text{CH}_2\text{Cl}_2$ ,  $0\text{ }^{\circ}\text{C}$ , 4 h, 90%; g)  $\text{PPh}_3$ ,  $\text{CBr}_4$ ,  $\text{CH}_2\text{Cl}_2$ , rt, 45 min, 92%; h)  $\text{NaI}$ , acetone, rt, 2 h, 96%; i) **59**,  $\text{LDA}$ ,  $\text{THF}$ ,  $-78\text{ }^{\circ}\text{C}$ , 15 min then **58**,  $-78\text{ }^{\circ}\text{C}$  to  $-35\text{ }^{\circ}\text{C}$ , 2.5 h, 83%; j)  $\text{LiBH}_4$ ,  $\text{Et}_2\text{O}$ ,  $0\text{ }^{\circ}\text{C}$ , 3 h, 78%.

Following Hermans' route, a subsequent seven-step sequence would introduce the methoxy group at C-12. However, as shown in the master thesis, this approach was quite cumbersome and inefficient. Therefore, attempts were made to shorten the synthesis and introduce the methoxy group in a more direct way (Scheme 13). Encouraged by the successful alkylation introducing the methyl group at C-14, the methoxy group was sought to be introduced by an asymmetric enolate alkylation as well. The most common applications of this approach include amide-type auxiliaries, such as the oxazolidinone-type pioneered by Evans<sup>[83]</sup> or the pseudoephedrine-type developed by Myers<sup>[84]</sup>. These reagents undergo enolate alkylation with excellent degree of diastereoselectivity in the formation of  $\alpha$ -tertiary centers and found wide applications in total synthesis. After successful alkylation, the removal of the auxiliary would furnish  $\alpha$ -methoxy alcohol **62** in only two steps. The required (*R*)-Evans auxiliary **63** was synthesized from (*R*)-4-benzyloxazolidin-2-one and methoxyacetyl chloride. Alcohol **61** was transformed into iodide **64** under standard Appel conditions. Alkylation under the same conditions as described above did not result in product formation. Increasing the reaction temperature to room temperature did not affect this result. Therefore, the alkylation was investigated using Myers auxiliary **65** which was easily accessible from (–)-pseudoephedrine. After 18 h at  $-78\text{ }^{\circ}\text{C}$ , no reaction occurred as judged by TLC-analysis, instead, iodide **64** could be recovered in 92% yield. Increasing the reaction temperature to  $0\text{ }^{\circ}\text{C}$  resulted in partial Boc deprotection, but no product formation.

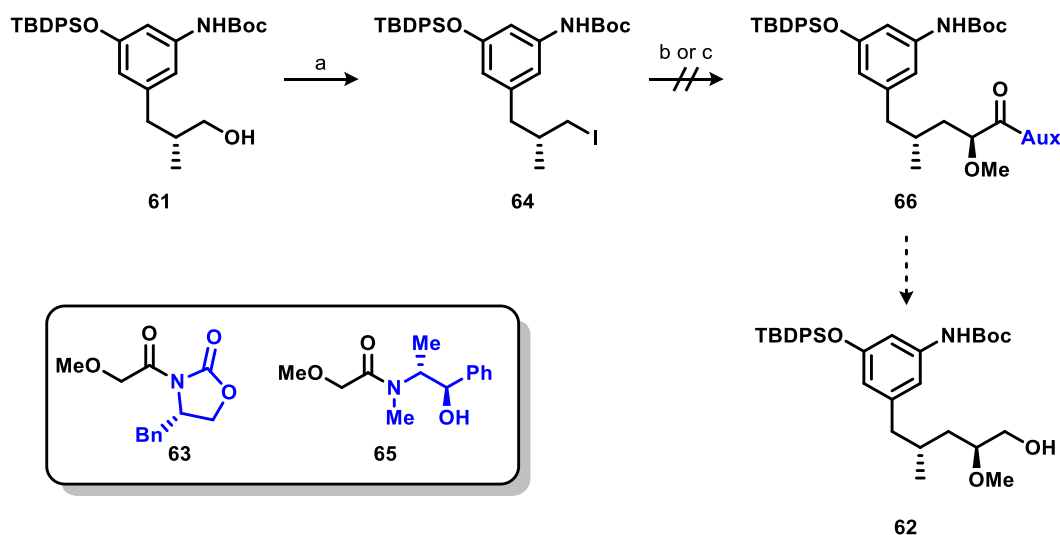

**Scheme 13:** Attempted asymmetric enolate alkylation towards  $\alpha$ -methoxy alcohol **62**. Conditions: a)  $\text{PPh}_3$ , imidazole,  $\text{I}_2$ ,  $\text{CH}_2\text{Cl}_2$ , rt, 2.5 h, 97%; b) **63**, LDA, THF,  $-78^\circ\text{C}$ , 15 min then **61**,  $-78^\circ\text{C}$  to  $-35^\circ\text{C}$ , 2.5 h; c) **65**, LiCl, LDA, THF,  $-78^\circ\text{C}$ , 1 h,  $0^\circ\text{C}$ , 15 min, rt, 5 min then **61**,  $-78^\circ\text{C}$ , 18 h.

Since the enolate alkylation strategy did not appear promising, the seven-step sequence mentioned at the beginning was pursued (Scheme 14, A). Oxidation of alcohol **61** with DMP and subsequent Wittig olefination with the stabilized ylene **67** yielded  $\alpha,\beta$ -unsaturated ester **68**, which was reduced with DIBAL-H furnishing allylic alcohol **69**. Unfortunately, the reduction of the ester only proceeded in moderate yields. The allylic alcohol was then subjected to an asymmetric Sharpless epoxidation using the improved protocol as developed in the preceding master thesis providing epoxide **70** in yields up to 93%. However, due to difficulties during workup the reported yields could not be reliably reproduced. After aqueous workup with 2 M NaOH, large quantities of titanium dioxide precipitated which had to be removed by filtration before chromatography. Titanium dioxide which appeared as a thick white slurry, tended to trap parts of the product. Treatment of the reaction mixture with 1.05 equivalents<sup>3</sup> of inexpensive EDTE (*N,N,N',N'*-tetrakis(2-hydroxyethyl)ethylenediamine) and stirring at  $55^\circ\text{C}$  for 15 minutes prior to workup proved beneficial by converting  $\text{Ti}(\text{O}i\text{-Pr})_4$  into a water-soluble and water-stable complex (Scheme 14, B).<sup>[85]</sup> After cooling to room temperature, dilution with water and simple extraction with EtOAc provided the epoxide in highest purity, making further purification steps by chromatography unnecessary. Furthermore, yields of 94-96% were reliably achieved with the improved workup procedure. The epoxide was then opened in a highly regioselective manner with DIBAL-H to give 1,2-diol **71** in full chemoselectivity in 70% yield. Mono-silylation of the primary alcohol using TBSOTf and subsequent methylation of the secondary alcohol with Meerwein's salt ( $\text{Me}_3\text{O}^+\text{BF}_4^-$ ) and proton-sponge<sup>®</sup> provided silyl ether **55**. It is worth mentioning, that the amount of  $\text{Me}_3\text{O}^+\text{BF}_4^-$  used should not exceed 2.5 equivalents, otherwise methylation of the protected aniline was observed.

<sup>3</sup> Relative to the amount of  $\text{Ti}(\text{O}i\text{-Pr})_4$ .

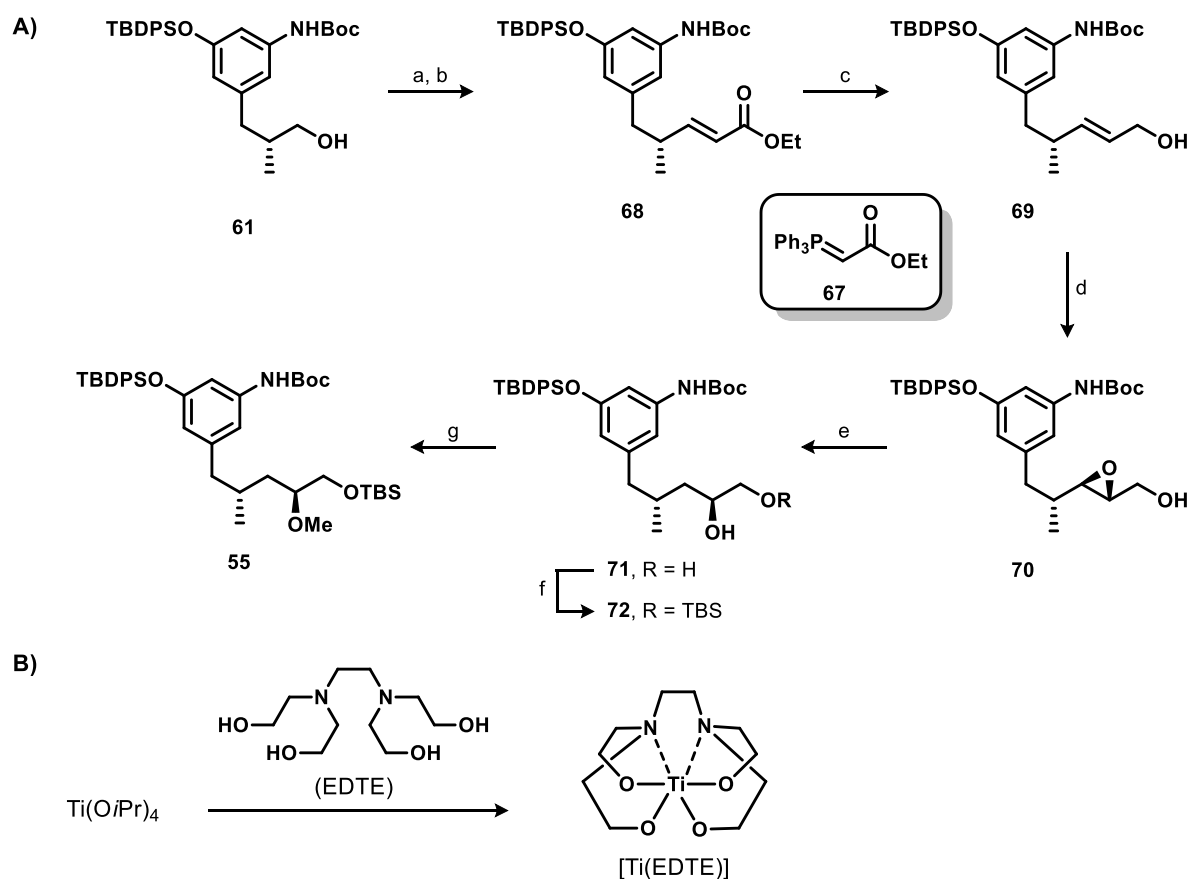

**Scheme 14:** **A)** Synthesis of **55**. Conditions: a) DMP, NaHCO<sub>3</sub>, CH<sub>2</sub>Cl<sub>2</sub>, 0 °C to rt, 30 min; b) **67**, CHCl<sub>3</sub>, 50 °C, 12 h, 80% o2s; c) DIBAL-H, CH<sub>2</sub>Cl<sub>2</sub>, -78 °C, 18 h, 65%; d) Ti(O*i*-Pr)<sub>4</sub>, *t*-BuOOH, D-(-)-DET, molecular sieves 4 Å, CH<sub>2</sub>Cl<sub>2</sub>, -20 °C, 42 h, 95%, *d.r.* = 10:1; e) DIBAL-H, Et<sub>2</sub>O, 0 °C, 4.5 h, 61%; f) 2,6-lutidine, TBSOTf, CH<sub>2</sub>Cl<sub>2</sub>, 0 °C, 30 min, 77%, 92% brsm; g) Proton-sponge<sup>®</sup>, Me<sub>3</sub>O<sup>+</sup>BF<sub>4</sub><sup>-</sup>, CH<sub>2</sub>Cl<sub>2</sub>, rt, 1 h, 85%. **B)** Complexation of Ti(O*i*-Pr)<sub>4</sub> by EDTE, forming a water-soluble and water-stable complex.

With silyl ether **55** now available in sufficient quantity, conditions for the deprotection of the primary alcohol could be investigated. Although the initial attempts in the master thesis on TBS cleavage using LiBF<sub>4</sub> failed, this method was revised as it is a viable alternative to TBAF or acid hydrolysis conditions, which proved ineffective since decomposition of the starting material was observed. In TBAF-mediated desilylations, the trace amount of water in the reaction was found to have a direct influence on the efficacy of the reagent.<sup>[86]</sup> With increasing amounts of water, the reactivity of TBAF was hampered. The same effect can probably occur when LiBF<sub>4</sub> is used, and residual water could be the reason why the deprotection worked so poorly. Hence, LiBF<sub>4</sub> was dried under vacuum for 2 h at 155 °C, which is considered as suitable drying temperature to remove adsorbed water without the risk of thermal decomposition.<sup>[87]</sup> Indeed, using dried LiBF<sub>4</sub> in dry MeCN/CH<sub>2</sub>Cl<sub>2</sub> at room temperature did yield to the primary alcohol in good yields (88% brsm) after 48 h (Scheme 15). However, neither increasing the temperature nor the amount of LiBF<sub>4</sub> did result in complete consumption of the starting material. Dried LiBF<sub>4</sub> could be stored in a glovebox without any loss of reactivity, so that re-drying before use is not necessary. DMP oxidation of the alcohol forged aldehyde **73**, which served as the substrate for a stereoselective Roush crotylation as it was described for the total synthesis of reblistin.<sup>[88]</sup>

For crotylation, (*S,S*)-diisopropyl (*Z*)-crotylboronate (**74**) was freshly prepared from (*Z*)-crotylboronate diethanolamine complex (**76**) as needed (Scheme 15, B). The diethanolamine

complex in turn was prepared from *cis*-butene. Treatment of *cis*-butene with KO*t*-Bu and *n*-BuLi and subsequent addition of B(O*i*-Pr)<sub>3</sub> provided the boronic acid to which diethanolamine was added forming the complex. The (*S,S*)-diisopropyl (*Z*)-crotylboronate could also have been furnished directly by treating the boronic acid with diisopropyl tartrate, but the detour has a major advantage over the direct route. Recrystallisation of diethanolamine complex **76** increases its isomeric purity (up to >99.8%), whereas reported purities for the direct route are lower ( $\geq 99\%$ ).<sup>[89]</sup>

The crotylation of aldehyde **73** proceeded in excellent yield with high diastereoselectivity providing homoallylic alcohol **39** (Scheme 15, A). The undesired diastereomer could be removed by column chromatography. The western fragment was thus synthesized in 4.0% yield over 18 steps (longest linear sequence).

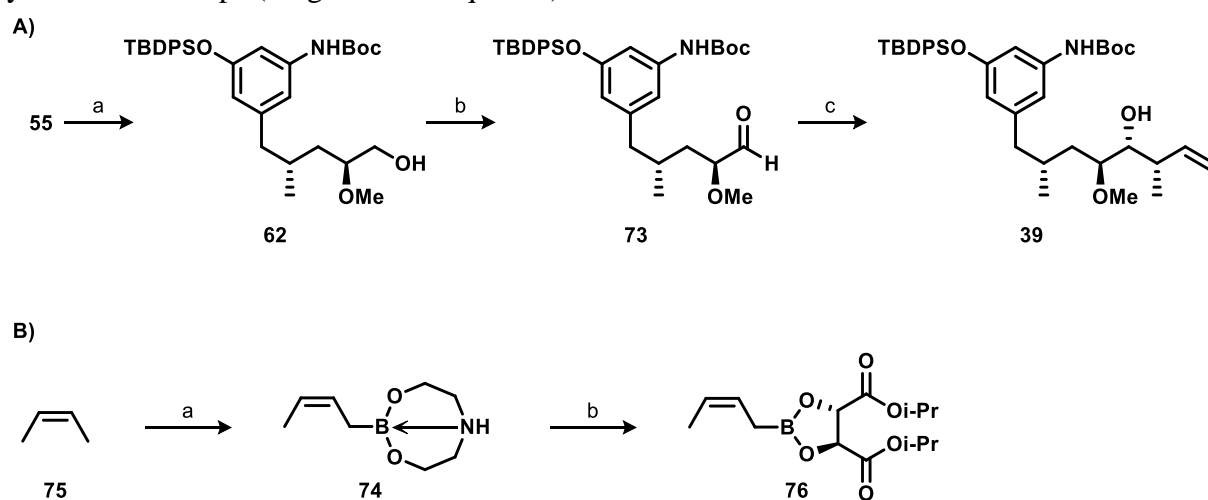

**Scheme 15:** A) Synthesis of western fragment **39**. Conditions: a) LiBF<sub>4</sub>, CH<sub>2</sub>Cl<sub>2</sub>/MeCN (1:1), rt, 48 h, 74%, 88% brsm; b) DMP, NaHCO<sub>3</sub>, CH<sub>2</sub>Cl<sub>2</sub>, 0 °C to rt, 1 h, 78%; c) (*Z*)-crotylboronate (**74**), molecular sieves 4 Å, toluene, -78 °C, 24 h, 96%, *d.r.* = 8:1. B) Synthesis of (*S,S*)-diisopropyl (*Z*)-crotylboronate (**74**). Conditions: a) KO*t*-Bu, *n*-BuLi, THF, -78 °C to -25 °C, 2 h, then triisopropyl borate, -78 °C, 30 min, then molecular sieves 4 Å, diethanolamine, rt, 2 h, 66%; b) (*S,S*)-diisopropyl tartrate, Et<sub>2</sub>O, rt, 10 min, 91%.

### 3.2.1.3 Tethering and RCM

With both, eastern **38** and western fragment **39** in hand, the envisaged silicon-tethered RCM could be investigated. Initial experiments were carried out using the silicon-tethering method described by Matsui *et al.* with Et<sub>2</sub>NPh<sub>2</sub>SiCl/Et<sub>3</sub>N/DMAP.<sup>[82,90]</sup> In their work, allylic alcohol **77** was treated with Et<sub>2</sub>NPh<sub>2</sub>SiCl in the presence of Et<sub>3</sub>N and a catalytic amount of DMAP furnishing intermediate **78** (Scheme 16). Subsequent addition of homoallylic alcohol **79** did yield silylene acetal **80** and RCM gave rise to **81**. This method requires that the alcohol to which the tether is first attached is used in excess (1.5 eq.) to ensure complete silylation of the second alcohol, to furnish the desired silylene acetal in good yields. Here, eastern fragment **38** was chosen to be used in excess since its synthesis was less elaborate than the synthesis of the western fragment. The desired tether **82** was readily accessible from dichlorodiphenylsilane (**83**).

Matsui's work:

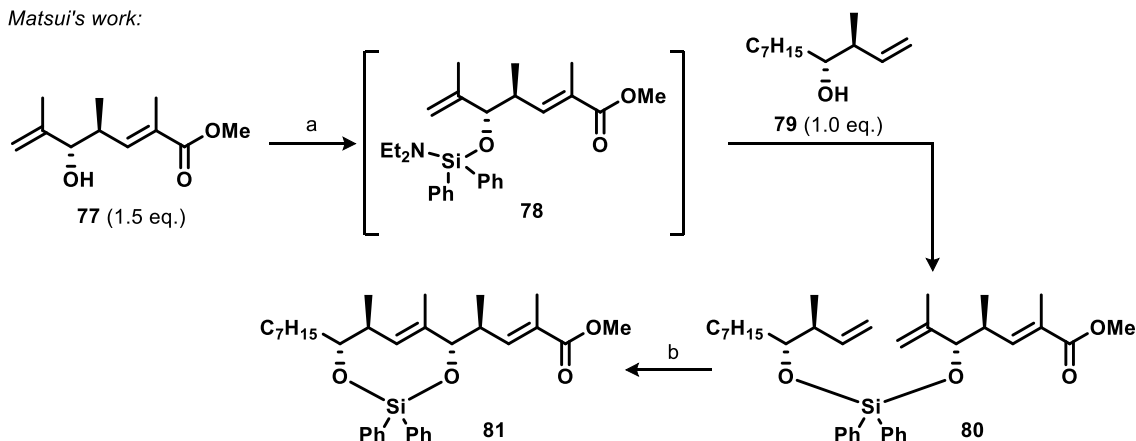

This work:

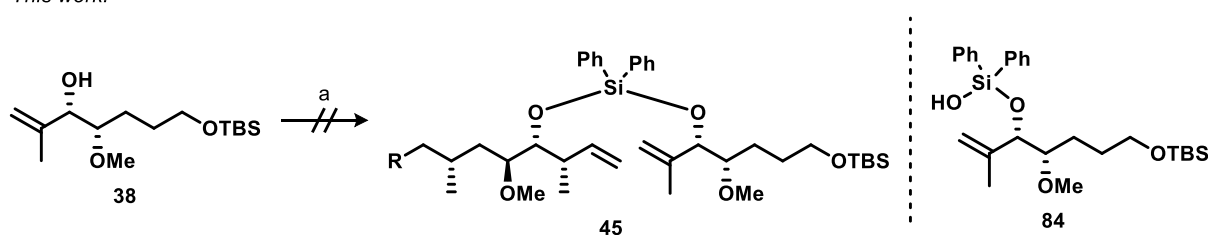

Tether:

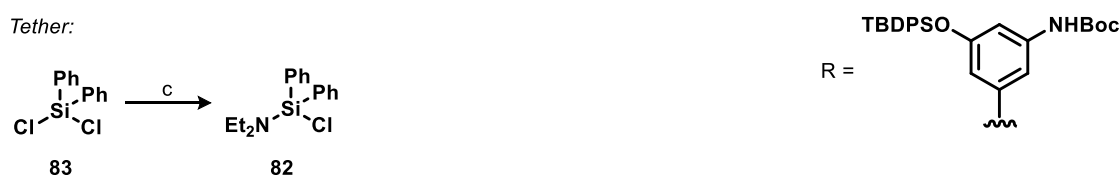

**Scheme 16:** RCM developed by Matsui *et al.* and attempted application of these conditions for RCM of eastern fragment **38** and western fragment **39**. Conditions: a)  $\text{Et}_2\text{NPh}_2\text{SiCl}$  (**82**),  $\text{Et}_3\text{N}$ , DMAP,  $\text{CH}_2\text{Cl}_2$ ,  $0^\circ\text{C}$ , 2 h, then **79** or **39**, DMAP,  $0^\circ\text{C}$ , 21 h, 85% for **80**; b) Hoveyda-Grubbs 2<sup>nd</sup> gen. catalyst, *p*-benzoquinone, xylene, reflux. 24 h, 93%, *E/Z*>20:1; c)  $\text{Et}_3\text{N}$ ,  $\text{Et}_2\text{NH}$ , THF, rt, 5 h, 57%.

Following the aforementioned methodology, eastern fragment **38** was accordingly treated with  $\text{Et}_2\text{NPh}_2\text{SiCl}$ ,  $\text{Et}_3\text{N}$  and DMAP. Although the tether was used in two-fold excess, complete consumption of the starting material could not be achieved after 5 h at  $0^\circ\text{C}$  as judged by TLC-analysis. Nevertheless, the reaction sequence was pursued further and western fragment **39** was added to the reaction. Unfortunately, after stirring overnight at  $0^\circ\text{C}$  formation of silylene acetal **45** did not occur. Instead, after aqueous workup, the eastern and western fragments could be re-isolated together with silyl ether **84** corresponding to the hydrolyzed intermediate silyl ether. Increasing the temperature after the addition of the second alcohol to room temperature or  $40^\circ\text{C}$  also did not result in silylene acetal formation.

With a tether of supposedly higher reactivity,  $(t\text{-Bu})_2\text{Si}(\text{OTf})_2$ , silylation of the eastern fragment did not occur at all. By using  $(i\text{-Pr})_2\text{Si}(\text{Cl})_2$  in excess (5.0 eq.) with imidazole complete silylation of the eastern fragment was achieved. Kugelrohr distillation was required to remove excess of the tether and to obtain pure silyl ether **85** in 88% yield. The subsequent tethering with the western fragment remained again unsuccessful even at elevated temperatures (Scheme 17).

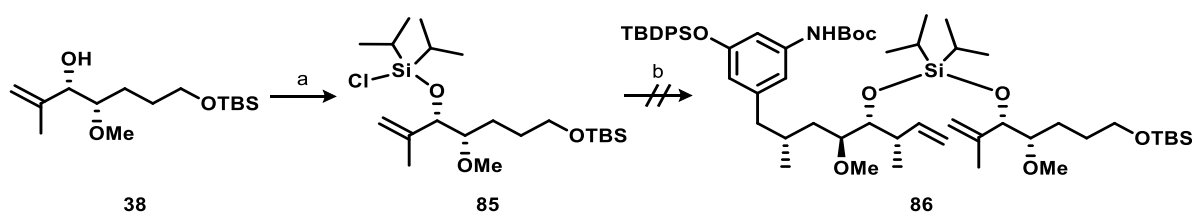

**Scheme 17:** Attempted tethering of eastern fragment **38** and western fragment **39** using  $(i\text{-Pr})_2\text{Si}(\text{Cl})_2$ . Conditions: a)  $(i\text{-Pr})_2\text{Si}(\text{Cl})_2$ , imidazole,  $\text{CH}_2\text{Cl}_2$ ,  $0\text{ }^\circ\text{C}$  to rt, 12 h, 88%; b) DMAP,  $40\text{ }^\circ\text{C}$ , 21 h.

Since the homoallylic alcohol of the western fragment appeared quite unreactive, it was considered to install the tether under the same conditions as for the successful installation on the eastern fragment. Yet again, silylation did not occur. As steric hindrance could additionally be responsible for the failed installation of the silicon-tethers, using a different less sterically demanding tether was envisaged. Choosing a tether that also increases the chain length between the two respective alcohols when connected, could also be beneficial. The introduction of the tether was now envisaged by esterification. Based on these considerations, phthaloyl chloride and succinyl chloride seemed to be suitable candidates. Simple esterification of the homoallylic alcohol of the western fragment with these very linkers promoted by  $\text{Et}_3\text{N}$  and DMAP were unsuccessful (Scheme 18).

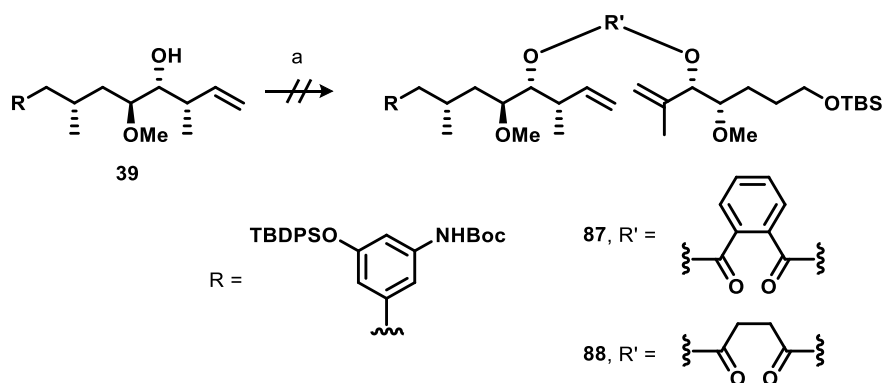

**Scheme 18:** Attempted tethering by esterification with phthaloyl chloride or succinyl chloride. Conditions: a) acid chloride,  $\text{Et}_3\text{N}$ , DMAP,  $\text{CH}_2\text{Cl}_2$ ,  $0\text{ }^\circ\text{C}$  to rt, then **38**,  $\text{Et}_3\text{N}$ , DMAP,  $0\text{ }^\circ\text{C}$  to rt, o/n.

Another powerful method for esterification, especially of sterically demanding alcohols, is the Steglich esterification. In this reaction a carboxylic acid is coupled with an alcohol under mild conditions using DCC and DMAP. In this context, the addition of succinic anhydride and DMAP to the eastern fragment yielded acid **89**. The ensuing Steglich esterification of acid **89** and western fragment **39** did then finally forge the desired tethered diene **90**, albeit in very low yield. Another disadvantage was that homoallyl alcohol **39** was not completely consumed in the reaction and could hardly be separated from the product. For the subsequent ring-closing metathesis various catalyst were examined, but no conditions were found that gave rise to the trisubstituted double bond in **91** (Scheme 19).

Due to the great difficulties installing the tether to the western fragment further investigations for the RCM did not seem reasonable and a different approach was developed.



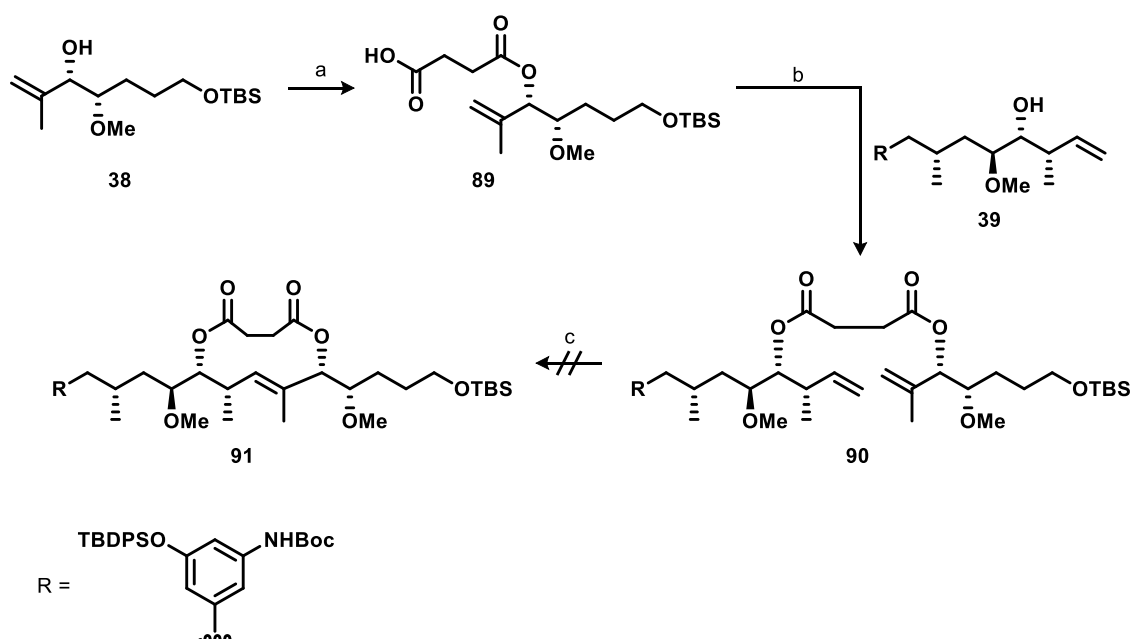

Catalysts applied in RCM:

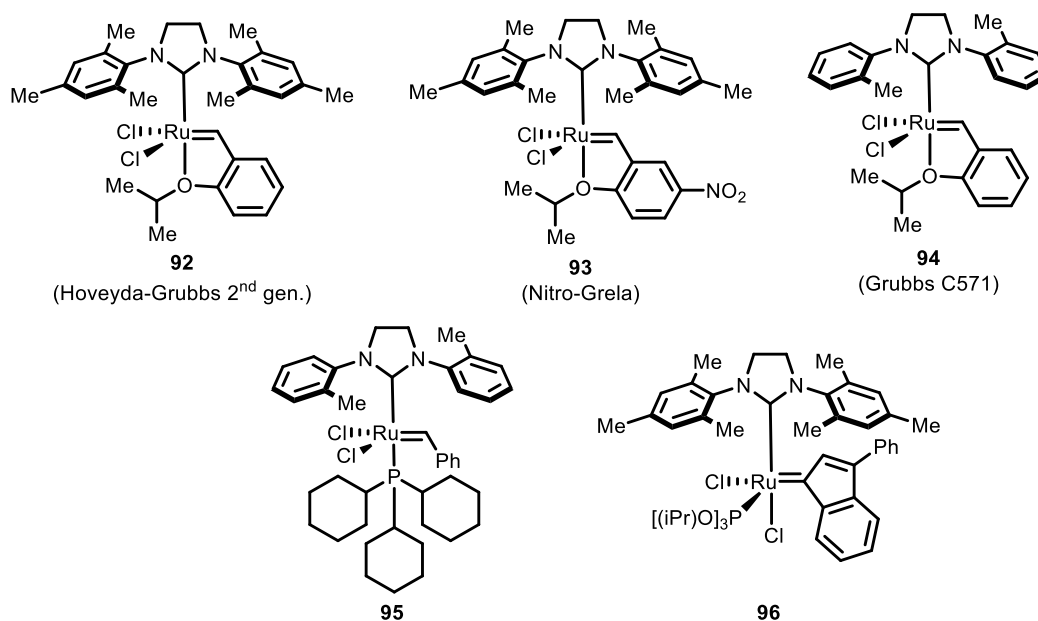

**Scheme 19:** Tethering of eastern fragment **38** and western fragment **39** via Steglich esterification and unsuccessful RCM. For the attempted RCM the ruthenium catalysts shown at the bottom were used. Conditions: a) succinic anhydride, DMAP,  $\text{CH}_2\text{Cl}_2$ , rt, 72 h, 97%; b) DCC, DMAP, **39**,  $\text{CH}_2\text{Cl}_2$ , rt, 18 h, 21%; c) ruthenium catalyst (**92–96**),  $\text{CH}_2\text{Cl}_2$ , 40 °C, 18 h.

### 3.2.2 Transition Metal-Mediated Coupling

For the new strategy, a transition metal-mediated coupling of iodide **97** with aldehyde **54** was envisaged (Scheme 20). The vinyl iodide could be furnished from alkyne **98** which in turn could be synthesized from aldehyde **73** in an *anti,syn*-selective Marshall propargylation. The Marshall propargylation, that is, the addition of a chiral metal-allenyl-species to an aldehyde, displays a very versatile method for the synthesis of homopropargylic alcohols. This powerful

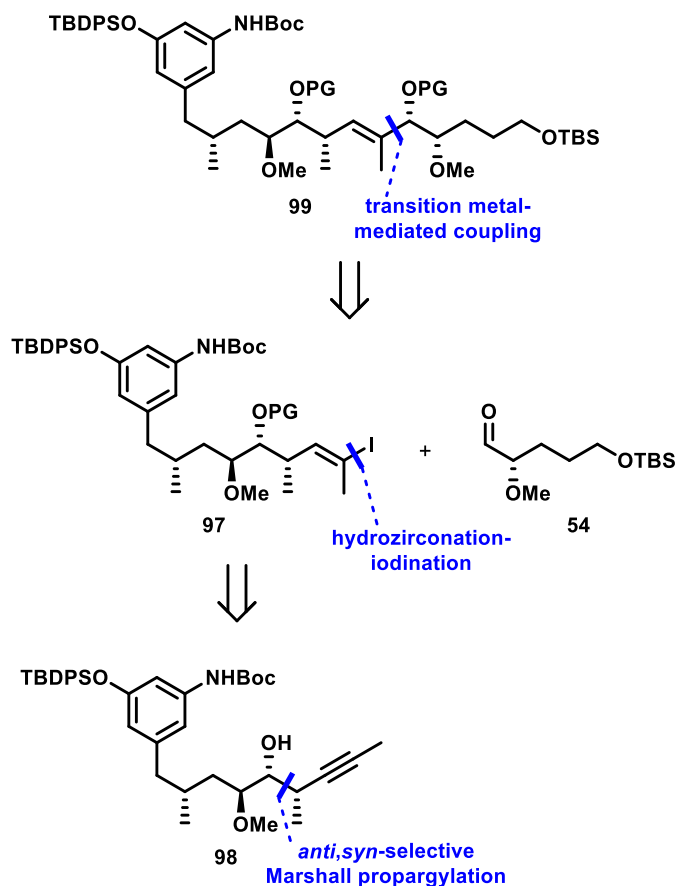

**Scheme 20:** Retrosynthetic analysis for transition metal-mediated coupling approach. PG = undefined protection group.

approach allows the generation of two new stereogenic centers with very high stereocontrol.<sup>[91,92]</sup> Various allenic organometallic compounds, consisting of tin, silicon, zinc, and indium, have been successfully applied in natural product synthesis over the past century.<sup>[93,94]</sup> Depending on the metal source used, the resulting stereoselectivity can be altered. For *anti,syn*-selective propargylations the choice of the allenyl species is rather limited and allenyl stannanes are the reagents of choice.<sup>[95–97]</sup> Here, allenylstannane **100** is to be used for the propargylation. With  $\text{BF}_3 \cdot \text{OEt}_2$  as non-chelating Lewis acid, the expected *anti,syn*-selectivity can be reconciled by the Cornforth transition state **101** as depicted in Scheme 21, while a Felkin-Anh orientation (**102**) would serve equally well.

The required allenylstannane **100** was prepared in a five-step sequence commencing with 1,2-dibromopropane (**103**) as published by Gribble *et al.* (Scheme 22).<sup>[98]</sup> Within this sequence, the Noyori reduction of the intermediate propargylic ketone **105** gave a single enantiomer of propargylic alcohol **106** and determined the stereochemistry of the later allene. After mesylation a copper-mediated  $\text{S}_{\text{N}}2'$  displacement gave rise to the allenylstannane. Here, the quality of the Cu(I) reagent was of great importance. A brief screening of different  $\text{CuBr} \cdot \text{SMe}_2$  batches revealed that the degree of oxidation of Cu(I) to Cu(II) seems to be more crucial than the purity. Batches with a purity of 98–99% gave excellent results as long as the reagent was handled carefully and under oxygen-free conditions. As soon as the storage vessel was exposed to air, yield losses occurred.

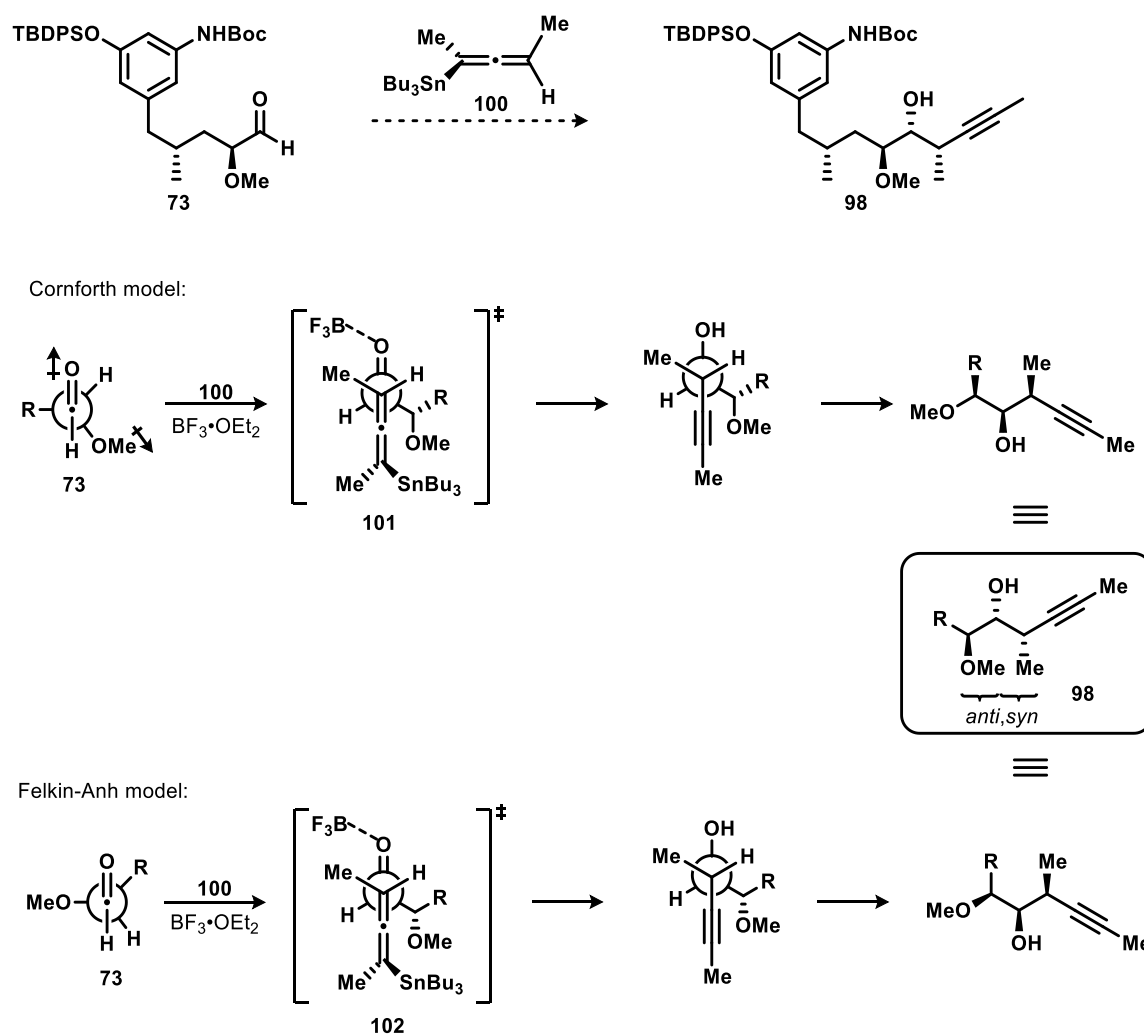

**Scheme 21:** Stereocontrol for the *anti,syn*-selective Marshall propargylation of allenylstannane **100** and aldehyde **73**.

With the allenylstannane in hand, the subsequent addition to aldehyde **73** catalyzed by  $\text{BF}_3 \cdot \text{OEt}_2$  was examined (Scheme 23). After optimization of the conditions, the desired alkyne **98** was obtained in only acceptable yields and mediocre diastereoselectivity (*d.r.* = 4:1 at C-11). The diastereomers were hardly separable at this stage. A by-product which was identified as allene **108** could be removed, however, undefined stannane impurities could not be completely removed even after multiple column chromatographies.

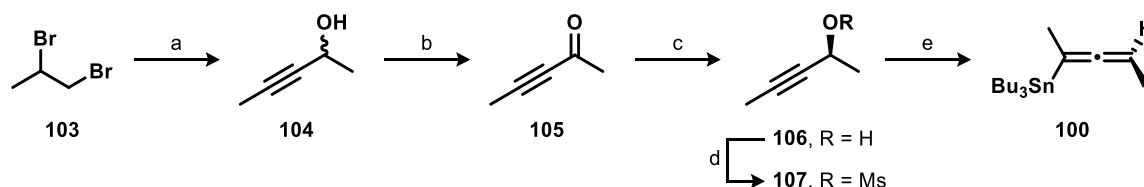

**Scheme 22:** Synthesis of allenylstannane **100**.<sup>[98]</sup> Conditions: a) DIPA, *n*-BuLi,  $-78^\circ\text{C}$  to  $0^\circ\text{C}$ , 30 min, THF, then **103**,  $-78^\circ\text{C}$ , 5 min, then acetaldehyde,  $-78^\circ\text{C}$ , 30 min, 71%; b)  $\text{MnO}_2$ ,  $\text{CH}_2\text{Cl}_2$ , rt, 24 h; c) (*S,S*)-Noyori catalyst, *i*-PrOH, rt, 18 h, 33% o2s; d)  $\text{Et}_3\text{N}$ , MsCl,  $\text{CH}_2\text{Cl}_2$ ,  $-78^\circ\text{C}$ , 1 h; e) DIPA, *n*-BuLi,  $-78^\circ\text{C}$  to  $0^\circ\text{C}$ , 30 min, THF, then  $\text{HSnBu}_3$ ,  $0^\circ\text{C}$ , 30 min, then  $\text{CuBr} \cdot \text{SMe}_2$ ,  $-50^\circ\text{C}$ , 30 min, then **107**,  $-50^\circ\text{C}$  to  $-10^\circ\text{C}$ , 1.5 h, 74% o2s.

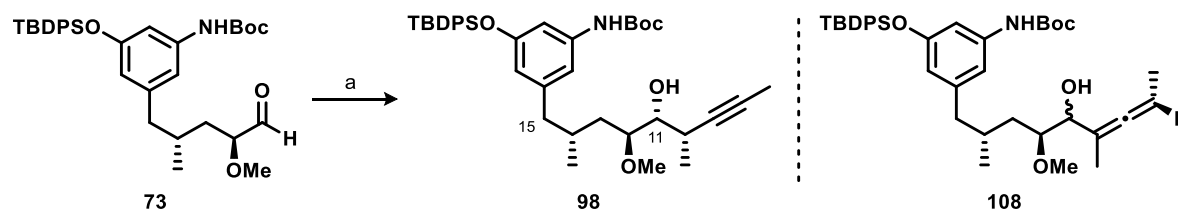

**Scheme 23:** *Anti,syn*-selective Marshall propargylation. Conditions: a) **100**,  $\text{BF}_3 \cdot \text{OEt}_2$ , molecular sieves 4 Å,  $\text{CH}_2\text{Cl}_2$ ,  $-78^\circ\text{C}$ , 4 h, 22%, *d.r.* = 4:1 at C-11.

Fortunately, a clean sample of the major diastereomer could be obtained in sufficient amount to determine the absolute configuration of the secondary alcohol by the Mosher ester methodology.<sup>[99]</sup> For this purpose, two diastereomeric compounds **109** were prepared from alkyne **98**, each by reaction with enantiomerically pure Mosher acid chloride (MTPA-Cl, **110**) (Scheme 24).

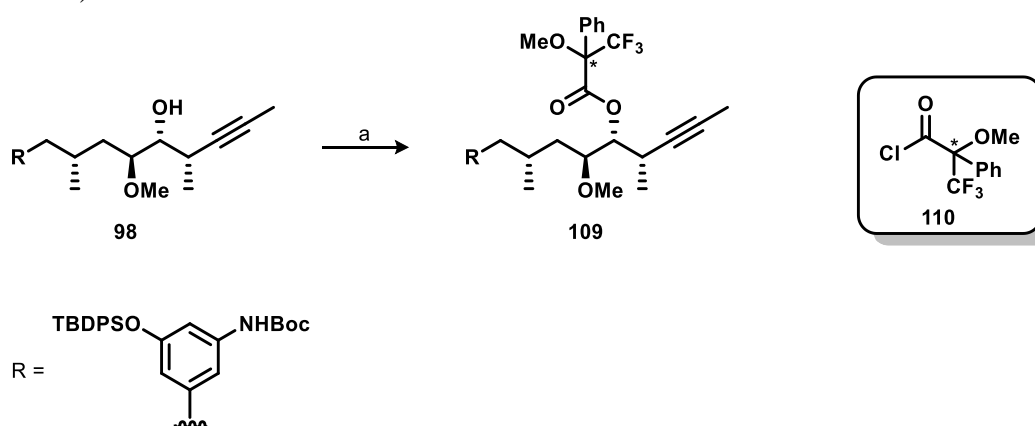

**Scheme 24:** Esterification furnishing Mosher ester **109**. Conditions: a) (*R*)- or (*S*)-**110**, DMAP,  $\text{Et}_3\text{N}$ ,  $\text{CH}_2\text{Cl}_2$ , rt, 18 h, 33% brsm for (*S*)-**109**, 38% brsm for (*R*)-**109**.

It is important to note, that when using the MTPA acid chloride for ester formation, the change in the relative priority of two of the groups must be considered. That is, the trifluoromethyl group ( $\text{CF}_3$ ) has a higher priority than the carboxyl group ( $\text{COOH}$ ), when the MTPA acid (MTPA-OH) is used, but lower than the chlorocarbonyl group ( $\text{COCl}$ ) when the MTPA acid chloride (MTPA-Cl) is used. As a result, the (*R*)-Mosher acid gives rise to the (*S*)-Mosher acid chloride and *vice versa*. The same applies for the ester formation. The (*R*)-Mosher acid furnishes the (*R*)-Mosher ester, while the (*R*)-Mosher acid chloride gives rise to the (*S*)-Mosher ester. Due to stereoelectronic effects, the Mosher esters adopt a preferred conformation (Figure 6). In the preferred conformation, the ester adopts a *s-trans* arrangement about its O–CO bond. Both, the trifluoromethyl substituent of the MTPA moiety and the methine proton of the secondary alcohol moiety are *syn*-coplanar ( $0^\circ$  dihedral angle) with the carbonyl group. In the respective conformations, the chemical shift of the  $^1\text{H}$ -NMR signals of the protons facing the phenyl ring varies due to the aromatic ring current that the phenyl ring exerts on these protons. By calculating the difference in the chemical shift  $\delta$  of the (*S*)- and (*R*)-ester ( $\Delta\delta^{\text{SR}} = \delta(\text{S-MTPA ester}) - \delta(\text{R-MTPA ester})$ ), the absolute configuration can be determined. Here, the desired (*R*)-configured alcohol in **98** could be verified.<sup>4</sup>

<sup>4</sup> Detailed information on the evaluation can be found in the experimental part on page 178.

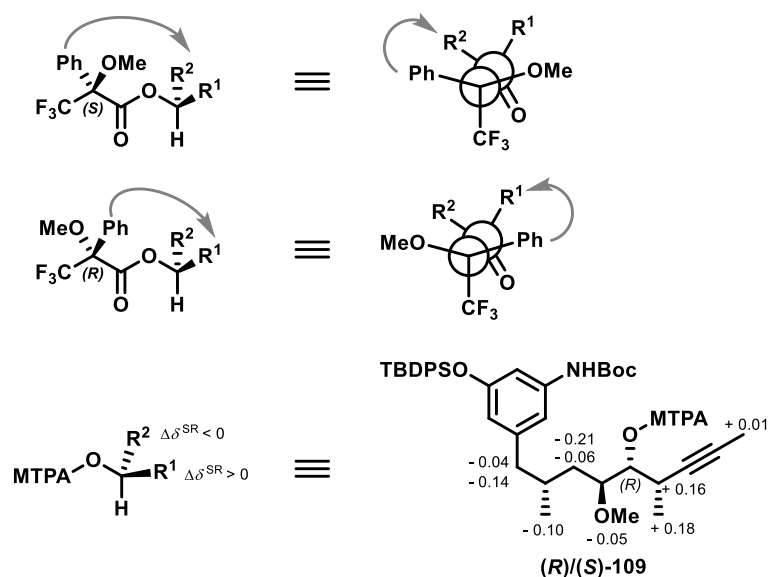

**Figure 6:** Preferred conformations of the Mosher esters. The grey arrows indicate the shielding effect emanating from the phenyl group. The difference in the chemical shift  $\delta$  is calculated according to  $\Delta\delta^{SR} = \delta(S) - \delta(R)$ , thus determining the absolute configuration of **98**.

Next, a hydrozirconation with the Schwartz reagent followed by metal halogen exchange with iodine should furnish (*E*)-configured vinyl iodide **97** but instead a mixture of two regioisomers **97** and **111** and (*Z*)-alkene **112** was obtained (Scheme 25, A). It was suggested that the free homopropargylic alcohol could coordinate the zirconium ion forming a five-membered intermediate. Indeed, this was demonstrated in a study by Liu and Ready. They found that the hydroxyl group of homopropargylic alcohols (**113**) is able to direct the zirconium species to the undesired carbon atom of the alkyne via a five-membered chelate intermediate (**115**, Scheme 25, B).<sup>[100]</sup>

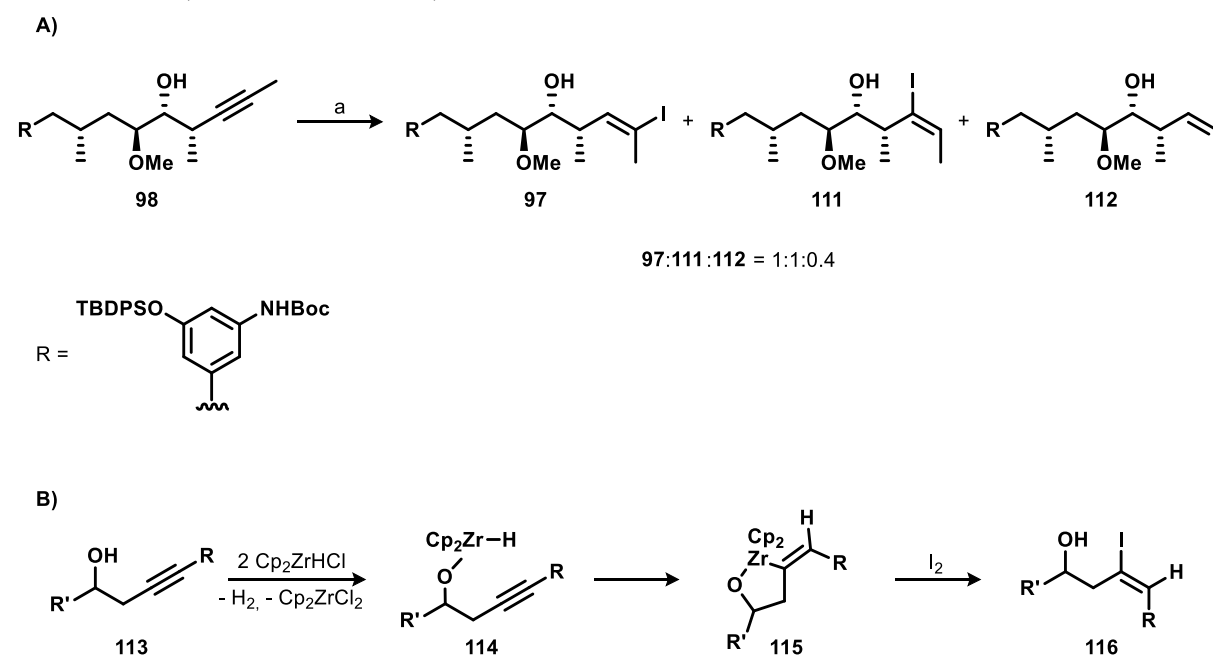

**Scheme 25:** A) Attempted hydrozirconation-iodination of alkyne **98**. Conditions: a)  $\text{Cp}_2\text{ZrHCl}$ , THF, 55 °C, 1 h, then  $\text{I}_2$ , 0 °C, 1 h. B) Directed hydrozirconation by homopropargylic alcohols.<sup>[100]</sup>

To suppress the formation of this five-membered chelate, the alcohol should be protected prior to hydrozirconation. This turned out to be quite problematic, as the homopropargylic alcohol was comparatively unreactive (Scheme 26). Numerous attempts to protect the alcohol with different silyl protection groups failed (entries 1 to 6). Even under rather harsh conditions using the silylating agent bis(trimethylsilyl)acetamide (BSA) which is commonly used in silylations to increase the volatility of substrates for gas chromatography analysis, did not provide the protected alcohol (entry 7). The formation of the corresponding PMB ether and MOM ether was also unsuccessful (entries 8 and 9), as was the attempt to form the acetate (entry 10). At this point, the first generation synthesis was discontinued. One of the major disadvantages of this first approach is the pronounced linearity of the synthesis. Due to the large number of steps and the low overall yield in the preparation of alkyne **98** (1% over 18 steps, longest linear sequence), the route was very laborious. In addition, it was not possible to prepare sufficient quantities of material to evaluate more conditions for the protection of the unreactive homopropargylic alcohol. More importantly, this prevented the investigation of conditions for the formation of the pent-2-ene-1,5-diol motif. Furthermore, the free proton at the Boc-protected aniline prohibits the use of strategies based carbanion chemistry for the generation of this very motif. Thus, a second generation synthesis approach was developed.

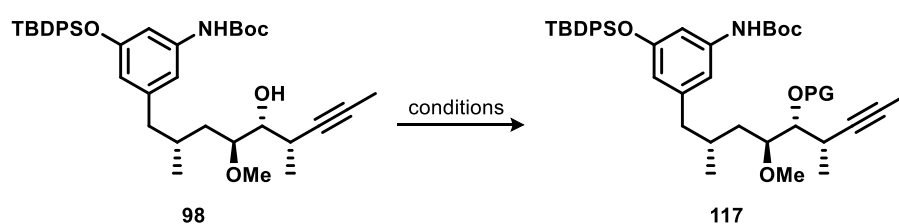

| entry | PG  | conditions   | result        |
|-------|-----|--|---------------|
| 1     | TBS | TBSCl, imidazole, CH <sub>2</sub> Cl <sub>2</sub> , rt, o/n                                | no conversion |
| 2     | TBS | TBSCl, imidazole, CH <sub>2</sub> Cl <sub>2</sub> , 40 °C, o/n                             | no conversion |
| 3     | TBS | TBSOTf, 2,6-lutidine, CH <sub>2</sub> Cl <sub>2</sub> , 40 °C, o/n                         | no conversion |
| 4     | TES | TESCl, <i>n</i> -BuLi, Et <sub>2</sub> O, rt, o/n  | no conversion |
| 5     | TMS | TMSCl, <i>n</i> -BuLi, Et <sub>2</sub> O, rt, o/n  | no conversion |
| 6     | TMS | TMSOTf, DIPA, CH <sub>2</sub> Cl <sub>2</sub> , 40 °C, o/n                                 | no conversion |
| 7     | TMS | bis(trimethylsilyl)acetamide, pyridine, 80 °C, o/n   | no conversion |
| 8     | PMB | 4-methoxybenzyl-2,2,2-trichloroacetimidate, CSA, CH <sub>2</sub> Cl <sub>2</sub> , rt, o/n | no conversion |
| 9     | MOM | MOMCl, NaH, DMF, rt, o/n   | no conversion |
| 10    | Ac  | Ac <sub>2</sub> O, imidazole, MeCN, rt, o/n  | no conversion |

**Scheme 26:** Unsuccessful protection of homopropargylic alcohol **98**.

### 3.3 Second Generation Synthesis

The second generation approach should feature a more convergent strategy, which could be achieved by introducing the arene moiety at a later stage in the synthesis. The retrosynthetic analysis is shown in Scheme 27. Fragment **119** displays a promising origin for introduction of the arene moiety, as well as the generation of the trisubstituted double bond. The aromatic moiety will be installed by a C(sp<sup>2</sup>)-(sp<sup>3</sup>) coupling of arene **120** with fragment **119**. The arene is readily available from 2-amino-5-nitrophenol (**121**). The trisubstituted double bond is again envisaged to be synthesized by transition metal-mediated coupling similar to the approach described above. The required central fragment **119** will be synthesized from alkyne **122** which can be obtained from commercially available (*R*)-Roche ester (**123**).

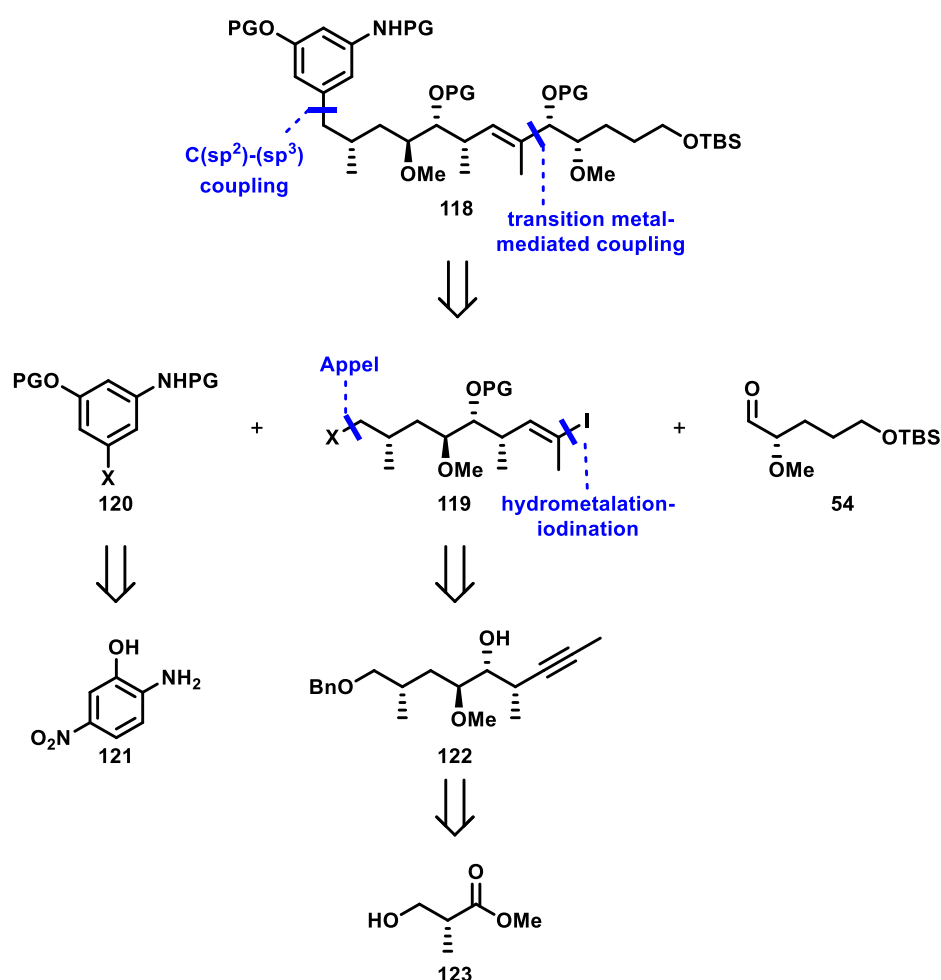

**Scheme 27:** Retrosynthetic analysis for the second generation synthesis. PG = undefined protection group

#### 3.3.1 Hydrozirconation-Iodination

The synthesis of alkyne **122** commenced with (*R*)-Roche ester (**123**) as published by Belardi and Micalizio.<sup>[101]</sup> Protection of the alcohol using benzyl 2,2,2-trichloroacetimidate and subsequent reduction of the ester with LiBH<sub>4</sub> furnished alcohol **125** in very good yields (Scheme 28). An alternative access to alcohol **125** circumventing the expensive Roche ester was also evaluated. For this, oxazolidinone **59** was prepared from Evans auxiliary **126**. Alkylation with benzyl chloromethyl ether (BOMCl) gave intermediate ether **127** and subsequent removal of the auxiliary by reduction with LiBH<sub>4</sub> did also provide alcohol **125**.

However, due to the acute toxicity of BOMCl and inferior yields, this alternative was not pursued further.

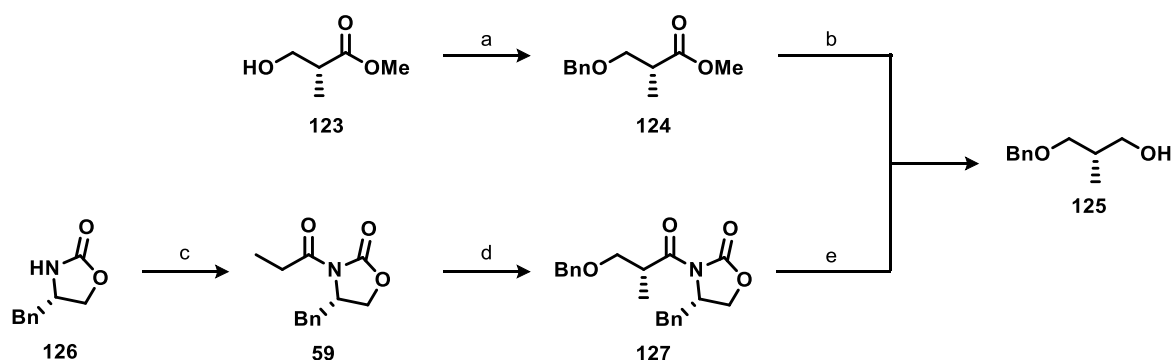

**Scheme 28:** Two possible syntheses of alcohol **125**. Conditions: a) Benzyl 2,2,2-trichloroacetimidate, TfOH, cyclohexane/CH<sub>2</sub>Cl<sub>2</sub> (2:1), 0 °C to rt, 36 h, 90%; b) LiBH<sub>4</sub>, MeOH, THF, 0 °C to rt, 1.5 h, 82%; c) *n*-BuLi, THF, -78 °C, 10 min, then propionyl chloride, -78 °C, 1 h, 91%; d) TiCl<sub>4</sub>, DIPEA, CH<sub>2</sub>Cl<sub>2</sub>, 0 °C, 1 h, then BOMCl, 0 °C, 6 h, 80%; e) LiBH<sub>4</sub>, MeOH/THF (3% MeOH), 0 °C to rt, 2 h, 65%.

The ensuing Appel reaction under standard conditions produced iodide **128**, which served as substrate for the subsequent Myers alkylation for stereoselective incorporation of the methoxy group at C-12 (Scheme 29). The aforementioned pseudoephedrine-derived amide **65** was employed as chiral auxiliary furnishing amide **129**. Removal of the auxiliary was extensively studied in the past and lithium amidotrihydroborate (LAB) was found to be the most effective reducing agent.<sup>[84,102]</sup> LAB was prepared by treatment of borane-ammonia complex with LDA. Reduction of the crude amide with LAB afforded desired alcohol **130** in 66% yield over two steps with an excellent diastereoselectivity (*d.r.* = 15:1). Column chromatographic purification of the amide intermediate prior to reduction did not prove necessary, as it did not improve either yield or diastereoselectivity.

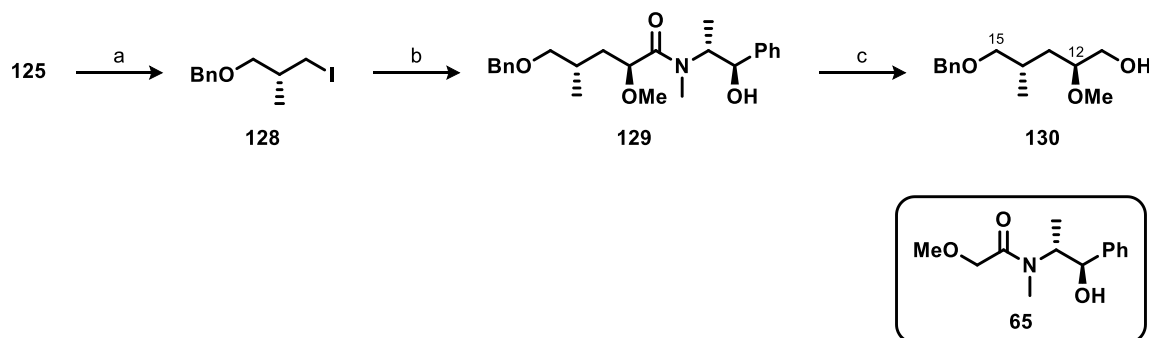

**Scheme 29:** Synthesis of alcohol **130**. Conditions: a) Imidazole, I<sub>2</sub>, PPh<sub>3</sub>, CH<sub>2</sub>Cl<sub>2</sub>, rt, 2 h, 95%; b) LiCl, DIPA, *n*-BuLi, THF, -78 °C, 15 min, then **65**, -78 °C, 1 h, 0 °C, 15 min, then **128**, 0 °C, 18 h; c) DIPA, *n*-BuLi, THF, -78 °C, 15 min, then borane-ammonia complex, 0 °C, 15 min, rt, 15 min, then **129**, 0 °C, 2 h, 66% o2s, *d.r.* = 15:1.

Alcohol **130** was then oxidized under Swern conditions which gave better yields compared to oxidation using DMP. Since the synthesis of aldehyde **131** was significantly quicker, easier and much more reproducible, than the synthesis of aldehyde **73**, the ensuing Marshall propargylation could be studied and optimized more comprehensively (Scheme 30). Under the conditions reported by Belardi and Micalizio homopropargylic alcohol **122** was obtained in 23% yield with a *d.r.* = 4:1 and partial debenzylation was observed (entry 1). Thus, the amount of Lewis acid was reduced to 1.5 eq. which proved beneficial, as the yield was increased to 34% and debenzylation was not observed anymore (entry 2). In addition, the amount of the allenylstannane could also be reduced to 1.5 eq. (entry 3) without affecting the



diastereoselectivity. Minimizing the amount of  $\text{BF}_3 \cdot \text{OEt}_2$  did not change this result, while using only 1.1 eq. of allenylstannane resulted in incomplete consumption of the aldehyde (entries 4 and 5). The above reactions were run at concentrations of 0.1 mol/L regarding the final concentration of the aldehyde in the reaction mixture. Increasing the concentration to 0.5 mol/L had a significant positive effect on the diastereoselectivity of the reaction, as it was increased to  $d.r. = 6:1$  (entry 6). The highest possible concentration for reactions on a 100 mg-scale was 0.7 mol/L as the reaction mixtures tended to freeze at higher concentrations. Interestingly, when the reaction was performed on larger scales than 100-120 mg, yield losses occurred. Therefore, the propargylation was carried out in parallel, running multiple reactions at this scale, which were then combined for purification. These optimized conditions furnished homopropargylic alcohol **122** in 47% and good diastereoselectivity ( $d.r. = 6:1$ , entry 7). The diastereoselectivity could not be further improved at lower temperatures (entry 8).

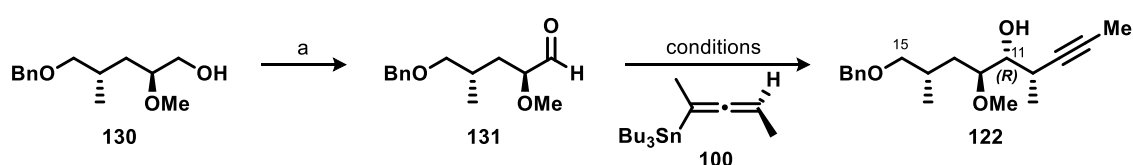

| entry          | conditions <sup>a, b</sup>                               | c [mol/L] <sup>c</sup> | result <sup>d</sup> |
|----------------|--|------------------------|---------------------|
| 1              | <b>100</b> (2.5), $\text{BF}_3 \cdot \text{OEt}_2$ (2.0) | 0.1                    | 23% $d.r. = 4:1$    |
| 2              | <b>100</b> (2.0), $\text{BF}_3 \cdot \text{OEt}_2$ (1.5) | 0.1                    | 34% $d.r. = 4:1$    |
| 3              | <b>100</b> (1.5), $\text{BF}_3 \cdot \text{OEt}_2$ (1.5) | 0.1                    | 35% $d.r. = 4:1$    |
| 4              | <b>100</b> (1.5), $\text{BF}_3 \cdot \text{OEt}_2$ (1.1) | 0.1                    | 36% $d.r. = 4:1$    |
| 5              | <b>100</b> (1.1), $\text{BF}_3 \cdot \text{OEt}_2$ (1.1) | 0.1                    | incomplete reaction |
| 6              | <b>100</b> (1.5), $\text{BF}_3 \cdot \text{OEt}_2$ (1.1) | 0.5                    | 42% $d.r. = 6:1$    |
| 7              | <b>100</b> (1.5), $\text{BF}_3 \cdot \text{OEt}_2$ (1.1) | 0.7                    | 47% $d.r. = 6:1$    |
| 8 <sup>e</sup> | <b>100</b> (1.5), $\text{BF}_3 \cdot \text{OEt}_2$ (1.1) | 0.6                    | 46% $d.r. = 6:1$    |
| 9              | <b>132</b> (1.5), $\text{BF}_3 \cdot \text{OEt}_2$ (1.1) | 0.7                    | 10% $d.r. = 3:1$    |
| 10             | <b>132</b> (1.5), $\text{TiCl}_4$ (1.1)                  | 0.7                    | 10% $d.r. = 3:1$    |

<sup>a</sup> typical reaction conditions:  $\text{CH}_2\text{Cl}_2$ ,  $-78^\circ\text{C}$ , 30 min

<sup>b</sup> equivalents used are indicated in parentheses

<sup>c</sup> final concentration of the aldehyde in the reaction mixture

<sup>d</sup> yield is given for the isolated 11-(*R*) diastereomer

<sup>e</sup> reaction was carried out at  $-100^\circ\text{C}$

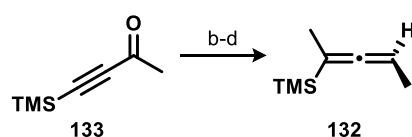

**Scheme 30:** Optimization for the Marshall propargylation towards alkyne **122** and preparation of allenylsilane **132**. Conditions: a)  $(\text{COCl})_2$ , DMSO,  $\text{CH}_2\text{Cl}_2$ ,  $-78^\circ\text{C}$ , 15 min, then **130**,  $-78^\circ\text{C}$ , 1.5 h, then  $\text{Et}_3\text{N}$ ,  $-78^\circ\text{C}$  to rt, 78%; b) (*S,S*)-Noyori catalyst, *i*-PrOH, rt, 18 h, 77%; c)  $\text{MsCl}$ ,  $\text{Et}_3\text{N}$ ,  $\text{CH}_2\text{Cl}_2$ ,  $-78^\circ\text{C}$ , 1 h; d)  $\text{CuBr} \cdot \text{SMe}_2$ , LiBr,  $\text{MeMgCl}$ , THF,  $-78^\circ\text{C}$ , 40 min, 43% o2s.

In contrast to the Marshall propargylations from the first generation synthesis, the separation of the diastereomers by chromatography was much easier here, and homopropargylic alcohol **122** was obtained as a single diastereomer in highest purity. Using allenylsilane **132** for the propargylation displays an alternative to access homopropargylic alcohol **122** avoiding the toxic stannane species. Commencing with asymmetric hydrogenation of commercially available 4-(trimethylsilyl)-3-butyn-2-one (**133**), followed by mesylation and subsequent treatment with methyl Grignard reagent and  $\text{CuBr}\cdot\text{SMe}_2$  provided the allenylsilane (43% o/s). Lithium dimethylcuprate could also be used for the final  $\text{S}_{\text{N}}2'$  displacement. However, this gave lower yields (21% o/s) and furthermore, this reagent is known to racemize allenes.<sup>[103]</sup> The yield of the propargylation with allenylsilane **132** under Lewis acid catalysis was lower than with the previous propargylations without improving the diastereoselectivity. Moreover, since purification and handling of the volatile silane required special care, propargylation with allenylstannane **100** remained the method of choice. Next, protection of the homopropargylic alcohol was considered. With the previous results in mind, the alcohol was regarded as relatively unreactive. Therefore, TBSOTf was chosen over TBSCl to examine silylation of said alcohol. Almost unexpectedly, protection of the alcohol proceeded in quantitative yield furnishing silyl ether **134** (Scheme 31). Due to this extraordinary result, no further protection groups were investigated at this stage. The hydrozirconation of the alkyne was again carried out using Schwartz reagent in THF at 50 °C. Iodination of the resulting organozirconium species was initially performed at room temperature. However, lower temperatures were advantageous and the reaction performed best at -78 °C providing vinyl iodide **135** in 85% yield as a single isomer. No formation of the regioisomer was observed.

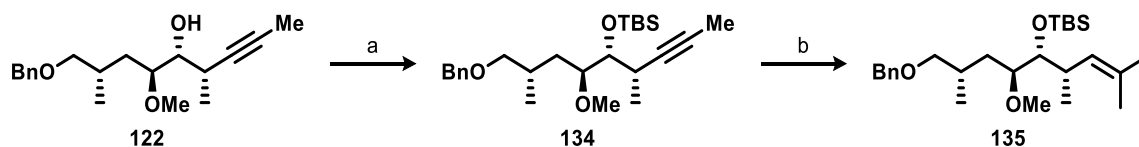

**Scheme 31:** Synthesis of vinyl iodide **135**. Conditions: a) TBSOTf, 2,6-lutidine,  $\text{CH}_2\text{Cl}_2$ , 0 °C to rt, 50 min, quant.; b)  $\text{Cp}_2\text{ZrHCl}$ , THF, 50 °C, 1 h, then  $\text{I}_2$ , -78 °C, 1 h, 82%.

The *in situ* synthesis of the Schwartz reagent from  $\text{Cp}_2\text{ZrCl}_2$  and DIBAL-H did not yield any significant benefit and was therefore not considered necessary.<sup>[104]</sup> Vinyl iodide **135** was thus prepared in 17% yield over 9 steps by a very reliable and efficient route. Furthermore, the vinyl iodide displayed very high stability upon storage at -25 °C. Studies towards the coupling with aldehyde **54** as well as studies towards the introduction of the arene were now envisaged.

### 3.3.2 Nozaki-Hiyama-Kishi Coupling

The Nozaki-Hiyama-Kishi (NHK) coupling is a method for the nucleophilic addition of alkenyl, alkynyl or aryl halides to aldehydes and ketones.<sup>[105–107]</sup> This powerful chromium-mediated reaction displays excellent chemoselectivities and a high functional group tolerance making it a versatile tool for C-C-bond formation in natural product synthesis.<sup>[108,109]</sup> Especially asymmetric variants of the NHK reaction are of great interest.<sup>[110]</sup> The general mechanism of the NHK reaction is depicted in Scheme 32. First, the  $\text{Ni}^{\text{II}}$  precatalyst is reduced by  $\text{Cr}^{\text{II}}$  to the catalytically active  $\text{Ni}^0$  species. This species inserts into the carbon-halogen bond of the vinyl halide (**A**) by an oxidative addition. The ensuing transmetalation

with  $\text{Cr}^{\text{III}}$  leads to a nucleophilic  $\text{Cr}^{\text{III}}$ -vinyl species (**B**) and the regeneration of the  $\text{Ni}^{\text{II}}$  precatalyst. Addition of the  $\text{Cr}^{\text{III}}$ -vinyl species to the aldehyde gives rise to a  $\text{Cr}^{\text{III}}$ -alkoxide (**C**). The resulting chromium-oxygen bond is the thermodynamic driving force of the reaction. Lastly, hydrolysis of the alkoxide gives the desired secondary alcohol (**D**).  $\text{Cr}^{\text{II}}$  is usually used in the reaction in the form of  $\text{CrCl}_2$  in high excess, since it is required for both alkoxide formation and regeneration of the catalytically active  $\text{Ni}^0$ . To suppress homocoupling of the  $\text{Ni}^{\text{II}}$ -vinyl species it is important to use as small amounts of the nickel catalyst as possible, typically  $<1 \text{ mol}\%$ .<sup>[111]</sup>

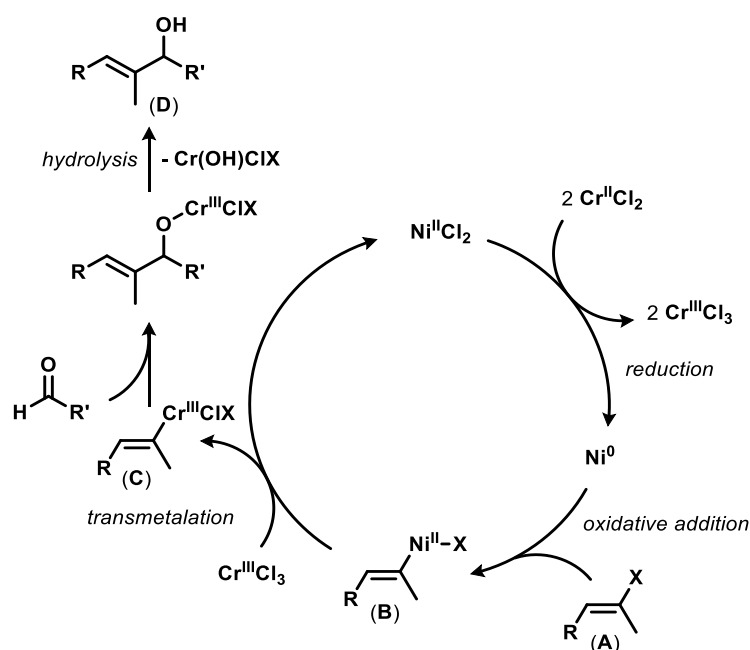

**Scheme 32:** General mechanism for the nickelcatalyzed chromium-mediated NHK reaction.

Kishi *et al.*<sup>[112]</sup> developed a protocol using chiral sulfonamide ligands for the enantioselective coupling. This method, which was already successfully applied in our group for the synthesis of carolacton<sup>[113–115]</sup>, should be implemented for coupling of vinyl iodide **135** and aldehyde **54** as well. The asymmetric induction occurs through the chiral sulfonamide ligand (*S*)-**136** which would give rise to the desired (*S*)-configured alcohol **137**. (*S*)-**136** was synthesized commencing with 3-methyl-2-nitrobenzoic acid (**138**) in 64% yield over 4 steps (Scheme 33).

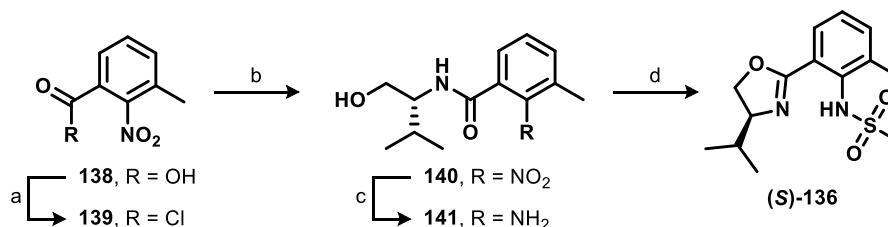

**Scheme 33:** Synthesis of the chiral sulfonamide ligand (*S*)-**136** according to Kishi *et al.*<sup>[112]</sup> Conditions: a) DMF,  $(\text{COCl})_2$ ,  $\text{CH}_2\text{Cl}_2$ ,  $0 \text{ }^\circ\text{C}$ , 4.5 h *then* rt, 18 h; b) (L)-valinol,  $\text{Et}_3\text{N}$ ,  $\text{CH}_2\text{Cl}_2$ ,  $0 \text{ }^\circ\text{C}$ , 30 min *then* rt, 6 h; c) 10% Pd/C,  $\text{H}_2$ , MeOH/THF (2.5:1), rt, 48 h; d) DMAP, MsCl, pyridine,  $0 \text{ }^\circ\text{C}$ , 1 h *then* rt, 8 h, 63% o4s.

Mechanistic details for the asymmetric induction are shown in Scheme 34. The exact transition state here is not known. However, studies by Kishi *et al.* based on X-ray structural analyses suggest the formation of the octahedral, tridentate  $\text{Cr}^{\text{II}}$ -complex **A** as the first step. Transmetalation with the  $\text{Ni}^{\text{II}}$ -vinyl species ( $\text{R}^1\text{-Ni}^{\text{II}}\text{-I}$ ) furnishes  $\text{Cr}^{\text{III}}$ -complex **B**.<sup>[111,112,116]</sup> In this complex, the *isopropyl* group is *cis* to the sulfonamide chain while the sulfonamide

nitrogen is *trans* to one of the chlorides. The oxygen atom of the sulfonamide is *trans* to the vinyl substituent ( $R^1$ ) and the aldehyde coordinates opposite to the sterically demanding methyl groups, so that the attack on the carbonyl function occurs from the *re*-face, which explains the diastereoselectivity.

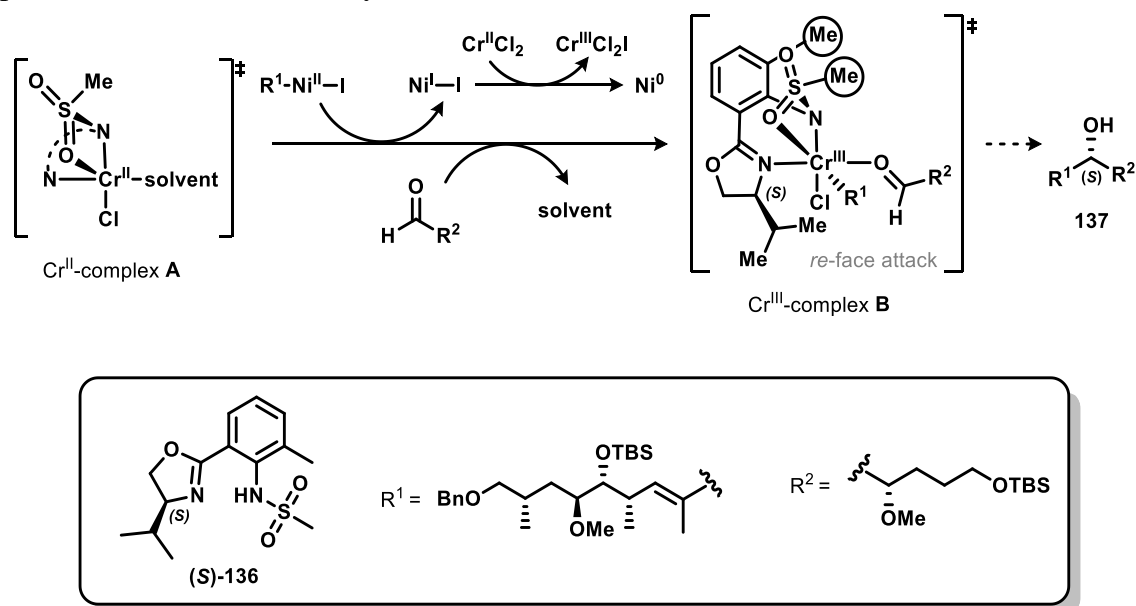

**Scheme 34:** Mechanistic details for the asymmetric NHK reaction using the chiral sulfonamide ligand (S)-136.

Under the conditions for the NHK established by Schmidt<sup>[114]</sup> and Ammermann<sup>[115]</sup>, formation of allylic alcohol **137** was not observed (Scheme 35). The reaction was repeated and as it was known from the studies in our group, that the NHK reaction is highly sensitive to moisture, great care was taken in terms of dryness. The vinyl iodide and the aldehyde were dried by azeotropic removal of water with benzene (3x) followed by stirring over molecular sieves (pellets, 4 Å). Vinyl iodide **135** was dried overnight in the absence of light and the  $\alpha$ -chiral aldehyde was dried for 5 h to avoid racemization. In addition, new batches of the chemicals used were bought of highest available purity and were stored in a glovebox. However, product formation was again not observed.

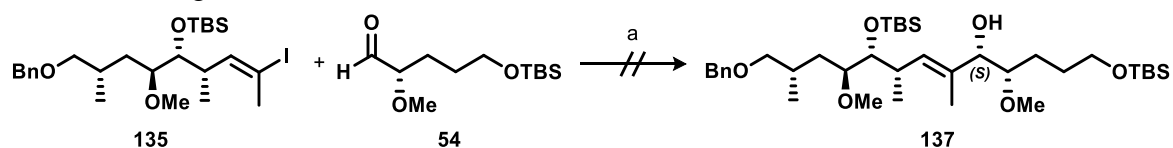

**Scheme 35:** Attempted enantioselective NHK coupling. Conditions: a) (S)-136, CrCl<sub>2</sub>, proton sponge, MeCN, rt, 2 h, then **135**, **54**, NiCl<sub>2</sub>(dppp), MeCN, rt, 20 h.

Since the asymmetric NHK did not provide any product an achiral NHK, followed by separation of the diastereomers, oxidation of the undesired alcohol and stereoselective reduction seemed worthwhile. In initial trials with the achiral NHK, product **142** was only produced in minimal amounts (Scheme 36, entry 1). Besides some recovered starting material, the main product was (*Z*)-alkene **143**. Increasing the amount of CrCl<sub>2</sub> and changing the solvent from MeCN to DMSO proved beneficial (entries 2 and 3). Also, a higher nickel catalyst loading of 3 w% (with respect to the amount of CrCl<sub>2</sub>) improved the yield slightly (entry 4). In addition to the above drying procedure of the substrates, CrCl<sub>2</sub> was then also dried prior to use at 230 °C for 2.5 h under vacuum. Increasing the excess of CrCl<sub>2</sub> in the

reaction to 8.7 equivalents did result in an increased product formation of 26% yield, which could not be improved further (entry 5). Different catalysts such as NiCl<sub>2</sub>(dppp) or NiCl<sub>2</sub>·glyme were less effective than NiCl<sub>2</sub> (entries 6 and 7). Unfortunately, despite these adjustments, under all conditions a non-negligible amount of alkene was formed and the isolated allylic alcohol **142** was obtained as a diastereomeric mixture (*d.r.* = 1:1) and separation of the diastereomers was not possible.

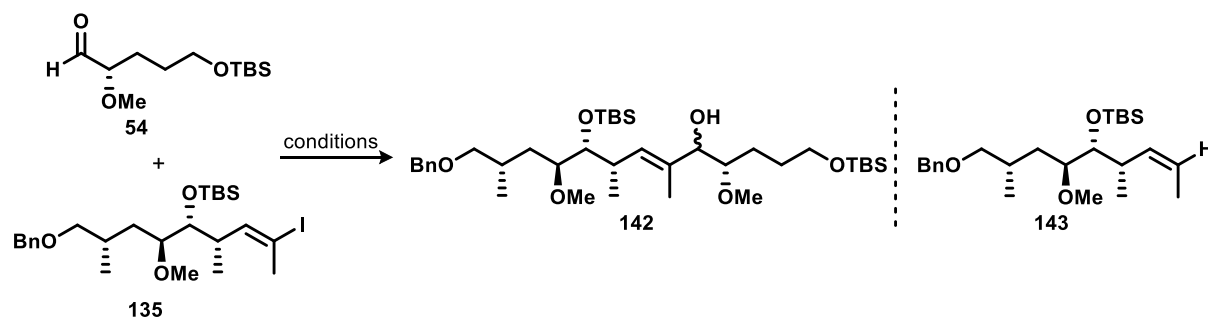

| entry          | conditions <sup>a, b</sup>   | result <sup>d</sup> |
|----------------|--|---------------------|
| 1              | CrCl <sub>2</sub> (5.0 eq.), NiCl <sub>2</sub> (1 w%), MeCN, 24 h        | 3%                  |
| 2              | CrCl <sub>2</sub> (7.0 eq.), NiCl <sub>2</sub> (1 w%), MeCN, 24 h        | 8%                  |
| 3              | CrCl <sub>2</sub> (7.0 eq.), NiCl <sub>2</sub> (1 w%), DMSO, 24 h        | 10%                 |
| 4              | CrCl <sub>2</sub> (7.0 eq.), NiCl <sub>2</sub> (3 w%), DMSO, 42 h        | 12%                 |
| 5 <sup>c</sup> | CrCl <sub>2</sub> (8.7 eq.), NiCl <sub>2</sub> (3 w%), DMSO, 42 h        | 26%                 |
| 6 <sup>c</sup> | CrCl <sub>2</sub> (8.7 eq.), NiCl <sub>2</sub> (dppp) (3 w%), DMSO, 42 h | 19%                 |
| 7 <sup>c</sup> | CrCl <sub>2</sub> (8.7 eq.), NiCl <sub>2</sub> ·glyme (3 w%), DMSO, 42 h | 20%                 |

<sup>a</sup> the amount of nickel catalyst is given in w% with respect to the amount of CrCl<sub>2</sub>

<sup>b</sup> all reaction were carried out at rt

<sup>c</sup> CrCl<sub>2</sub> was dried at 230 °C for 2.5 h in vacuum

<sup>d</sup> in each reaction *d.r.* = 1:1

**Scheme 36:** Non-asymmetric NHK reaction of aldehyde **54** and vinyl iodide **135**.

The assignment of the absolute configuration at C-7 and distinction between the two diastereomers was based on a comparison of the crude NMR data with experimental data of the SNAC ester of 8-desmethyl-*seco*-progeldanamycin and intermediate structures of this synthesis from the studies of Hermans.<sup>[75]</sup> Therefore, the mixture of the two allylic alcohols was oxidized in the next step with DMP furnishing  $\alpha,\beta$ -enone **144** in good yield (Scheme 37, B). A very well suited method for the stereoselective reduction of such  $\alpha,\beta$ -enones is the CBS-reduction (Corey-Bakshi-Shibata), that employs oxazaborolidines as chiral catalysts for the borane-mediated enantioselective reduction of ketones.<sup>[117]</sup> Here, (*S*)-2-methyl-CBS-oxazaborolidine (**145**) should be used for the reduction. Coordination of the electrophilic BH<sub>3</sub> to the nitrogen atom of **145** activates BH<sub>3</sub> as hydride donor. The resulting strongly Lewis acidic complex binds to the ketone at the more sterically accessible electron lone pair. This minimizes the steric interactions between the ketone and the oxazaborolidine. In the case of acyclic enones the olefinic part generally behaves as the large group R<sub>L</sub> (Scheme 37, A).<sup>[118]</sup> Thus, it was expected that the reduction of enone **144** with (*S*)-2-methyl-CBS-oxazaborolidine

(**145**) would proceed with high diastereoselectivity. Against the expectations, an inseparable diastereomeric mixture (*d.r.* = 1:1) of allylic alcohol **142** was obtained in 50% yield (Scheme 37, B).

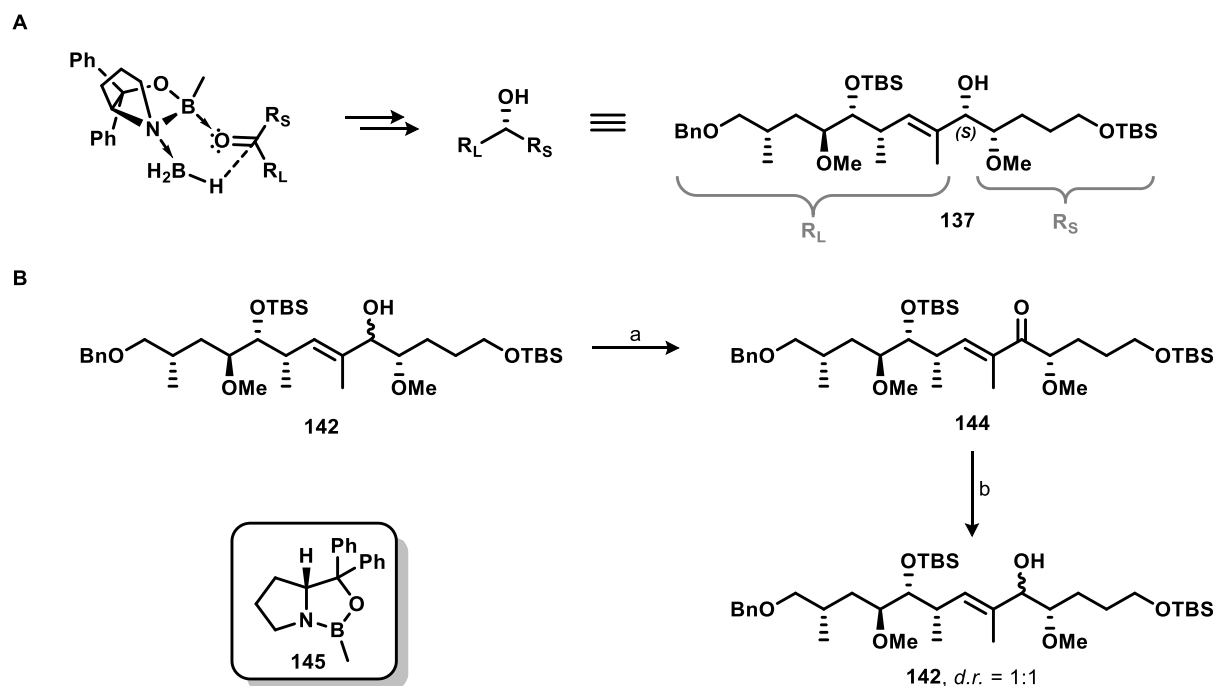

**Scheme 37:** **A**) Coordination of the ketone and the oxazaborolidine-borane complex in the CBS-reduction.  $R_S$  = small residue,  $R_L$  = large residue. **B**) Oxidation of **142** followed by attempted stereoselective reduction of enone **144**. Conditions: a) DMP,  $\text{NaHCO}_3$ ,  $\text{CH}_2\text{Cl}_2$ ,  $0^\circ\text{C}$  to rt, 2 h, 60%; b) (*S*)-2-Methyl-CBS-oxazaborolidine (**145**),  $\text{BH}_3\text{:SMe}_2$ , THF,  $-10^\circ\text{C}$ , 6 h, 50%, *d.r.* = 1:1.

It appears that the reagent-controlled stereoselectivity is significantly mismatched<sup>[119]</sup> with the substrate-induced diastereoselectivity. The amount of material recovered was not sufficient to oxidize the alcohol again and investigate further stereoselective reductions. In view of this poor result and the aforementioned challenges associated with the NHK reaction, different conditions for the introduction of the pent-2-ene-1,5-diol motif were sought.

### 3.3.3 Halogen-Metal Exchange

Next, a halogen-metal exchange with vinyl iodide **135** followed by 1,2-addition to aldehyde **54** was planned to install the trisubstituted double bond. Simple lithium halogen exchange was not suitable as the stereochemical considerations revealed that the desired product is the anti-Felkin-Anh product. Therefore, chelating conditions are required to furnish (*S*)-configured allylic alcohol **137** which would be favored according to the Cram chelate model (Scheme 38).

In fact, as it was shown above by the synthesis of eastern fragment **38** for the RCM approach (see page 19), Grignard reaction under chelating conditions gave rise to the (*S*),(*S*)-configured alcohol. Although this reaction proceeded with rather mediocre selectivity (*d.r.* = 4:1), this method seemed worth trying. Unfortunately, preparation of the required vinyl Grignard reagent *in situ*<sup>[120]</sup> and subsequent addition to the aldehyde was not successful (Scheme 39).

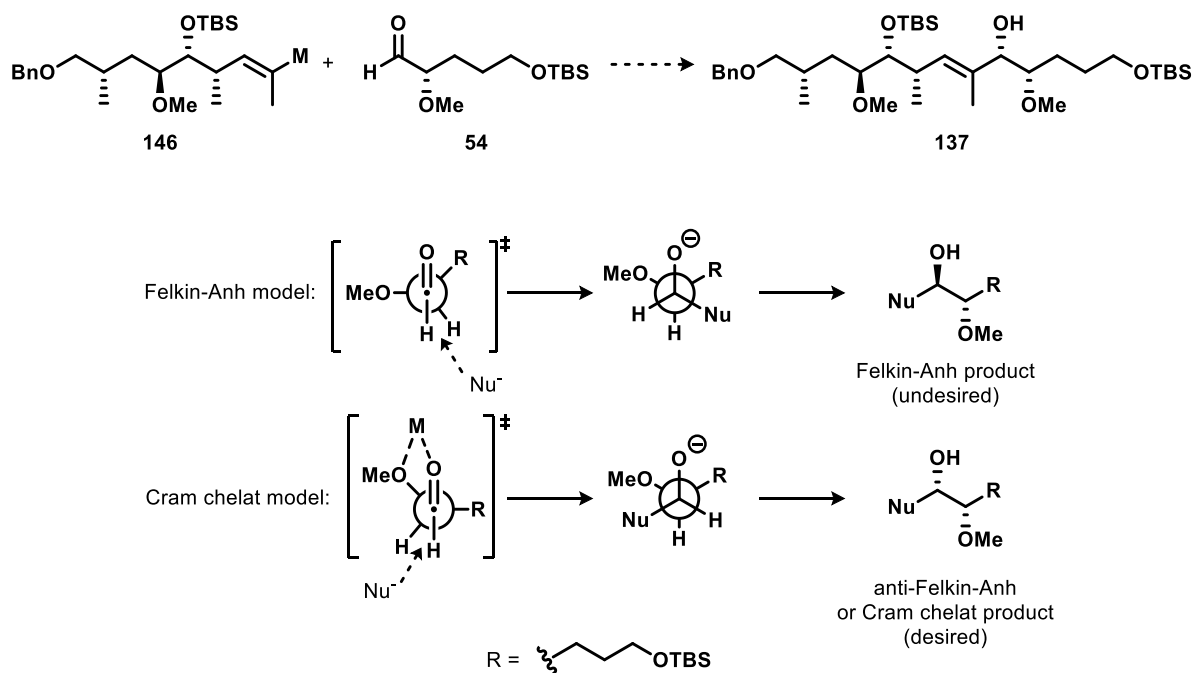

**Scheme 38:** Stereochemical analysis for the 1,2-addition towards allylic alcohol **137**.

In general, there is a rather limited choice of methods available for the synthesis of Grignard reagents from vinyl iodides. Furthermore, due to the higher reactivity of the iodide, compared to other halogenides, as a possible side reaction the Wurtz reaction (homocoupling of the vinyl iodide) could occur. As an alternative approach the generation of an organozinc species was envisaged. Divinylzinc additions to  $\alpha$ -alkoxyaldehydes were reported with high diastereomeric ratios and good yields.<sup>[121–123]</sup> For example, in their studies towards the C1-C8 fragment of autolytimycin in 2013, Shen *et al.* faced similar difficulties in terms of diastereoselectivity and yield for the addition of *isopropenylmagnesium bromide* to an  $\alpha$ -oxygenated aldehyde (**147**). Therefore, they developed a chelate-controlled *isopropenylation* method (Scheme 40) for the preparation of **148**.<sup>[123]</sup> In their synthesis, the addition of *diisopropenylzinc* to an aldehyde under magnesium halide chelation in a dichloromethane/toluene mixed solvent proceeded in high yields and diastereoselectivities. It is noteworthy, that *diisopropenylzinc* did not perform well on its own. Addition of the magnesium halide to the reaction, however, increased the yield and stereoselectivity dramatically. It was postulated that the magnesium ion activates the carbonyl group by complexation and additionally provides stereocontrol as shown by the transition state in Scheme 40.

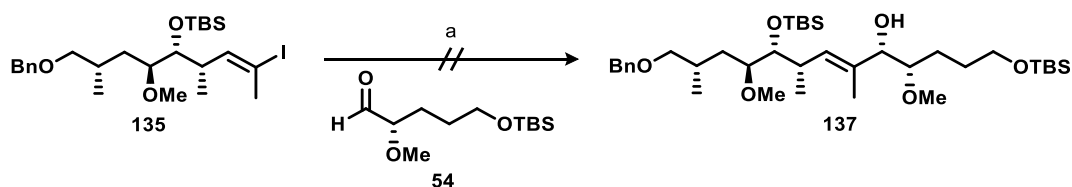

**Scheme 39:** Attempted Grignard reaction of vinyl iodide **135** with aldehyde **54**. Conditions: a) *i*-PrMgBr, THF,  $-25\text{ }^\circ\text{C}$ , 5 h.

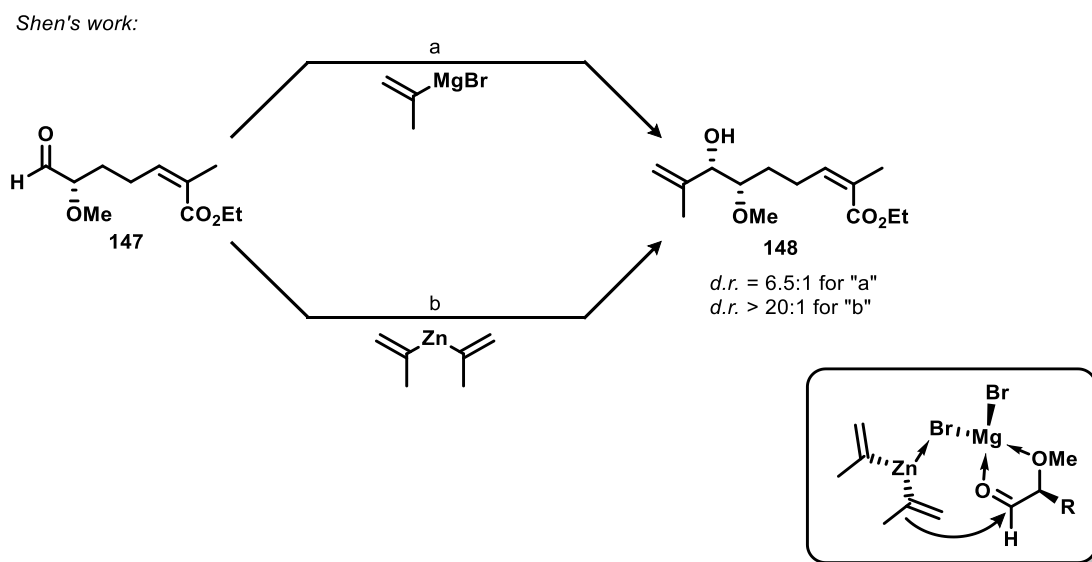

**Scheme 40:** Chelate-controlled isoprenylation method developed by Shen *et al.* and the proposed transition state (box).<sup>[123]</sup> Conditions: a) isopropenylmagnesium bromide,  $\text{MgBr}_2 \cdot \text{OEt}_2$ ,  $\text{CH}_2\text{Cl}_2$ ,  $-78^\circ\text{C}$ , 1 h, 54%,  $d.r. = 6.5:1$ ; b) isopropenylmagnesium bromide,  $\text{ZnCl}_2$ ,  $\text{CH}_2\text{Cl}_2$ ,  $0^\circ\text{C}$ , 5 h, then **147**, PhMe,  $-78^\circ\text{C}$ , 30 min, then  $0^\circ\text{C}$ , 30 min, 85%,  $d.r. > 20:1$ .

To evaluate this method, the synthesis of eastern fragment **38** should be repeated using Shen's method. Accordingly, isopropenylmagnesium bromide which is commercially available as a solution in THF was carefully evaporated to dryness on a rotovap under inert gas atmosphere. Then, the solvent was changed to  $\text{CH}_2\text{Cl}_2$  and treatment with  $\text{ZnCl}_2$  furnished the reactive organozinc species. The supplemental addition of  $\text{MgBr}_2$  was not necessary as it was formed *in situ*. Gratifyingly, subsequent addition of aldehyde **54** gave rise to allylic alcohol **38** in good yield and an exceptional diastereoselectivity ( $d.r. = 19:1$ ) (Scheme 41).

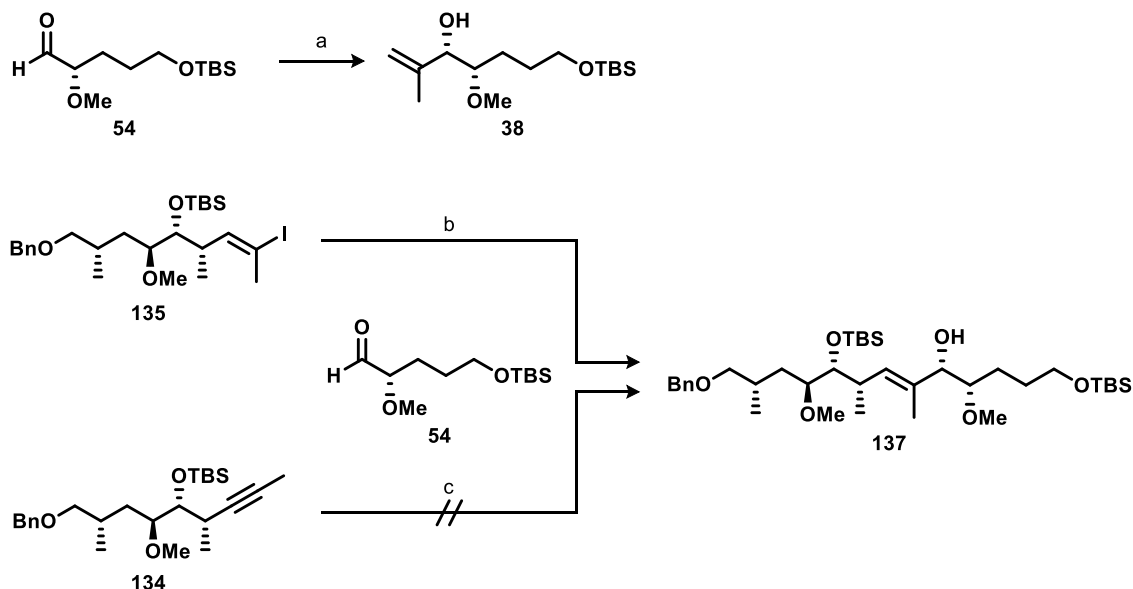

**Scheme 41:** Successful implementation of Shen's chelate-controlled isoprenylation method for the synthesis of eastern fragment **38** and attempted 1,2-addition of a vinyl zincate, derived from vinyl iodide **135** or alkyne **134**, with aldehyde **54**. Conditions: a) isopropenylmagnesium bromide,  $\text{ZnCl}_2$ ,  $\text{CH}_2\text{Cl}_2$ ,  $0^\circ\text{C}$  to rt, 5 h, then **54**, PhMe,  $-78^\circ\text{C}$ , 30 min, then  $0^\circ\text{C}$ , 30 min, 67%,  $d.r. = 19:1$ ; b)  $n\text{-BuLi}$ ,  $-78^\circ\text{C}$ , THF, then  $\text{Me}_2\text{Zn}$ , 10 min, then **54**,  $-78^\circ\text{C}$ , 30 min, then  $0^\circ\text{C}$ , 30 min, 3%,  $d.r. = 1.2:1$ ; c)  $\text{Cp}_2\text{ZrHCl}$ ,  $50^\circ\text{C}$ , 1 h, PhMe, then  $\text{Me}_2\text{Zn}$ ,  $-78^\circ\text{C}$  20 min,  $0^\circ\text{C}$ , 20 min, then **54**,  $0^\circ\text{C}$ , 1.5 h.



Thus, this method proved to be far superior to the synthesis of **38** mentioned above. Inspired by these results, this approach appeared very promising for the envisaged fragment coupling. Formation of the vinyl organozinc species was envisaged by lithiation of the vinyl iodide followed by transmetalation. The addition of magnesium-based Lewis acids could then provide the magnesium ion needed to promote aforementioned complex formation. Lithiation was carried out with *n*-BuLi and transmetalation with Me<sub>2</sub>Zn at -78 °C in THF. For complexation MgBr<sub>2</sub>·OEt<sub>2</sub> was added, but unfortunately after the addition of the aldehyde, the (*Z*)-alkene was the major product and the desired allylic alcohol was obtained only in 3% yield and a *d.r.* = 1.2:1. To see whether MgBr<sub>2</sub>·OEt<sub>2</sub> could have hampered the reaction, it was repeated without the Lewis acid, but the result was identical. Using *t*-BuLi or Et<sub>2</sub>Zn did not change the result, nor did decreasing the temperature for lithiation to -105 °C. *In situ* zincation of the intermediate zirconium species after hydrozirconation of alkyne **134** was also tried but did not work out as planned and no product formation was observed.

### 3.3.4 Titanium Alkoxide-Mediated Reductive Coupling

Next, a titanium alkoxide-mediated reductive coupling was envisaged, which would enable the direct coupling of alkyne **134** with aldehyde **54**. This methodology has been extensively studied by Micalizio *et al.* (Scheme 42). In their studies towards the synthesis of macrolide antibiotics the authors developed a pentenyl dianion-based strategy for the synthesis of ene-1,5-diols.<sup>[124,125]</sup> They envisioned a two-step process in which a synthetic equivalent of pentenyl dianion **149** could serve to combine two differently functionalized aldehydes (**150** and **151**) and provide direct access to a functionalized polypropionate.

Micalizio's idea:

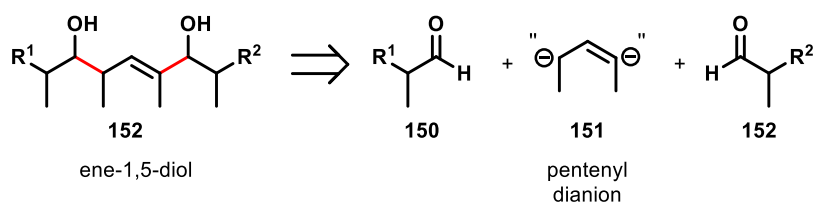

Synthetic implementation:

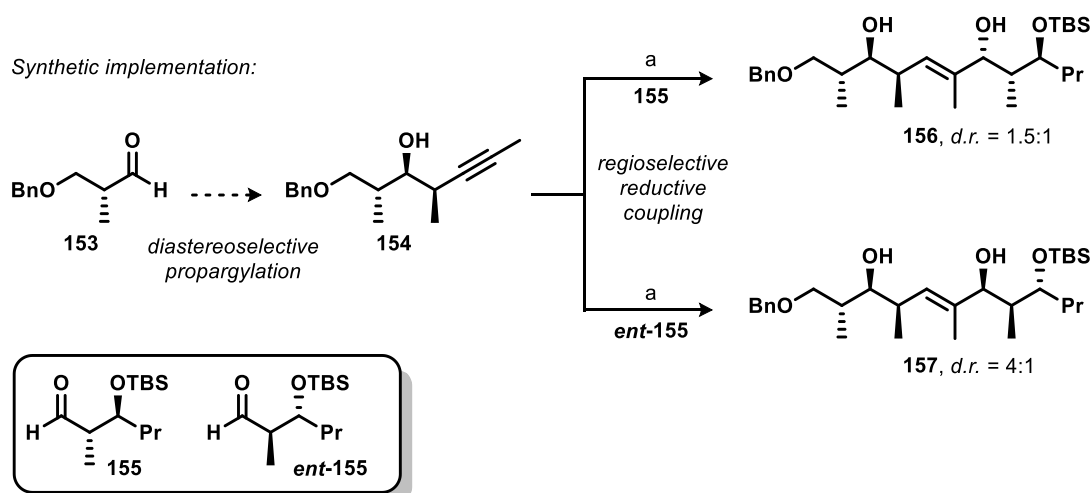

**Scheme 42:** Micalizio's idea for a pentenyl dianion-based two-step strategy for the synthesis of ene-1,5-diols.<sup>[124]</sup> Conditions: a) *n*-BuLi, PhMe, -78 °C, then ClTi(O*i*-Pr)<sub>3</sub>, *c*-C<sub>3</sub>H<sub>9</sub>MgCl, -78 °C to -40 °C, 1 h, then BF<sub>3</sub>·OEt<sub>2</sub>, then **155/ent-155**, -78 °C, 1 h, 66% for **156**, 65% for **157**.

The first step was the stereoselective propargylation furnishing internal alkyne **154**. The second step was the reductive coupling in presence of the free homopropargylic alcohol that would generate the trisubstituted olefin. For this purpose, a process based on low-valent titanium alkoxide was developed, which enables alkyne-aldehyde coupling. Deprotonation of the homopropargylic alcohol with *n*-BuLi and ensuing treatment with chlorotitanium triisopropoxide and cyclopentylmagnesium chloride, followed by addition of  $\text{BF}_3 \cdot \text{OEt}_2$  and aldehyde **155** and *ent*-**155** gave rise to ene-1,5-diols **156** and **157**.

Mechanistically, the generated alkoxide forms a bicyclic metallacyclopropene (**158**) whose structure is retained in the transition state for reductive coupling, thus favoring metallacycle **159** over the bridged bicyclic isomer **160**, directing the regioselectivity towards the observed product **161** (Scheme 43).

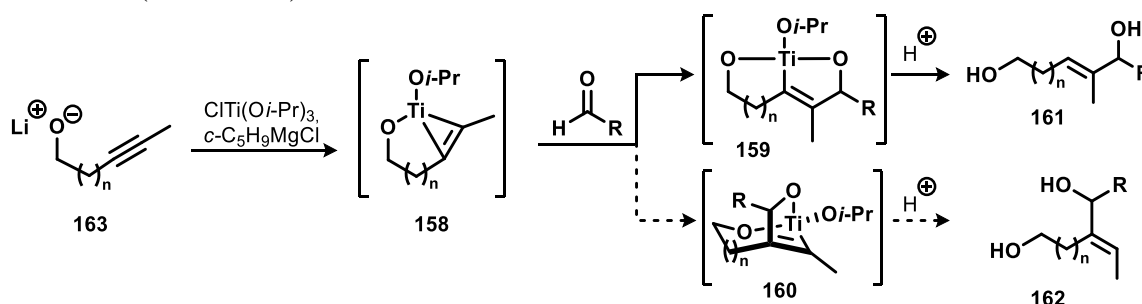

**Scheme 43:** Postulated mechanism explaining the regioselectivity in the titaniumalkoxide-mediated reductive coupling of alkynes and aldehydes.<sup>[125]</sup>

Under the conditions established by Micalizio *et al.*, reductive coupling with the  $\alpha$ -methyl branched aldehydes **155** and *ent*-**155** gave the Felkin-Anh products. As it was shown above, addition to  $\alpha$ -methoxy branched aldehyde **54** requires chelation control to obtain the desired anti-Felkin-Anh product. Thus, the conditions were modified accordingly and  $\text{BF}_3 \cdot \text{OEt}_2$  was substituted by  $\text{MgBr}_2 \cdot \text{OEt}_2$  as a chelating Lewis acid.

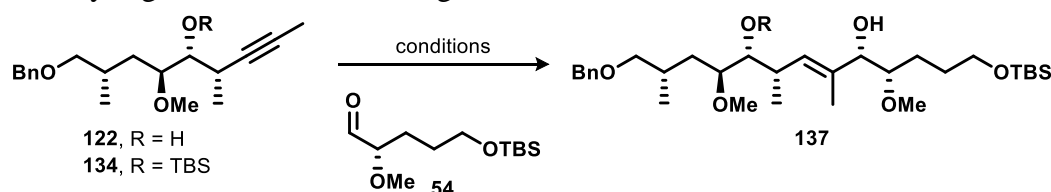

| entry | alkyne     | conditions   | result <sup>a</sup>                          |
|-------|------------|--|--|
| 1     | <b>122</b> | 1) <i>n</i> -BuLi, PhMe, -78 °C, 5 min<br>2) ClTi(O <i>i</i> -Pr) <sub>3</sub> (2.0 eq.), <i>c</i> -C <sub>5</sub> H <sub>9</sub> MgCl (4.0 eq.), -78 to -30 °C, 1 h<br>3) MgBr <sub>2</sub> ·OEt <sub>2</sub> (2.0 eq.), -78 °C then <b>54</b> (1.5 eq.), 30 min  | complex mixture,<br>trace amounts of product |
| 2     | <b>122</b> | 1) <i>n</i> -BuLi, PhMe, -78 °C, 30 min<br>2) ClTi(O <i>i</i> -Pr) <sub>3</sub> (2.0 eq.), <i>c</i> -C <sub>5</sub> H <sub>9</sub> MgCl (4.0 eq.), -78 to -30 °C, 2 h<br>3) MgBr <sub>2</sub> ·OEt <sub>2</sub> (2.0 eq.), -78 °C then <b>54</b> (1.5 eq.), 30 min | complex mixture,<br>trace amounts of product |
| 3     | <b>134</b> | 1) ClTi(O <i>i</i> -Pr) <sub>3</sub> (2.0 eq.), <i>c</i> -C <sub>5</sub> H <sub>9</sub> MgCl (4.0 eq.), -78 to -30 °C, 1 h<br>2) MgBr <sub>2</sub> ·OEt <sub>2</sub> (2.0 eq.), -78 °C then <b>54</b> (1.5 eq.), 30 min  | 11%, d.r. = 1.2:1                            |
| 4     | <b>134</b> | 1) ClTi(O <i>i</i> -Pr) <sub>3</sub> (2.0 eq.), <i>c</i> -C <sub>5</sub> H <sub>9</sub> MgCl (4.0 eq.), -78 to -10 °C, 2 h<br>2) MgBr <sub>2</sub> ·OEt <sub>2</sub> (2.0 eq.), -78 °C then <b>54</b> (1.5 eq.), 30 min  | 10%, d.r. = 1.2:1                            |

<sup>a</sup> in all reactions the main product was the (Z)-alkene **143**

**Scheme 44:** Titanium alkoxide-mediated reductive coupling of alkynes **122** and **134** with aldehyde **54**.

Homopropargylic alcohol **122** was then subjected to the reductive coupling, which resulted in a complex mixture and the desired product could only be obtained in trace amounts (Scheme 44, entry 1). Extending the reaction time for alkoxide formation and subsequent complexation did not improve this result (entry 2). When the protected homopropargylic alcohol (**134**) was used, the reaction was much cleaner, and product **137** could be isolated in 11% yield (entry 3). However, an inseparable mixture of diastereomers with an unsatisfactory diastereoselectivity of 1.2:1 was obtained. Raising the temperature for titanium complex formation to  $-10\text{ }^{\circ}\text{C}$  and extending the reaction time did not improve the yield or the *d.r.* (entry 4). Under all conditions (*Z*)-alkene **143** was the major product.

Since the introduction of the ene-1,5-diol motif proved to be a significant challenge in the synthesis and the substantial formation of (*Z*)-alkene **143** in all approaches reduced the amount of material available for further transformations immensely, emphasis was placed on the introduction of the aromatic moiety. It was assumed that after the successful installation of the arene, sufficient material could be provided to proceed with the achiral NHK followed by oxidation, which was the most successful method at this point, and then find suitable conditions for stereoselective reduction.

### 3.3.5 Introduction of the Aromatic Moiety

#### 3.3.5.1 C(sp<sup>2</sup>)-(sp<sup>3</sup>) Cross-Coupling

For the introduction of the arene, a C(sp<sup>2</sup>)-(sp<sup>3</sup>) Suzuki-Miyaura coupling of an arylboronic ester and an alkyl halide was envisaged. This transition metal-catalyzed cross-coupling is one of the most used transformations in synthetic chemistry.<sup>[126,127]</sup> Since its discovery in 1979, great progress has been made, mainly in the field of ligand design. Mild reaction conditions, short reaction times, and broad functional group tolerance have led to this reaction becoming arguably the most attractive cross-coupling approach. Phosphine complexes of palladium are the predominant catalysts used for C(sp<sup>2</sup>)-(sp<sup>2</sup>) Suzuki-couplings. However, C(sp<sup>2</sup>)-(sp<sup>3</sup>) couplings are more problematic especially when alkyl halides are used as coupling partners. There are different reasons why alkyl halides are thought to be challenging substrates. The oxidative addition of transition metals toward alkyl halides is relatively slow compared to aryl and vinyl halides, because C(sp<sup>3</sup>)-X bonds are more electron-rich than their C(sp<sup>2</sup>)-X counterpart.<sup>[128,129]</sup> The resulting alkyl metal intermediates are less stable than aryl or alkenyl metal species, because they lack the  $\pi$  electrons that interact with the empty d orbitals of the metal center. Due to this instability, side reactions such as  $\beta$ -hydride or heteroatom elimination might occur, which can outcompete intermolecular transmetalation and reductive elimination (Scheme 45).<sup>[130,131]</sup> Nevertheless, substantial progress has been made over the last decades to overcome these issues. The design of new catalyst systems enabled the use of alkyl halides in cross-coupling reactions. In addition to palladium and copper, especially nickel proved to be very powerful for the coupling of primary alkyl halides with organoboron reagents.<sup>[131,133–137]</sup> Therefore, in the search for a suitable catalyst system for the present work, the focus was mainly put on these three transition metals. As a model substrate to screen different catalyst systems, intermediate iodide **128** was chosen.

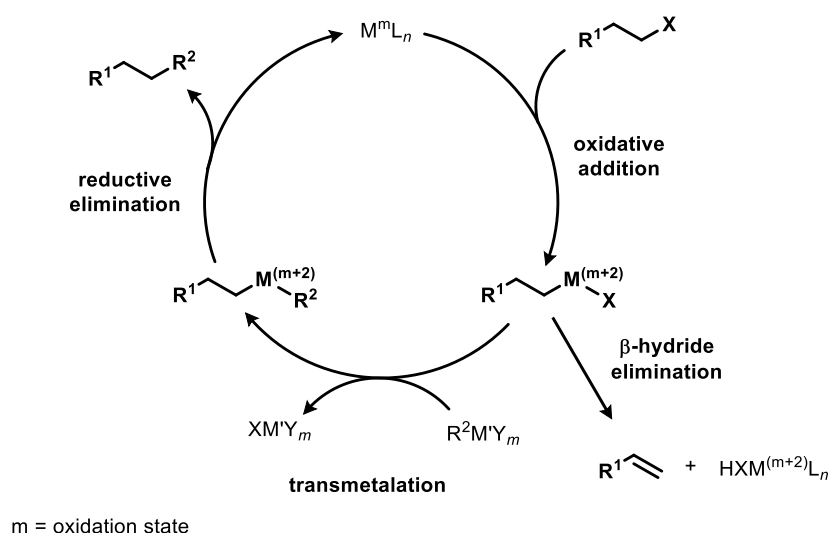

**Scheme 45:** Generalized catalytic cycle of the cross-coupling of alkyl electrophiles.<sup>[132]</sup>

As for the arene, pinacol boronic ester **164**, which was readily accessible from 3-bromophenol (**165**) in two steps, was chosen as a model substrate (Scheme 46). A substrate already bearing the aniline was deliberately not chosen, due to the fact, that the bis-protected aniline was not available at this time, since the protection turned out to be rather challenging (*vide infra*). Once suitable coupling conditions would be found, the protecting group strategy for the aniline would be chosen accordingly.

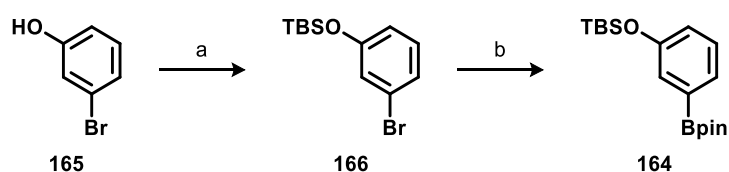

**Scheme 46:** Synthesis of pinacol boronic ester **164**. Conditions: a) TBSCl, imidazole, CH<sub>2</sub>Cl<sub>2</sub>, rt, 2 h, 77%; b) B<sub>2</sub>pin<sub>2</sub>, KOAc, Pd(dppf)Cl<sub>2</sub>·CH<sub>2</sub>Cl<sub>2</sub>, 1,4-dioxane, microwave-irradiation, 120 °C, 20 min, 81%.

The results of the coupling of **128** and **164** under different conditions as shown in Scheme 47 were very sobering. Couplings using various stable Ni(II) precatalysts with KO*t*-Bu or *t*-BuONa as base and in combination with different ligands were evaluated at 40 °C or 60 °C and at 120 °C under microwave irradiation (entries 1 to 7). Although conditions were chosen, that were highly promising according to the published results<sup>[138–141]</sup>, in no case was product formation observed. Using Ni(cod)<sub>2</sub> as Ni(0) source with KO*t*-Bu in 2-butanol at 60 °C<sup>[142,143]</sup> provided trace amounts of desired product **167** after 24 h (entry 8). Performing the reaction at 120 °C under microwave irradiation gave the product in a maximum yield of 8% (entry 9). Employing Pd(OAc)<sub>2</sub> as precatalyst with *Pt*-Bu<sub>2</sub>Me as ligand and KO*t*-Bu as base at room temperature was reported for the successful coupling of alkyl bromides, but no conversion was encountered (entries 10 and 11).<sup>[144]</sup> No product formation was observed for the copper-catalyzed cross-coupling<sup>[145]</sup> using CuI and LiO*t*-Bu at room temperature in THF either (entry 12). Changing the solvent to DMF and performing the reaction at 60 °C led to product formation, but only in trace amounts (entry 13). In all promising reactions, alkene **168** was the main product due to  $\beta$ -hydride elimination.

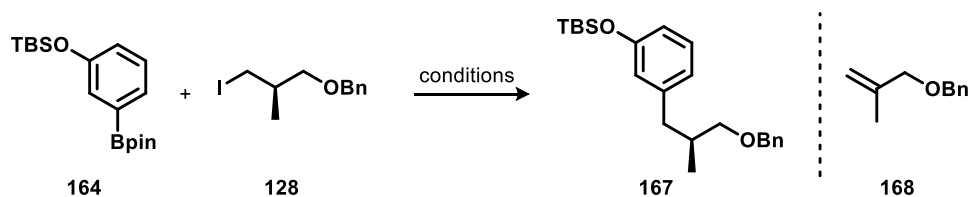

| entry | conditions <sup>a</sup>  | ligand | result <sup>b</sup> |
|-------|--|--------|---------------------|
| 1     | NiBr <sub>2</sub> (dme), KO <sup>t</sup> -Bu, 2-butanol, dioxane, 60 °C, 18 h                    | L1     | no conversion       |
| 2     | NiBr <sub>2</sub> •diglyme, KO <sup>t</sup> -Bu, dioxane, 60 °C, 18 h                            | L2     | no conversion       |
| 3     | NiBr <sub>2</sub> •diglyme, KO <sup>t</sup> -Bu, dioxane, 120 °C, MW-irrad., 20 min              | L2     | no conversion       |
| 4     | NiBr <sub>2</sub> •diglyme, KO <sup>t</sup> -Bu, benzene, 60 °C, 18 h                            | L2     | no conversion       |
| 5     | NiCl <sub>2</sub> (dme), <i>t</i> -BuONa, benzene, 40 °C, 18 h                                   | L3     | no conversion       |
| 6     | NiCl <sub>2</sub> (dme), <i>t</i> -BuONa, benzene, 40 °C, 18 h                                   | L4     | no conversion       |
| 7     | NiCl <sub>2</sub> (dme), <i>t</i> -BuONa, benzene, 120 °C, MW-irrad. 20 min                      | L4     | no conversion       |
| 8     | Ni(cod) <sub>2</sub> , KO <sup>t</sup> -Bu, 2-butanol, 60 °C, 24 h                               | L4     | traces              |
| 9     | Ni(cod) <sub>2</sub> , KO <sup>t</sup> -Bu, 2-butanol, 120 °C, MW-irrad., 20 min                 | L4     | 8%                  |
| 10    | Pd(OAc) <sub>2</sub> , P <sup>t</sup> -Bu <sub>2</sub> Me, KO <sup>t</sup> -Bu, TAA, rt, 18 h    |        | no conversion       |
| 11    | Pd(OAc) <sub>2</sub> , P <sup>t</sup> -Bu <sub>2</sub> Me, KO <sup>t</sup> -Bu, TAA, 60 °C, 18 h |        | no conversion       |
| 12    | CuI, LiO <sup>t</sup> -Bu, THF, rt, 18 h   |        | no conversion       |
| 13    | CuI, LiO <sup>t</sup> -Bu, DMF, 60 °C, 18 h  |        | traces              |

<sup>a</sup> MW-irrad. = microwave-irradiation; dme = dimethoxyethane; TAA = *t*-amyl alcohol

<sup>b</sup> **168** was the main product in each reaction that showed conversion ( $\beta$ -hydride elimination)

ligands:

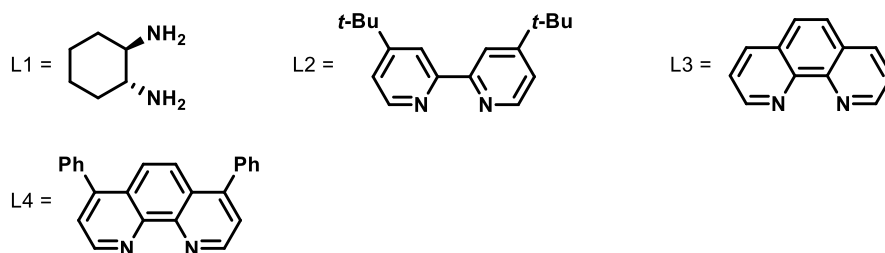

**Scheme 47:** Screening table for C(sp<sup>2</sup>)-(sp<sup>3</sup>) coupling conditions of model substrates **128** and **164**.

Boronic acids are more reactive towards transmetalation than boronic esters. This is due to the  $\sigma$ -donor ability of carbon, resulting in an increased hyperconjugation of the oxygen lone pairs to the electron-deficient boron center. Therefore, commercial 3-methoxyphenylboronic acid (**169**) was subjected to the conditions of entry 8 in Scheme 47, resulting in the formation of the coupled product, but only in slightly increased yield of 12%, with alkene **168** being the major product (Scheme 48).

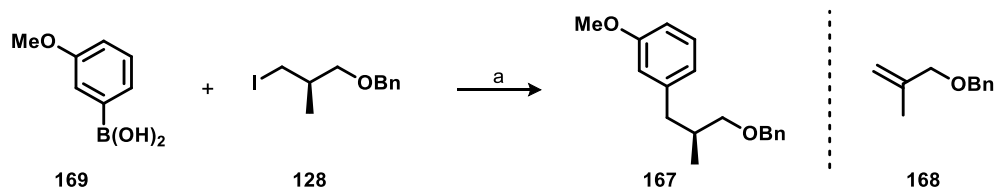

**Scheme 48:** Suzuki coupling of 3-methoxyphenylboronic acid (**169**) with alkyl iodide **128**. The  $\beta$ -hydride elimination product **168** was the major product. Conditions: a) Ni(cod)<sub>2</sub>, KO*t*-Bu, 2-butanol, 120 °C, microwave-irradiation, 20 min, 12%.

Since no suitable conditions were found for the Suzuki coupling with primary alkyl iodide **128**, the strategy was changed. Instead of using the alkyl halide in the coupling, it should be converted to its corresponding boronic ester and coupled with aryl bromide **166**. Treatment of iodide **128** with *t*-BuLi and pinBO*i*-Pr in Et<sub>2</sub>O provided desired boronic ester **170**, but in low yields. Applying a copper-catalyzed borylation method as published by Liu *et al.*<sup>[139]</sup> gave rise to the boronic ester in acceptable yield (Scheme 49). The subsequent Suzuki coupling was again unsuccessful under different conditions<sup>[138,139,146,147]</sup>, providing alkene **168** as the sole product.

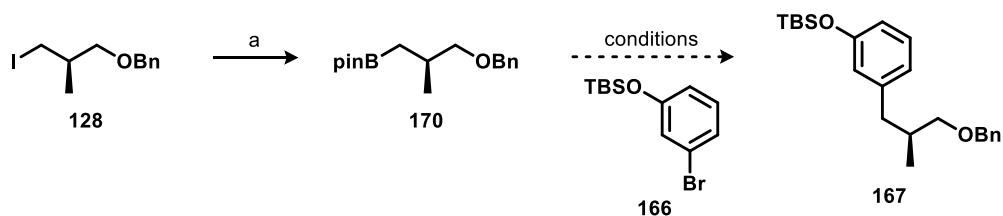

| entry | conditions <sup>a</sup>  | ligand | result        |
|-------|--|--------|---------------|
| 1     | Pd <sub>2</sub> (dba) <sub>3</sub> , NaO <i>t</i> -Bu, PhMe/H <sub>2</sub> O (10:1), 80 °C, 24 h                       | RuPhos | no conversion |
| 2     | CuI, LiO <i>t</i> -Bu, THF, rt, 18 h   |        | no conversion |
| 3     | CuI, LiO <i>t</i> -Bu, DMF, 60 °C, 18 h  |        | no conversion |
| 4     | Pd(dppf)Cl <sub>2</sub> •CH <sub>2</sub> Cl <sub>2</sub> , KOAc, 1,4-dioxane, 120 °C, 20 min, MW-irrid.                |        | no conversion |
| 5     | Pd(OAc) <sub>2</sub> , KO <i>t</i> -Bu, PhMe/H <sub>2</sub> O (10:1), 80 °C, 18 h                                      | RuPhos | no conversion |
| 6     | Pd <sub>2</sub> (dba) <sub>3</sub> , K <sub>3</sub> PO <sub>4</sub> , 1,4-dioxane/H <sub>2</sub> O (2:1), 100 °C, 18 h | Q-Phos | no conversion |

<sup>a</sup> MW-irrid. = microwave-irradiation; dba = dibenzylidenacetone; dppf = 1,1'-bis(diphenylphosphino)ferrocene

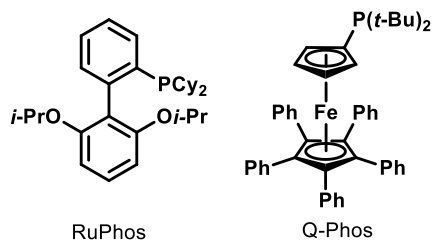

**Scheme 49:** Copper-catalyzed borylation of alkyl iodide **128** and unsuccessful subsequent Suzuki coupling. Conditions: a) CuI, LiO*t*-Bu, B<sub>2</sub>pin<sub>2</sub>, THF, rt, 22 h, 45%.

In view of the moderate yield of the borylation and the fact that in the reported procedures for coupling the boronic acid ester had to be used in great excess, further attempts to introduce the arene via Suzuki coupling were discontinued.

Alternatively, the direct coupling of an aryl halogenide with an alkyl halogenide was envisaged by a Kumada reaction.<sup>[148]</sup> This method is used to generate carbon-carbon bonds by reaction of a Grignard reagent and an organic halide under transition metal catalysis. In recent years, protocols using iron-based catalysts have proven to be very efficient.<sup>[149]</sup> Iron offers several advantages over other transition metals because it is cheap, non-toxic, readily available, and rich in oxidation states. Wangelin and co-workers described a magnesium-mediated direct cross-coupling between aryl halides and alkyl halides, in which they used FeCl<sub>3</sub> as catalyst.<sup>[150]</sup> This protocol was successfully adapted earlier in our group in the total synthesis of Noricumazol A.<sup>[151]</sup> Since the coupling was reported to work better with phenols protected as its MOM ether instead of its TBS ether, aryl bromide **171** was synthesized. In the subsequent coupling with alkyl iodide **128**, product **172** could be detected by mass analysis, but the coupling could not be carried out in isolable yields (Scheme 50).

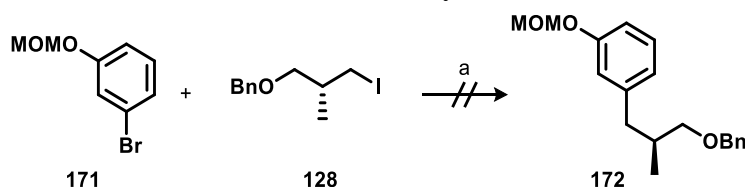

**Scheme 50:** Kumada coupling of aryl bromide **171** and alkyl iodide **128**. Conditions: a) Mg, THF, 70 °C, 1 h, then **128**, HMTA, TMEDA, Fe(acac)<sub>3</sub>, 0 °C, 1.5 h.

Eager to pursue the idea of a direct cross-coupling further, alternative conditions were investigated. Weix *et al.* reported a nickel-catalyzed reductive alkylation of aryl bromides.<sup>[143]</sup> Interestingly, the authors claim a high degree of functional group tolerance. In fact, aryl bromides bearing acidic groups such as –OH and –NH<sub>2</sub>Boc were successfully coupled. Based on these results Shen *et al.* slightly modified Weix's method to react aryl bromide **173** with alkyl bromide **174** delivering the coupling product **175** in 60% yield (Scheme 51).<sup>[142]</sup>

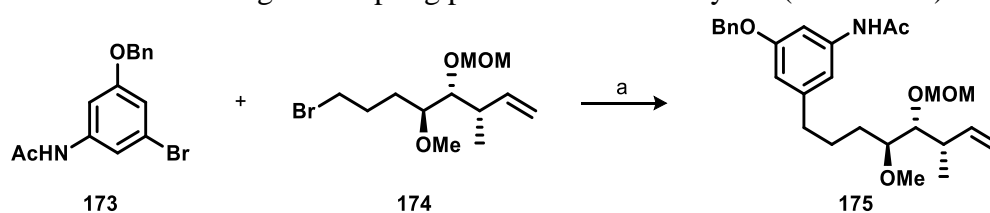

**Scheme 51:** Nickel-catalyzed reductive alkylation of aryl bromide **173** with alkyl bromide **174** published by Shen *et al.*<sup>[142]</sup> Conditions: a) 20% Ni(cod)<sub>2</sub>, 20% 2,2'-Bipyridine, 2.0 eq. Zn, 25% NaI, 10% pyridine, DMPU, 60 °C, 4 days, 60%.

Given the high similarity of the substrates this method appeared highly promising. Screening of a short series of different bromoarenes should deliver insights regarding suitable protecting groups for the phenol and the aniline. Arenes **176-178** were chosen as candidates together with alkyl bromide **179** as a model system (Scheme 52). The alkyl bromide was prepared from aforementioned alcohol **125** by an Appel reaction using NBS and PPh<sub>3</sub> in CH<sub>2</sub>Cl<sub>2</sub> at room temperature in 76% (87% brsm) yield. The synthesis of the bromo arenes commenced with bromination of 2-amino-5-nitrophenol (**180**) followed by diazotization furnishing 3-bromo-5-nitrophenol (**181**). Béchamp reduction of the nitro group using iron powder and acetic acid gave rise to 3-amino-5-bromophenol (**182**).<sup>[152]</sup> *tert*-Butoxycarbonyl (Boc)

protection of the aniline under standard conditions ( $\text{Boc}_2\text{O}$  (1.0 eq.) in THF/sat. aq.  $\text{NaHCO}_3$  (1:4), rt) resulted in the formation of a mixture of *N*-protected and *O*-protected products providing the desired product only in 53% yield. Following a protocol published by Shinde *et al.*<sup>[153]</sup> and treating the aniline with  $\text{Boc}_2\text{O}$  in glycerol at room temperature gave carbamate **183** in quantitative yield without the necessity of any purification steps. The phenol could then be converted into silyl ether **176** or benzyl ether **177** under standard conditions with TBSCl and imidazole or benzyl bromide and  $\text{K}_2\text{CO}_3$ , respectively. The phenol could also be protected under the same conditions in presence of the free aniline without any decrease in yield furnishing **184** which was then acetylated to give acetamide **178** in excellent yield.

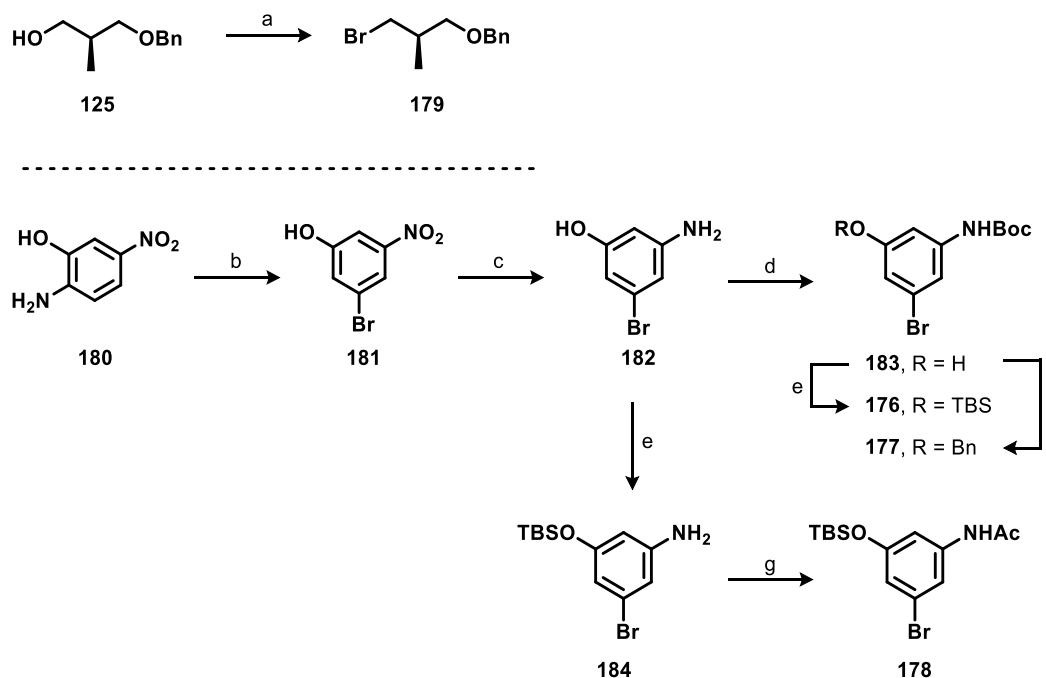

**Scheme 52:** Synthesis of test substrates for nickel-catalyzed reductive alkylation of aryl bromides. Conditions: a) NBS,  $\text{PPh}_3$ ,  $\text{CH}_2\text{Cl}_2$ , rt, o/n, 76% (87% brsm); b) NBS, MeCN (wet), rt, 1 h, then  $\text{H}_2\text{SO}_4$  (conc.), EtOH (wet), reflux., 30 min, then  $\text{NaNO}_2$ , reflux., 1 h, 58%; c) AcOH, Fe (powder), EtOH, reflux., 2 h, 81%; d)  $\text{Boc}_2\text{O}$ , glycerol, rt, 18 h, *quant.*; e) TBSCl, imidazole,  $\text{CH}_2\text{Cl}_2$ , rt, for **176**: 2 h, 75%, for **184**: 48 h, 75%; f) BnBr,  $\text{K}_2\text{CO}_3$ , acetone, 70 °C, 48 h, 93%; g) Ac<sub>2</sub>O, pyridine,  $\text{CH}_2\text{Cl}_2$ , rt, 30 min, 90%.

With the three bromoarenes **176-178** and alkyl bromide **179** in hand, the reductive coupling was carried out under the same conditions as in Shen's method on a 60  $\mu\text{mol}$  scale. The analysis was carried out by GCMS without isolation of the products and determination of the yields, since this screening was intended only to verify the method and the suitability of the selected protecting groups. With all three arenes product formation was observed along with some elimination product. Since the TBS protection group for the phenol is best in line with the global protection group strategy, bromo arene **176** was chosen for further optimization (Scheme 53). Increasing the scale by twofold allowed purification and isolation of the products. After stirring for 4 days at 60 °C using the exact same conditions as Shen, the starting material was not completely consumed, and NMR analysis revealed a 3:1 mixture of product (**185**) and elimination product (**168**) that could not be separated. The corrected yield for the coupling product was 19% (entry 1). Any change in catalyst loading, amount of ligand used or the equivalents of zinc as reducing agent resulted in yield losses (entries 2 to 4). Premixing the precatalyst with the ligand for 2 h at 60 °C in DMPU did not have any positive effect on the result (entry 5). Extending the reaction time to 7 days resulted in increased



formation of  $\beta$ -elimination without improved product formation (entry 6) as judged by crude NMR spectroscopic analysis.

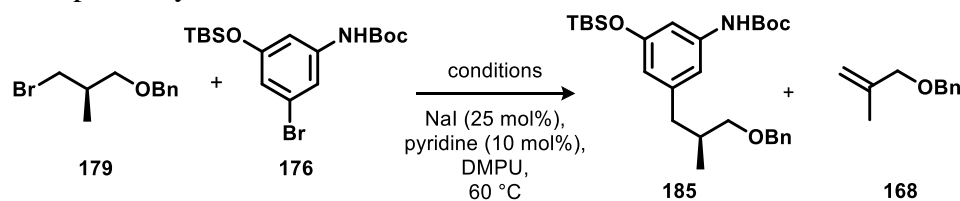

| entry          | conditions                  |                       |          | result                      |
|----------------|-----------------------------|-----------------------|----------|-----------------------------|
|                | Ni(cod) <sub>2</sub> (mol%) | 2,2'-bipyridyl (mol%) | Zn (eq.) |                             |
| 1              | 20                          | 10                    | 2        | 19%, <b>185:168</b> = 3:1   |
| 2              | 30                          | 10                    | 2        | 15%, <b>185:168</b> = 3:1   |
| 3              | 20                          | 20                    | 2        | 11%, <b>185:168</b> = 3:1   |
| 4              | 20                          | 10                    | 3        | 9%, <b>185:168</b> = 3:1    |
| 5 <sup>a</sup> | 20                          | 10                    | 2        | 19%, <b>185:168</b> = 3:1   |
| 6 <sup>b</sup> | 20                          | 10                    | 2        | 17%, <b>185:168</b> = 2.3:1 |

<sup>a</sup> Ni(cod)<sub>2</sub> and 2,2'-bipyridyl were stirred in DMPU at 60 °C for 2 h before adding the substrates and other reagents.

<sup>b</sup> Reaction was stirred for 7 days.

**Scheme 53:** Model system for nickel-catalyzed reductive alkylation of aryl bromide **176** with alkyl bromide **179**.

Despite these significantly inferior results compared to those of Shen, this method was transferred from the model system to the target molecule. The required alkyl bromide **186** could be synthesized by an Appel reaction from alcohol **187** which would be readily accessible after debenzylation from benzyl ether **134**. Cleavage of the primary benzyl ether, however, could not be achieved by simple hydrogenation, one of the predominant methods for cleavage of benzyl ethers, due to the presence of the alkyne. Therefore, other methods were investigated (Scheme 54). First, BBr<sub>3</sub> in CH<sub>2</sub>Cl<sub>2</sub> was employed at -78 °C, which led only to trace amounts of the product, while the starting material was recovered. Increasing the temperature to 0 °C did not change this result (entries 1 and 2). It was found that different batches of BBr<sub>3</sub> varied in reactivity, as in some cases not even traces of the product were detected (data not shown). Therefore, the more stable dimethyl sulfide complex was used instead. When used in excess (4.0 eq.) at 0 °C for 30 min, the primary alcohol was obtained in 5% yield based on recovered starting material (entry 3). Extending the reaction time or raising the temperature, however, led to decomposition of the material (entries 4 and 5). A mixture of demethylated and desilylated products was determined by LCMS. As a milder method, it has been reported that TiCl<sub>4</sub> can cleave benzyl ethers when used in catalytic amounts at 0 °C in CH<sub>2</sub>Cl<sub>2</sub>.<sup>[154]</sup> However, even in excess only the starting material was recovered (entries 6 to 8). Finally, when the cleavage was carried out under Birch conditions using a solution of lithium 4,4'-di-*tert*-butylbiphenylide<sup>[155]</sup> (LiDBB) in THF at room temperature complete consumption of the starting material could be observed and the product could be isolated in 40% yield. At this temperature, reduction of the alkyne to the alkene was observed (entry 9). By lowering the temperature, the formation of alkene was avoided and the yield was increased to 66% at

0 °C and 83% at -78 °C, respectively (entries 10 and 11). The reaction times are not given in the table in Scheme 54, since the reaction was carried out as a titration. Persistence of a deep blue color indicated the completion of the reaction.

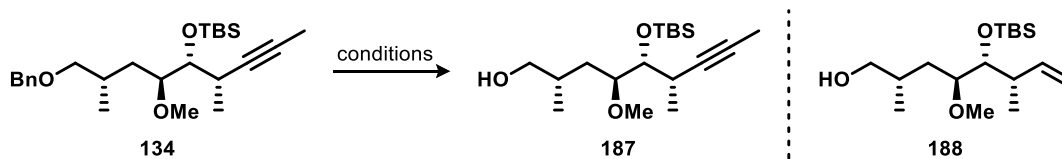

| entry | conditions   | result                               |
|-------|--|--------------------------------------|
| 1     | BBr <sub>3</sub> (1.2 eq.), CH <sub>2</sub> Cl <sub>2</sub> , -78 °C, 30 min                 | traces of product, SM recovered      |
| 2     | BBr <sub>3</sub> (1.2 eq.), CH <sub>2</sub> Cl <sub>2</sub> , 0 °C, 30 min                   | traces of product, SM recovered      |
| 3     | BBr <sub>3</sub> ·SMe <sub>2</sub> (4.0 eq.), CH <sub>2</sub> Cl <sub>2</sub> , 0 °C, 30 min | 5% (brsm)                            |
| 4     | BBr <sub>3</sub> ·SMe <sub>2</sub> (4.0 eq.), CH <sub>2</sub> Cl <sub>2</sub> , 0 °C, 2 h    | decomposition                        |
| 5     | BBr <sub>3</sub> ·SMe <sub>2</sub> (4.0 eq.), CH <sub>2</sub> Cl <sub>2</sub> , rt, 20 min   | decomposition                        |
| 6     | TiCl <sub>4</sub> (0.01 eq.), CH <sub>2</sub> Cl <sub>2</sub> , 0 °C to rt, 2 h              | recovered SM                         |
| 7     | TiCl <sub>4</sub> (0.1 eq.), CH <sub>2</sub> Cl <sub>2</sub> , 0 °C to rt, 2 h               | recovered SM                         |
| 8     | TiCl <sub>4</sub> (1.5 eq.), CH <sub>2</sub> Cl <sub>2</sub> , 0 °C to rt, 2 h               | recovered SM                         |
| 9     | LiDBB (2.5 eq.), THF, rt   | 40%, alkene ( <b>188</b> ) formation |
| 10    | LiDBB (2.5 eq.), THF, 0 °C   | 66%                                  |
| 11    | LiDBB (2.5 eq.), THF, -78 °C   | 83%                                  |

**Scheme 54:** Benzyl ether cleavage of **134**.

Against the expectations the subsequent Appel reaction was relatively low yielding (Scheme 55). Using NBS and PPh<sub>3</sub> yielded bromide **186** in modest yield (entry 1).

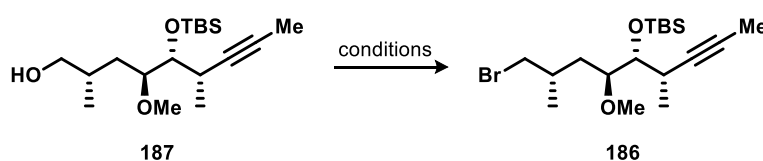

| entry | conditions  | result                        |
|-------|---|-------------------------------|
| 1     | NBS, PPh <sub>3</sub> , CH <sub>2</sub> Cl <sub>2</sub> , rt, o/n   | 42% (58% brsm)                |
| 2     | CBr <sub>4</sub> , PPh <sub>3</sub> , CH <sub>2</sub> Cl <sub>2</sub> , 0 °C to rt, o/n                   | 42% (62% brsm)                |
| 3     | CBr <sub>4</sub> , PPh <sub>3</sub> , imidazole, CH <sub>2</sub> Cl <sub>2</sub> , 40 °C, 6 h             | 67%                           |
| 4     | 1) Et <sub>3</sub> N, MsCl, CH <sub>2</sub> Cl <sub>2</sub> , 0 °C to rt, 6 h<br>2) LiBr, DMF, 65 °C, 5 h | recovered SM,<br>desilylation |
| 5     | 1) Et <sub>3</sub> N, TsCl, CH <sub>2</sub> Cl <sub>2</sub> , 0 °C to rt, 6 h<br>2) LiBr, DMF, 65 °C, 5 h | recovered SM,<br>desilylation |

**Scheme 55:** Appel reaction of alcohol **187** furnishing bromide **186**.

Under standard conditions using  $\text{CBr}_4$  and  $\text{PPh}_3$  at room temperature overnight, the bromide was also obtained, but only in 42% yield (entry 2). The addition of imidazole and increasing the temperature to 40 °C was beneficial, providing bromide **186** in 67% yield (entry 3). Mesylation or tosylation of the alcohol, followed by Finkelstein reaction with  $\text{LiBr}$  at 65 °C did not furnish the bromide. Instead, the starting material was recovered together with the desilylated homopropargylic alcohol (entries 4 and 5).

With alkyl bromide **186** in hand, the reductive coupling was carried out using aryl bromides **176-178** under the above conditions, but did not provide the desired product (Scheme 56). After 5 days at 60 °C, TLC-analysis showed only the starting materials. The reaction was carried out on a relatively small scale (10  $\mu\text{mol}$ ) and it was assumed that the lower concentration of the reaction compared to the model system (0.06 M vs. 0.2 M regarding the alkyl bromide) may have been problematic. Therefore, the concentration was increased to 0.17 M by using a MS-tube (500  $\mu\text{l}$ ) as the reaction vessel, which allowed small volumes and still ensured good stirring.

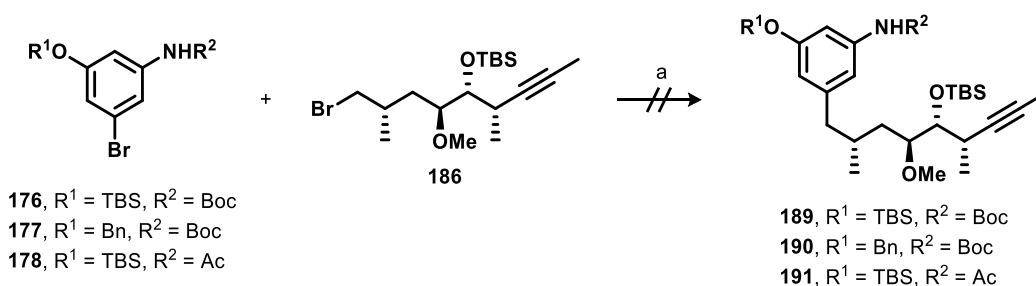

**Scheme 56:** Unsuccessful nickel-catalyzed direct coupling of aryl bromides **176** to **178** with alkyl bromide **186**. Conditions: a)  $\text{Ni}(\text{cod})_2$  (20 mol%), 2,2'-bipyridyl (10 mol%),  $\text{Zn}$  (2.0 eq.),  $\text{NaI}$  (25 mol%), pyridine (10 mol%), DMPU, 60 °C, 7 days.

Unfortunately, this adjustment did not improve the outcome of the reaction. Stirring was continued for several days, without any product formation. Instead, after 7 days the elimination product began to form as indicated by LCMS-analysis.

### 3.3.5.2 Lithiation-Borylation-Protodeboration

With pinacol boronic ester **164** already in hand introduction of the arene by a lithiation-borylation-protodeboration approach was envisaged. Primary 2,4,6-triisopropylbenzoates (TIB) are well suited for this purpose, as they are known to be readily subjected to  $\alpha$ -lithiation by treatment with *s*-BuLi, and subsequent reaction with boronic esters yields boronate complexes that rapidly undergo 1,2-metallate rearrangement to provide the homologated products.<sup>[156]</sup> For the protodeboration of boronic esters, the use of  $\text{TBAF} \cdot 3\text{H}_2\text{O}$  is described as a common and simple method.<sup>[157]</sup> Since the protection group strategy at this time is based on silyl protecting groups, desilylation would naturally occur if TBAF were used. This could be used as an advantage. If the arene would be introduced towards the end of the synthesis, the protodeboration and global deprotection could be achieved in one step. Therefore, no change in protection groups was intended at this point. Alkyne **192**, which was available at this time in a sufficient amount, was chosen as a test substrate. These were residual amounts of the undesirable diastereomer of the Marshall propargylation, which could be separated after protection of the homopropargylic alcohol and served no further purpose. After Birch reduction, the benzoate was successfully introduced by Mitsunobu reaction using 2,4,6-

triisopropylbenzoic acid (TIBOH) with DIAD and PPh<sub>3</sub> in acceptable yields (Scheme 57). Direct acylation with TIBCl was also investigated, which lead to comparably lower yields. For the subsequent borylation, benzoate **193** was treated with *s*-BuLi in presence of TMEDA in Et<sub>2</sub>O for 5 h, followed by addition of boronic ester **164**. Since aryl groups are poor migrating groups<sup>[156]</sup>, a solvent exchange from Et<sub>2</sub>O to CHCl<sub>3</sub> was necessary after boronate complex formation to promote the 1,2-shift.<sup>[158,159]</sup> The expected homologation product **194** was detected by HRMS and NMR-spectroscopy along with the starting materials. Unfortunately, chromatographic separation of the homologation product from the starting materials was not possible with different eluent systems. Furthermore, the desired product was only a minor component of this mixture. Nevertheless, the protodeboronation with TBAF·3H<sub>2</sub>O was performed with the impure mixture. Typically, TBAF·3H<sub>2</sub>O is used in small excess (1.5 eq.) for protodeboronations. Since the impure mixture was used, the moles of TBS groups in the mixture were considered and the amount of TBAF was adjusted accordingly. Since the arylboronic ester was used in the borylation step in 1.5-fold excess, the theoretical amount of fluoride-scavenging groups in the mixture is 4.5 equivalents. Therefore, benzoate **194** was treated with 6.75 eq. of TBAF·3H<sub>2</sub>O in PhMe under refluxing conditions. After stirring for 5 h the desilylated protodeboronation adduct **195** could be detected by HRMS but could not be isolated in usable amounts.

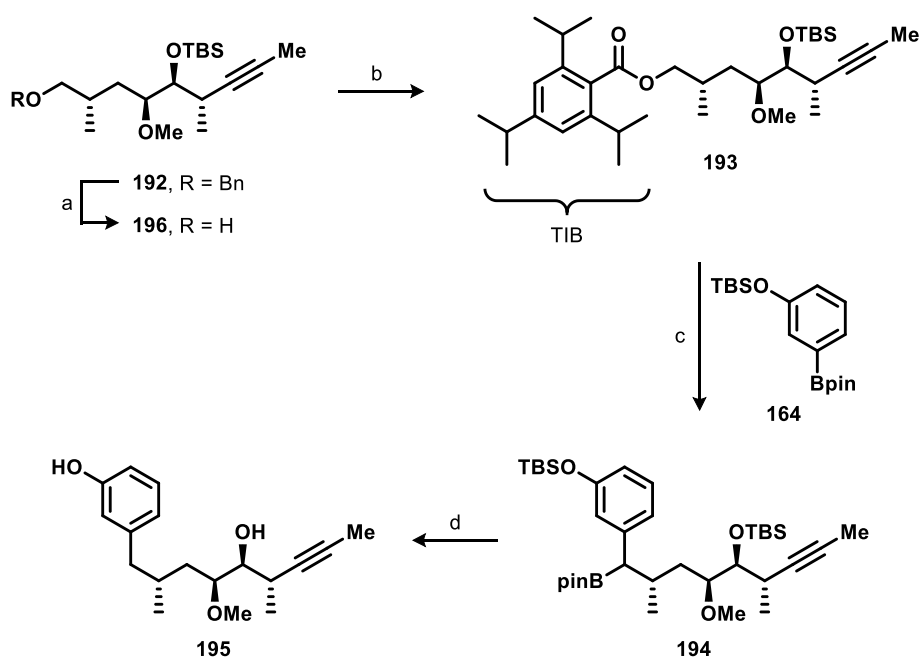

**Scheme 57:** Lithiation-borylation-protodeboronation approach. Conditions: a) LiDBB, THF, -78 °C, 30 min, 80%; b) TIBOH, PPh<sub>3</sub>, DIAD, THF, 0 °C, o/n, 53%, 89% brsm; c) *s*-BuLi, TMEDA, Et<sub>2</sub>O, -78 °C, 5 h, then **164**, -78 °C, 2.5 h, then solvent exchange, CHCl<sub>3</sub>, reflux., o/n, yield n.d.; d) TBAF·3H<sub>2</sub>O, PhMe, reflux., 5 h, yield n.d., only detected by HRMS.

Due to the purification problems associated with the low performance of the homologation, and because of the mediocre yields of the Mitsunobu reaction this approach was not pursued further. In fact, a different strategy based on a 1,2-addition followed by deoxygenation was carried out in parallel to the above experiments and appeared more promising (*vide infra*).

### 3.3.5.3 1,2-Addition and Deoxygenation

The 1,2-addition was envisaged by lithiation of an aryl bromide and addition to aldehyde **197**, which was readily available from alcohol **187** by oxidation using DMP and NaHCO<sub>3</sub> in 90% yield (Scheme 58).

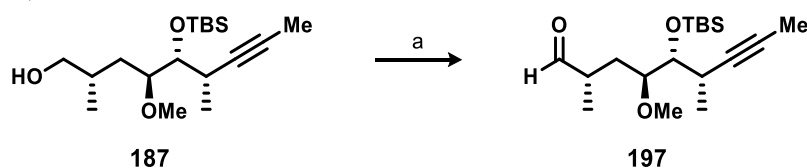

**Scheme 58:** Oxidation of alcohol **187**. Conditions: a) NaHCO<sub>3</sub>, DMP, 0 °C to rt, CH<sub>2</sub>Cl<sub>2</sub>, 2 h, 90%.

Lithiation of the aryl bromide should be achieved by treatment with *t*-BuLi which requires the *N*-bis-protected aniline. Therefore, a second Boc group should be installed at mono-protected aniline **176**. Due to the reduced nucleophilicity of the carbamate this transformation is likely to be more challenging than the aforementioned mono-Boc protection.

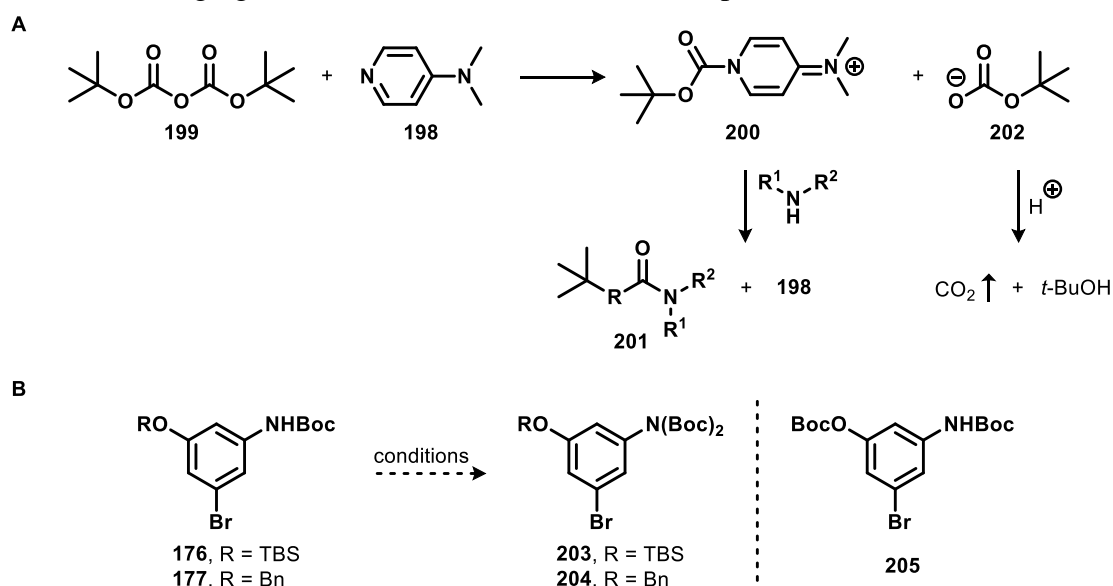

| entry | R   | conditions   | result                               |
|-------|-----|--|--------------------------------------|
| 1     | TBS | Boc <sub>2</sub> O (1.0 eq.), DMAP (0.1 eq.), MeCN, rt, 24 h                                 | no conversion                        |
| 2     | TBS | Boc <sub>2</sub> O (1.0 eq.), DMAP (0.1 eq.), MeCN, 45 °C, 24 h                              | no conversion                        |
| 3     | TBS | Boc <sub>2</sub> O (2.0 eq.), DMAP (0.1 eq.), MeCN, rt, 24 h                                 | no conversion                        |
| 4     | TBS | Boc <sub>2</sub> O (2.0 eq.), DMAP (0.1 eq.), MeCN, 45 °C, 24 h                              | no conversion                        |
| 5     | TBS | Boc <sub>2</sub> O (1.0 eq.), DMAP (0.1 eq.), Et <sub>3</sub> N (1.0 eq.), THF, reflux., 5 h | <b>176</b> + <b>205</b> <sup>a</sup> |
| 6     | TBS | Boc <sub>2</sub> O (1.0 eq.), DMAP (0.1 eq.), Et <sub>3</sub> N (1.0 eq.), THF, rt, 5 h      | <b>176</b> + <b>205</b> <sup>a</sup> |
| 7     | Bn  | Boc <sub>2</sub> O (1.0 eq.), DMAP (0.1 eq.), Et <sub>3</sub> N (1.0 eq.), THF, reflux., 5 h | no conversion                        |
| 8     | Bn  | Boc <sub>2</sub> O (1.0 eq.), DMAP (0.1 eq.), Et <sub>3</sub> N (1.0 eq.), THF, rt, 5 h      | no conversion                        |

<sup>a</sup> inseparable, yield not determined

**Scheme 59:** **A**) The Boc-DMAP complex (**200**) and its reaction with secondary amines. **B**) Attempted bis-Boc protection of carbamated **176** and **177**.

Indeed, simply using the same conditions that were evaluated for the synthesis of **176** with an excess of  $\text{Boc}_2\text{O}$  did not result in bis-protection of the aniline. The principle of nucleophilic catalysis could be a solution here. The use of catalytic amounts of DMAP (**198**) together with  $\text{Boc}_2\text{O}$  (**199**) results in the formation of a *N*-Boc-DMAP complex (**200**, Scheme 59, A). This intermediary complex displays greater electrophilicity compared with the anhydride. Reaction with an amine will furnish the carbamate **201**. Furthermore, the release of  $\text{CO}_2$  gas from *tert*-butoxylate (**202**) acts as driving force. This methodology has been successfully applied in different dual protections of amino functions.<sup>[160]</sup> Accordingly, carbamate **176** was treated with  $\text{Boc}_2\text{O}$  and DMAP in MeCN both at room temperature and at elevated temperature and also with an excess of  $\text{Boc}_2\text{O}$ . Yet, no conversion was observed and the starting material was recovered (Scheme 59, B, entries 1 to 4). When  $\text{Et}_3\text{N}$  was additionally added and the reaction was carried out in THF under refluxing conditions<sup>[161]</sup>, the TBS group was partially removed resulting in a mixture of *N,O*-di-Boc protected arene **205** and starting material (entry 5). At room temperature the TBS ether was also cleaved resulting in the same complex mixture as above (entry 6). When the more stable benzyl ether **177** was used instead of the silyl ether, deprotection of the phenol did not occur. Unfortunately, *N*-bis-Boc protection did not take place either and the starting material was recovered (entries 7 and 8).

In a comprehensive study, Basel and Hassner evaluated the reaction of  $\text{Boc}_2\text{O}$ -DMAP with different amines and anilines.<sup>[162]</sup> Interestingly, the only substrate that gave the *N*-bis-Boc adduct, was *o*-nitroaniline when treated with  $\text{Boc}_2\text{O}$ -DMAP at room temperature in PhMe. Reaction of aniline **184** under these conditions, however, provided the mono-protected aniline together with urea **206** (Scheme 60).

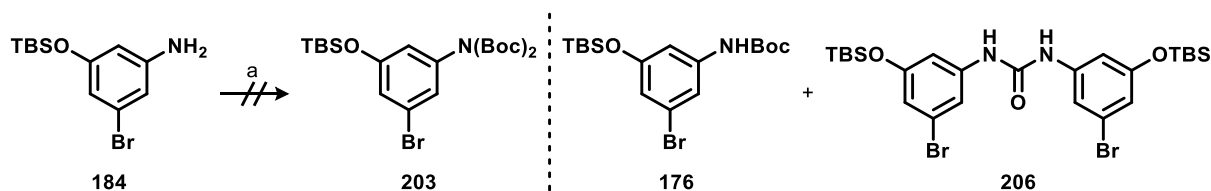

**Scheme 60:** Unsuccessful di-Boc protection of aniline **184** using  $\text{Boc}_2\text{O}$ -DMAP. Carbamate **176** and urea **206** was obtained. Conditions: a)  $\text{Boc}_2\text{O}$ , DMAP, PhMe, rt, 6 h.

The mechanistic aspects of the formation of urea by-product **206** are explained in Scheme 61.<sup>[162–164]</sup> As mentioned above, the reaction of  $\text{Boc}_2\text{O}$  with DMAP, which occurs almost instantaneously, produces complex **200** and *tert*-butoxylate (**203**). The latter releases *tert*-butoxide (**207**) and  $\text{CO}_2$ . Under these basic conditions primary amines react with  $\text{CO}_2$  to give a carbamate **208**. This carbamate can react with Boc-pyridinium species **200** to give carbamic-carbonic anhydride **209** as the key intermediate. This step is similar to the reaction of carboxylates with alkyl chloroformates providing mixed anhydrides.<sup>[165]</sup> There are now three possible ways for the formation of urea **210**. Attack of the amine on the carbamic carbonyl would furnish the urea directly (path A). However, attack on the carbonic carbonyl is expected to be more favorable, affording the *N*-Boc protected amine. Alternatively, decomposition of the carbamic-carbonic anhydride with release of  $\text{CO}_2$  would furnish isocyanate **211**, which can react with the amine to give the urea (path B). Lastly, DMAP can attack the carbamic carbonyl resulting in the formation of complex **212**. Attack of the amine with release of DMAP would then furnish the urea as well (path C).

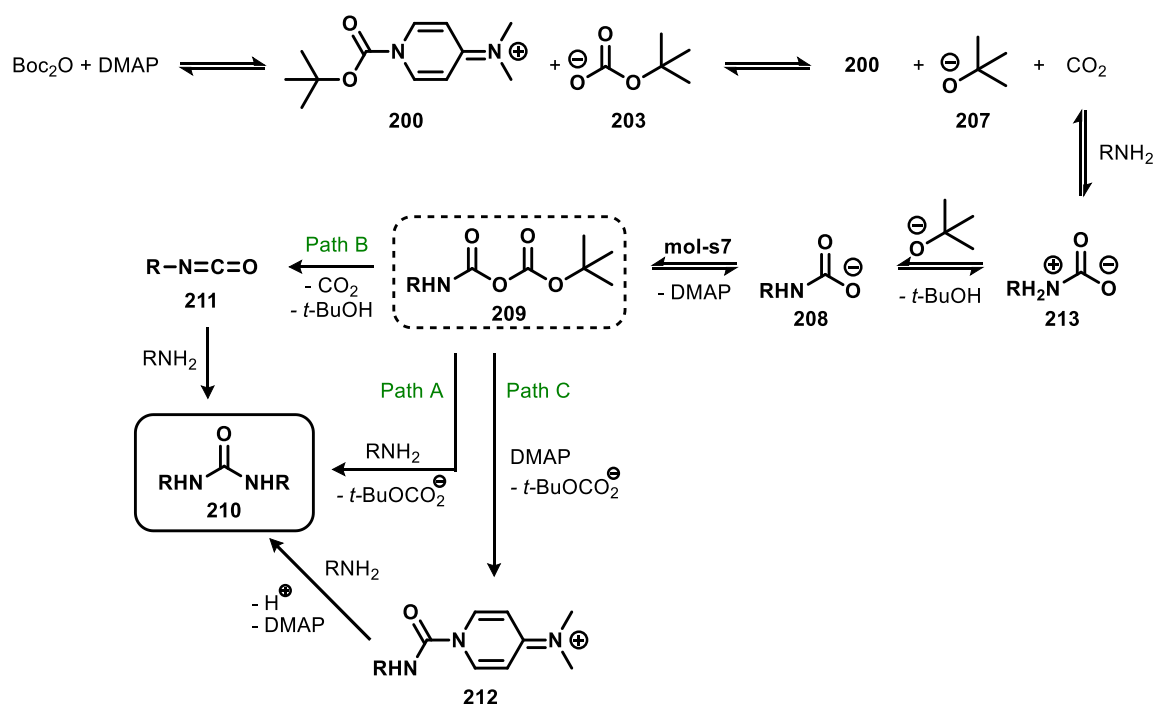

**Scheme 61:** Mechanistic aspects of urea formation after reaction of primary amines with Boc<sub>2</sub>O-DMAP.<sup>[162]</sup>

Since the di-Boc protection strategy was not suitable, other protection groups that would allow a bis-protection of the aniline were considered. A rather uncommon protection group for primary amines is masking as 2,5-dimethylpyrrol, which is accessible by a Paal-Knorr synthesis from the aniline with 2,5-hexadione. However, cleavage of the pyrrole would require rather harsh conditions by using hydroxylamine hydrochloride with KOH under refluxing conditions. Since previous studies in our group by Marco Brünjes have shown that this protection strategy is quite problematic, it was not considered further.<sup>[166]</sup> Protection as the corresponding phthalimide would not be possible either due to the instability of this group to nucleophilic reagents. Instead, the aniline was treated with 1,2-bis(chlorodimethylsilyl)ethane, Et<sub>3</sub>N and DMAP to give stabase-protected<sup>[167]</sup> aniline **214**, which would be stable under lithiation conditions but proved to be very acid labile (Scheme 62).

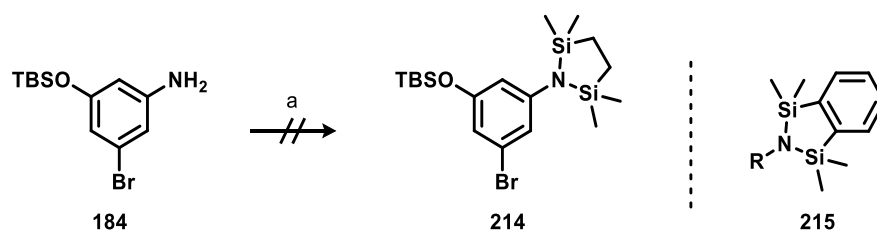

**Scheme 62:** Unsuccessful *N*-bisprotection of aniline **184** as stabase (**214**) due to acid lability upon purification. Conditions: a) 1,2-bis(chlorodimethylsilyl)ethane, Et<sub>3</sub>N, DMAP, CH<sub>2</sub>Cl<sub>2</sub>, rt, 3 h.

Purification by flash column chromatography using silica gel was not possible. The stability of the N-Si bond was found to be strongly dependent on the polarity of the eluent. Some stabase derivatives were reported to be stable to silica gel with a 1:1-mixture of hexane/ether as eluent but decompose when the polarity was decreased to 5:1.<sup>[168]</sup> Here, product **214** already decomposed using quite polar eluents (1:2 hexane/ether). Basic alumina did not provide a good separation, and furthermore, even trace amounts of acid in the CDCl<sub>3</sub> used for

NMR measurements caused cleavage of the stabase. The same stability problems have been reported for the actually more stable benzostabase (**215**, Scheme 62).<sup>[168]</sup> Therefore, the use of the latter was not considered.

Next, the *N*-bis-allyl protection of the aniline was examined. Aniline **184** was treated with allyl bromide and K<sub>2</sub>CO<sub>3</sub> in MeCN at 60 °C overnight, resulting in a mixture that could be hardly separated. Analysis showed that the mixture comprised of the desired *N*-bis-allyl protected aniline **216** in rather low yield, together phenol **217** and *N,N,O*-triallyl arene **218** (Scheme 63). To avoid cleavage of the silyl ether, the reaction was repeated at 40 °C, but the outcome was identical. At room temperature the TBS group remained intact, but bis-protection of the aniline was not feasible.

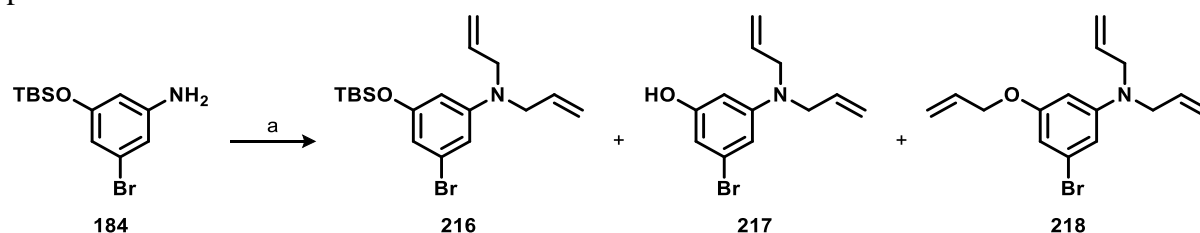

**Scheme 63:** Attempted *N*-bis-allyl protection of aniline **184**. Conditions: a) K<sub>2</sub>CO<sub>3</sub>, allyl bromide, MeCN, 60 °C, 18 h.

Although the TBS group was not stable under these conditions, the results were quite promising. In fact, the allyl phenol ether, that is, aforementioned *N,N,O*-triallyl arene **218**, would be an interesting alternative to the TBS-protected phenol. Therefore, 3-amino-5-bromophenol (**182**) was subjected to the above conditions, but allylation remained incomplete. Increased excess (10.0 eq.) of K<sub>2</sub>CO<sub>3</sub> and allyl bromide as well as an high reaction temperatures were required to achieve complete allylation and furnished *N,N,O*-triallyl arene **218** in good yield (Scheme 64).

With aldehyde **197** and aryl bromide **218** in hand, the 1,2-addition could be carried out (Scheme 65). Treatment of the aryl bromide with *t*-BuLi and subsequent addition of the aldehyde gave a rather unexpected complex mixture as judged by TLC-analysis. Mass spectrometry identified the expected product and two additional products.

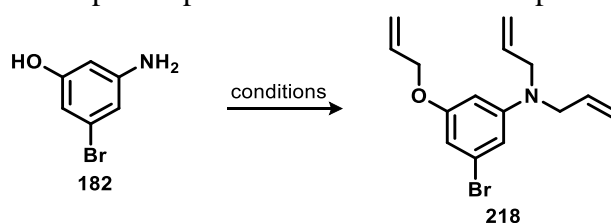

| entry | conditions   | result                |
|-------|--|-----------------------|
| 1     | K <sub>2</sub> CO <sub>3</sub> (5.0 eq.), allyl bromide (6.0 eq.), MeCN, 60 °C, 18 h   | incomplete allylation |
| 2     | K <sub>2</sub> CO <sub>3</sub> (5.0 eq.), allyl bromide (6.0 eq.), MeCN, 80 °C, 18 h   | incomplete allylation |
| 3     | K <sub>2</sub> CO <sub>3</sub> (10.0 eq.), allyl bromide (10.0 eq.), MeCN, 60 °C, 18 h | 88%                   |

**Scheme 64:** *N,N,O*-triallylation of 3-amino-5-bromophenol (**182**).

One of the by-products appeared to contain an additional allyl group, while the other by-product lacked an allyl group. After purification, the desired benzylic alcohol **219** could be isolated as a diastereomeric mixture in 35% yield (*d.r.* = 1:1).



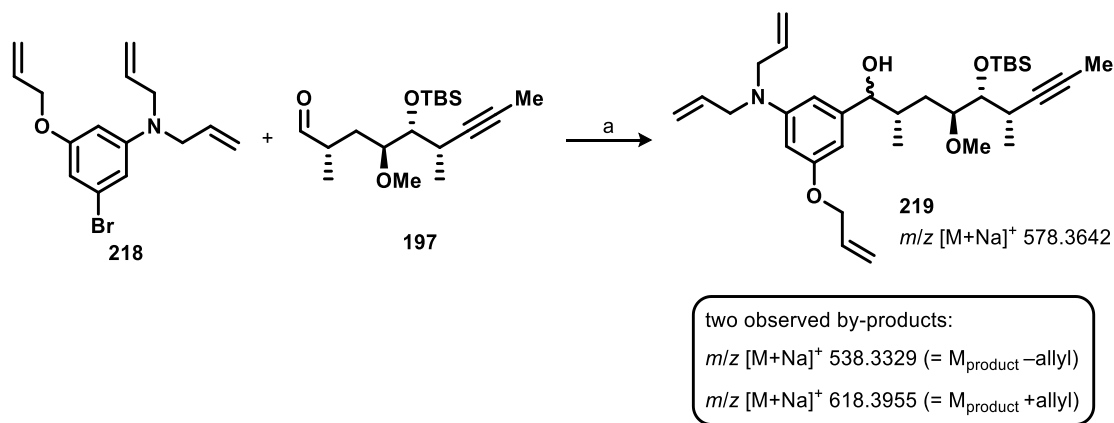

**Scheme 65:** 1,2-addition of aldehyde **197** and aryl bromide **218**. Two by-products were observed by HRMS analysis. One of these by-products contained an additional allyl group (i.e. 4 in total) while the other by-product lacked one allyl group (i.e. 2 in total). Conditions: a) *t*-BuLi, Et<sub>2</sub>O, -78 °C, 15 min, then **197**, -78 °C, 30 min, 35%, *d.r.* = 1:1.

While deprotection of the aniline was not observed according to the crude NMR-spectrum, one of the by-products could be isolated in sufficient quantity to perform NMR analysis, revealing the presence of a free phenolic proton. It was assumed that an allyl migration occurred due to the instability of the allyl group on the phenol. This migration could happen during the lithiation step. To verify the assumption, the lithiation was repeated on small scale and stopped after 15 minutes by addition of water. Mass analysis revealed the formation of three products (Scheme 66, A). Product **220** represents the protonated lithiate while **221** and **222** prove the migration of an allyl group. In context of the 1,2-addition, a proposed mechanism is depicted in Scheme 66 B. As the halogen lithium exchange is usually extremely fast and no residual aryl bromide was detected by mass analysis, it was assumed that the initial lithiation proceeded quantitatively. Then, lithiate **223** may react with a second lithiate in an intermolecular S<sub>N</sub>2 reaction, producing phenoxide **224** and intermediate **225**, which is prone to ortho-lithiation. Since *t*-BuLi was used in excess, lithiate **226** could be formed which then reacts with the aldehyde furnishing by-product **227**. Lastly, the phenoxide could also react with the aldehyde giving rise to by-product **228**. The by-products were not further analyzed and despite the instability of the phenolic allyl group, the envisaged synthesis was continued with available benzylic alcohol **219**. A different protection group should be introduced later.

The next step was a Barton-McCombie deoxygenation to excise the benzylic alcohol group (Scheme 67). Therefore, the corresponding methyl xanthate of alcohol **219** was prepared by treatment of the alcohol with NaHMDS and CS<sub>2</sub> followed by methylation with MeI. The subsequent deoxygenation was achieved by treatment of the methyl xanthate with a catalytic amount of Et<sub>3</sub>B, Bu<sub>3</sub>SnH and air. Et<sub>3</sub>B serves as the initiator in the radical reaction by providing alkyl radicals through auto oxidation with molecular oxygen. The alkyl radicals react with Bu<sub>3</sub>SnH providing stannyl radicals which in turn react with the methyl xanthate eventually furnishing the deoxygenated product. Under these conditions, the desired product **229** was obtained, but since alkyl stannane impurities could not be completely removed, the exact yield could not be determined.

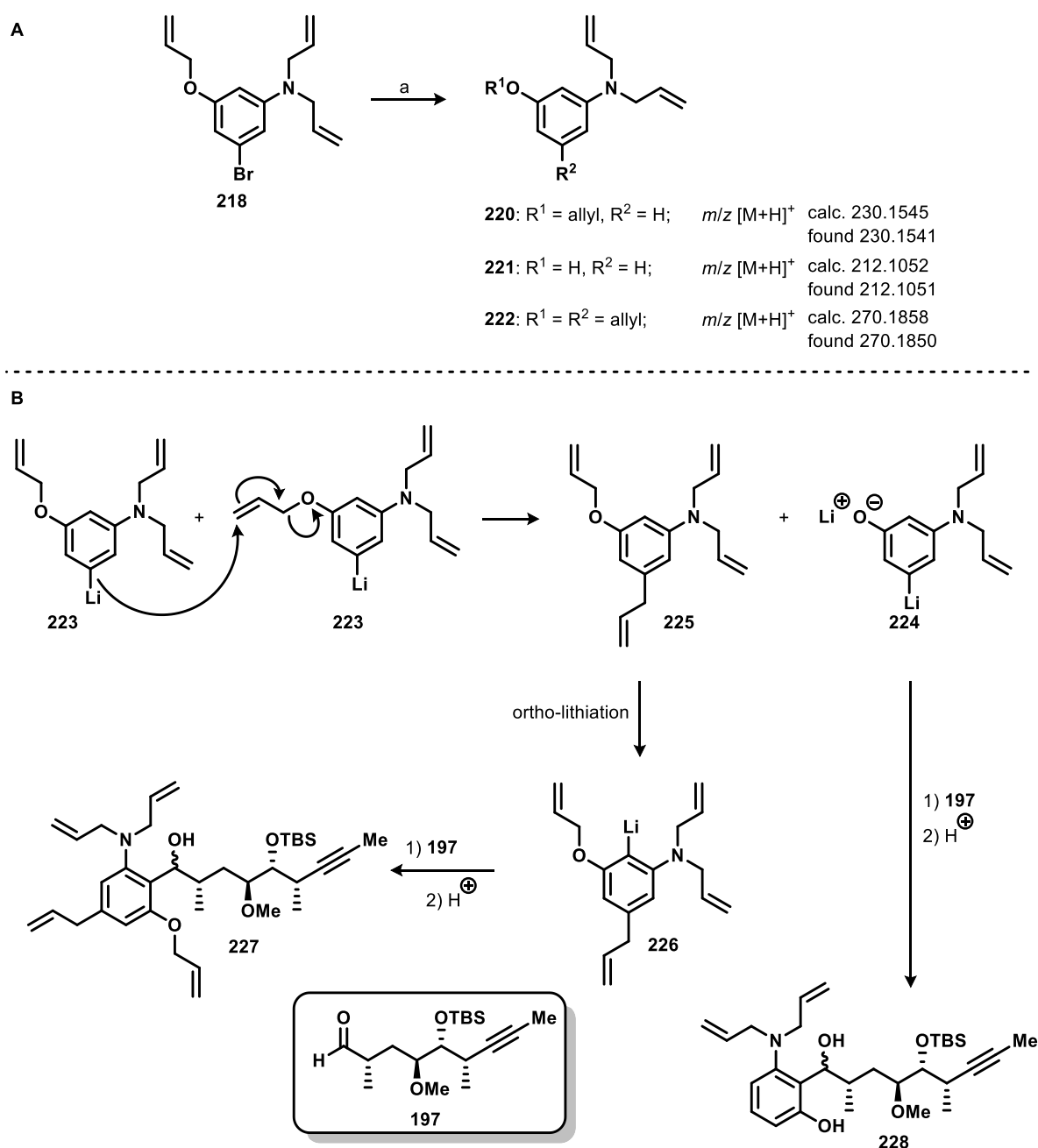

**Scheme 66:** A) Observed products after lithiation by HRMS analysis. Conditions: a) *t*-BuLi, Et<sub>2</sub>O, -78 °C, 15 min, yield n.d.. B) Proposed mechanism for the formation of the two observed by-products **227** and **228**.

Nevertheless, it was shown, that the introduction of the arene by 1,2-addition and subsequent deoxygenation was in principle a successful strategy. Therefore, the protection group of the phenol was changed and the sequence was repeated. Since it was already known, that a TBS ether was not stable under the allylation conditions, other silyl based protection groups were not further taken into account. Instead, the phenol should be protected as its methoxymethyl (MOM) ether. In contrast to the previous preparations of the bromo arenes, the synthesis of arene **230** began with the MOM protection of the phenol of 3-bromo-5-nitrophenol, before the nitro group was reduced to give arene **231**. MOM ethers are known to be stable under different nitro group reducing conditions. Catalytic hydrogenation with Pd/C would not be suitable for this substrate, because the loss of the bromine atom was reported for a similar substrate.<sup>[169]</sup>

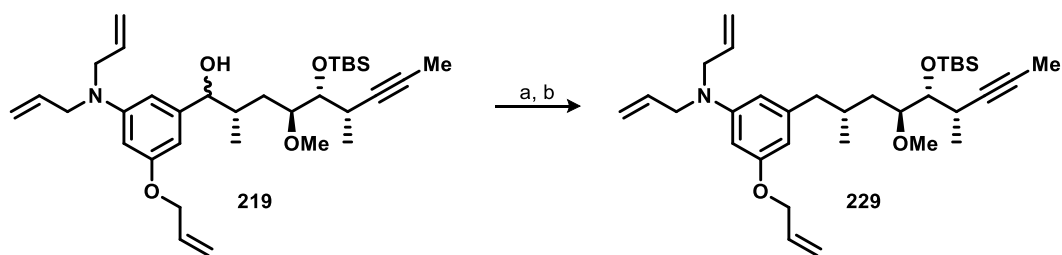

**Scheme 67:** Barton-McCombie deoxygenation of benzylic alcohol **219**. Conditions: a) NaHMDS, THF, rt, 30 min, then CS<sub>2</sub>, 0 °C, 15 min, then MeI, rt, 1 h, 32%, 40% brsm; b) Bu<sub>3</sub>SnH, Et<sub>3</sub>B, air, PhMe, rt, 1 h, yield n.d..

Consequently, SnCl<sub>2</sub>·2H<sub>2</sub>O was used and afforded aniline **232**, which was treated with allyl bromide as mentioned before and gave arene **230** in 50% yield over three steps without the need for purifications of the intermediates (Scheme 68). As an alternative and to avoid toxic MOMCl, the benzyl ether **233** was prepared by the same strategy, but could not be obtained in sufficient purity. Therefore, work was continued exclusively with MOM ether **230**.

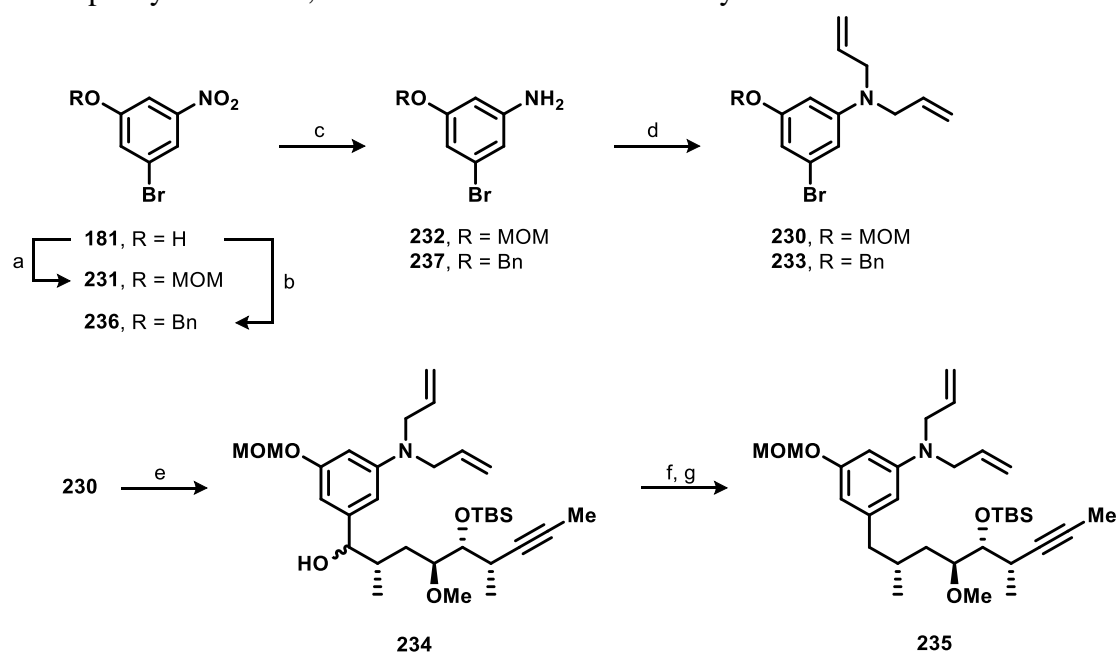

**Scheme 68:** Preparation of aryl bromides **230** and **233**. Subsequent 1,2-addition of aryl bromide **230** to aldehyde **197**. Conditions: a) NaH, DMF, 0 °C, 30 min, then MOMCl, 0 °C to rt, 1.5 h; b) K<sub>2</sub>CO<sub>3</sub>, BnBr, acetone, 70 °C, 6 h, 85%; c) SnCl<sub>2</sub>·2H<sub>2</sub>O, THF/EtOH (1:1), rt, 4 h; d) K<sub>2</sub>CO<sub>3</sub>, allyl bromide, DMF, 70 °C, 6 h, 50% o3s for **230**, 77% o2s for **233**; e) *t*-BuLi, Et<sub>2</sub>O, -78 °C, 1 h, then **197**, -78 °C, 4 h, 58%, *d.r.* = 1:1.4; f) NaHMDS, THF, rt, 15 min, then CS<sub>2</sub>, 0 °C, 20 min, then MeI, rt, 20 min, 74%; g) Bu<sub>3</sub>SnH, Et<sub>3</sub>B, air, PhMe, rt, 3 h, 52%.

The 1,2-addition was repeated under the same conditions as before, yielding benzylic alcohol **234** in 58% yield with no evidence of allyl migration. The ensuing formation of the methyl xanthate and the deoxygenation occurred uneventful in acceptable yields furnishing **235**

Again, since alkyl stannane impurities could not be completely removed, a different method for deoxygenation employing water as the hydrogen atom source was used.<sup>[170]</sup> Mechanistically, Et<sub>3</sub>B serves again the as radical initiator by auto oxidation with molecular oxygen liberating an ethyl radical (Scheme 69). This reacts with xanthate **238** providing intermediate **239**, which decomposes to *S*-ethyl-*S*-methyl dithiocarbonate (**240**) and the substrate-derived alkyl radical **241**, which is then reduced by the Et<sub>3</sub>B·H<sub>2</sub>O complex (**242**) to give deoxygenated product **243**, diethyl borinic acid (**244**) and an ethyl radical which can propagate the radical chain.

Unfortunately, this method resulted in the partial decomposition of the product. Presumably, the required excess of  $\text{Et}_3\text{B}$  (3.0 eq.) led to undesirable side reactions. Therefore, the deoxygenation protocol employing  $\text{Bu}_3\text{SnH}$  remained the method of choice.

Since the MOM protected phenol proved to be very suitable for the 1,2-addition-deoxygenation approach, a change in the protecting group of the homopropargylic alcohol seemed appropriate.

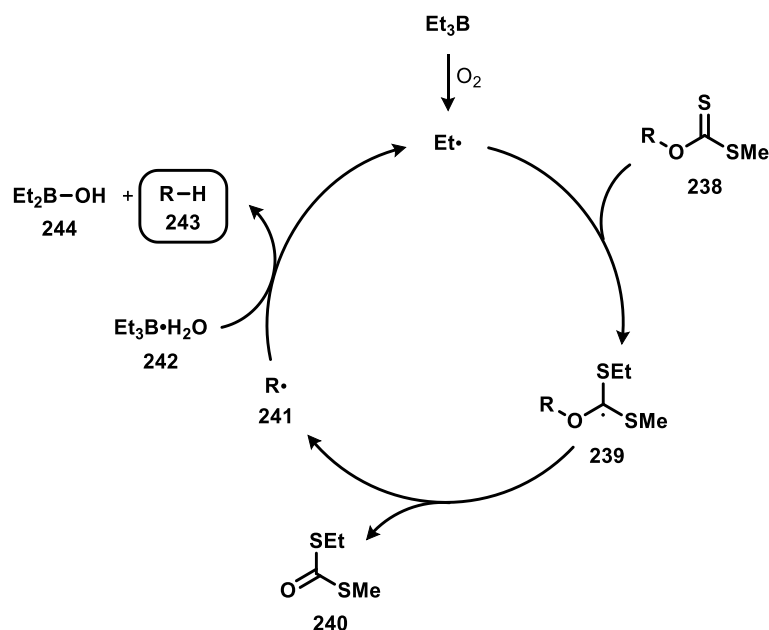

**Scheme 69:** Postulated mechanism for the deoxygenation of xanthates employing water as hydrogen atom source.<sup>[170]</sup>

Using a MOM ether as well for this alcohol would allow the simultaneous deprotection of these two alcohols towards the end of the synthesis. The MOM protection of homopropargylic alcohol **122** using MOMCl and NaH, however, was unsuccessful. The *in situ* formation of the more reactive MOMI by using MOMCl, TBAI, DIPEA and DMAP in contrast, resulted in a clean reaction furnishing protected alcohol **245** in 80% yield (Scheme 70).

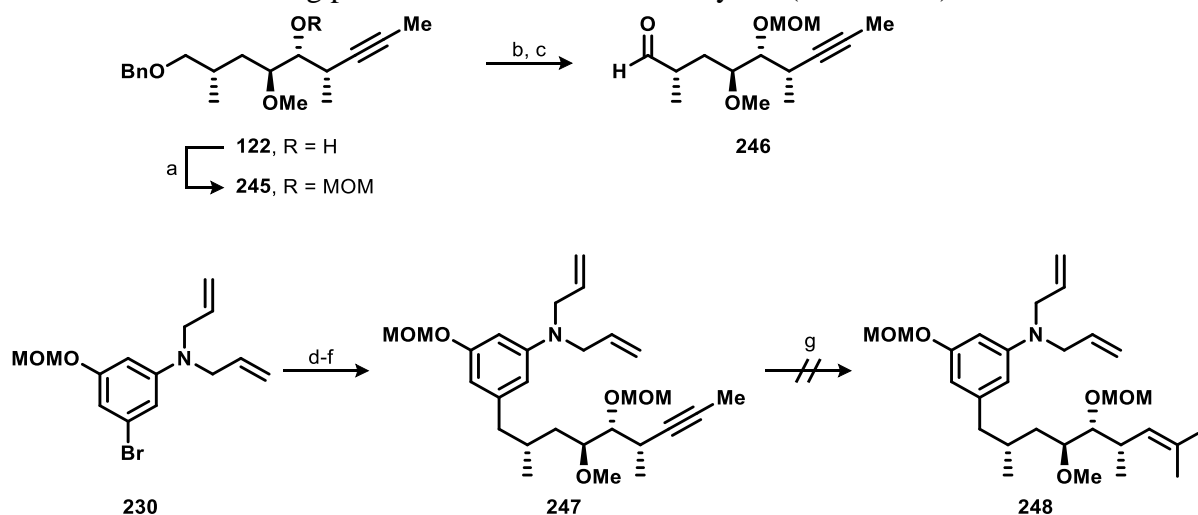

**Scheme 70:** Preparation of alkyne **247** and attempted preparation of vinyl iodide **248**. Conditions: a) MOMCl, DIPEA, TBAI, DMAP,  $\text{CH}_2\text{Cl}_2$ ,  $0\text{ }^\circ\text{C}$  to  $40\text{ }^\circ\text{C}$ , 6 h, 80%; b) LiDBB, THF,  $-78\text{ }^\circ\text{C}$ , 30 min, 81%; c) DMP,  $\text{NaHCO}_3$ ,  $\text{CH}_2\text{Cl}_2$ ,  $0\text{ }^\circ\text{C}$  to rt, 1.5 h, 98%; d) *t*-BuLi,  $\text{Et}_2\text{O}$ ,  $-78\text{ }^\circ\text{C}$ , 45 min, then **246**,  $-78\text{ }^\circ\text{C}$ , 2 h, 55%, *d.r.* = 1:1.2; e) NaHMDS, THF, rt, 15 min, then  $\text{CS}_2$ ,  $0\text{ }^\circ\text{C}$ , 20 min, then MeI, rt, 20 min, 90%; f)  $\text{Bu}_3\text{SnH}$ ,  $\text{Et}_3\text{B}$ , air, PhMe, rt, 1 h, 82%; g)  $\text{Cp}_2\text{ZrHCl}$ , THF,  $50\text{ }^\circ\text{C}$ , 1 h, then  $\text{I}_2$ ,  $-78\text{ }^\circ\text{C}$ , 1 h.

Debenzylation and oxidation giving rise to aldehyde **246** were carried out as mentioned above and the 1,2-addition proceeded without problems. The subsequent methyl xanthate formation occurred in an increased yield of 90%. Even more encouragingly, after the ensuing deoxygenation, the increased polarity of the molecule due to the introduction of the second MOM group, allowed for the separation of alkyl stannane residues, giving rise to **247** in 82% and high purity.

In order to perform the envisaged NHK coupling with aldehyde **54**, hydrozirconation followed by iodination were the last two steps to complete the synthesis of western fragment **248**. Unfortunately, under the conditions established earlier for hydrozirconation, the allyl groups were not stable and were partially reduced to the alkane or to the alkyl iodide resulting in a complex mixture of undesired products. To this point, no suitable conditions for the hydrozirconation were found.

### 3.3.6 Reformatsky Reaction

Although the introduction of the aromatic moiety by 1,2-addition followed by deoxygenation was successful, the original idea of incorporating the aromatic moiety first followed by fragment coupling no longer seemed reasonable. Nevertheless, the established conditions for 1,2-addition and deoxygenation should be equally well suited for the introduction of the arene after fragment coupling has occurred.

At this time, the synthesis lacked a suitable method for the stereoselective generation of the allylic alcohol at C-7. Reduction of the ketone obtained after oxidation of the diastereomeric alcohol derived from the NHK as shown in chapter 3.3.2 appeared as the most successful approach. Yet, the NHK reaction suffered from low yields and substantial material losses due to alkene formation. Therefore, an easier access to enone **249** was sought (Scheme 71).

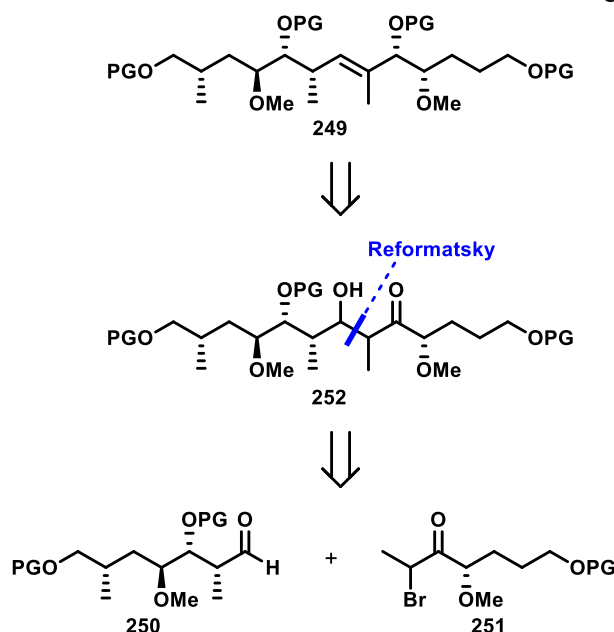

**Scheme 71:** Retrosynthetic analysis for the Reformatsky reaction.

The  $\text{SmI}_2$ -mediated Reformatsky reaction is a powerful method for the generation of  $\beta$ -hydroxy ketones from aldehydes and  $\alpha$ -halo carbonyls. Subsequent dehydration would provide an  $\alpha,\beta$ -unsaturated ketone. Inspired by work of Bach *et al.* in the context of a similar synthetic challenge<sup>[171]</sup>, aldehyde **250** and  $\alpha$ -bromoketone **251** would be suitable substrates for

the Reformatsky reaction. The aldehyde was prepared in a four step sequence starting from known aldehyde **131** (Scheme 72). Roush crotylation under the optimized conditions as described in chapter 3.2.1.2 furnished homoallylic alcohol **252** in good yield and excellent diastereoselectivity (*d.r.* = 17:1). After protection of the alcohol, dihydroxylation with NMO in presence of catalytic amounts of OsO<sub>4</sub> provided diastereomeric diol **253** which was cleaved with NaIO<sub>4</sub> giving rise to aldehyde **254** in good yields.

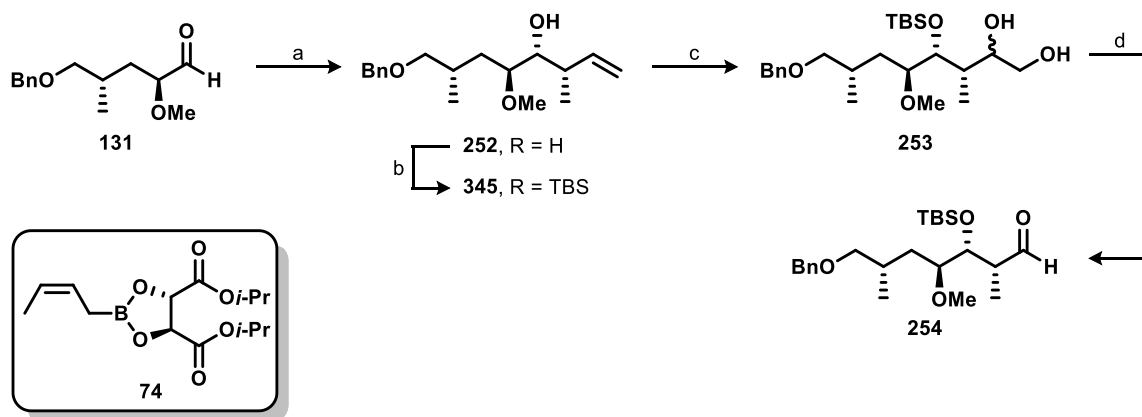

**Scheme 72:** Preparation of aldehyde **254**. Conditions: a) **74**, molecular sieves 4 Å, PhMe, -78 °C, 18 h, 68%, *d.r.* = 17:1; b) TBSOTf, 2,6-lutidine, CH<sub>2</sub>Cl<sub>2</sub>, 0 °C to rt, 45 min, 74%; c) NMO, OsO<sub>4</sub>, CH<sub>2</sub>Cl<sub>2</sub>, rt, 18 h, 79%; d) NaIO<sub>4</sub>, acetone/H<sub>2</sub>O (4:1), rt, 3 h, 61%, 73% brsm.

The synthesis of the  $\alpha$ -bromoketone commenced with a Grignard addition of EtMgBr to aldehyde **54**. Oxidation of the resulting alcohol furnished ethyl ketone **255**.  $\alpha$ -Bromination using LiHMDS and NBS was unsuccessful. Using phenyltrimethyl ammonium tribromide (PTAB) instead introduced the bromide, but led to cleavage of the TBS ether. Therefore, alcohol **50** was equipped with the more stable TBDPS ether and the aforementioned synthesis was repeated to give ketone **256**. Under the bromination conditions, the TBDPS group remained intact as observed by crude NMR. The purified product could not be used immediately and had to be stored at -25 °C for one night. Unfortunately, the material decomposed during storage. These experiments were carried out towards the very end of this work. And since aldehyde **254**, which was expected to be prone to  $\alpha$ -racemization, was already prepared, there was not enough time to repeat the whole synthesis of the eastern fragment. With the minimal amount of material of ketone **256** that was left,  $\alpha$ -bromination was repeated and the crude  $\alpha$ -bromoketone **257** was directly subjected to the SmI<sub>2</sub>-mediated Reformatsky reaction with aldehyde **254**. The quality of SmI<sub>2</sub> is known to be critical to the success of the reaction and was therefore freshly prepared following an optimized protocol utilizing inactivated samarium metal and iodine as oxidant.<sup>[172,173]</sup> Gratifyingly, expected  $\beta$ -hydroxy ketone **258** was observed by mass analysis.

Due to the time constraints mentioned above, subsequent dehydration using Martin's sulfurane was performed with the crude material giving rise to  $\alpha,\beta$ -unsaturated ketone **259**, which was also identified by mass analysis (Scheme 73). Although the amount of material was insufficient for NMR analysis and the Reformatsky reaction could not be repeated on a larger scale within the scope of this thesis, it was demonstrated that this is in principle a suitable method for the synthesis of the  $\alpha,\beta$ -unsaturated ketone. Considering that the Roush crotylation gave higher yields and a significantly better diastereoselectivity compared to the

Marshall propargylation, and that the subsequent transformations towards aldehyde **254** were very smooth, further studies following this approach seem very promising.

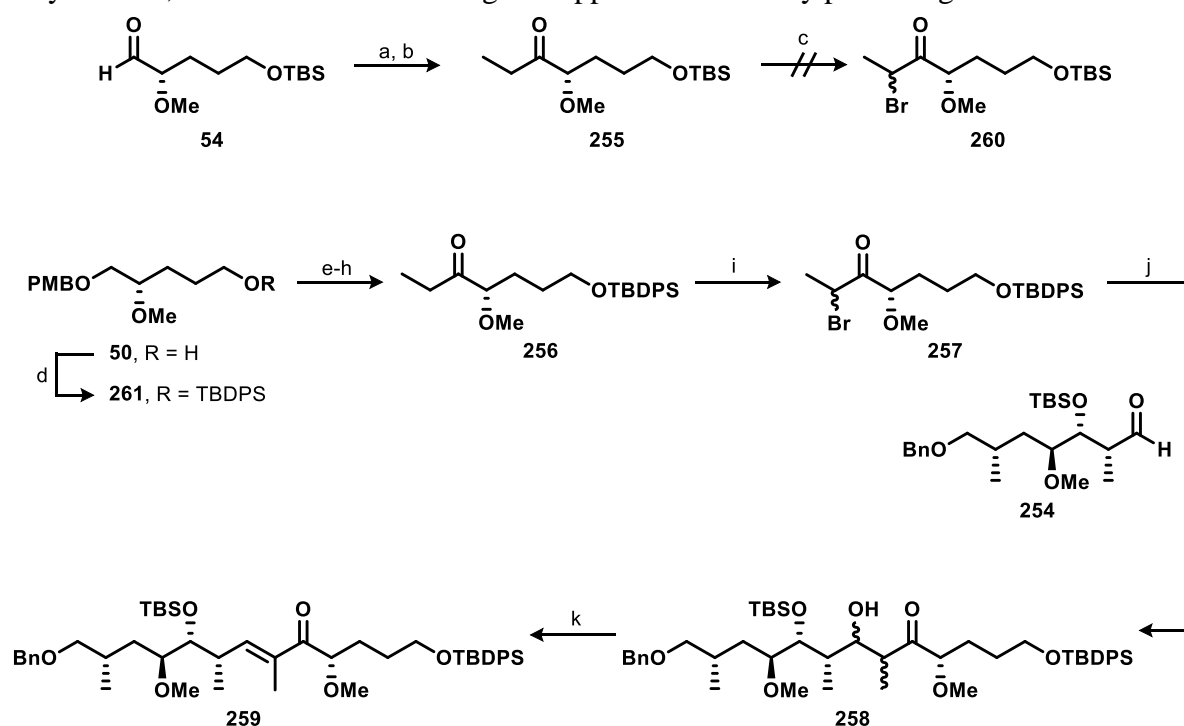

**Scheme 73:** Preparation of  $\alpha$ -bromoketone **257** and subsequent  $\text{SmI}_2$ -mediated Reformatsky reaction followed by dehydration giving rise to  $\alpha,\beta$ -unsaturated ketone **259**. Due to the instability of the  $\alpha$ -bromoketone and therefore the minimal amounts of material available for the bromination, Reformatsky reaction and dehydration step (see text), the yields could not be determined. Conditions: a)  $\text{EtMgBr}$ , THF,  $-78^\circ\text{C}$ , 30 min, then  $0^\circ\text{C}$ , 1 h, 81%; b) DMP,  $\text{NaHCO}_3$ ,  $\text{CH}_2\text{Cl}_2$ ,  $0^\circ\text{C}$  to rt, 1.5 h, 84%; c) see i); d) TBDSPI, DMAP, imidazole,  $\text{CH}_2\text{Cl}_2$ ,  $35^\circ\text{C}$ , 3 h, 95%; e) DDQ,  $\text{CH}_2\text{Cl}_2/\text{pH7}$  phosphate buffer (9:1),  $0^\circ\text{C}$  to rt, 1.5 h, 76%; f) DMP,  $\text{NaHCO}_3$ ,  $\text{CH}_2\text{Cl}_2$ ,  $0^\circ\text{C}$  to rt, 1.5 h, 95%; g)  $\text{EtMgBr}$ , THF,  $-78^\circ\text{C}$ , 30 min,  $0^\circ\text{C}$ , 1 h; h) DMP,  $\text{NaHCO}_3$ ,  $\text{CH}_2\text{Cl}_2$ ,  $0^\circ\text{C}$  to rt, 1.5 h, 72% o2s; i) PTAB, THF,  $0^\circ\text{C}$  to rt, 2.5 h, yield n.d.; j)  $\text{SmI}_2$ , THF,  $-78^\circ\text{C}$ , yield n.d.; k) Martin's sulfuran,  $\text{CH}_2\text{Cl}_2$ ,  $0^\circ\text{C}$ , 1 h, yield n.d.

### 3.4 Test Substrates for GdmF

While the synthetic work on *seco*-progeldanamycin was still ongoing, GdmF was heterologously expressed and isolated by Carsten Zeilinger and Anja Heutling. Later, the expression, isolation and purification was improved by Wiebke Ewert from the Preller group.<sup>[60]</sup> To test the protein for activity and to establish an enzymatic assay using GdmF for amide synthesis, substrate analogs should be synthesized. These analogs could also be used in co-crystallization experiments with GdmF, providing insights into the binding of substructures that are part of the natural *seco*-progeldanamycin in the active site of GdmF. This would shed light on the hitherto unknown mechanism of activation of *seco*-substrates for amide syntheses. In most NATs the substrate is activated by attachment to acetyl coenzyme A as the acetyl carrying co-substrate. However, previous results from our group suggest that the *seco*-substrates are bound to shorter co-substrates before being transported to the binding site.<sup>[32,174]</sup> Therefore, truncated test substrates resembling the *ansa*-chain bearing a SNAC (**262**) or pantetheine (**263**) residue were chosen as candidates. In addition, 3-amino-5-methylphenol (**264**), which was readily available from 5-methylresorcinol (**265**), and commercially available 3-aminophenol (**266**) were selected as mimics for the aromatic moiety in *seco*-progeldanamycin (Scheme 74).

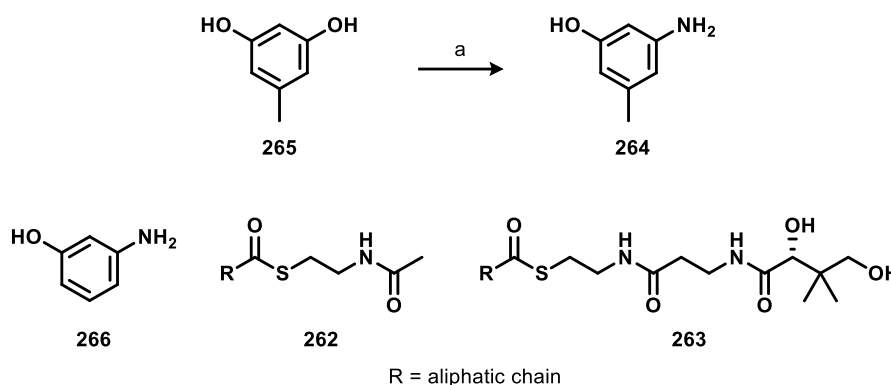

**Scheme 74:** General overview of test substrates for GdmF. Conditions: a)  $\text{NH}_4\text{Cl}$ ,  $\text{NH}_3$  (28%, aq.), 180 °C, autoclave, 18 h, 52%.

### 3.4.1 SNAC and Pantetheine Thioesters

The SNAC thioesters (**267-269**) were prepared by coupling of *N*-acetylcysteamine (**270**) with commercially available carboxylic acids ((*E*)-but-2-enoic acid, (*E*)-2-methylbut-2-enoic acid, (*E*)-2-methylpent-2-enoic acid) using standard conditions known from peptide coupling chemistry in good yields (Scheme 75). The selection of acids was made to compare a possible influence of the trisubstituted double bond as well as the length of the aliphatic chain on the activity of GdmF. Attempts to prepare acetyl SNAC using acetic acid failed.

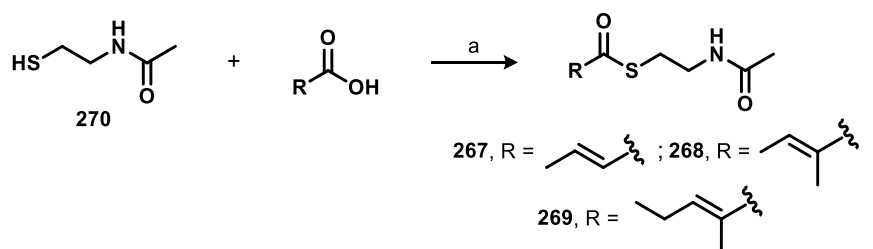

**Scheme 75:** Preparation of SNAC thioesters **267-269**. Conditions: a) EDC·HCl, DMAP,  $\text{CH}_2\text{Cl}_2$ , 0 °C to rt, 3 h, 76% for **267**, 73% for **268**, 63% for **269**.

The pantetheine thioesters were prepared by the same strategy (Scheme 76). Commencing with D-pantothenic acid hemi calcium salt (**271**) D-pantothenic dimethyl ketal (**272**) was prepared by acid catalyzed acetalization with acetone according to a procedure published by Townsend *et al.* in acceptable yield.<sup>[175]</sup> An alternative protocol by Zhang *et al.*<sup>[176]</sup> using dimethoxypropane with CSA and conc.  $\text{H}_2\text{SO}_4$  gave significantly worse results. Peptide coupling mediated by CDI of the obtained pantothenic acid dimethyl ketal with cysteamine hydrochloride furnished pantetheine dimethyl ketal **273**. The subsequent peptide coupling with the respective acids (acetic acid, (*E*)-pent-2-enoic acid, (*E*)-2-methylbut-2-enoic acid) under the above conditions gave rise to acyl pantetheine dimethyl ketals **274-276**. Deprotection of the acetonide with TFA in  $\text{CH}_2\text{Cl}_2$  (10% V/V) at room temperature was successful but furnished the pantetheine derivatives in only vanishingly low yields (<5%). Instead, the use of  $\text{InCl}_3$  and water in MeCN provided a very mild and effective method for deprotection furnishing acyl pantetheines **277-279** in 50-56% yield.<sup>[177]</sup>



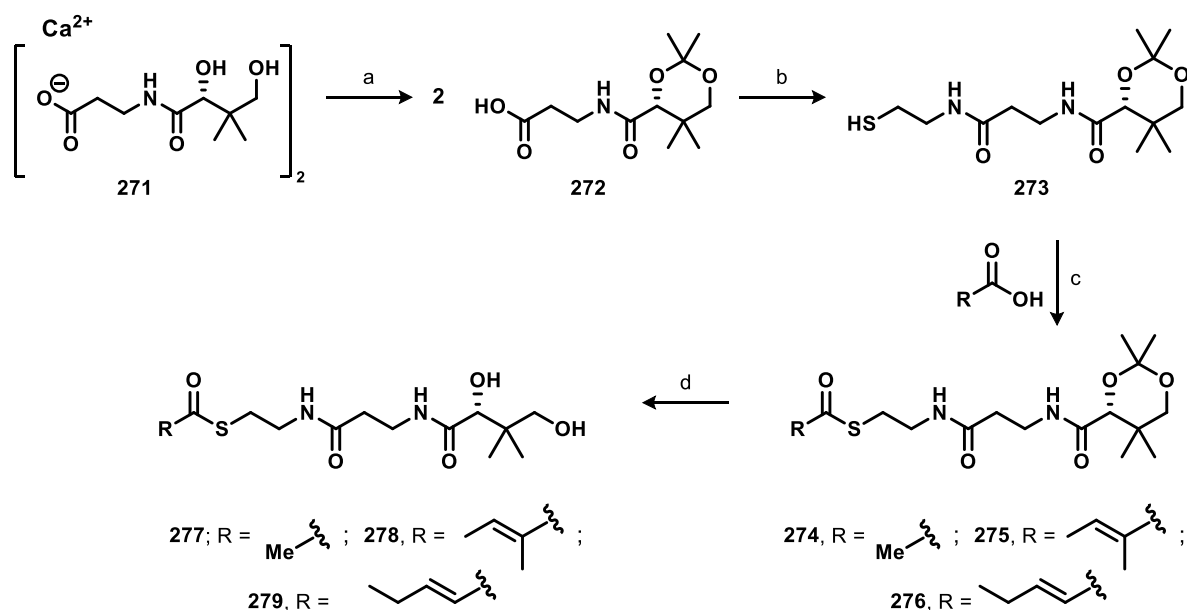

**Scheme 76:** Preparation of pantetheine thioesters **277-279**. Conditions: a) *p*-TsOH·1H<sub>2</sub>O, molecular sieves (3 Å), acetone, rt, 12 h, 71%; b) CDI, cysteamine hydrochloride, THF, rt, 12 h, 87%; c) EDC-HCl, DMAP, CH<sub>2</sub>Cl<sub>2</sub>, 0 °C to rt, 2 h, 78% for **274**, 81% for **275**, 64% for **276**; d) InCl<sub>3</sub>, H<sub>2</sub>O (4.0 eq.), MeCN, rt, 16 h, 50% for **277**, 52% for **278**, 56% for **279**.

### 3.4.2 Enzymatic Assays

With the test substrates at hand, suitable conditions were sought for the enzymatic assay using GdmF for amide synthesis. Therefore, the above arenes (**264** and **266**) and thioesters (**267-269** and **277-279**) were incubated with GdmF (Scheme 77).

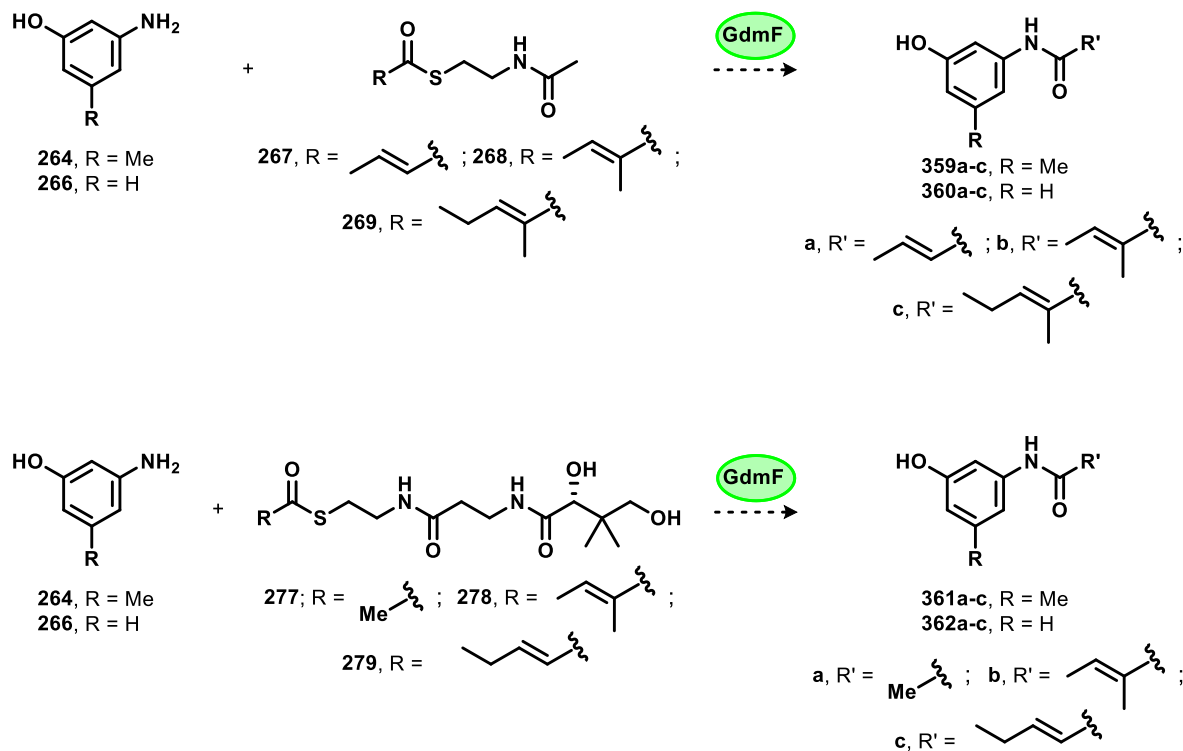

**Scheme 77:** Envisaged enzymatic assays with isolated GdmF using arenes **264** and **266** and pantetheine thioesters **277-279** and SNAC thioesters **267-269**.

The assay was performed as triplicate in 500  $\mu$ L aliquots in TRIS·HCl (20 mM, pH 7.4) buffer (= "buffer A") (Table 1). The substrates were used as stock solution in DMSO and had

a final concentration of 500  $\mu\text{M}$  per aliquot. The enzyme had a final concentration of 200 nM per aliquot. After preincubation of the protein with the aniline for 5 min at 30 °C, the respective thioester was added. As negative control the substrates were incubated under the same conditions, but in the absence of GdmF. The difference in volume was compensated with buffer. The aliquots were shaken at low speed (200 rpm) at 37 °C for 30 min, 1 h, 3 h, 6 h and 24 h. The assay was extracted with 250  $\mu\text{L}$  EtOAc twice and the solvent of the combined organic phases was removed in a vacuum concentrator. The residue was dissolved in 500  $\mu\text{L}$  MeOH and analyzed by HRMS. In none of the aliquots the expected amide (**359a-c**, **360a-c**, **361a-c**, **362a-c** see Scheme 77) could be observed. While the arenes remained unaltered, both the thioester substrates (**267-269** and **277-279**) and the respective thiols resulting from hydrolysis of the thioesters were detected. After 24 h only the thiol was observed. Interestingly, analysis of the negative control revealed thiol formation after 3 h as well, increasing over time. It was hypothesized that 37 °C might be too warm, resulting in both degradation of the protein and thus prevention of amide formation and decomposition of the thioesters. Therefore, the assay was repeated at room temperature. Furthermore, EDTA (1 mM) and sucrose (3%) were added to the TRIS·HCl (20 mM, pH 7.4) buffer (= “buffer B”) as stabilizing agents. Additionally, acetyl-CoA and *isobutyryl*-CoA were included in the set of thioesters to be tested. Under these conditions, the thioesters were much more stable and were only partially hydrolyzed after 24 hours, as shown by the negative control without GdmF. However, with GdmF, again no amide formation but thiol formation was observed. After only 1 hour, no more thioester substrate was detected. By this time, Ewert was able to optimize the buffer conditions to obtain maximum protein stability by using a thermal shift assay. It could be shown that the pH range is very limited to pH 7.5. Sugar, glycerol, DTT or DMSO had a positive effect on stabilization. In contrast, the addition of salts, EDTA or urea had no significant positive effect. On the contrary, when NaCl was added, even a slight deviation from pH 7.5 resulted in dramatic destabilization effects.<sup>[60]</sup> Although, DMSO per se does not have a stabilizing effect, its non-existent destabilizing effect is of great importance since the substrates are used as stock solutions in DMSO. Thus, complications due to the use of DMSO can be excluded. Nevertheless, care was taken to ensure that the amount of DMSO in the aliquot did not exceed 5%. Considering these findings, the assay was repeated using 20 mM TRIS-HCl buffer, pH 7.5 and 1 mM DTT. Yet, amide formation was still not observed, with the hydrolysis being the predominant reaction. Since these experiments showed that hydrolysis was significantly faster when GdmF was present, it was assumed that the thioesters were hydrolyzed by GdmF. This assumption was undermined by co-crystallization experiments of GdmF with pantetheines **277-279** and SNACs **267-269** together with anilines **265** and **266** that were performed by Ewert.<sup>5</sup> The structures were resolved at resolutions ranging from 1.28 to 1.82 Å. In the substrate-loaded structures, the thioester groups could not be identified, but electron densities for the hydrolyzed SNACs or pantetheines were found. The sulfhydryl groups appeared in close proximity to the reactive cysteine Cys73. These findings suggest that GdmF is capable of directly binding SNAC and pantetheine thioesters and thus catalyzing the first step of macrolactamization. This means that the thioester can be cleaved by GdmF in the absence of the anilines. The rather unusual widened active site cleft

---

<sup>5</sup> Details for the crystallization experiments can be found in the doctoral thesis of Wiebke Ewert.<sup>[60]</sup>

in GdmF compared to other NAT structures, allows easy access of water molecules into the active site, causing the undesired hydrolysis of the thioesters. In the presence of a long ketide chain, such as in native *seco*-progeldanamycin (**280**), the unstructured interdomain region could transform into a helical structure and protect the active site from surrounding water.<sup>[60,178]</sup> Based on these results it did not seem reasonable to perform further experiments on the enzymatic turnover of thioesters to amides at this time.

**Table 1:** Results of the enzymatic assays with isolated GdmF using arenes **264** and **266** and pantetheine thioesters **277-279** and SNAC thioesters **267-269**. The products were analyzed by HRMS.

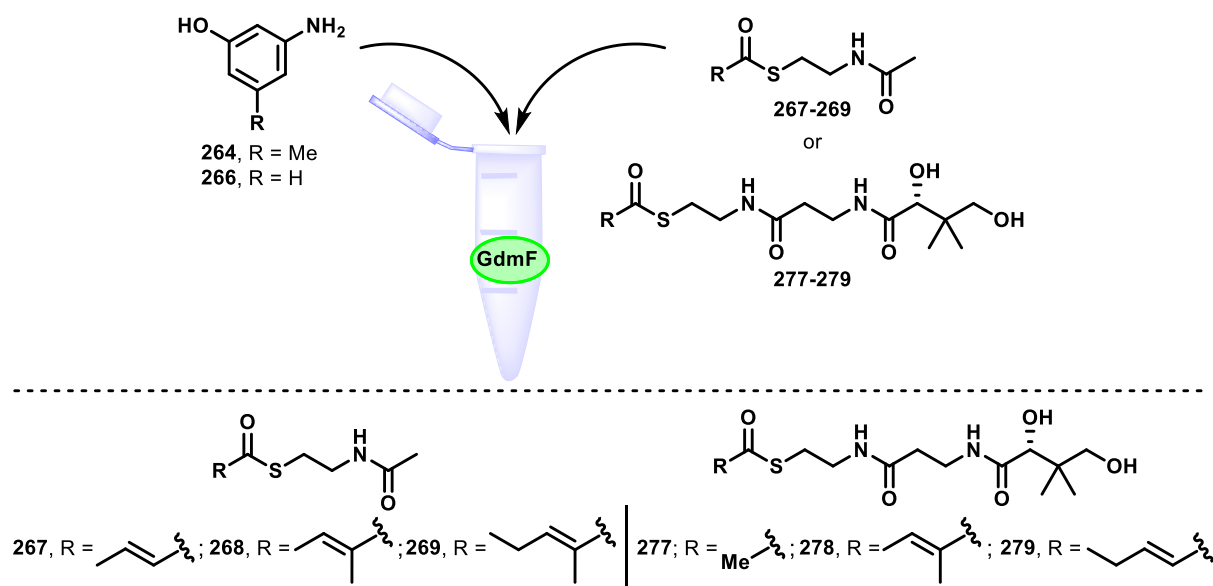

| conditions          | buffer <sup>a</sup> | substrate |                        | result <sup>b, c</sup> (observed products) |                 |     |                 |      |
|---------------------|---------------------|-----------|------------------------|--|-----------------|-----|-----------------|------|
|                     |                     | arene     | thioester              | 30 min                                     | 1 h             | 3 h | 6 h             | 24 h |
| without GdmF, 37 °C | A                   | 264, 266  | 267-269                | 267-269                                    | 267-269 + thiol |     |                 |      |
|                     |                     |           | 277-279                | 277-279                                    | 277-279 + thiol |     |                 |      |
| GdmF, 37 °C         | A                   | 264, 266  | 267-269                | 267-269 + thiol                            |                 |     | thiol           |      |
|                     |                     |           | 277-279                | 277-279 + thiol                            |                 |     | thiol           |      |
| without GdmF, rt    | B                   | 264, 266  | 267-269                | 267-269                                    |                 |     | 267-269 + thiol |      |
|                     |                     |           | 277-279                | 277-279                                    |                 |     | 277-279 + thiol |      |
|                     |                     |           | acetyl-CoA             | acetyl-CoA                                 |                 |     | CoASH           |      |
|                     |                     |           | <i>isobutyryl</i> -CoA | <i>isobutyryl</i> -CoA                     |                 |     | CoASH           |      |
| GdmF, rt            | B                   | 264, 266  | 267-269                | 267-269 + thiol                            |                 |     | thiol           |      |
|                     |                     |           | 277-279                | 277-279 + thiol                            |                 |     | thiol           |      |
|                     |                     |           | acetyl-CoA             | acetyl-CoA + CoASH                         |                 |     | CoASH           |      |
|                     |                     |           | <i>isobutyryl</i> -CoA | <i>isobutyryl</i> -CoA + CoASH             |                 |     | CoASH           |      |

<sup>a</sup> Buffer A: TRIS·HCl (20 mM, pH 7.4);

Buffer B: EDTA (1 mM), sucrose (3%), TRIS·HCl (20 mM, pH 7.4).

<sup>b</sup> In all reactions, the arene substrates (**264**, **266**) remained unaltered.

<sup>c</sup> “Thiol” refers to the respective hydrolyzed thioester of the SNAC (**267-269**) and pantetheine (**277-279**) substrates.

### 3.4.3 Non-Hydrolyzable Substrates

The hydrolysis of the thioesters prevented the generation of crystallographic structures that would reveal details about the orientation and coordination of the ketide residue in the active site. Non-hydrolyzable substrates, that is, substrates without the labile thioester function, would be very useful to clarify this issue.

First, amido analogs of the SNAC thioesters were envisioned, as these substrates were expected to be synthesized simply following the same peptide coupling strategy as above. Commencing with *N*-acetylenediamine (**281**), which was readily available by monoacetalization of ethylenediamine (**282**) with EtOAc, the ensuing peptide coupling was more problematic than expected. The same conditions as for the SNAC thioesters furnished both amido analogs **283** and **284** in only 17% (Scheme 78). Various changes in the coupling conditions using different coupling reagents such as HATU, HOBt, HOAt failed to improve the result, and since sufficient material was obtained for the co-crystallizations, no further efforts were made to improve the yield.

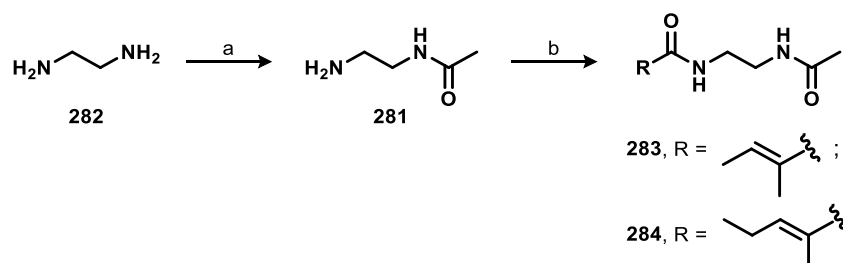

**Scheme 78:** Preparation of SNAC amido analogs. Conditions: a) EtOAc (1.0 eq.), MeOH, rt, 3 d, 77%; b) EDC·HCl, DMAP, CH<sub>2</sub>Cl<sub>2</sub>, 0 °C to rt, 3 h, 17% for **283**, 17% for **284**.

However, the co-crystallization experiments with these substrates did not reveal any electron density in the active site cleft that would indicate bound substrates.<sup>[60]</sup> Therefore, “carba” pantetheine analogs should be evaluated instead. Here, we sought a retrosynthetic strategy that would allow both the synthesis of truncated “carba” analogs (**285**, **286** and **287**) and the synthesis of the “carba” analog of *seco*-progeldanamycin (**288**) once its synthesis is complete (Scheme 79).

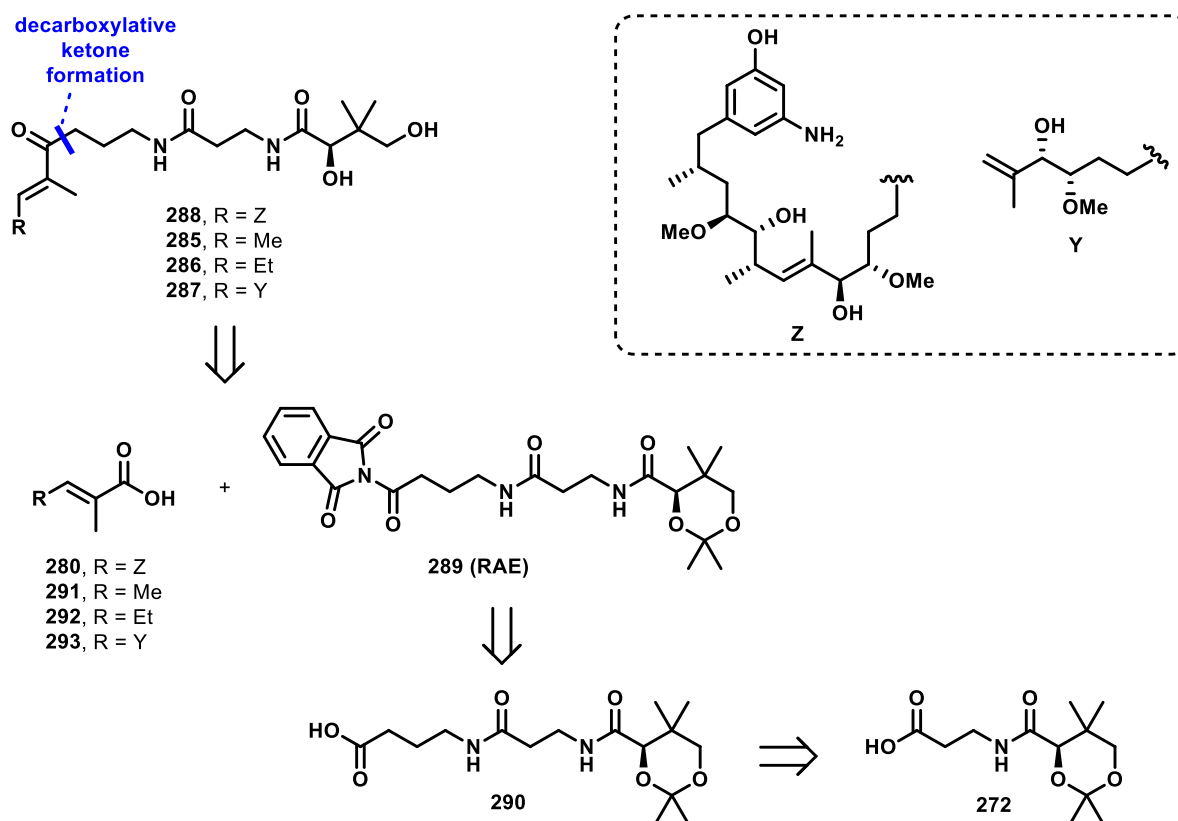

**Scheme 79:** Retrosynthetic approach towards a non-hydrolyzable "carba" pantetheine analog of *seco*-progeldanamycin (**288**) and truncated "carba" pantetheine analogs (**285**, **286** and **287**). RAE = redox-active ester.

These "carba" analogs should be synthesized by decarboxylative ketone formation of *seco*-acid **280** and redox-active ester (RAE, **289**) in a radical coupling approach. The trisubstituted double bond (C2-C3) in *seco*-progeldanamycin (**280**) can be introduced by a Wittig olefination, subsequent hydrolysis of the resulting ester would provide easy access to *seco*-acid **280**. Baran *et al.* reported a mild procedure for the synthesis of ketones from carboxylic acids and *N*-hydroxyphthalimids as the RAE.<sup>[179]</sup> They reported a broad scope, high functional group tolerance and an operationally simple reaction which made this methodology highly interesting. This method would furnish the desired "carba" analog (**280**) in just a single step without any further protection group or oxidation state manipulations from *seco*-acid **280**. Mechanistically, the RAE will provide the radical species (*vide infra*), therefore the  $\alpha,\beta$ -unsaturated acids would not be well suited as RAE. Possible delocalization of the radical through the double bond would lead to the formation of undesired by-products. Therefore, the RAE should be derived from peptide coupling of "carba" pantetheinic acid **290** with *N*-hydroxyphthalimide (NHPI). "Carba" pantetheinic acid **290** can be prepared from D-pantothenic dimethyl ketal (**272**). For the synthesis of truncated "carba" pantetheine analogs (**285**, **286** and **287**), commercially available carboxylic acids **291** and **292** as well as the more advanced acid **293** should be used.

In the protocol developed by Baran *et al.* the authors have used a benchtop and air stable nickel catalyst (Ni(BPhen)Cl<sub>2</sub>·2DMF, **294**) in concert with a set of reagents: (1) benzoic anhydride as activating agent for the carboxylic acid, (2) Zn as reducing agent and (3) MgCl<sub>2</sub> as Lewis acid. All components are added to a flask, followed by addition of solvent and the reaction is stirred at room temperature. From a mechanistic point of view (Figure 7), the authors proposed that the catalytic cycle starts with the initial oxidative addition by the

electrophilically activated carboxy group  $R^1$ -CO<sub>2</sub>H (as anhydride<sup>6</sup>, **A**) to the ligated Ni(0) species **I**.

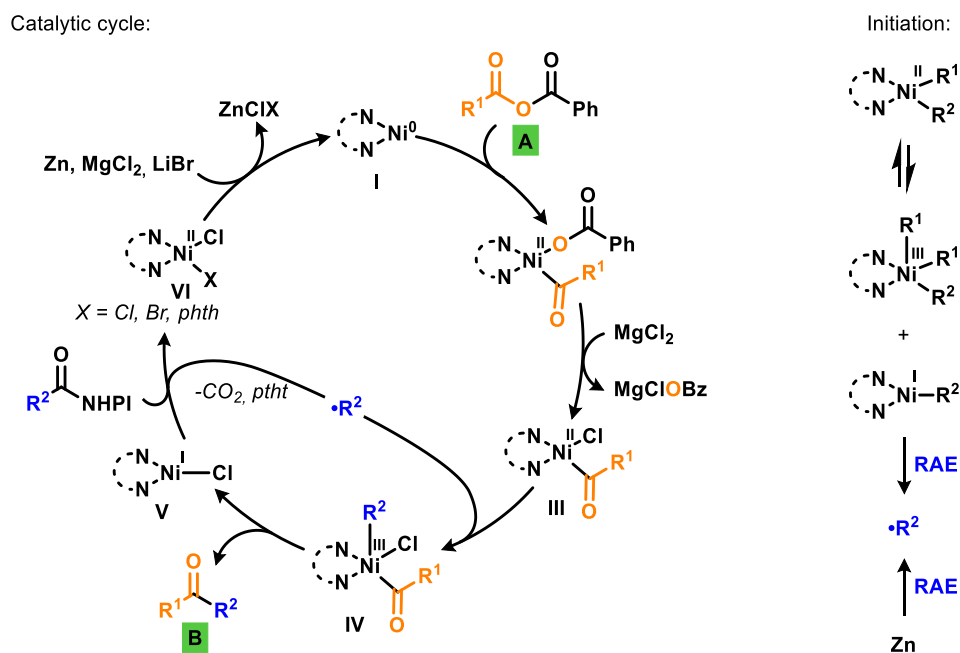

**Figure 7:** Postulated mechanism for the nickel-catalyzed decarboxylative synthesis of ketones from carboxylic acids. NHPI = *N*-hydroxyphthalimide; pht = phthalimide; RAE = redox-active ester.<sup>[179]</sup>

The critical oxidative addition occurs rapidly furnishing acyl-bound Ni(II)-carboxylate species **II**. Electronics dictate the selective insertion by **I** into the desired C-O bond, since the electron-deficient Ni(II) species **II** is better stabilized by the electron-rich alkyl component. Next,  $MgCl_2$  promotes the ligand exchange (carboxylate for chloride) that converts **II** to **III**. Complex **III** traps a radical ( $\bullet R^2$ ) derived from the RAE ( $R^2$ -CONHPI, **C**) to give Ni(III) intermediate **IV**. This step is supported by the persistent radical effect<sup>7</sup>.<sup>[180,181]</sup> Intermediate **IV** undergoes rapid reductive elimination furnishing the ketone product (**B**) and Ni(I) complex **V**. This complex **V** can then react with another RAE molecule to continue the cycle and generate Ni(II) species **VI**. Reduction by Zn affords complex **I** and completes the cycle. This final reduction step is further promoted by LiBr and  $MgCl_2$ . In addition, two other pathways for the RAE decomposition, that is, formation of the  $R^2$ -radical were rationalized. Disproportionation or a Zn mediated process would also give  $\bullet R^2$  (see “initiation”, Figure 7).

The required nickel catalyst was prepared by stirring  $NiCl_2 \cdot 6H_2O$  with bathophenanthroline (**295**) in DMF at 70 °C for 8 h (Scheme 80). The intensely green colored crystal catalyst could be handled and stored on the bench top without further precautions against moisture or air. A model system using 5-phenylvaleric acid (**296**) was chosen to test the catalyst. Preparation of RAE **297** under various coupling conditions using EDC·HCl as coupling reagent did not give satisfying results as the coupling remained incomplete. Changing to DIC provided complete consumption of the starting material, but the purification was quite tedious, and residues of

<sup>6</sup> The formation of the mixed anhydride is facilitated by  $MgCl_2$ .

<sup>7</sup> The persistent radical effect describes the selective formation of the cross-coupling product ( $R^1$ - $R^2$ ) between two radicals  $R^1$  and  $R^2$  when one species is persistent (long-lived) and the other is transient. When both radicals are formed at equal rates, the self-termination of the transient species causes the buildup in concentration of the persistent species. This directs the reaction to a single pathway, namely cross coupling.

DIC could not be completely removed. However, this was not problematic for the subsequent decarboxylative coupling. In fact, decarboxylative coupling using the NHPI-RAE prepared *in situ* proved to be equally efficient furnishing ketone **298** in 64% o2s after stirring at room temperature for 14 h (Scheme 80).

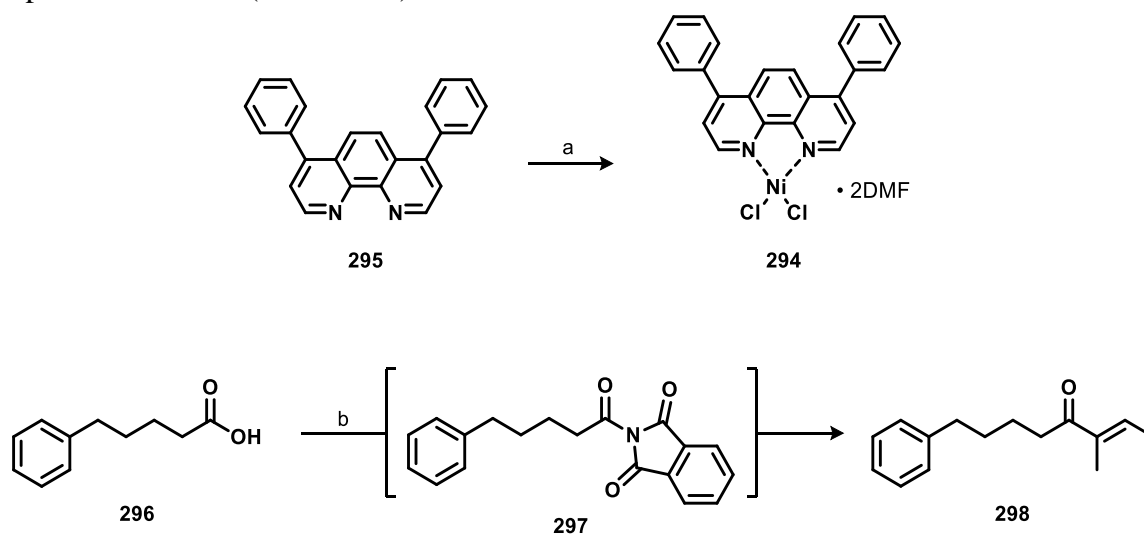

**Scheme 80:** Model system for the decarboxylative ketone formation using 5-phenylvaleric acid (**296**). Conditions: a)  $\text{NiCl}_2 \cdot 6\text{H}_2\text{O}$ , DMF, 70 °C, 8 h, 72%; b) NHPI, DIC,  $\text{CH}_2\text{Cl}_2$ , rt, 2 h, solvent change, then *(E)*-2-methylbut-2-enoic acid,  $\text{Ni}(\text{BPhen})\text{Cl}_2 \cdot 2\text{DMF}$  (**294**), Zn, benzoic anhydride,  $\text{MgCl}_2$ , LiBr, MeCN/THF (1:1.5), rt, 14 h, 64% o2s.

After verifying the efficiency of the method, it was applied to the actual system. The synthesis of RAE **289** commenced with benzylation of  $\gamma$ -aminobutyric acid (GABA, **299**) using benzyl alcohol and *p*-toluene sulfonic acid. Removal of the sulfonic acid by aqueous workup furnishing the free amine was associated with yield losses. Working with sulfonate **300** was much more convenient and the ensuing peptide coupling to D-pantothenic dimethyl ketal (**272**) with EDC·HCl, HOBT and DIPEA proceeded in excellent yield giving rise to **301**. Hydrogenation gave rise to the free carboxylic acid **290** which was subjected to *in situ* preparation of RAE **289** by peptide coupling with NHPI. The subsequent decarboxylative coupling employing *(E)*-2-methylbut-2-enoic acid (**291**) and *(E)*-2-methylpent-2-enoic acid (**292**) gave rise to ketones **302** and **303** in 37% o2s and 35% o2s, respectively. Subsequent cleavage of the acetonide under above conditions gave rise to “carba” pantetheine derivatives **285** and **286** (Scheme 81).

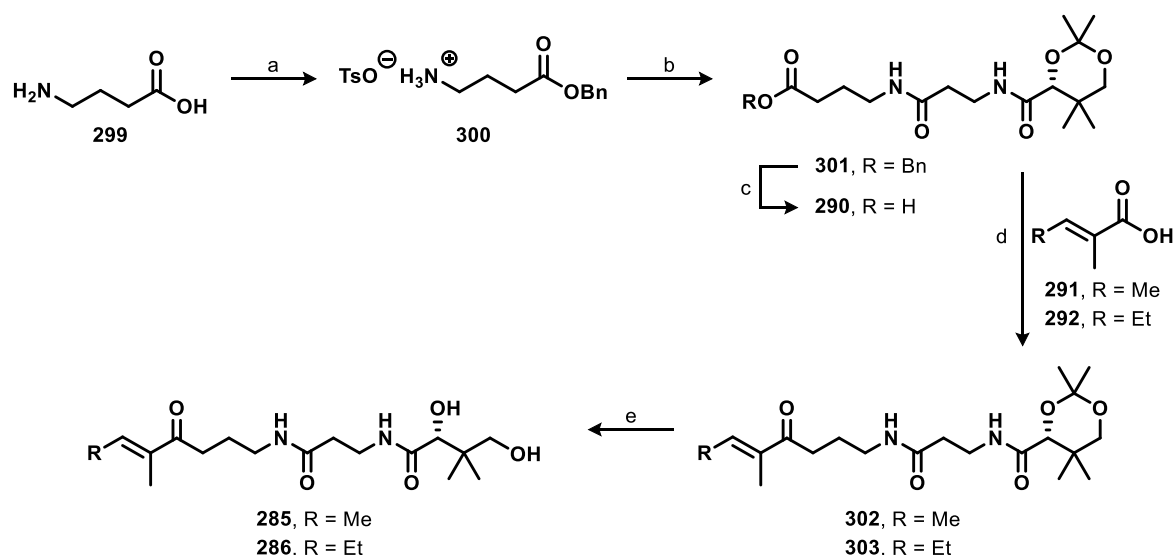

**Scheme 81:** Preparation of truncated “carba” analogs **285** and **286** by means of decarboxylative ketone formation. Conditions: a) BnOH, *p*TsOH·1H<sub>2</sub>O, PhMe, reflux, 5 h, 79%; b) **272**, HOBT·1H<sub>2</sub>O, EDC·HCl, DIPEA, CH<sub>2</sub>Cl<sub>2</sub>, rt, 24 h, 94%; c) Pd/C, H<sub>2</sub>, EtOAc/EtOH (3.5:1), rt, 1 h, 89%; d) NHPI, DIC, CH<sub>2</sub>Cl<sub>2</sub>, rt, 2 h, solvent change, then acid **291** or **292**, Ni(BPhen)Cl<sub>2</sub>·2DMF (**294**), Zn, benzoic anhydride, MgCl<sub>2</sub>, LiBr, MeCN/THF (1:1.5), rt, 14 h, 37% for **302**, 35% for **303**; e) InCl<sub>3</sub>, H<sub>2</sub>O, MeCN, rt, 16 h, 38% for **285**, 35% for **286**.

Pleased with the results of the decarboxylative coupling with the commercially available acids, the method should be applied to the preparation of “carba” analog **287** using acid **293**. This acid represents the eastern fragment of *seco*-progeldanamycin and is thus a very interesting substrate for co-crystallization experiments, as it can provide much more information about the orientation of the ketide chain in the active site compared to the much more truncated test substrates. The synthesis commenced with the preparation of bis-silyl ether **304**. Selective removal of the TBS ether was rather inefficient. Amongst different methods evaluated, using PPTS was the most successful, giving rise to primary alcohol **305** in acceptable 53% yield. Swern oxidation provided aldehyde **306** and Wittig olefination with ylene **307** gave  $\alpha,\beta$ -unsaturated ester **308**. Since the authors reported that the decarboxylative coupling tolerates free alcohols, the allylic silyl ether was already cleaved at this point with TBAF. Hydrolysis with aqueous LiOH solution at 40 °C overnight afforded the desired acid **293** in 20% over 6 steps (11s) starting from allylic alcohol **38**. As the selective desilylation was the bottleneck in this reaction sequence, protection of the allylic alcohol was revised and it was protected as acetate (**309**) instead. This change would also allow the deprotection and hydrolysis of the  $\alpha,\beta$ -unsaturated ester in just a single step. And indeed, repetition of the above sequence with **309** yielded acid **293** in 30% yield over 5 steps (11s) (Scheme 82).



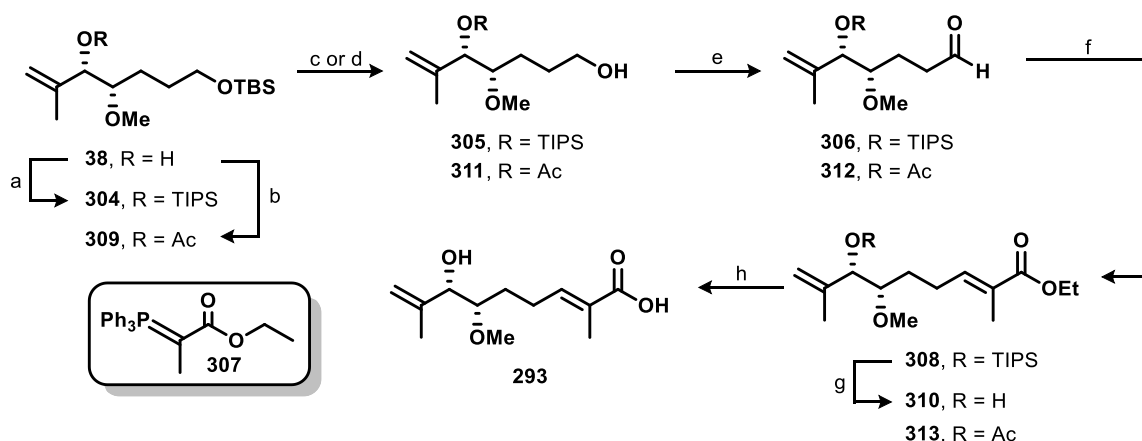

**Scheme 82:** Preparation of acid **293**. Conditions: a) TIPSOTf, 2,6-lutidine, CH<sub>2</sub>Cl<sub>2</sub>, 0 °C to rt, 18 h, 91%; b) Ac<sub>2</sub>O, pyridine, DMAP, rt, 18 h, 78%; c) PPTS, EtOH/H<sub>2</sub>O (9:1), rt, 18 h, 53% for **305**; d) TBAF, THF, 0 °C to rt, 4 h, 85%, for **311**; e) (COCl)<sub>2</sub>, DMSO, CH<sub>2</sub>Cl<sub>2</sub>, -78 °C, 15 min then **305** or **311**, -78 °C, 1.5 h then Et<sub>3</sub>N, -78 °C to rt, yield n.d. for **306**, 88% for **312**; f) **307**, CDCl<sub>3</sub>, 50 °C, 18 h, 76% o2s for **308**, 71% for **313**; g) TBAF, THF, 0 °C, 4 h, 79%; h) LiOH (1.0 M, aq.), THF/MeOH (1:1), 40 °C, 18 h, 70% from **310**, 72% from **313**.

The decarboxylative ketone synthesis under the above conditions with acid **293** unfortunately did not provide desired ketone **314** in sufficient amounts. The product was detected by HRMS, but after purification the ketone could not be recovered. Therefore, the coupling was repeated and acetamide cleavage was carried out with the crude reaction mixture. In this case, formation of the “carba” pantetheine derivative **287** was again observed by HRMS, but only minimal amounts (0.3 mg, 0.7% o3s) were recovered (Scheme 83). “Carba” pantetheines **285** and **286**, as well as the available amounts of **287** were given to Wiebke Ewert for co-crystallization experiments. However, the results of these very experiments were not yet available at the time of writing this thesis.

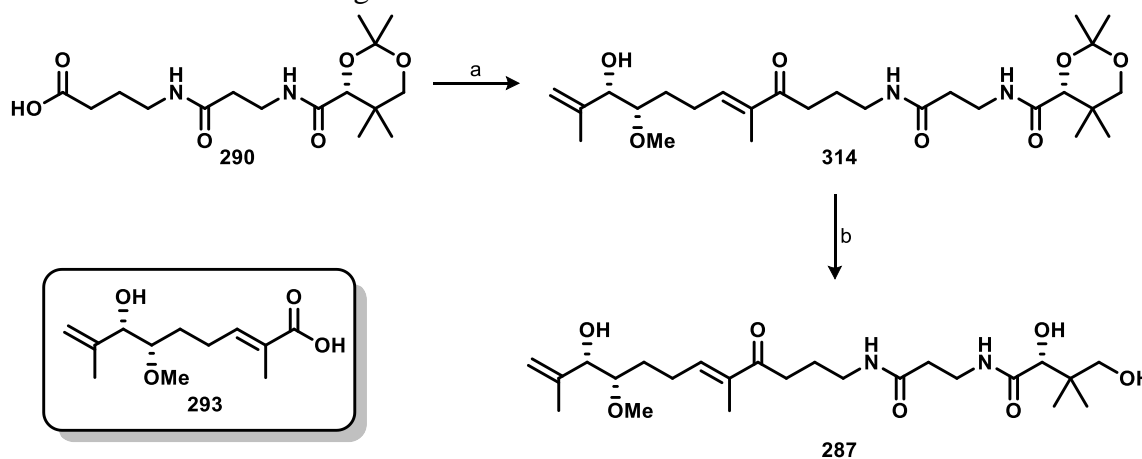

**Scheme 83:** Preparation of “carba” analog **287** by means of decarboxylative ketone formation. Conditions: a) NHPI, DIC, CH<sub>2</sub>Cl<sub>2</sub>, rt, 2 h, solvent change, then **293**, Ni(BPhen)Cl<sub>2</sub>·2DMF (**294**), Zn, benzoic anhydride, MgCl<sub>2</sub>, LiBr, MeCN/THF (1:1.5), rt, 14 h; b) InCl<sub>3</sub>, H<sub>2</sub>O, MeCN, rt, 16 h, 0.7% o2s.

Since the radical decarboxylative ketone formation was not very suitable for the preparation of substantial amounts of “carba” analog **287**, a different strategy was required. A 1,2-addition of a vinyl iodide **325** to aldehyde **316** followed by oxidation was envisioned (Scheme 84).

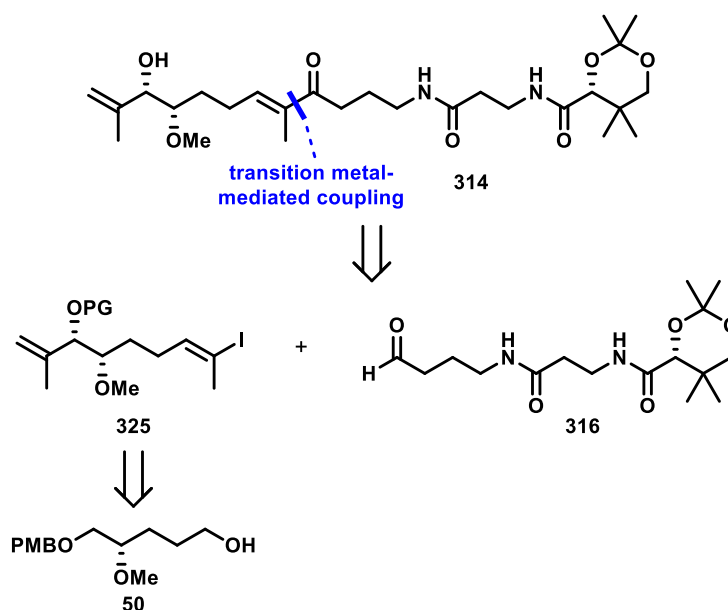

**Scheme 84:** Second retrosynthetic approach towards non-hydrolyzable truncated “carba” analog **314**.

Peptide coupling of D-pantothenic dimethyl ketal (**272**) with 4-amino-1-butanol gave alcohol **317** and oxidation under Swern conditions or employing DMP would furnish required aldehyde **316** (Scheme 85). To avoid undesirable side reactions, aldehyde **316** should not be prepared until the vinyl iodide **325** has been prepared. The synthesis towards vinyl iodide **315** commenced with known primary alcohol **50** (Scheme 85). Oxidation using DMP gave rise to aldehyde **318**. Subsequent Gilbert-Seyferth homologation with Bestmann-Ohira reagent **319** furnished terminal alkyne **320**. Ensuing methylation with *n*-BuLi and MeI gave internal alkyne **321**. The use of a large excess of MeI (15.0 eq.) was necessary to ensure complete consumption of the starting material and to obtain the product in 88% yield. Cleavage of the PMB ether with DDQ resulted in significantly poorer yields here, compared to the PMB deprotection described above for the synthesis of alcohol **53** (page 20). Using ceric ammonium nitrate (CAN) instead, resulted in a very clean reaction furnishing alcohol **322** in 90% yield. Oxidation and subsequent Grignard reaction with *isopropenylmagnesium bromide* yielded allylic alcohol **323**. The aforementioned improved method using the vinylzincate (see page 42), did not work in this case and gave significantly poorer yields. After TBS protection of the allylic alcohol, alkyne **324** should be converted to the corresponding vinyl iodide using Schwartz reagent. This reaction resulted in decomposition to a complex mixture and vinyl iodide **325** could not be isolated. Unfortunately, it was no longer possible within the scope of this work to find suitable conditions for the formation of a vinyl iodide **325** for the planned 1,2-addition towards **314**.

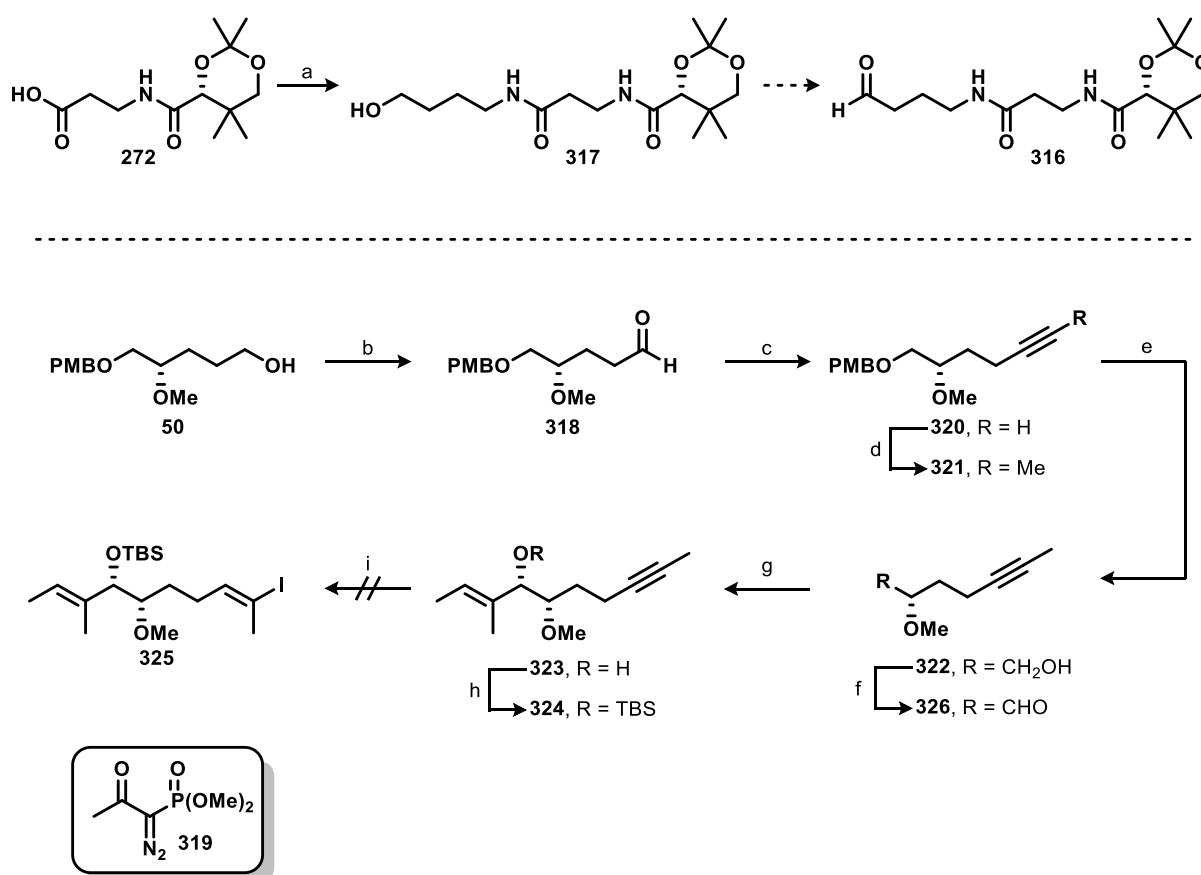

**Scheme 85:** Envisaged preparation of aldehyde **316** and attempted preparation of vinyl iodide **325**. Conditions: a) CDI, THF, rt, 1.5 h, then 4-amino-1-butanol, rt, 48 h, 33%; b) NaHCO<sub>3</sub>, DMP, CH<sub>2</sub>Cl<sub>2</sub>, 0 °C to rt, 1 h, 93%; c) **319**, K<sub>2</sub>CO<sub>3</sub>, MeOH, rt, 18 h, 66%; d) *n*-BuLi, THF, -78 °C, 1 h, then MeI, -78 °C, 20 min, 0 °C, 30 min, rt, 30 min, 88%; e) CAN, MeCN/H<sub>2</sub>O (9:1), rt, 2.5 h, 90%; f) (COCl)<sub>2</sub>, DMSO, CH<sub>2</sub>Cl<sub>2</sub>, -78 °C, 15 min then **322**, -78 °C, 1.5 h then Et<sub>3</sub>N, -78 °C to rt, 76%; g) *isopropenylmagnesium bromide*, THF, -78 °C, 30 min, 38%, *d.r.* = 6:1; h) TBSOTf, 2,6-lutidine, CH<sub>2</sub>Cl<sub>2</sub>, 0 °C, 1 h, 50%; i) Cp<sub>2</sub>ZrHCl, THF, 50 °C, 1 h, then I<sub>2</sub>, -78 °C, 1 h.

## 4 Summary and Outlook

To investigate the substrate flexibility of the amide synthase GdmF, which plays a crucial role in the biosynthesis of geldanamycin, a synthetic approach to the SNAC ester of the enzyme's natural substrate *seco*-progeldanamycin (**30**) was sought (Figure 8).

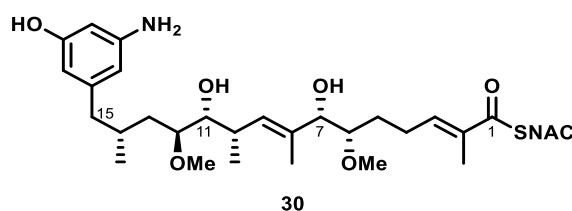

**Figure 8:** Structure of *seco*-progeldanamycin SNAC ester (**30**).

A first generation synthesis featuring a RCM of western fragment **39** and eastern fragment **38** should give rise to the central ene-1,5-diol motif (C-7 to C-11) (Scheme 86). The two required fragments were synthesized according to protocols developed in our group.<sup>[75,79,80,182]</sup> Inspired by the work of Matsui *et al.*<sup>[82,90]</sup> the fragments should be connected by a silicon-based tether,

but installation of the tether on the homoallylic alcohol of the western fragment was not feasible. Addition of succinic anhydride to eastern fragment **38** and subsequent Steglich esterification of the resulting acid with western fragment **39** successfully furnished tethered diene **90**. However, the ensuing RCM with various metathesis catalysts did not lead to the formation of the desired trisubstituted double bond.

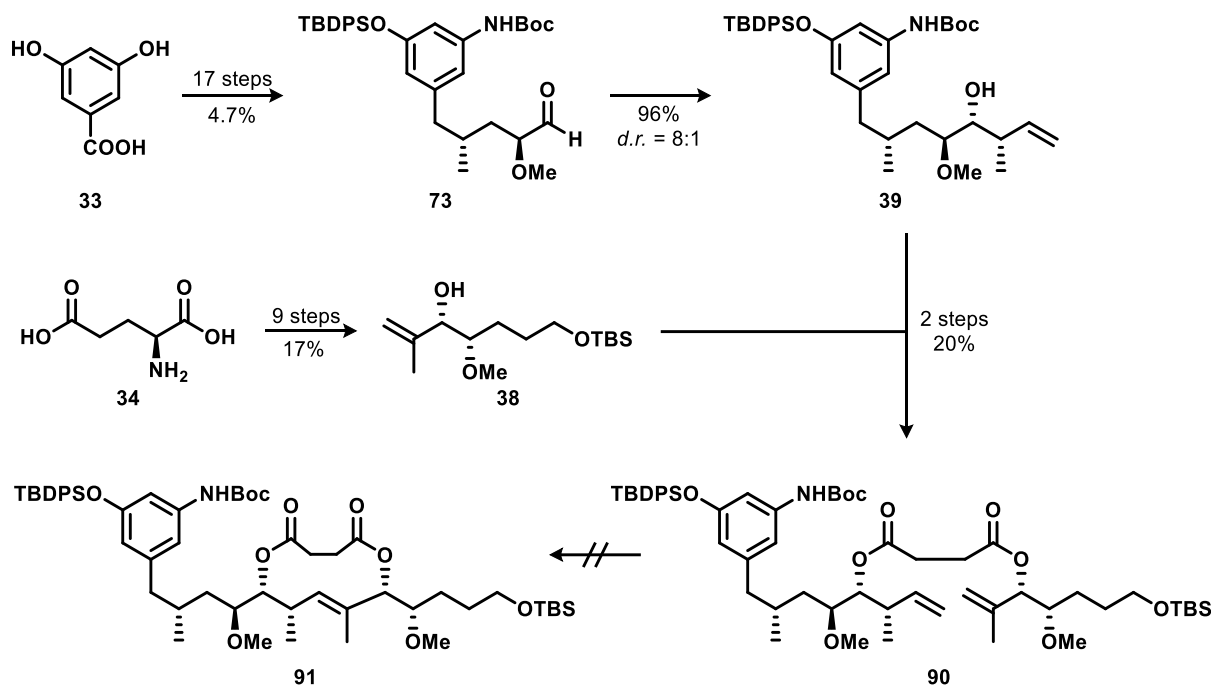

**Scheme 86:** Successful synthesis of western fragment **39** and eastern fragment **38**.<sup>[75,79,80,182]</sup> Attempted ring-closing metathesis (RCM) using various metathesis catalysts did not give rise to the desired trisubstituted double bond in **91**.

The trisubstituted double bond was then envisaged to be introduced by transition metal-mediated coupling of vinyl iodide **97** and aldehyde **54**. An *anti,syn*-selective Marshall propargylation with aldehyde **73** was developed, giving rise to alkyne **98** (*d.r.* = 4:1). A hydrozirconation-iodination sequence should then provide the desired vinyl iodide. Protection of the homopropargylic alcohol was not feasible. The unprotected homopropargylic alcohol, however, coordinated to the zirconium species resulting in a 1:1-mixture of regioisomers of the vinyl iodide (Scheme 87). Due to the linearity of the synthesis and low yields, alkyne **98** was hardly provided in preparative useful yields (1% over 18 steps longest linear sequence) to carry out further investigations for the fragment coupling. Attempts to streamline the synthesis by means of a Myers alkylation to introduce the C-12 methoxy group, which would reduce the number of steps by six, did not work out as planned.

Therefore, a more convergent second generation synthesis was developed in which the aromatic moiety should be introduced at a later stage. This new approach required alkyne **122** as the central fragment, which was readily available starting from (*R*)-Roche ester in only 7 steps using aforementioned Myers alkylation and an improved Marshall propargylation (*d.r.* = 6:1) as key steps. Protection of this homopropargylic alcohol was straightforward and subsequent hydrozirconation-iodination yielded vinyl iodide **135** in 17% overall yield over 9 steps.

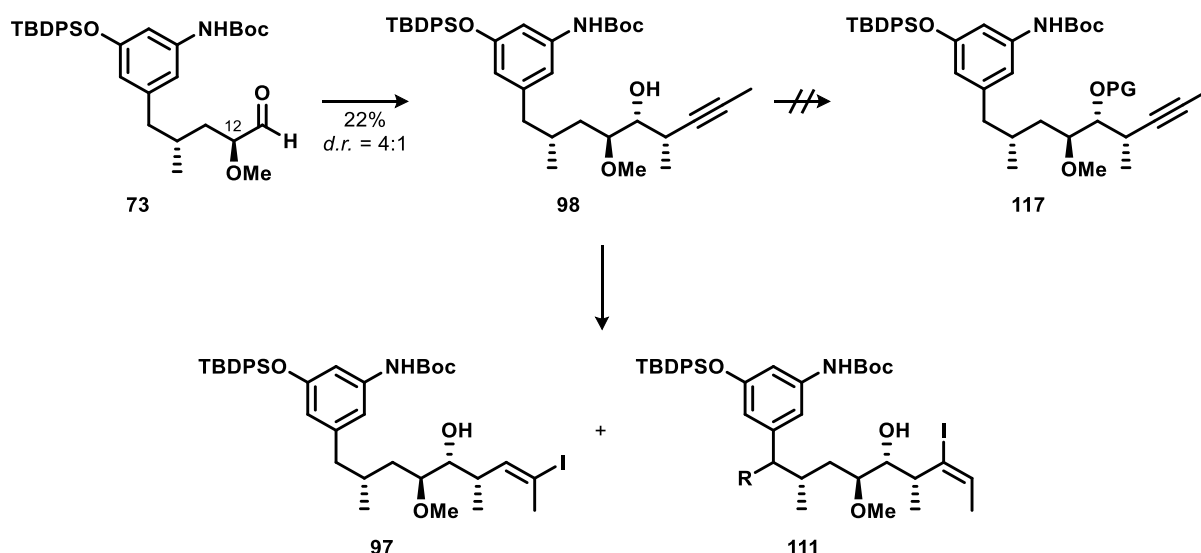

**Scheme 87:** Successful *anti,syn*-selective Marshall propargylation. Hydrozirconation-iodination of **98** gave a mixture of regioisomers (**97**:**111** = 1:1). Protection of the homopropargylic alcohol was not feasible.

An enantioselective NHK coupling with aldehyde **54** would give rise to the ene-1,5-diol motif but all attempts were unsuccessful. An achiral NHK furnished an inseparable 1:1-mixture of diastereomers of **142** in 26% yield (Scheme 88). Oxidation and CBS-reduction of the resulting enone was not stereoselective, yielding the same diastereomeric mixture (*d.r.* = 1:1) of the enol as before oxidation. Halogen-metal exchange of the vinyl iodide and subsequent 1,2-addition to aldehyde **54** or the titanium alkoxide-mediated reductive coupling of alkyne **122** to aldehyde **54** also did not lead to satisfactory results.

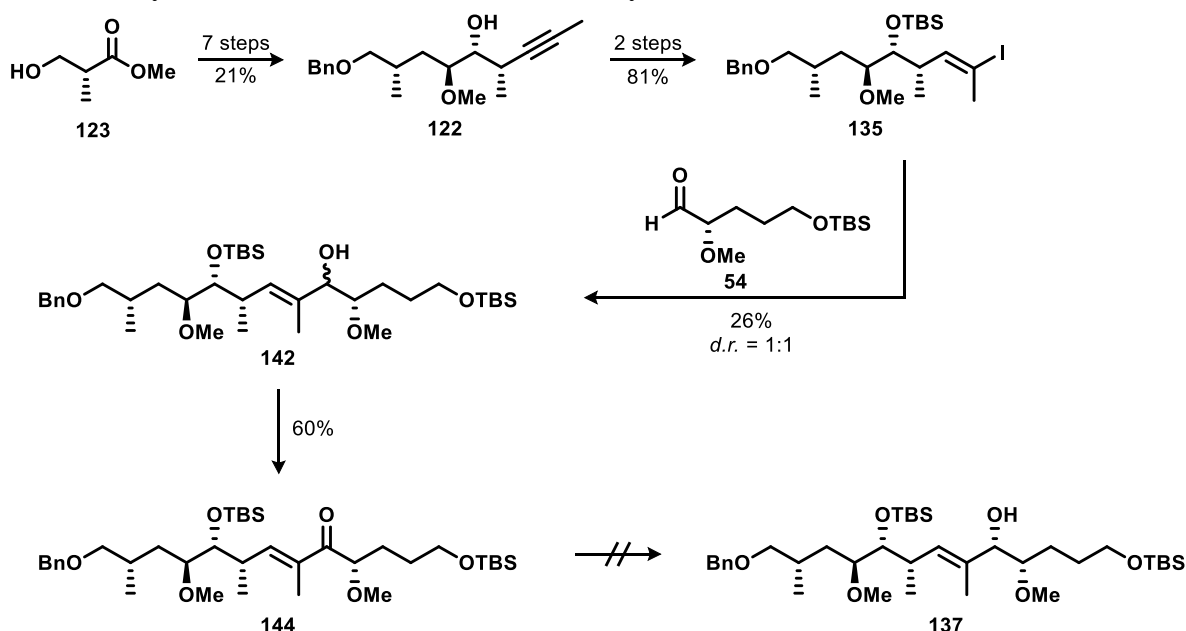

**Scheme 88:** Preparation of vinyl iodide **135** from (*R*)-Roche ester (**123**) and subsequent achiral NHK coupling with aldehyde **54** gave rise to allylic alcohol **142**. An enantioselective NHK coupling did not provide allylic alcohol **142**. Oxidation of **142** provided enone **144**, but subsequent CBS reduction of the enone suffered from low diastereoselectivity.

Focus was then turned on the introduction of the aromatic moiety, which was envisaged by C(sp<sup>2</sup>)-C(sp<sup>3</sup>) cross-coupling. Various coupling conditions were investigated. However, Suzuki and Kumada coupling and nickel-catalyzed reductive coupling of an alkyl bromide

and an aryl bromide were not successful in introducing the aromatic to a satisfactory extent. In all of the cross-couplings,  $\beta$ -elimination was predominant. The arene was then successfully introduced by a lithiation-borylation-protodeboronation but the products could not be recovered in useful yields. Instead, the 1,2-addition of an aryl lithiate to an aldehyde proved to be a reliable method for the introduction of the arene. After some protection group modifications, 1,2-addition of arene **230** to aldehyde **246** and subsequent Barton-McCombie deoxygenation gave rise to **247** (Scheme 89). Unfortunately, the previously established hydrozirconation-iodination sequence was not feasible with alkyne **247** as the allyl protection groups of the aniline were reduced under these conditions. Therefore, fragment coupling must occur before the arene is introduced. The ensuing 1,2-addition and Barton-McCombie deoxygenation are expected to perform equally well. Unfortunately, the experiments on this could not be carried out within the scope of this thesis.

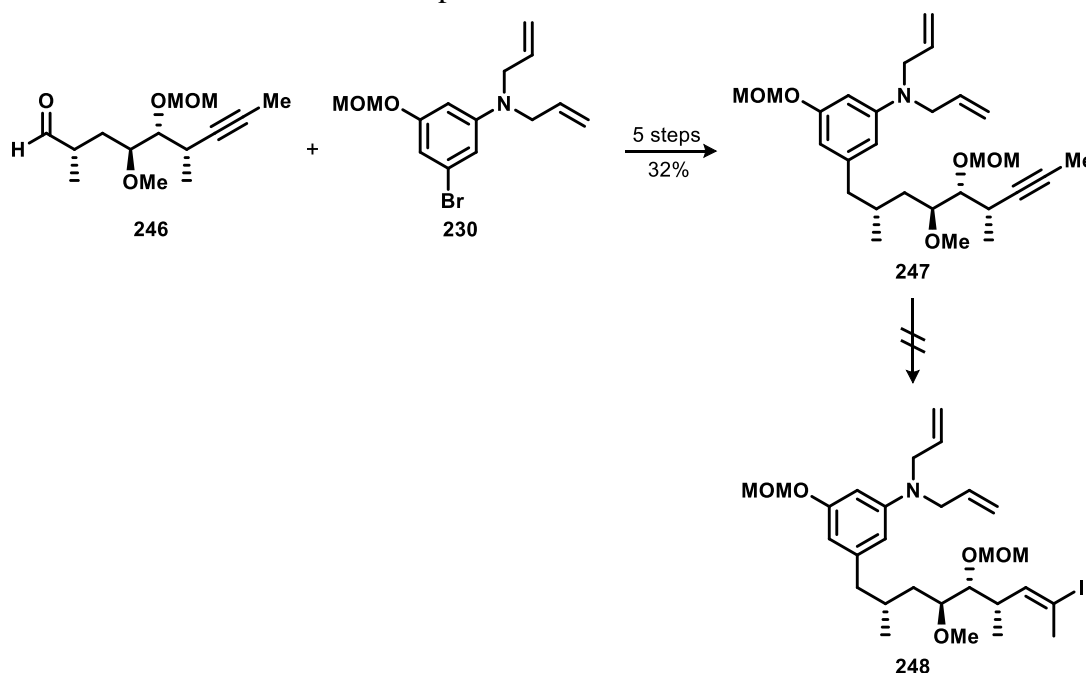

**Scheme 89:** Introduction of the aromatic moiety by 1,2-addition and subsequent Barton-McCombie deoxygenation.

By introducing the aromatic moiety at a later stage, the synthesis became much more convergent compared to the first generation and can be performed more easily and reliably. The introduction of the alcohol at C-7 proved to be a major challenge. At the present time, the synthesis for this lacks a powerful diastereoselective method. Here, the stereoselective reduction of the respective enone appears to be the most promising approach for future studies. However, due to the low yields of the NHK coupling, an alternative access to enone **142** would be necessary. In fact, at the very end of this thesis, experiments were still carried out to study the  $\text{SmI}_2$ -mediated Reformatsky reaction of aldehyde **254** and  $\alpha$ -bromoketone **257** (Scheme 90).

This furnished  $\beta$ -hydroxy ketone **258** and subsequent dehydration using Martin's sulfurane yielded enone **259**. Due to time constraints and stability issues of  $\alpha$ -bromoketone **257**, the resulting  $\beta$ -hydroxy ketone **258** and enone **259** could not be isolated in sufficient amounts for NMR analysis, but were detected only by HRMS. Although the yields of the last two transformations could not be determined, it would be very useful to make further efforts toward this strategy. This sequence requires one additional step to give the enone, compared

to the NHK approach, but especially the high yield and diastereoselectivity of the Roush crotylation (68%, *d.r.* = 17:1) make this approach highly interesting.

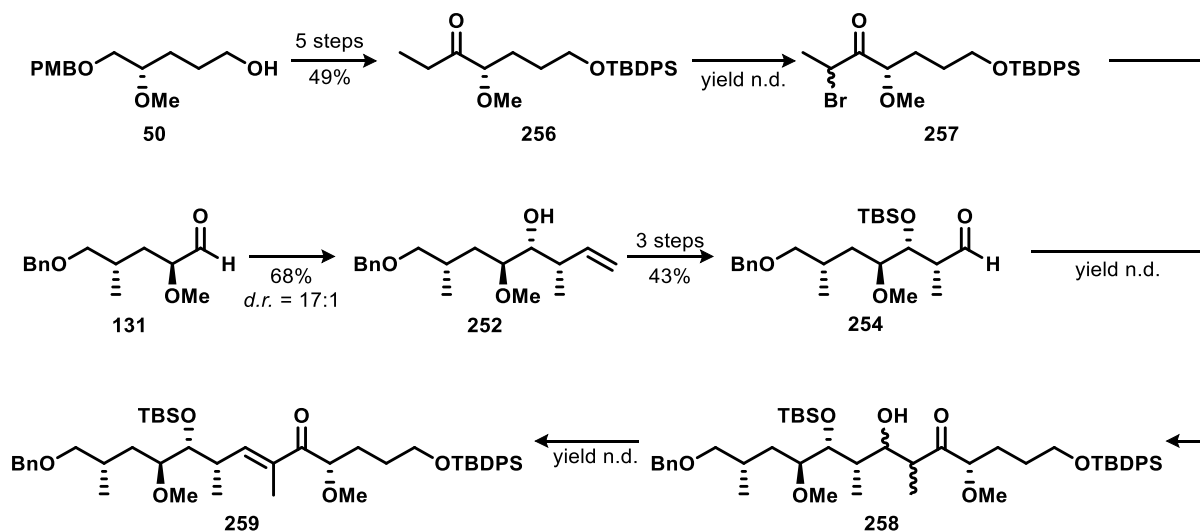

**Scheme 90:** SmI<sub>2</sub>-mediated Reformatsky reaction giving rise to enone **259**.

In conclusion, based on the studies conducted in this work, the synthetic challenges encountered and the knowledge gained, a synthesis can be formulated that would allow access to *seco*-progeldanamycin SNAC ester **260** in 25 steps (Scheme 91).

Preparation of aldehyde **327**,  $\alpha$ -bromoketone **257** and the ensuing Reformatsky reaction will occur as described above to furnish enone **328**. After stereoselective reduction of enone **328** and protection of the resulting alcohol, debenzylation by means of LiDBB, oxidation and 1,2-addition of arene **230** according to the above established protocols will give rise to **329**. The primary silyl ether will be selectively removed and oxidized to the corresponding aldehyde. Subsequent Wittig olefination will install the SNAC ester (**330**). The synthesis will then be finalized by cleavage of the MOM ethers and the allyl groups yielding the final SNAC ester of *seco*-progeldanamycin **30**.

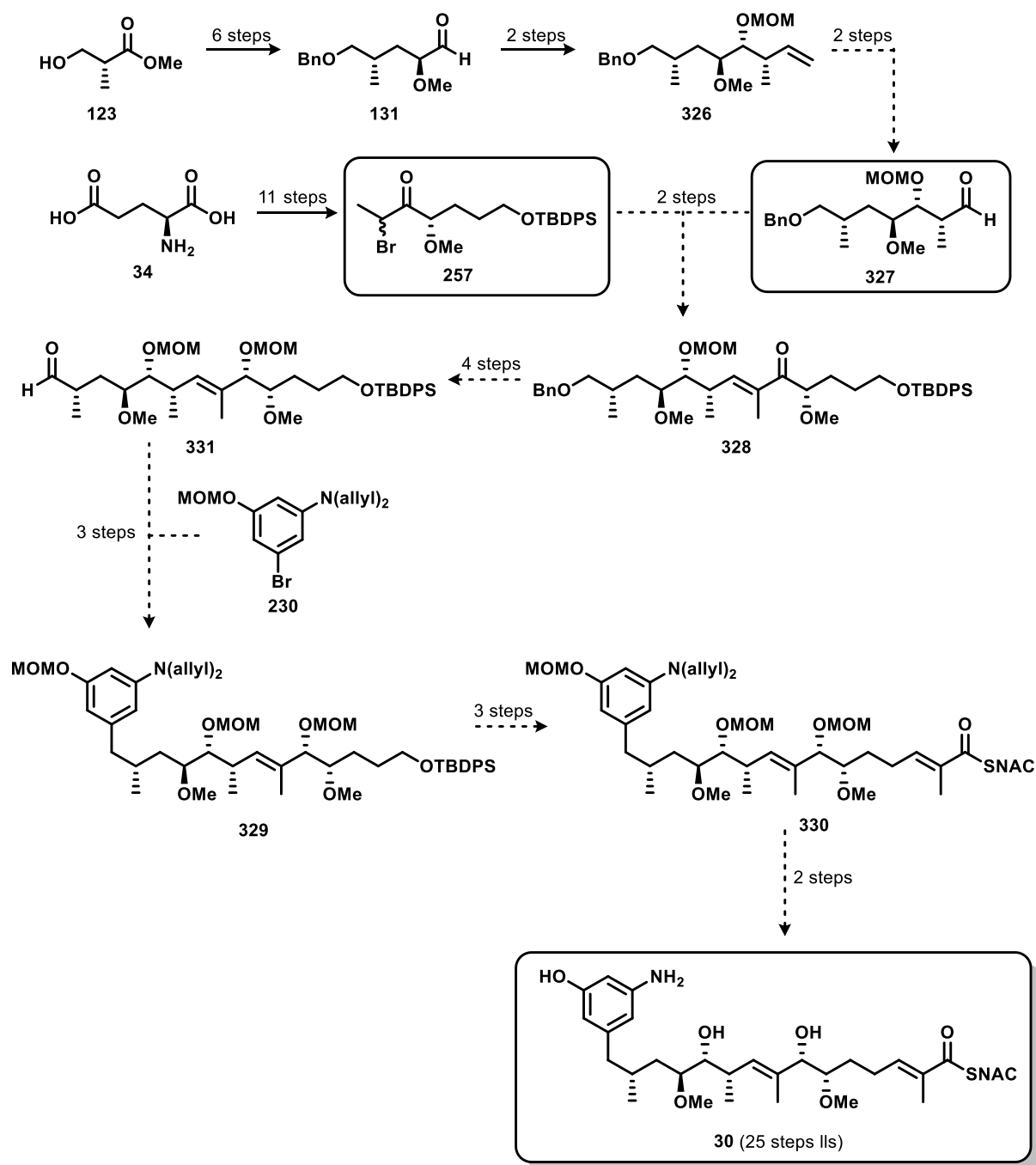

**Scheme 91:** Successful preparation of alkene **326** and  $\alpha$ -bromoketone **257** (plain arrows) and future directions (dotted arrows) for the synthesis of *seco*-progeldanamycin SNAC ester **30**.

Besides studies towards *seco*-progeldanamycin SNAC ester **30**, truncated substrates were synthesized and used in activity assays and co-crystallization experiments with GdmF. The latter were performed by Wiebke Ewert. These substrates included three SNAC esters **267-269** and three pantetheines **277-279**, as well as aniline **264** and commercially available aniline **266** (Scheme 92).



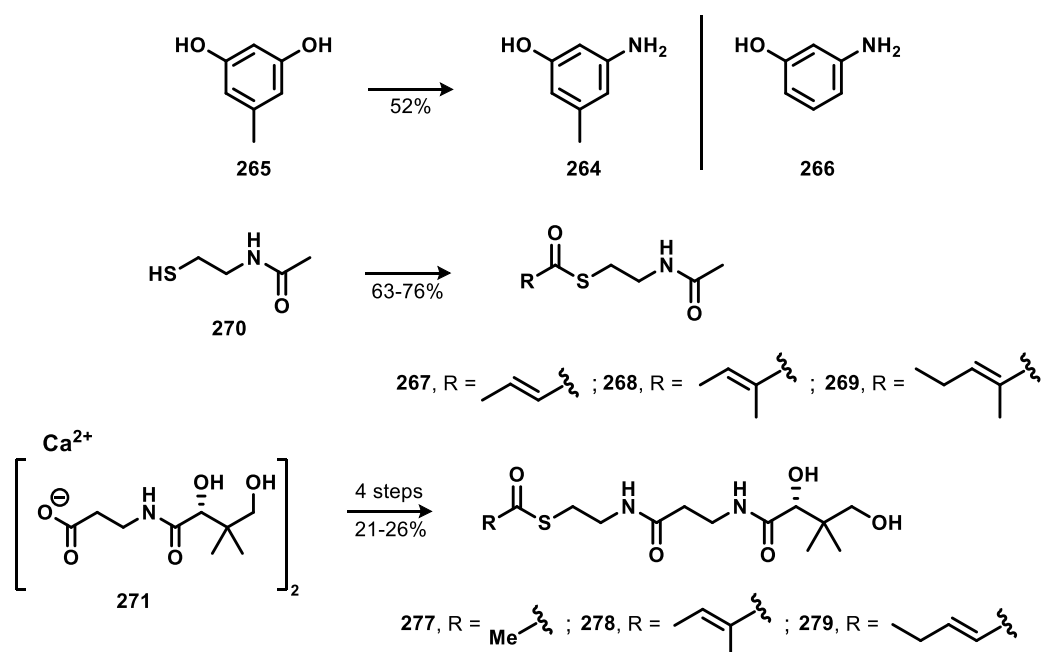

**Scheme 92:** Synthesis of truncated test substrates used for co-crystallization experiments with GdmF.

The results of the biochemical experiments suggested that GdmF is capable of catalyzing the first step of macrolactamization by directly binding the substrates, even in the absence of the aniline. As this catalytic activity is accompanied with the hydrolysis of the thioester substrates, non-hydrolyzable substrates were also synthesized to be able to generate crystallographic structures that would reveal details about the orientation and coordination of the ketide chain in the active site.

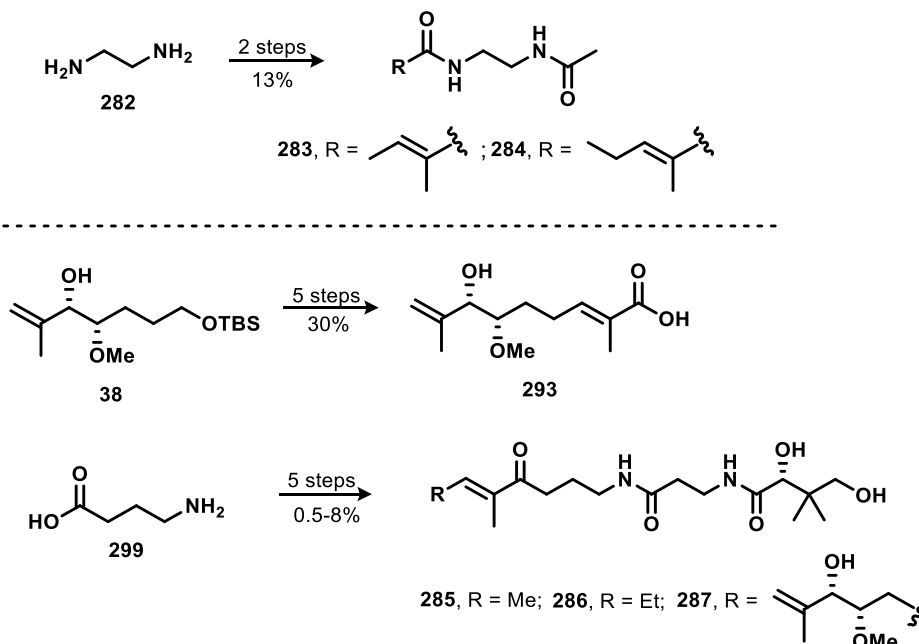

**Scheme 93:** Preparation of amido SNAC and “carba” pantetheine substrates for co-crystallization experiments with GdmF.

The co-crystallization experiments with amido analogs **283** and **284** did not provide useful results. Therefore, “carba” analogs **285**, **286** and **287** were successfully prepared by decarboxylative ketone formation (Scheme 93).

Since this approach did only perform poorly for the preparation of the more advanced “carba” analog **287** a different strategy featuring a transition metal-mediated coupling was envisaged. Starting from alcohol **50** alkyne **324** was prepared in a short 7 step sequence (Scheme 94, A). The hydrozirconation followed by iodination did not provide vinyl iodide **325**. Further studies towards **325** could not be carried out in the course of this thesis. The results of the co-crystallization experiments with “carba” analogs were not present at the time of writing this thesis. The envisaged transition metal-mediated coupling not only offers the possibility for the synthesis of truncated “carba” analog **287**, but would also be suitable for the synthesis of a “carba” pantetheine analog of *seco*-progeldanamycin (**332**). An approach based on a Wittig olefination using phosphonium ylene **333** is regarded as a promising alternative (Scheme 94, B). Further studies in this direction are recommended as co-crystallization experiments with substrates **287** and **332** would provide tremendous insight into the chemical environment in the active site of GdmF.

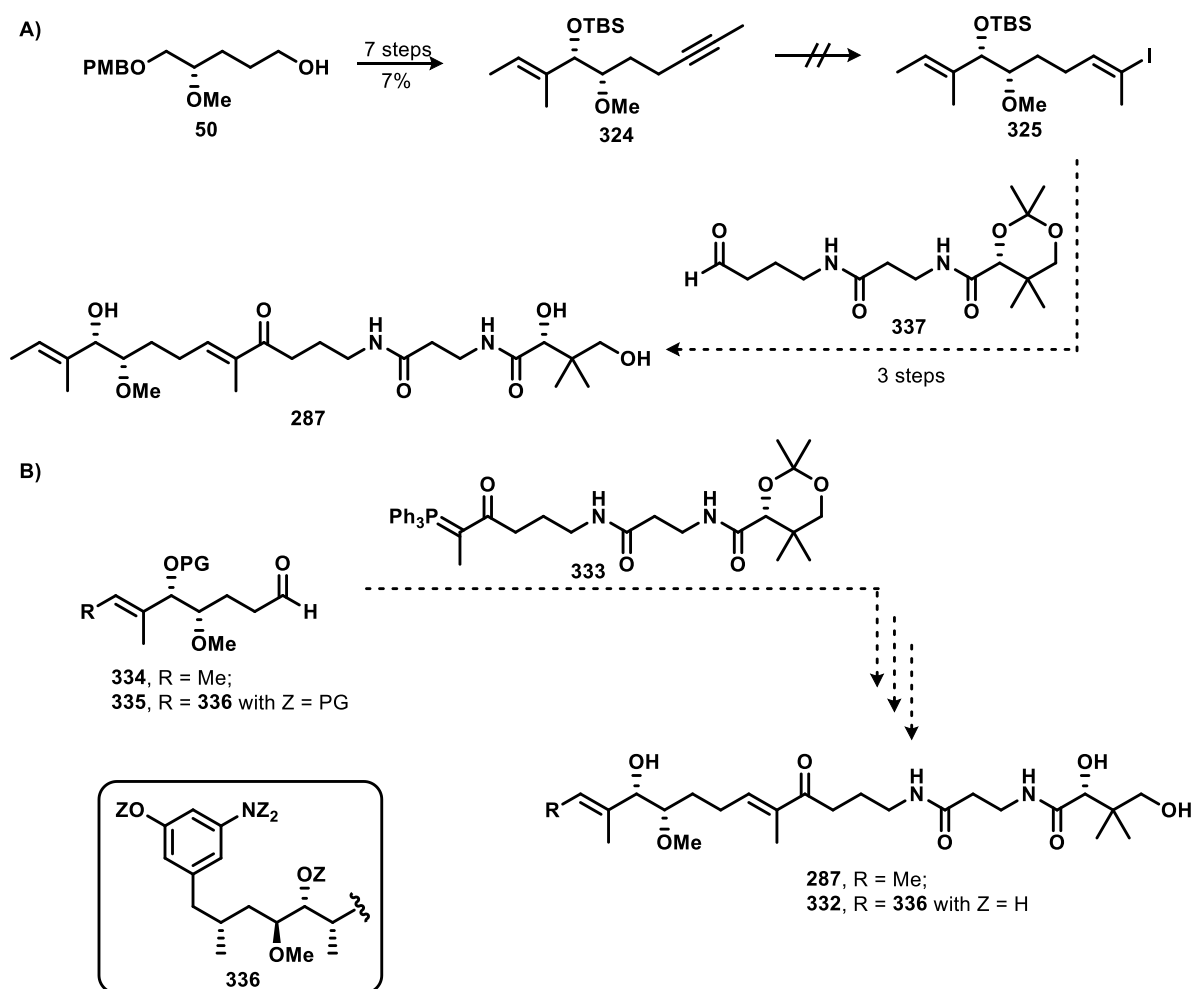

**Scheme 94:** A) Successful preparation of alkyne **324** and attempted synthesis of vinyl iodide **325** for the preparation of truncated “carba” pantetheine **287**. B) Wittig olefination as an alternative for the preparation of “carba” analogs.

## 5 Experimental Part

### 5.1 General Information

Reactions with moisture- or air-sensitive reagents were carried out in an inert gas atmosphere. The glassware used was previously dried by bake-out in a vacuum.

#### Solvents and Reagents

Dry solvents ( $\text{CH}_2\text{Cl}_2$ , MeCN, DMF,  $\text{Et}_2\text{O}$ ) were taken from the solvent purification system (SPS by MBraun). THF was freshly distilled over sodium and benzophenone.  $\text{Et}_3\text{N}$  and DIPA were freshly distilled over KOH. Other commercially available solvents were purchased from Sigma-Aldrich or Acros. Reagents whose preparation is not described below were purchased from ABCR, Acros, Alfa Aesar, Carbolution, Fluorochem, Sigma-Aldrich, Strem or TCI. Deuterated solvents for NMR were purchased from Deutero.

#### Flash Column Chromatography

The silica gel used for manual flash column chromatography was acquired from Macherey-Nagel (type 60 M, grain size 40 – 63  $\mu\text{m}$ ). Automated flash column chromatography was conducted with the flash purification system Sepacore<sup>®</sup> by Buchi using prepacked cartridges (puriFlash<sup>®</sup> by Interchim or chromabond<sup>®</sup> by Macherey-Nagel). The eluents are given in brackets.

#### Thin Layer Chromatography

For TLC aluminum plates coated with silica gel, type 60 F254 by Merck, were used and the spots were visualized with UV light ( $\lambda = 254 \text{ nm}$ ) or alternatively by staining with vanillin, anisaldehyde, ceric ammonium sulfate or potassium permanganate solutions.

#### NMR-Spectroscopy

$^1\text{H}$  NMR and  $^{13}\text{C}$  NMR spectra were recorded with the Ascend 600 MHz with Avance Neo console, Ultrashield 500 MHz with Avance-III HD console, Ascend 400 MHz with Avance-III console, Ascend 400 MHz with Avance-III HD console or Ultrashield 400 MHz with Avance-I console by Bruker at 298 K. The spectra were analyzed using the software TopSpin by Bruker. The chemical shifts ( $\delta$ ) are reported in ppm and the calibration was conducted by using the residual proton peak of the solvent. The coupling constants  $J$  are reported in Hz and the multiplicities are described with the following abbreviations:

$^1\text{H}$ -NMR: s = singlet, d = doublet, t = triplet, dd = doublet of doublets, bs = broad singlet.

$^{13}\text{C}$  NMR: the multiplicities are corresponding to the non-decoupled spectra the signals, s = quaternary C-atom, d = tertiary C-atom, t = secondary C-atom, q = primary C-atom.

For the assignment of the signals 2-D experiments (COSY, HMBC, HSQC) were conducted.

#### Optical rotations

Specific optical rotation values  $[\alpha]_D^T$  were measured with a Perkin-Elmer Spectrum 241 polarimeter at  $\lambda = 589 \text{ nm}$  (sodium D line) and the temperature  $T$ . A glass cuvette with a

volume of 1 mL and a length of 1 dm was used. The value of the specific rotation is given in  $[\alpha]_{\text{D}}^{20}$ , the concentration  $c$  is given in  $[\text{10 mg}\cdot\text{mL}^{-1}]$ .

### Melting Points

Melting points were determined with an OptiMelt MPA100 by Stanford Research Systems.

### Mass Spectrometry

High resolution mass spectra (HRMS) were recorded with a Micromass LCT with a *lockspray* dual ion source in combination with a Waters Alliance 2695 system. Injection was conducted in loop mode. Alternatively, a QTOF premier spectrometer (Waters) in combination with a Waters Acquity UPLC system was used. Ionization was carried out via electrospray-ionization (ESI). The calculated and the detected masses are reported.

## 5.2 Auxiliary Reagents and Building Blocks

### (S)-4-Benzyl-3-Propionyloxazolidin-2-one (**59**)

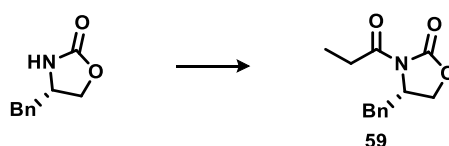

(S)-4-Benzyloxazolidin-2-one (13.40 g, 75.64 mmol, 1.0 eq.) was dissolved in dry THF (40 mL) and was cooled to  $-78\text{ }^{\circ}\text{C}$ . *n*-BuLi (1.6 M in hexane, 52.0 mL, 83.21 mmol, 1.1 eq.) was added dropwise and stirring was continued for 10 min. Subsequently, propionyl chloride (7.26 mL, 83.21 mmol, 1.1 eq.) was added slowly and stirring was continued at  $-78\text{ }^{\circ}\text{C}$  for 1 h. The yellow solution was allowed to reach room temperature and the reaction was terminated by adding an aqueous saturated  $\text{NH}_4\text{Cl}$  solution. The excess of THF was removed under reduced pressure and the aqueous phase was extracted with  $\text{CH}_2\text{Cl}_2$  (3 x 10 mL). The combined organic phases were washed with an aqueous 1 M NaOH solution, brine and dried over  $\text{MgSO}_4$  and filtered. The solvent was removed under reduced pressure. The crude product was purified by flash column chromatography (PE/EtOAc = 6:1  $\rightarrow$  4:1) to yield (S)-4-benzyl-3-propionyloxazolidin-2-one (**59**, 16.04 g, 68.76 mmol, 91%) as a colorless crystalline solid.

The analytical data are consistent with those reported in the literature.<sup>[183]</sup>

$R_f = 0.5$  (PE/EtOAc = 4:1);

**$^1\text{H-NMR}$**  (400 MHz,  $\text{CDCl}_3$ ,  $\text{CHCl}_3 = 7.26$  ppm):  $\delta$  7.31 – 7.20 (m, 3H, Bn), 7.17 – 7.15 (m, 2H, Bn), 4.65 – 4.59 (m, 1H, H-4), 4.17 – 4.10 (m, 2H, H-5), 3.25 (dd,  $J = 13.4, 3.3$  Hz, 1H, Bn), 2.99 – 2.82 (m, 2H,  $\text{CH}_2\text{CH}_3$ ), 2.72 (dd,  $J = 13.4, 9.6$  Hz, 1H, Bn), 1.56 (t,  $J = 7.3$  Hz, 3H,  $\text{CH}_3$ ) ppm;

**$^{13}\text{C-NMR}$**  (400 MHz,  $\text{CDCl}_3$ ,  $\text{CDCl}_3 = 77.16$  ppm):  $\delta$  174.2 (s,  $\text{COCH}_2\text{CH}_3$ ), 153.6 (s, C-2), 135.5 (s, Bn), 129.5 (d, 2C, Bn), 129.1 (d, Bn), 127.4 (d, Bn), 66.3 (t, C-5), 55.3 (d, C-4), 38.0 (t, Bn), 29.3 (t,  $\text{CH}_2\text{CH}_3$ ), 8.4 (q,  $\text{CH}_3$ ) ppm;

$[\alpha]_{\text{D}}^{20} = +91.0$  ( $c = 1.0$ , EtOH; lit.  $[\alpha]_{\text{D}}^{20} = +92.9$ ,  $c = 1.01$ , EtOH)<sup>[183]</sup>;

**m.p.** 44 – 45 °C (lit. 43 – 46 °C)<sup>[183]</sup>;

**HRMS-ESI**  $m/z$  for  $C_{13}H_{15}NO_3Na$   $[M+Na]^+$  calc. 256.0950, found 256.0950.

**(1*S*,2*S*)-(-)-*N*-Tosyl-1,2-diphenylethane-1,2-diamine[( $\eta^6$ -1-isopropyl-4-methylbenzene)ruthenium (II)] (Noyori Catalyst, (*S*)-338)**

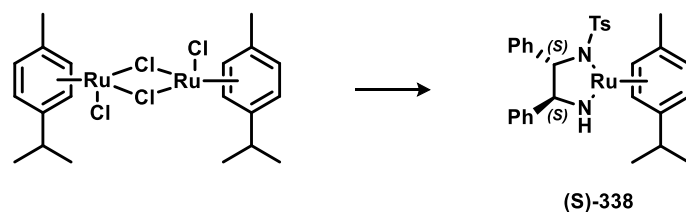

According to the procedure published by Baldwin *et al.*<sup>[184]</sup> a mixture of di- $\mu$ -chloro-bis[chloro( $\eta^6$ -1-isopropyl-4-methyl-benzene)ruthenium (II)] (153 mg, 0.250 mmol, 1.0 eq.), *N*-((1*S*,2*S*)-2-amino-1,2-diphenylethyl)-4-methyl-benzenesulfonamide (183 mg, 0.50 mmol, 2.0 eq.) and KOH (210 mg, 3.75 mmol, 15.0 eq.) in  $CH_2Cl_2$  (4 ml) was stirred at room temperature for 5 min. The reaction was terminated by the addition of water and a color change from orange to deep purple was observed. The phases were separated and the organic phase was washed with water, dried over  $CaH_2$  and the solvent was removed under reduced pressure to yield (*S,S*)-Noyori catalyst (*S*)-338 (121 mg, 0.203 mmol, 81%) as deep purple crystals. The catalyst was used in the next step without further purification and analysis.

**Pent-3-yn-2-ol (104)**

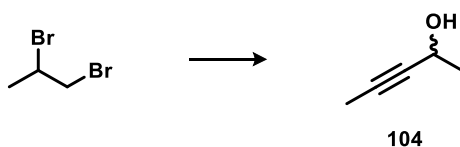

According to the procedure published by Gribble *et al.*<sup>[98]</sup> DIPA (35.5 mL, 252.4 mmol, 3.3 eq.) was dissolved in THF (200 mL) and cooled to  $-78$  °C. *n*-BuLi (2.5 M in hexane, 101.0 mL, 252.4 mmol, 3.3 eq.) was added carefully and the reaction was warmed to  $-50$  °C and stirred at this temperature for 30 min. After cooling to  $-78$  °C again, 1,2-dibromopropane (8.0 mL, 76.48 mmol, 1.0 eq.) was added slowly. The orange solution was then stirred at 0 °C for 5 min before it was cooled to  $-78$  °C and freshly distilled acetaldehyde (5.6 mL, 99.42 mmol, 1.3 eq.) was added. Stirring was continued for 30 min. The reaction was terminated by the addition of a saturated aqueous  $NH_4Cl$  solution. The phases were separated and the aqueous phase was extracted with  $Et_2O$  (3 x 50 mL). The combined organic phases were washed with brine, dried over  $MgSO_4$ , filtered and the solvent was removed under reduced pressure. The crude product was purified by vacuum distillation to yield pent-3-yn-2-ol (**104**, 4.55 g, 54.09 mmol, 71%) as a colorless oil.

The analytical data are consistent with those reported in the literature.<sup>[98]</sup>

**R<sub>f</sub>** = 0.3 (PE/EtOAc = 4:1);

**<sup>1</sup>H-NMR** (400 MHz,  $CDCl_3$ ,  $CHCl_3$  = 7.26 ppm):  $\delta$  4.51 – 4.45 (m, 1H, OH), 1.83 (d,  $J$  = 2.1 Hz, 3H,  $CCH_3$ ), 1.90 (bs, 1H, CH), 1.41 (d,  $J$  = 6.6 Hz, 3H,  $CHOHCH_3$ ) ppm;

**b.p.** (30 mbar): 55 °C (lit. 50 °C, 20 mbar)<sup>[98]</sup>.

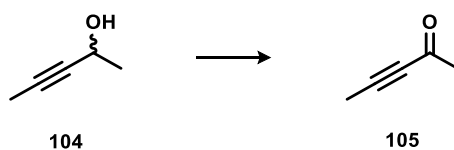
**Pent-3-yn-2-one (105)**

Pent-3-yn-2-ol (**104**, 4.25 g, 50.53 mmol, 1.0 eq.) was dissolved in  $\text{CH}_2\text{Cl}_2$  (250 mL) and  $\text{MnO}_2$  (90.0 g, 1.04 mol, 20.0 eq.) was added. After stirring for 24 h at room temperature, the reaction was filtered through Celite<sup>®</sup> and concentrated under reduced pressure (850 mbar, 40 °C water bath). The rest of the solvent was removed by distillation applying a small Vigreux column (atm. pressure, 75 °C metal bath). Crude volatile ketone **105** was directly used in the next step without further purification.

$R_f = 0.5$  (PE/EtOAc = 4:1);

$^1\text{H-NMR}$  (400 MHz,  $\text{CDCl}_3$ ,  $\text{CHCl}_3 = 7.26$  ppm):  $\delta$  2.30 (s, 3H,  $\text{COCH}_3$ ), 2.00 (s, 3H,  $\text{CCH}_3$ ) ppm.

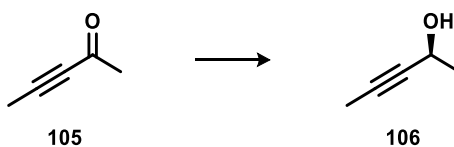
**(S)-Pent-3-yn-2-ol (106)**

Ketone **105** (50.53 mmol, 1.0 eq.) was dissolved *i*-PrOH (250 mL) and (*S,S*)-Noyori catalyst ((*S*)-**338**, 200 mg, 0.33 mmol, 0.7 mol%) in 5 mL  $\text{CH}_2\text{Cl}_2$  was added. The dark orange solution was stirred for 18 h at room temperature. The solvent was removed by distillation (180 mbar, 70 °C metal bath) applying a Vigreux column. The crude product was then purified by distillation (50 mbar, 106 °C metal bath) to furnish (*S*)-pent-3-yn-2-ol **106** (1.42 g, 16.91 mmol, 33% o2s) as a pale yellow oil.

The analytical data are consistent with those reported in the literature.<sup>[113]</sup>

$R_f = 0.3$  (PE/EtOAc = 4:1);

$^1\text{H-NMR}$  (400 MHz,  $\text{CDCl}_3$ ,  $\text{CHCl}_3 = 7.26$  ppm):  $\delta$  4.51 – 4.45 (m, 1H, OH), 1.86 – 1.84 (m, 1H, H-2), 1.83 (d,  $J = 2.1$  Hz, 3H,  $\text{CCH}_3$ ), 1.41 (d,  $J = 6.6$  Hz, 3H,  $\text{CHOHCH}_3$ ) ppm;

$[\alpha]_{\text{D}}^{20} = -33.2$  ( $c = 1.2$ ,  $\text{CHCl}_3$ ; lit.  $[\alpha]_{\text{D}}^{20} = -29.1$ ,  $c = 1.05$ ,  $\text{CH}_2\text{Cl}_2$ )<sup>[113]</sup>;

**b.p.** (50 mbar): 57 – 59 °C (lit. 64 – 66 °C, 66 mbar)<sup>[113]</sup>.

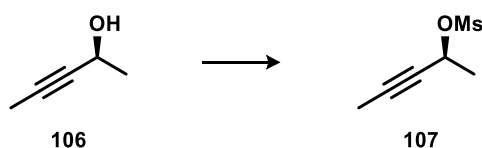
**(S)-Pent-3-yn-2-yl methanesulfonate (107)**

To a solution of (*S*)-pent-3-yn-2-ol (**106**, 0.65 g, 7.67 mmol, 1.0 eq.) and freshly distilled Et<sub>3</sub>N (2.13 mL, 15.34 mmol, 2.0 eq.) in CH<sub>2</sub>Cl<sub>2</sub> (30 mL), MsCl (0.89 mL, 11.50 mmol, 1.5 eq.) was added slowly at  $-78\text{ }^{\circ}\text{C}$ . After stirring for 1 h the reaction was terminated by the addition of a saturated aqueous NaHCO<sub>3</sub> solution. The mixture was allowed to reach room temperature and the phases were separated. The aqueous phase was extracted with Et<sub>2</sub>O (3 x 25 mL) and the combined organic phases were dried over MgSO<sub>4</sub>, filtered and concentrated under reduced pressure. The configuratively instable mesylate **107** was obtained as a pale yellow oil and was directly used in the next step without further purification.

**<sup>1</sup>H-NMR** (400 MHz, CDCl<sub>3</sub>, CHCl<sub>3</sub> = 7.26 ppm):  $\delta$  5.28 – 5.24 (m, 1H, CH), 3.1 (s, 3H, Ms), 1.88 (d,  $J$  = 2.1 Hz, 3H, Me), 1.61 (d,  $J$  = 6.6 Hz, 3H, Me) ppm.

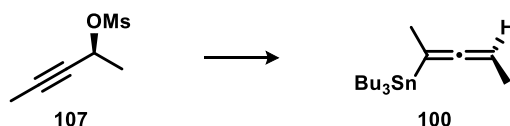
**(*R<sub>a</sub>*)-Tributyl(penta-2,3-dien-2-yl)stannane (100)**

DIPA (2.26 mL, 16.10 mmol, 2.1 eq.) was dissolved in freshly distilled THF (35 mL) and cooled to  $0\text{ }^{\circ}\text{C}$ . *n*-BuLi (1.6 M in hexane, 9.58 mL, 15.34 mmol, 2.0 eq.) was added slowly and the reaction was stirred for 30 min at this temperature. Then HSnBu<sub>3</sub> (3.85 mL, 14.57 mmol, 1.9 eq.) was added dropwise and after stirring for 30 min at  $0\text{ }^{\circ}\text{C}$  the reaction was cooled to  $-50\text{ }^{\circ}\text{C}$  and CuBr·SMe<sub>2</sub><sup>8</sup> (3.0 g, 14.57 mmol, 1.9 eq.) was added. The reaction was stirred for another 30 min before mesylate **107** (7.67 mmol, 1.0 eq.) dissolved in THF (20 mL) was added dropwise. Stirring was continued and the reaction was allowed to reach  $-10\text{ }^{\circ}\text{C}$  over a period of 1.5 h. The solution was then poured into a rapidly stirred solution of NH<sub>4</sub>Cl/NH<sub>3</sub> (9:1, 200 mL) and Et<sub>2</sub>O (100 mL). Once the organic phase clarified it was separated, dried over MgSO<sub>4</sub>, filtered and concentrated under reduced pressure. The resulting oil was purified by column chromatography using basic alumina end eluting with PE. Further purification was conducted by Kugelrohr distillation ( $145\text{ }^{\circ}\text{C}$ , 5 mbar) to furnish (*R<sub>a</sub>*)-allenylstannane **100** (2.02 g, 5.64 mmol, 74% o2s) as a clear pale yellow oil.

The analytical data are consistent with those reported in the literature.<sup>[185]</sup>

**<sup>1</sup>H-NMR** (400 MHz, CDCl<sub>3</sub>, CHCl<sub>3</sub> = 7.26 ppm):  $\delta$  4.56 – 4.50 (m, 1H, H-4), 1.79 (d,  $J$  = 2.9 Hz, 3H, Me), 1.63 – 1.56 (m, 3H, Me), 1.55 – 1.45 (m, 6H, SnBu<sub>3</sub>), 1.36 – 1.27 (m, 6H, SnBu<sub>3</sub>), 0.94 – 0.88 (m, 15H, SnBu<sub>3</sub>) ppm;

$[\alpha]_{\text{D}}^{22} = -54.8$  ( $c$  = 1.2, CHCl<sub>3</sub>; lit.  $[\alpha]_{\text{D}}^{20} = -50.0$ ,  $c$  = 1.3, CHCl<sub>3</sub>)<sup>[185]</sup>.

<sup>8</sup> CuBr·SMe<sub>2</sub> of highest available purity should be used and must be stored in a glovebox.

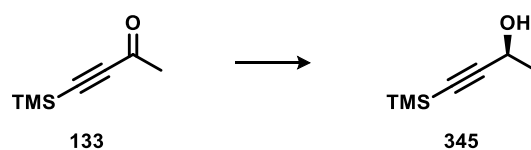
**(S)-4-(Trimethylsilyl)but-3-yn-2-ol (345)**

Commercially available 4-(trimethylsilyl)-3-butyn-2-one **133** (290 mg, 2.07 mmol, 1.0 eq.) was dissolved *i*-PrOH (150 mL) and (*S,S*)-Noyori catalyst (**338**, 40 mg, 0.062 mmol, 3 mol%) in 1 mL CH<sub>2</sub>Cl<sub>2</sub> was added. The dark orange solution was stirred for 18 h at room temperature. Excess of the solvent was removed on a rotovap (70 mbar, 40 °C) and residual solvent was removed by distillation (30 mbar, 80 °C) applying a Vigreux column. The crude product was then purified by distillation (17 mbar, 100 °C) to furnish (*S*)-4-(trimethylsilyl)but-3-yn-2-ol (**345**, 226 mg, 1.59 mmol, 77%) as a colorless oil.

The analytical data are consistent with those reported in the literature.<sup>[186]</sup>

**R<sub>f</sub>** = 0.4 (PE/EtOAc = 5:1);

**<sup>1</sup>H-NMR** (400 MHz, CDCl<sub>3</sub>, CHCl<sub>3</sub> = 7.26 ppm): δ 4.54 – 4.48 (m, 1H, OH), 1.96 (d, *J* = 5.0 Hz, 1H, H-2), 1.44 (d, *J* = 6.6 Hz, 3H, Me), 0.16 (s, 9H, TMS) ppm;

[α]<sub>D</sub><sup>25</sup> = +18.3 (*c* = 2.6, CHCl<sub>3</sub>; lit. [α]<sub>D</sub><sup>20</sup> = +28.3, *c* = 2.3, CHCl<sub>3</sub>)<sup>[187]</sup>;

**b.p.** (17 mbar): 69 – 70 °C (lit. 73 °C, 17 mbar)<sup>[186]</sup>.

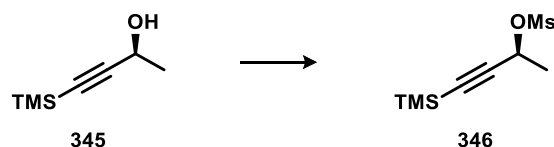
**(S)-4-(Trimethylsilyl)but-3-yn-2-yl methanesulfonate (346)**

To a solution of (*S*)-4-(trimethylsilyl)but-3-yn-2-ol (**345**, 310 mg, 2.18 mmol, 1.0 eq.) and freshly distilled Et<sub>3</sub>N (600 μL, 4.36 mmol, 2.0 eq.) in CH<sub>2</sub>Cl<sub>2</sub> (5 mL), MsCl (254 μL, 3.27 mmol, 1.5 eq.) was added slowly at –78 °C. After stirring for 1 h the reaction was terminated by the addition of a saturated aqueous NaHCO<sub>3</sub> solution. The mixture was allowed to reach room temperature and the phases were separated. The aqueous phase was extracted with Et<sub>2</sub>O (3 x 25 mL) and the combined organic phases were dried over MgSO<sub>4</sub>, filtered and concentrated under reduced pressure. The configuratively instable mesylate **346** was obtained as a clear colorless oil and was directly used in the next step without further purification.

**<sup>1</sup>H-NMR** (400 MHz, CDCl<sub>3</sub>, CHCl<sub>3</sub> = 7.26 ppm): δ 5.25 (q, *J* = 6.7 Hz, 1H, H-2), 3.11 (s, 3H, Ms), 1.62 (d, *J* = 6.7 Hz, 3H, Me), 0.18 (s, 9H, TMS) ppm.

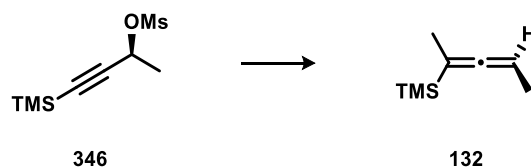

**(R)-Trimethyl(penta-2,3-dien-2-yl)silane (132)**

According to the procedure published by Danheiser *et al.*<sup>[188]</sup> CuBr·SMe<sub>2</sub> (112 mg, 0.545 mmol, 1.2 eq.) and LiBr (47 mg, 0.545 mmol, 1.2 eq.) were suspended in THF (1 mL) and cooled to 0 °C. To this suspension MeMgCl (3.0 M in THF, 363 μL, 1.09 mmol, 2.4 eq.) was added dropwise and stirring was continued for 20 min. The yellow paste was then cooled to -78 °C and mesylate **346** (100 mg, 0.454 mmol, 1.0 eq.) as a solution in THF (1 mL) was added slowly. The mixture was stirred at this temperature for 40 min and was allowed to reach room temperature and stirred for 10 min. The reaction was diluted with *n*-pentane (10 mL) and terminated by the addition of a saturated aqueous NH<sub>4</sub>Cl solution. The phases were separated and the aqueous phase was extracted with *n*-pentane (3 x 10 mL). The combined organic phases were dried over MgSO<sub>4</sub>, filtered and the solvent was removed by fractional distillation. The crude product was purified by flash column chromatography (*n*-pentane) and the solvent was removed by fractional distillation to yield allenylsilane **132** (27 mg, 0.195 mmol, 43% o2s) as a colorless oil.

The analytical data are consistent with those reported in the literature.<sup>[189]</sup>

$R_f = 0.6$  (PE);

<sup>1</sup>H-NMR (400 MHz, CDCl<sub>3</sub>, CHCl<sub>3</sub> = 7.26 ppm): δ 4.59 (qq, *J* = 2.9, 6.8 Hz, 1H, H-4), 1.59 (d, *J* = 2.8 Hz, 3H, Me), 1.43 (d, *J* = 6.8 Hz, 3H, Me), 0.05 (s, 9H, TMS) ppm;

$[\alpha]_D^{23} = -59.2$  (*c* = 1.0, CHCl<sub>3</sub>).

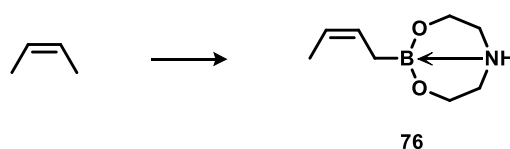
**(Z)-Crotylboronate Diethanolamine Complex (76)**

According to the procedure published by Roush *et al.*<sup>[89]</sup> KO<sup>t</sup>-Bu (2.0 g, 18.04 mmol, 1.1 eq.) was suspended THF (15 mL) and cooled to -78 °C. *cis*-Butene (1.4 mL, 16.40 mmol, 1.0 eq.) was condensed in a small vial and transferred to the reaction flask via cannula, followed by slow addition of *n*-BuLi (2.5 M in hexane, 5.25 mL, 13.12 mmol, 0.8 eq.). The resulting mixture was stirred for 1 h and was then warmed to -25 °C and stirred at this temperature for 45 min. The mixture was again cooled to -78 °C and triisopropyl borate (3.1 mL, 13.12 mmol, 0.8 eq.) was added dropwise and stirring was continued for 30 min. The reaction was terminated by the addition of an aqueous 1 M HCl solution (5 mL) and was stirred vigorously. While the mixture was allowed to reach room temperature additional 1 M HCl solution (35 mL) was added. The phases were separated and the aqueous phase was extracted

with EtOAc (3 x 20 mL). The combined organic phases were collected in a flask under argon and molecular sieves (4 Å, powder, 0.6 g) and diethanolamine (1.1 mL, 11.48 mmol, 0.7 eq.) were added. The mixture was stirred for 2 h at room temperature before it was filtered and rinsed with EtOAc. The solvent was removed under reduced pressure and the crude product was recrystallized from CH<sub>2</sub>Cl<sub>2</sub> and Et<sub>2</sub>O to yield (*Z*)-crotylboronate diethanolamine complex **76** (1.83 g, 10.82 mmol, 66%) as colorless crystals. The material was stored under argon at -20 °C.

**m.p.** 120–122 °C (lit. 121–123 °C)<sup>[190]</sup>.

### (*S,S*)-Diisopropyl (*Z*)-Crotylboronate (**74**)

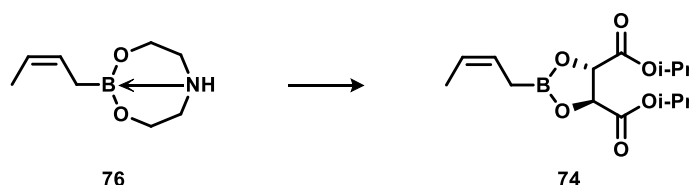

To a rapidly stirred suspension of the (*Z*)-crotylboronate diethanolamine complex **76** (101 mg, 0.598 mmol, 1.0 eq.) in Et<sub>2</sub>O (2 mL) (*S,S*)-diisopropyl tartrate (126 μL, 0.598 mmol, 1.0 eq.) was added and stirring was continued for 5 min. Brine (1.5 mL) was added and stirring was continued for 5 min. The phases were separated and the aqueous phase was extracted with Et<sub>2</sub>O (3 x 5 mL). The combined organic phases were dried over MgSO<sub>4</sub>, filtered and the solvent was removed under reduced pressure to yield (*S,S*)-diisopropyl (*Z*)-crotylboronate (**74**, 162 mg, 0.543 mmol, 91%) as a colorless oil which was used immediately in the next step without further analysis.

### 1-Chloro-*N,N*-diethyl-1,1-diphenylsilanamine (**83**)

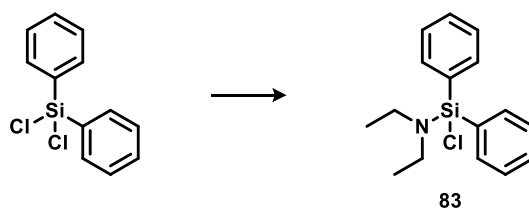

According to the procedure published by Tamao *et al.*<sup>[191]</sup> dichlorodiphenylsilane (2.0 mL, 9.59 mmol, 1.0 eq.) was dissolved in THF (12 mL) at room temperature and Et<sub>3</sub>N (1.6 mL, 11.51 mmol, 1.2 eq.) was added. A solution of Et<sub>2</sub>NH (1.2 mL, 11.51 mmol, 1.2 eq.) in THF (1 mL) was slowly added to the reaction. During the addition, a large amount of colorless Et<sub>3</sub>N·HCl salt precipitated. After the addition was complete, the reaction was stirred for 5 h at room temperature, before the mixture was diluted with PE (20 mL) and filtered through a glass frit. The solvent was removed under reduced pressure and the crude product was purified by distillation applying a micro-distillation apparatus and a metal bath to give a pale yellow oil which was then further purified by Kugelrohr distillation (1.5 mbar, 154 °C) to yield silicon tether **83** (1.58 g, 5.45 mmol, 57%) as a colorless oil.

The analytical data are consistent with those reported in the literature.<sup>[191,192]</sup>

**<sup>1</sup>H-NMR** (400 MHz, CDCl<sub>3</sub>, CHCl<sub>3</sub> = 7.26 ppm): δ 7.78 – 7.76 (m, 5H, H<sub>Ar</sub>), 7.54 – 7.39 (m, 5H, H<sub>Ar</sub>), 2.59 (q, *J* = 7.0 Hz, 4H, CH<sub>2</sub>), 1.06 (t, *J* = 7.0 Hz, 6H, Me) ppm;

**<sup>13</sup>C-NMR** (400 MHz, CDCl<sub>3</sub>, CDCl<sub>3</sub> = 77.16 ppm): δ 135.1 (d, 2C, C<sub>Ar</sub>), 134.2 (d, 2C, C<sub>Ar</sub>), 133.7 (s, 2C, C<sub>Ar</sub>), 130.5 (d, 2C, C<sub>Ar</sub>), 128.5 (d, 2C, C<sub>Ar</sub>), 128.1 (d, 2C, C<sub>Ar</sub>), 39.4 (t, 2C, CH<sub>2</sub>), 14.7 (q, 2C, Me) ppm<sup>[192]</sup>;

**b.p.** (5.0 mbar) = 163 – 165 °C (lit. 129 – 133 °C, 0.55 mmHg)<sup>[191]</sup>;

**HRMS-EI** *m/z* (%) 217.0301 [M-N(CH<sub>2</sub>CH<sub>3</sub>)<sub>2</sub>]<sup>+</sup> (83%; <sup>35</sup>Cl), 219.0291 [M-N(CH<sub>2</sub>CH<sub>3</sub>)<sub>2</sub>]<sup>+</sup> (11%; <sup>37</sup>Cl), 274.0929 [M-CH<sub>3</sub>]<sup>+</sup> (100%; <sup>35</sup>Cl), 276.0962 [M-CH<sub>3</sub>]<sup>+</sup> (10%; <sup>37</sup>Cl).

#### 4-Methoxybenzyl-2,2,2-trichloroacetimidate (**48**)

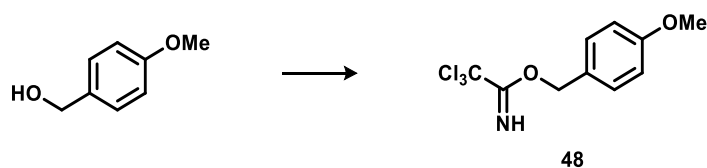

Sodium hydride (60% dispersion in mineral oil, 0.64 g, 16.0 mmol, 0.1 eq.) was suspended in Et<sub>2</sub>O (50 mL). 4-Methoxybenzyl alcohol (20.0 mL, 160.0 mmol, 1.0 eq.) was added slowly and the resulting mixture was stirred for 30 min at room temperature. The mixture was then cooled to 0 °C and trichloroacetonitrile (17.7 mL, 176.0 mmol, 1.1 eq.) was added dropwise via syringe pump over 15 min and stirring was continued for 1 h at this temperature. The reaction was then allowed to reach room temperature and stirred for further 40 min before it was concentrated under reduced pressure to give a brown oil. The crude product was treated with a mixture of pentane and MeOH (170 mL, 275:1) and stirred for 30 min. The heterogeneous mixture containing a dark, highly viscous residue was filtered through a plug of Celite<sup>®</sup> and the filtrate was concentrated under reduced pressure to yield 4-methoxybenzyl-2,2,2-trichloroacetimidate (**48**, 42.09 g, 149.0 mmol, 93%) as a dark orange oil.

The analytical data are consistent with those reported in the literature.<sup>[193]</sup>

**<sup>1</sup>H-NMR** (400 MHz, CDCl<sub>3</sub>, CHCl<sub>3</sub> = 7.26 ppm): δ 8.36 (s, 1H, NH), 7.37 (d, *J* = 8.5 Hz, 2H, H<sub>Ar</sub>), 6.91 (d, *J* = 8.6 Hz, 2H, H<sub>Ar</sub>), 5.27 (s, 2H, CH<sub>2</sub>), 3.82 (s, 3H, OMe).

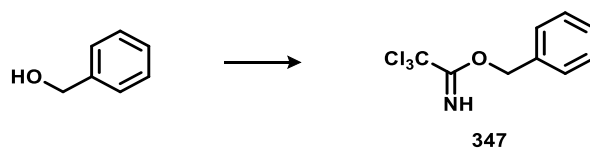
**Benzyl-2,2,2-trichloroacetimidate (347)**

Following the procedure described above, benzyl-2,2,2-trichloroacetimidate (**347**, 35.02 g, 139.79 mmol, 91%) was obtained as a pale-yellow oil.

The analytical data are consistent with those reported in the literature.<sup>[194]</sup>

**<sup>1</sup>H-NMR** (400 MHz, CDCl<sub>3</sub>, CHCl<sub>3</sub> = 7.26 ppm):  $\delta$  8.34 (s, 1H, NH), 7.40 – 7.27 (m, 5H, H<sub>Ar</sub>), 5.29 (s, 2H, CH<sub>2</sub>).

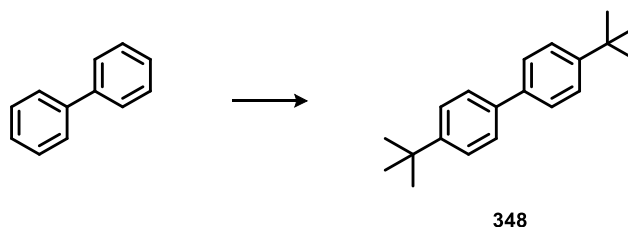
**4,4'-Di-*tert*-butylbiphenyl (348)**

Biphenyl (15.4 g, 100.0 mmol, 1.0 eq.) and *t*-BuCl (23.2 mL, 220.0 mmol, 2.2 eq.) were dissolved in CH<sub>2</sub>Cl<sub>2</sub> (100 mL). To this solution a suspension of anhydrous FeCl<sub>3</sub> (81 mg, 0.50 mmol, 5.0 mol%) in CH<sub>2</sub>Cl<sub>2</sub> (5 mL) was added slowly. After the gas evolution subsided, the green mixture was warmed to 40 °C and stirred for 15 min. The reaction was terminated by the addition of a MeOH (10 mL) and washed with water (250 mL) and saturated aqueous NaHCO<sub>3</sub> solution (100 mL). The organic phase was dried over MgSO<sub>4</sub>, filtered and the solvent was removed under reduced pressure. The crude product was recrystallized from EtOH furnishing 4,4'-di-*tert*-butylbiphenyl (**348**, 23.05 g, 0.816 mmol, 82%) as colorless crystals.

The analytical data are consistent with those reported in the literature.<sup>[195]</sup>

**<sup>1</sup>H-NMR** (400 MHz, CDCl<sub>3</sub>, CHCl<sub>3</sub> = 7.26 ppm):  $\delta$  7.53 (d,  $J$  = 8.6 Hz, 4H, H<sub>Ar</sub>), 7.45 (d,  $J$  = 8.6 Hz, 4H, H<sub>Ar</sub>), 1.36 (s, 18H, *t*-Bu) ppm;

**m.p.** 126–128 °C (lit. 127–128 °C)<sup>[195]</sup>.

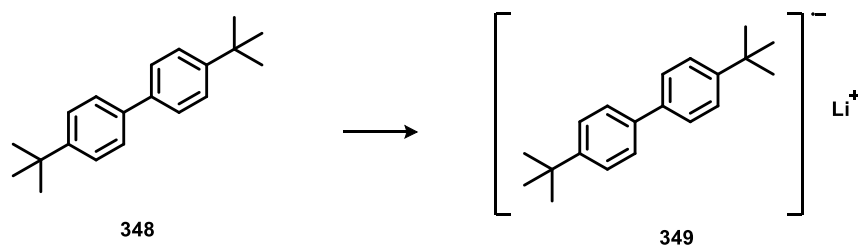
**Lithium 4,4'-di-*tert*-butylbiphenylide (LiDBB, 349)**

According to the procedure published by Rychnovsky and Hill<sup>[155]</sup> 4,4'-di-*tert*-butylbiphenyl (**348**, 500 mg, 1.88 mmol, 1.0 eq.) was added to a flask, followed by evacuating and flame-drying. Once the DBB was melted, the flask was backfilled with argon and allowed to cool to room temperature. THF (14 mL) was added and the flask was then cooled to 0 °C. Lithium wire (130 mg, 18.8 mmol 10.0 eq.) was plucked into small pieces under an argon stream to increase the unoxidised surface area of the metal and added to the flask. The resulting green mixture was stirred at 0 °C for 5 h darkening in color. The concentration of the LiDBB solution (0.35–0.4 M) was determined by titration with a calibrated menthol solution in THF at 0 °C. The solution was stored under argon at –30 °C.<sup>9</sup>

**Samarium(II) iodide (339)**

SmI<sub>2</sub> was prepared following the procedure for the preparation from “inactive” samarium metal<sup>10</sup>, as published by Procter *et al.*<sup>[172]</sup>

A 50 mL Schlenk finger equipped with a magnetic stirring bar was flame-dried. After cooling to room temperature the atmosphere was changed by evacuating and backfilling with argon (3x). “Inactive” samarium metal (825 mg, 5.50 mmol, 1.0 eq.) was added and the atmosphere was changed (3x) as described above. The Schlenk finger was left under a positive pressure of argon while “dry”-stirring for 24 h. After that time freshly distilled THF (22.5 mL) was added, followed by a solution of iodine (700 mg, 2.75 mmol, 0.5 eq.) in THF (5 mL). The mixture was heated to 60 °C and stirring was continued for 18 h. The resulting deep-blue SmI<sub>2</sub> suspension (~ 0.1 M) was allowed to settle for 1 h before it was used. The suspension was stored under argon with stirring on the bench top.

<sup>9</sup> After 3 weeks of storage, the molarity of the solution decreased and the solution was remade.

<sup>10</sup> Inactive samarium is samarium metal with an oxide coating on the metal surface.

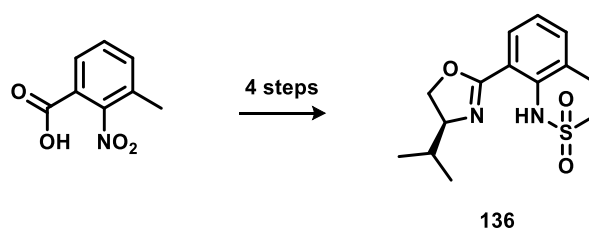
**(S)-N-(2-(4-Isopropyl-4,5-dihydrooxazol-2-yl)-6-methylphenyl)methanesulfonamide (136)**

Following the procedure published by Kishi *et al.*<sup>[112]</sup> 3-methyl-2-nitrobenzoic acid (3.0 g, 16.56 mmol, 1.0 eq.) was dissolved in CH<sub>2</sub>Cl<sub>2</sub> (30 mL) and was treated with DMF (120 μL) and oxalyl chloride (2.40 mL, 27.50 mmol, 1.7 eq.) at 0 °C. The suspension was stirred at this temperature for 4.5 h. The resulting clear solution was stirred at room temperature overnight. The solvent was removed under reduced pressure to give the crude acid chloride as a yellow solid, which was used in the next step without further purification.

The crude acid chloride was dissolved in CH<sub>2</sub>Cl<sub>2</sub> (30 mL) and was treated with (*L*)-valinol (1.71 g, 16.56 mmol, 1.0 eq.) at 0 °C, followed by Et<sub>3</sub>N (5.1 mL, 36.43 mmol, 2.2 eq.). The reaction mixture was stirred at this temperature for 30 min and at room temperature for 6 h. The reaction was terminated by the addition of a saturated aqueous NH<sub>4</sub>Cl solution and diluted with CH<sub>2</sub>Cl<sub>2</sub>. The phases were separated and the aqueous phase was extracted with CH<sub>2</sub>Cl<sub>2</sub> (3 x 15 mL). The combined organic phases were washed with brine, dried over Na<sub>2</sub>SO<sub>4</sub>, filtered and the solvent was removed under reduced pressure to yield the crude amide as a colorless solid.

The crude amide was dissolved in MeOH (20 mL) and THF (8 mL) and was treated with 10% Pd/C (50 mg, 0.050 mmol, 0.3 mol%). The atmosphere was changed by evacuating and backfilling with H<sub>2</sub> (3x) and stirring was continued under H<sub>2</sub> atmosphere (balloon) at room temperature for 48 h. The flask was purged with argon and the reaction mixture was filtered over Celite<sup>®</sup> and the solvent was removed under reduced pressure to yield the resulting amine as a colorless oil.

The crude amine was dissolved in pyridine (35 mL) and was treated with DMAP (40.46 mg, 3.31 mmol, 0.02 eq.) and MsCl (3.9 mL, 49.68 mmol, 3.0 eq.) at 0 °C. The reaction mixture was stirred at 0 °C for 1 h, then at room temperature for 8 h. The solvent was removed under reduced pressure and the resulting residue was dissolved in EtOAc and saturated aqueous NH<sub>4</sub>Cl solution was added. The phases were separated and the aqueous phase was extracted with EtOAc (3 x 20 mL). The combined organic phases were washed with brine, dried over Na<sub>2</sub>SO<sub>4</sub>, filtered and the solvent was removed under reduced pressure. The crude product was purified by flash column chromatography (2% MeOH/CH<sub>2</sub>Cl<sub>2</sub>). Recrystallization from Et<sub>2</sub>O and PE furnished methanesulfonamide **136** (3.09 g, 10.43 mmol, 63% over 4 steps) as a colorless solid.

The analytical data are consistent with those reported in the literature.<sup>[112]</sup>

**R<sub>f</sub>** = 0.3 (PE/EtOAc = 5:1);

**<sup>1</sup>H-NMR** (400 MHz, CDCl<sub>3</sub>, CHCl<sub>3</sub> = 7.26 ppm): δ 10.47 (bs, 1H, NH), 7.73 (d, *J* = 7.6 Hz, 1H, H<sub>Ar</sub>), 7.42 (d, *J* = 7.4 Hz, 1H, H<sub>Ar</sub>), 7.20 (t, *J* = 7.7 Hz, 1H, H<sub>Ar</sub>), 4.49 – 4.42 (m, 1H,

HCN), 4.15 – 4.08 (m, 2H, H<sub>2</sub>CO), 2.83 (s, 3H, Me), 2.56 (s, 3H, Me), 1.81 – 1.80 (m, 1H, H<sub>i-Pr</sub>), 1.10 (d,  $J = 6.6$  Hz, 3H, Me<sub>*i-Pr*</sub>), 0.95 (d,  $J = 6.7$  Hz, 3H, Me<sub>*i-Pr*</sub>) ppm;  
 $[\alpha]_D^{24} = -6.0$  ( $c = 1.0$ , MeOH; lit.  $[\alpha]_D^{20} = -5.8$ ,  $c = 1.0$ , MeOH)<sup>[112]</sup>;  
**m.p.** 81–83 °C (lit. 82–83 °C)<sup>[112]</sup>;  
**HRMS-ESI**  $m/z$  for C<sub>14</sub>H<sub>21</sub>N<sub>2</sub>O<sub>3</sub>S [M+H]<sup>+</sup> calc. 297.1272, found 297.1269.

***N*-((1*R*,2*R*)-1-Hydroxy-1-phenylpropan-2-yl)-2-methoxy-*N*-methylacetamide (Myers auxiliary, 65)**

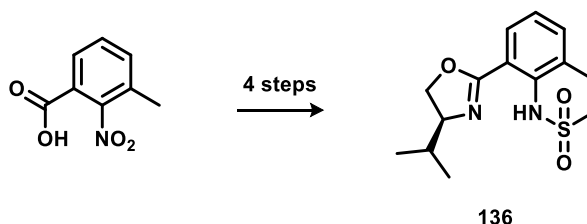

LiCl (0.78 g, 18.16 mmol, 3.0 eq.) and (–)-pseudoephedrine (1.0 g, 6.05 mmol, 1.0 eq.) were suspended in THF (50 mL) and cooled to 0 °C. *n*-BuLi (2.5 M in hexanes, 1.21 mL, 3.03 mmol 0.5 eq.) was added slowly and stirring was continued at this temperature for 20 min. Methyl methoxyacetate (1.20 mL, 12.10 mmol, 2.0 eq.) was then added and the mixture was allowed to reach room temperature and was stirred for 2 h. An aqueous 0.5 M NaOH solution was added and the biphasic mixture was stirred for 1 h. All volatiles were removed under reduced pressure and the aqueous residue was extracted with MeOH/CH<sub>2</sub>Cl<sub>2</sub> (10%, 4 x 20 mL). The combined organic phases were dried over MgSO<sub>4</sub>, filtered and the solvent was removed under reduced pressure. The crude product was purified by flash column chromatography (8% MeOH/CH<sub>2</sub>Cl<sub>2</sub>) furnishing amide **62** (1.39 g, 5.87 mmol, 97%, 1.3:1 mixture of rotamers<sup>11</sup>) as a colorless oil which slowly solidified.

The analytical data are consistent with those reported in the literature.<sup>[101]</sup>

**R<sub>f</sub>** = 0.5 (8% MeOH/CH<sub>2</sub>Cl<sub>2</sub>);

**<sup>1</sup>H-NMR** (400 MHz, CDCl<sub>3</sub>, CHCl<sub>3</sub> = 7.26 ppm): δ 7.39 – 7.26 (m, 10H, H<sub>Ar</sub>, H<sub>Ar</sub><sup>R</sup>), 4.62 (d,  $J = 7.8$  Hz, 1H, H-2), 4.51 (d,  $J = 9.1$  Hz, 1H, H-2<sup>R</sup>), 4.44 – 4.40 (m, 1H, H-1), 4.23 – 4.16 (m, 2H, CH<sub>2</sub><sup>R</sup>), 4.09 – 4.02 (m, 2H, CH<sub>2</sub>), 3.99 – 3.96 (m, 1H, H-1<sup>R</sup>), 3.47 (s, 3H, OMe<sup>R</sup>), 3.38 (s, 3H, OMe), 2.94 (s, 3H, NMe<sup>R</sup>), 2.79 (s, 3H, NMe), 1.13 (d,  $J = 7.0$  Hz, 3H, Me), 0.99 (d,  $J = 6.7$  Hz, 3H, Me<sup>R</sup>) ppm;

$[\alpha]_D^{23} = -104.1$  ( $c = 1.3$ , CH<sub>2</sub>Cl<sub>2</sub>; lit.  $[\alpha]_D^{20} = -98.7$ ,  $c = 1.5$ , CHCl<sub>3</sub>)<sup>[101]</sup>;

**m.p.** 75–77 °C;

**HRMS-ESI**  $m/z$  for C<sub>13</sub>H<sub>19</sub>NO<sub>3</sub>Na [M+Na]<sup>+</sup> calc. 260.1263, found 260.1264.

<sup>11</sup> Superscript “R” in the NMR signal assignment indicates rotamer.

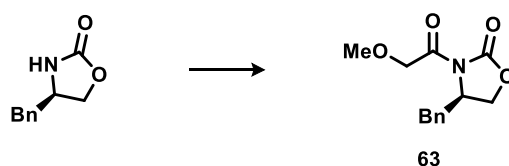
**(R)-4-Benzyl-3-(2-methoxyacetyl)oxazolidin-2-one (63)**

(R)-4-Benzyloxazolidin-2-one (3.96 g, 22.35 mmol, 1.0 eq.) was dissolved in THF (20 mL) and cooled to  $-78\text{ }^{\circ}\text{C}$ . *n*-BuLi (2.5 M in hexane, 9.80 mL, 24.59 mmol, 1.1 eq.) was added via syringe pump over 15 min. The mixture was stirred for 30 min at this temperature before methoxyacetyl chloride (2.30 mL, 24.59 mmol, 1.1 eq.) diluted in THF (8 mL) was added via syringe pump over 15 min. The mixture was stirred for 30 min at  $-78\text{ }^{\circ}\text{C}$  and 30 min at  $0\text{ }^{\circ}\text{C}$ . The reaction was terminated by the addition of a saturated aqueous  $\text{NH}_4\text{Cl}$  solution. The phases were separated and the aqueous phase was extracted with EtOAc (3 x 20 mL). The combined organic phases were dried over  $\text{MgSO}_4$ , filtered and the solvent was removed under reduced pressure. The crude product was purified by flash column chromatography (PE/EtOAc = 4:1  $\rightarrow$  1:1) to yield (R)-4-benzyl-3-(2-methoxyacetyl)oxazolidin-2-one (**63**, 4.98 g, 19.99 mmol, 89%) as a colorless oil.

The analytical data are consistent with those reported in the literature.<sup>[196]</sup>

$R_f = 0.5$  (PE/EtOAc = 1:1);

$^1\text{H-NMR}$  (400 MHz,  $\text{CDCl}_3$ ,  $\text{CHCl}_3 = 7.26$  ppm):  $\delta$  7.36 – 7.20 (m, 5H, Bn), 4.73 – 4.67 (m, 1H, H-4), 4.62 (d,  $J = 4.1$  Hz, 2H, H-5), 4.32 – 4.22 (m, 2H,  $\text{CH}_2\text{OMe}$ ), 3.52 (s, 3H, OMe), 3.33 (dd,  $J = 13.4, 3.3$  Hz, 1H,  $\text{CH}_2\text{Ph}$ ), 2.83 (dd,  $J = 13.4, 9.4$  Hz, 1H, Bn) ppm;

$[\alpha]_D^{21} = -74.6$  ( $c = 1.1$ ,  $\text{CH}_2\text{Cl}_2$ ; lit.  $[\alpha]_D^{20} = -76.5$ ,  $c = 1.5$ ,  $\text{CH}_2\text{Cl}_2$ )<sup>[196]</sup>.

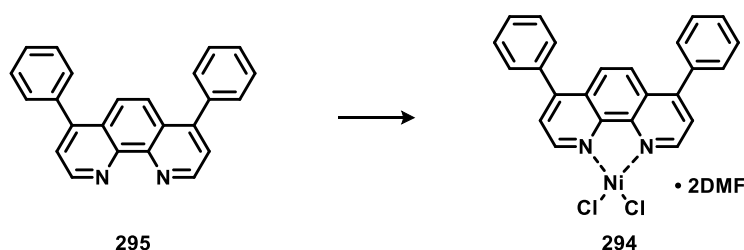
**Ni(BPhen)Cl<sub>2</sub>·2DMF complex (294)**

According to the procedure published by Baran *et al.*<sup>[179]</sup>  $\text{NiCl}_2 \cdot 6\text{H}_2\text{O}$  (143 mg, 0.607 mmol, 1.0 eq.) and bathophenanthroline (**295**, 200 mg, 0.607 mmol, 1.0 eq.) were suspended in DMF (3 mL) and stirred at  $70\text{ }^{\circ}\text{C}$  for 8 h. The hot mixture was then filtered through a glass frit and washed with PE (10 mL). The remaining solid was left to dry in the hood for 15 min and was then dried overnight under high vacuum to yield  $\text{Ni}(\text{BPhen})\text{Cl}_2 \cdot 2\text{DMF}$  (**294**, 200 mg, 0.433 mmol, 72%) as a green solid. The complex was stored and handled on the bench top and was used without further purification or analysis.

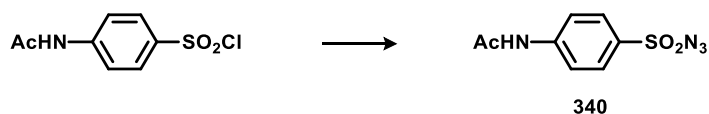

**4-Acetamidobenzenesulfonyl azide (340)**

4-Acetamidobenzenesulfonyl chloride (4.19 g, 17.97 mmol, 1.0 eq.) was suspended in  $\text{CH}_2\text{Cl}_2$  (30 mL) and TBAC (12.5 mg, 44.93  $\mu\text{mol}$ , 0.25 mol%) was added. A solution of  $\text{NaN}_3$  (1.75 g, 26.96 mmol, 1.5 eq.) in water (8 mL) was carefully added and the mixture was stirred at room temperature overnight. The two now clear phases were separated and the organic phase was washed with water (2 x 5 mL), dried over  $\text{MgSO}_4$  and filtered. The solvent was removed under reduced pressure to yield azide **340** (3.88 g, 16.17 mmol, 90%) as a colorless solid which was directly used in the next step (see p. 100).

**$^1\text{H-NMR}$**  (400 MHz,  $\text{CDCl}_3$ ,  $\text{CHCl}_3 = 7.26$  ppm):  $\delta$  8.00 (bs, 1H, NH), 7.89 (d,  $J = 8.9$  Hz, 2H,  $\text{H}_{\text{Ar}}$ ), 7.77 (d,  $J = 8.9$  Hz, 2H,  $\text{H}_{\text{Ar}}$ ), 2.25 (s, 3H, Me) ppm.

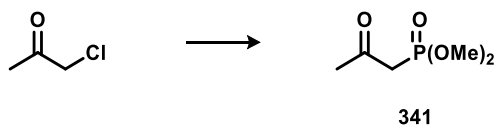
**Dimethyl (2-oxopropyl)phosphonate (341)**

Potassium iodide (4.95 g, 29.80 mmol, 1.0 eq.) was suspended in MeCN/acetone (5:4, 13.5 mL) at room temperature and chloroacetone (2.4 mL, 29.80 mmol, 1.0 eq.) was added. The mixture was stirred for 1 h in the absence of light before trimethyl phosphite (3.5 mL, 29.8 mmol, 1.0 eq.) was added dropwise and stirring was continued for 12 h. The mixture was then heated to 50  $^\circ\text{C}$  and stirred for 1 h to ensure complete conversion. After cooling to room temperature, the mixture was filtered through a pad of Celite<sup>®</sup> and the solvent was removed under reduced pressure. The crude product was purified by distillation to yield phosphonate **341** (2.92 g, 17.58 mmol, 59%) as a colorless oil.

The analytical data are consistent with those reported in the literature.<sup>[197]</sup>

**$^1\text{H-NMR}$**  (400 MHz,  $\text{CDCl}_3$ ,  $\text{CHCl}_3 = 7.26$  ppm):  $\delta$  3.78 (d,  $J = 11.0$  Hz, 6H,  $\text{P}(\text{OMe})_2$ ), 3.08 (d,  $J = 22.8$  Hz, 2H,  $\text{CH}_2$ ), 2.31 (s, 3H, Me) ppm;

**b.p.** (1.0 mbar) = 80–82  $^\circ\text{C}$  (lit. 69–70  $^\circ\text{C}$ , 0.47 mbar)<sup>[197]</sup>.

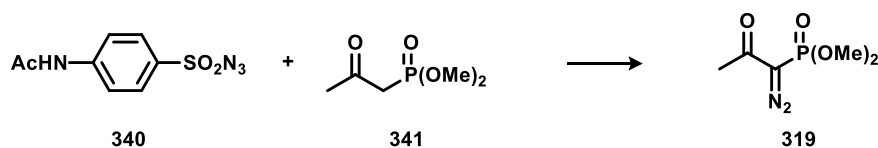
**Dimethyl (1-diazo-2-oxopropyl)phosphonate (Ohira-Bestmann Reagent, 319)**

Phosphonate **341** (2.90 g, 17.46 mmol, 1.08 eq.) was dissolved in PhMe (20 mL) and was cooled to 0 °C. Sodium hydride (60% dispersion in mineral oil, 0.647 g, 16.17 mmol, 1.0 eq.) was added in portions. After the gas evolution has stopped, a solution of azide **340** (3.88 g, 16.17 mmol, 1.0 eq.) in THF (7 ml) was added dropwise. Stirring was continued and the reaction was allowed to reach room temperature overnight. The mixture was diluted with PE (20 mL), filtered through a plug of Celite<sup>®</sup> and thoroughly rinsed with Et<sub>2</sub>O. The solvent was removed under reduced pressure. The crude product was purified by flash column chromatography (PE/EtOAc = 1:1) to yield diazophosphonate **319** (2.48 g, 12.94 mmol, 80%) as a pale yellow oil.

The analytical data are consistent with those reported in the literature.<sup>[197]</sup>

<sup>1</sup>H-NMR (400 MHz, CDCl<sub>3</sub>, CHCl<sub>3</sub> = 7.26 ppm): δ 3.84 (d, *J* = 11.9 Hz, 6H, P(OMe)<sub>2</sub>), 2.26 (s, 3H, Me) ppm.

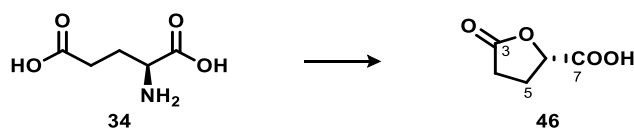
**5.3 First Generation Synthesis****5.3.1 Eastern Fragment****(S)-5-Oxotetrahydrofuran-2-carboxylic acid (46)**

L-Glutamic acid (**34**, 29.4 g, 0.20 mol, 1.0 eq.) was dissolved in water (200 mL) and aqueous HCl (2 M, 120 mL) was added. The mixture was stirred and cooled to 0 °C controlling the inner temperature with a thermometer. A solution of NaNO<sub>2</sub> (16.8 g, 0.24 mol, 1.2 eq.) in water (120 mL) was added dropwise through a dropping funnel maintaining the temperature at 0 °C. After the addition was finished, the reaction was allowed to reach room temperature and was stirred for 18 h. The solvent was removed under reduced pressure and the colorless sluggish residue was dissolved in EtOAc (200 mL) and anhydrous Na<sub>2</sub>SO<sub>4</sub> was added. Stirring was continued for 2 h. The mixture was filtered and the solvent was removed under reduced pressure to give a colorless oil which was dissolved in Et<sub>2</sub>O (60 mL). Crystallization was induced upon storage at -30 °C for 2 days to afford acid **46** (12.10 g, 93.0 mmol, 47%) as colorless crystals.

The analytical data are consistent with those reported in the literature.<sup>[198]</sup>

<sup>1</sup>H-NMR (400 MHz, MeOD-d<sub>4</sub>, MeOH = 3.31 ppm): δ 5.01 – 4.98 (m, 1H, H-6), 2.65 – 2.53 (m, 3H, H-4, H-5), 2.35 – 2.26 (m, 1H, H-5') ppm;

**<sup>1</sup>H-NMR** (400 MHz, DMSO-*d*<sub>6</sub>, DMSO = 2.50 ppm):  $\delta$  13.26 (s, 1H, COOH), 4.98 – 4.95 (m, 1H, H-6), 2.53 – 2.44 (m, 3H, H-4, H-5), 2.21 – 2.14 (m, 1H, H-5') ppm;  
**<sup>13</sup>C-NMR** (400 MHz, MeOD-*d*<sub>4</sub>, MeOH = 49.00 ppm):  $\delta$  179.0 (s, C-3), 173.4 (s, COOH), 77.4 (d, C-6), 27.8 (t, C-4), 26.9 (t, C-5) ppm;  
 $[\alpha]_{\text{D}}^{20} = +12.3$  ( $c = 1.0$ , EtOH; lit.  $[\alpha]_{\text{D}}^{20} = +15.6$ ,  $c = 2.4$ , EtOH)<sup>[198]</sup>;  
**m.p.** 71 °C (lit. 71–73 °C)<sup>[198]</sup>;  
**HRMS-ESI**  $m/z$  for C<sub>5</sub>H<sub>4</sub>O<sub>4</sub> [M-H]<sup>-</sup> calc. 129.0188, found 129.0187.

**(S)-5-(Hydroxymethyl)dihydrofuran-2(3H)-one (47)**

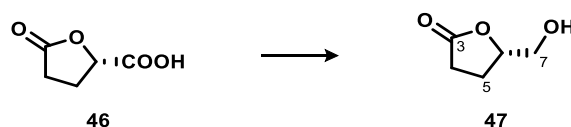

Carboxylic acid **46** (12.10 g, 93.0 mmol, 1.0 eq.) was dissolved in THF (70 mL), cooled to 0 °C and BH<sub>3</sub>·SMe<sub>2</sub> (2 M in THF, 69.8 mL, 139.5 mmol, 1.5 eq.) was added dropwise via syringe pump. The reaction was stirred at this temperature for 1 h before being warmed to room temperature. Stirring was continued for 12 h and the reaction was terminated by careful addition of MeOH (50 mL). Most of the solvent was removed under reduced pressure and the crude product was purified by vacuum distillation (150 °C, 7.0 mbar) to afford alcohol **47** (9.93 g, 85.6 mmol, 92%) as a colorless oil.

The analytical data are consistent with those reported in the literature.<sup>[198]</sup>

**<sup>1</sup>H-NMR** (400 MHz, MeOD-*d*<sub>4</sub>, MeOH = 3.31 ppm):  $\delta$  4.64 – 4.59 (m, 1H, H-6), 3.77 (dd,  $J = 3.1, 12.4$  Hz, 1H, H-7), 3.60 (dd,  $J = 4.5, 12.4$  Hz, 1H, H-7'), 2.58 – 2.54 (m, 2H, H-4), 2.32 – 2.23 (m, 1H, H-5), 2.14 – 2.05 (m, 1H, H-5') ppm;

**<sup>13</sup>C-NMR** (400 MHz, MeOD-*d*<sub>4</sub>, MeOH = 49.0 ppm):  $\delta$  180.4 (s, C-3), 82.8 (d, C-6), 64.5 (t, C-7), 29.5 (t, C-4), 24.2 (t, C-5) ppm;

$[\alpha]_{\text{D}}^{22} = +22.9$  ( $c = 1.4$ , EtOH; lit.  $[\alpha]_{\text{D}}^{20} = +29.6$ ,  $c = 0.4$ , EtOH)<sup>[198]</sup>;

**b.p.** (7.0 mbar) = 147–150 °C (lit. 134–135 °C, 1.3 mbar)<sup>[199]</sup>;

**HRMS**  $m/z$  for C<sub>5</sub>H<sub>8</sub>O<sub>3</sub>Na [M+Na]<sup>+</sup> calc. 139.0371, found 139.0372.

**(S)-5-(((4-Methoxybenzyl)oxy)methyl)dihydrofuran-2(3H)-one (49)**

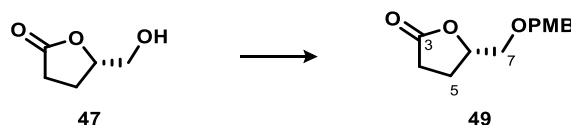

Alcohol **47** (1.66 g, 14.28 mmol, 1.0 eq.) was dissolved in CH<sub>2</sub>Cl<sub>2</sub> (50 mL) at room temperature. 4-Methoxybenzyl-2,2,2-trichloroacetimidate (6.05 g, 21.42 mmol, 1.5 eq.) was added, followed by CSA (165.8 mg, 0.71 mmol, 5 mol%). Stirring was continued for 3 days before the reaction was terminated by the addition of a saturated aqueous NaHCO<sub>3</sub> solution. The phases were separated and the aqueous phase was extracted with CH<sub>2</sub>Cl<sub>2</sub> (3 x 30 mL).

The combined organic phases were dried over  $\text{MgSO}_4$ , filtered and the solvent was removed under reduced pressure. The crude product was purified by flash column chromatography (PE/EtOAc = 6:1  $\rightarrow$  1:1) to furnish protected alcohol **49** (3.09 g, 13.07 mmol, 92%) as an orange oil.

The analytical data are consistent with those reported in the literature.<sup>[200]</sup>

$R_f = 0.2$  (PE/EtOAc = 2:1);

**$^1\text{H-NMR}$**  (400 MHz,  $\text{CDCl}_3$ ,  $\text{CHCl}_3 = 7.26$  ppm):  $\delta$  7.24 (app.<sup>12</sup> d,  $J = 8.8$  Hz, 2H, PMB), 6.88 (app. d,  $J = 8.7$  Hz, 2H, PMB), 4.68 – 4.62 (m, 1H, H-6), 4.49 (dd,  $J = 26.6, 3.4$  Hz, 2H, PMB), 3.80 (s, 3H, PMB), 3.64 (dd,  $J = 10.7, 3.5$  Hz, 1H, H-7), 3.55 (dd,  $J = 10.7, 4.2$  Hz, 1H, H-7'), 2.61 (ddd,  $J = 17.7, 10.0, 6.6$  Hz, 1H, H-4), 2.47 (ddd,  $J = 17.7, 9.9, 7.0$  Hz, 1H, H-4'), 2.27 (dddd,  $J = 12.8, 9.9, 7.8, 6.6$  Hz, 1H, H-5), 2.11 (dddd,  $J = 12.8, 10.0, 7.0, 5.9$  Hz, 1H, H-5') ppm;

$[\alpha]_{\text{D}}^{20} = +6.9$  ( $c = 1.1$ ,  $\text{CH}_2\text{Cl}_2$ ; lit.  $[\alpha]_{\text{D}}^{20} = +10.6$ ,  $c = 1.0$ ,  $\text{CHCl}_3$ )<sup>[200]</sup>;

**HRMS-ESI**  $m/z$  for  $\text{C}_{13}\text{H}_{16}\text{O}_4\text{Na}$   $[\text{M}+\text{Na}]^+$  calc. 259.0947, found 259.0944.

### (S)-5-((4-Methoxybenzyl)oxy)pentane-1,4-diol (**50**)

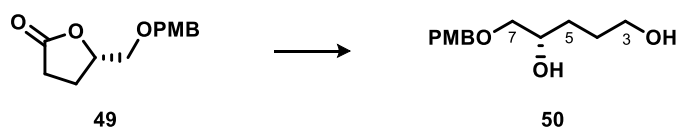

PMB-ether **49** (1.72 g, 7.28 mmol, 1.0 eq.) as a solution in THF (20 mL) was slowly added to a suspension of lithium aluminium hydride (0.69 g, 18.21 mmol, 2.5 eq.) in THF (80 mL) at  $-10$  °C. Stirring was continued for 2 h before the reaction was terminated by careful addition of MeOH (20 mL). A saturated aqueous Rochelle's salt solution and  $\text{Et}_2\text{O}$  was added and the mixture was allowed to reach room temperature and stirred vigorously for 5 h. The phases were separated and the aqueous phase was extracted with  $\text{Et}_2\text{O}$  (3 x 40 mL). The combined organic phases were washed with brine, dried over  $\text{MgSO}_4$ , filtered and the solvent was removed under reduced pressure. The corresponding diol **50** (1.59 g, 6.63 mmol, 91%) was obtained as a colorless oil and was of sufficient purity to be used without further purification.

The analytical data are consistent with those reported in the literature.<sup>[200]</sup>

$R_f = 0.3$  (100% EtOAc);

**$^1\text{H-NMR}$**  (400 MHz,  $\text{CDCl}_3$ ,  $\text{CHCl}_3 = 7.26$  ppm):  $\delta$  7.25 (app. d,  $J = 8.7$  Hz, 2H, PMB), 6.88 (d,  $J = 8.7$  Hz, 2H, PMB), 4.48 (s, 2H, PMB), 3.86 – 3.82 (m, 1H, H-6), 3.81 (s, 3H, PMB), 3.66 (ddd,  $J = 23.1, 10.8, 5.9$  Hz, 2H, H-3), 3.47 (dd,  $J = 9.4, 3.3$  Hz, 1H, H-7), 3.32 (dd,  $J = 9.4, 8.0$  Hz, 1H, H-7'), 2.79 (bs, 1H, OH), 2.36 (bs, 1H, OH), 1.72 – 1.66 (m, 2H, H-4), 1.63 – 1.55 (m, 1H, H-5), 1.54 – 1.44 (m, 1H, H-5') ppm;

$[\alpha]_{\text{D}}^{23} = -7.4$ <sup>13</sup> ( $c = 1.0$ , EtOH; lit.  $[\alpha]_{\text{D}}^{20} = -8.6$ ,  $c = 1.0$ , EtOH)<sup>[75]</sup>;

<sup>12</sup> apparent

<sup>13</sup> When optical rotation is measured in  $\text{CH}_2\text{Cl}_2$  the sign changes from negative to positive:  $[\alpha]_{\text{D}}^{22} = +2.4$  ( $c = 1.2$ ,  $\text{CH}_2\text{Cl}_2$ ; lit.  $[\alpha]_{\text{D}}^{20} = +1.9$ ,  $c = 1.0$ ,  $\text{CHCl}_3$ )<sup>[75]</sup>.

**HRMS-ESI**  $m/z$  for  $C_{13}H_{20}O_4Na$   $[M+Na]^+$  calc. 263.1260, found 263.1258.

**(S)-5-((*tert*-Butyldimethylsilyl)oxy)-1-((4-methoxybenzyl)oxy)pentan-2-ol (51)**

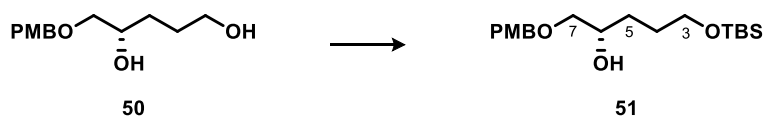

Diol **50** (10.11 g, 42.08 mmol, 1.0 eq.) was dissolved in  $CH_2Cl_2$  (105 mL) and cooled to 0 °C. Imidazole (4.30 g, 63.12 mmol, 1.5 eq.) was added and stirring was continued for a few minutes until all the material was dissolved. TBSCl (7.20 g, 46.29 mmol, 1.1 eq.) was then slowly added in portions and the mixture was stirred for 30 min at 0 °C and 3 h at room temperature. The reaction was terminated by the addition of a saturated aqueous  $NH_4Cl$  solution. The phases were separated and the aqueous phase was extracted with  $CH_2Cl_2$  (3 x 30 mL). The combined organic phases were dried over  $MgSO_4$ , filtered and the solvent was removed under reduced pressure. The crude product was purified by flash column chromatography (PE/EtOAc = 8:1  $\rightarrow$  2:1) to yield monosilylated alcohol **51** (13.23 g, 37.31 mmol, 89%) as a colorless oil.

The analytical data are consistent with those reported in the literature.<sup>[75]</sup>

$R_f$  = 0.5 (PE/EtOAc = 4:1);

**$^1H$ -NMR** (400 MHz,  $CDCl_3$ ,  $CHCl_3$  = 7.26 ppm):  $\delta$  7.26 (app. d,  $J$  = 8.7 Hz, 2H, PMB), 6.88 (app. d,  $J$  = 8.7 Hz, 2H, PMB), 4.49 (s, 2H, PMB), 3.83 – 3.77 (m, 1H, H-6), 3.81 (s, 3H, PMB), 3.64 (app. t,  $J$  = 5.9 Hz, 2H, H-3), 3.46 (dd,  $J$  = 9.4, 3.7 Hz, 1H, H-7), 3.34 (dd,  $J$  = 9.4, 7.4 Hz, 1H, H-7'), 2.80 (bs, 1H, OH), 1.69 – 1.42 (m, 4H, H-4, H-5), 0.89 (s, 9H, TBS), 0.05 (s, 6H, TBS) ppm;

$[\alpha]_D^{20}$  = -2.1 ( $c$  = 1.0,  $CH_2Cl_2$ ; lit.  $[\alpha]_D^{20}$  = -2.3,  $c$  = 1.0,  $CHCl_3$ )<sup>[75]</sup>;

**HRMS-ESI**  $m/z$  for  $C_{19}H_{34}O_4SiNa$   $[M+Na]^+$  calc. 377.2124, found 377.2124.

**(S)-*tert*-Butyl((4-methoxy-5-((4-methoxybenzyl)oxy)pentyl)oxy)dimethylsilane (52)**

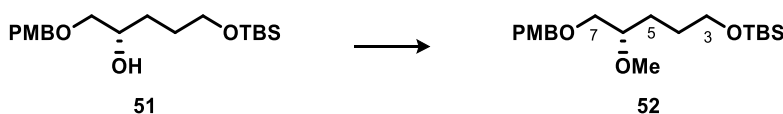

Alcohol **51** (13.06 g, 36.83 mmol, 1.0 eq.) was dissolved in THF (90 mL) and cooled to 0 °C. Sodium hydride (60% dispersion in mineral oil, 2.21 g, 55.25 mmol, 1.5 eq.) and MeI (2.52 mL, 40.51 mmol, 1.1 eq.) were added sequentially. The mixture was allowed to reach room temperature and stirring was continued for 6 h. The reaction was carefully terminated by the addition of water. The phases were separated and the aqueous phase was extracted with EtOAc (3 x 50 mL). The combined organic phases were washed with brine, dried over  $MgSO_4$ , filtered and the solvent was removed under reduced pressure. The crude product was purified by flash column chromatography (PE/EtOAc = 3.5:1) to yield methyl ether **52** (13.31 g, 36.11 mmol, 98%) as a pale-yellow oil.

The analytical data are consistent with those reported in the literature.<sup>[75]</sup>

$R_f = 0.7$  (PE/EtOAc = 2:1);

$^1\text{H-NMR}$  (400 MHz,  $\text{CDCl}_3$ ,  $\text{CHCl}_3 = 7.26$  ppm):  $\delta$  7.26 (app. d,  $J = 8.7$  Hz, 2H, PMB), 6.8 (app. d,  $J = 8.$  Hz, 2H, PMB), 4.48 (s, 2H, PMB), 3.80 (s, 3H, PMB), 3.62-3.59 (m, 2H, H-3), 3.45 (d,  $J = 4.9$  Hz, 2H, H-7), 3.40 (s, 3H, OMe), 3.37 – 3.33 (m, 1H, H-6), 1.62 – 1.48 (m, 4H, H-4, H-5), 0.89 (s, 9H, TBS), 0.04 (s, 6H, TBS) ppm;

$[\alpha]_{\text{D}}^{20} = -3.7$  ( $c = 1.0$ ,  $\text{CHCl}_3$ ; lit.  $[\alpha]_{\text{D}}^{20} = -6.0$ ,  $c = 1.0$ ,  $\text{CHCl}_3$ )<sup>[75]</sup>;

**HRMS-ESI**  $m/z$  for  $\text{C}_{20}\text{H}_{36}\text{O}_4\text{SiNa}$   $[\text{M}+\text{Na}]^+$  calc. 391.2281, found 391.2285.

**(S)-5-((tert-Butyldimethylsilyl)oxy)-2-methoxypentan-1-ol (53)**

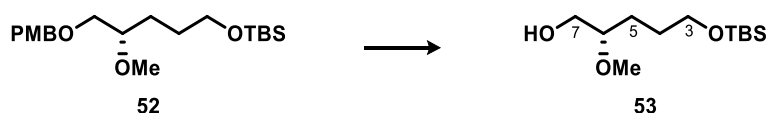

PMB ether **52** (4.62 g, 12.53 mmol, 1.0 eq.) was dissolved in  $\text{CH}_2\text{Cl}_2/\text{pH7}$  phosphate buffer (9:1, 100 mL) and was cooled to 0 °C. DDQ (3.41 g, 15.04 mmol, 1.2 eq.) was added and the mixture was allowed to reach room temperature. Stirring was continued for 5 h. The reaction was terminated by the addition of a saturated aqueous  $\text{Na}_2\text{S}_2\text{O}_3$  solution (25 mL) and a saturated aqueous  $\text{NaHCO}_3$  solution (25 mL). The resulting emulsion was broken up by addition of aqueous 10%  $\text{NaOH}$  (3 mL). The phases were separated and the aqueous phase was extracted with MTBE (4 x 100 mL). The combined organic phases were washed with brine, dried over  $\text{MgSO}_4$ , filtered and the solvent was removed under reduced pressure. The crude product was purified by flash column chromatography (PE/MTBE = 4:1  $\rightarrow$  100% MTBE) to yield alcohol **53** (2.63 g, 10.58 mmol, 96% brsm) as a yellow oil.

The analytical data are consistent with those reported in the literature.<sup>[75]</sup>

$R_f = 0.2$  (PE/EtOAc = 4:1);

$^1\text{H-NMR}$  (400 MHz,  $\text{CDCl}_3$ ,  $\text{CHCl}_3 = 7.26$  ppm):  $\delta$  3.68 (dd,  $J = 11.5, 3.4$  Hz, 1H, H-7), 3.61 (app. t,  $J = 6.0$  Hz, 2H, H-3), 3.49 (dd,  $J = 11.4, 6.6$  Hz, 1H, H-7'), 3.40 (s, 3H, OMe), 3.32-3.27 (m, 1H, H-6), 1.87 (bs, 1H, OH), 1.66 – 1.46 (m, 4H, H-4, H-5), 0.89 (s, 9H, TBS), 0.05 (s, 6H, TBS) ppm;

$[\alpha]_{\text{D}}^{20} = +14.6$  ( $c = 0.9$ ,  $\text{CH}_2\text{Cl}_2$ ; lit.  $[\alpha]_{\text{D}}^{20} = +20.0$ ,  $c = 1.0$ ,  $\text{CHCl}_3$ )<sup>[75]</sup>;

**HRMS-ESI**  $m/z$  for  $\text{C}_{12}\text{H}_{28}\text{O}_3\text{SiNa}$   $[\text{M}+\text{Na}]^+$  calc. 271.1706, found 271.1702.

**(S)-5-((tert-Butyldimethylsilyl)oxy)-2-methoxypentanal (54)**

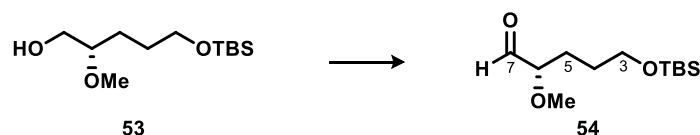

Oxalyl chloride (345  $\mu\text{L}$ , 4.03 mmol, 2.0 eq.) was dissolved in  $\text{CH}_2\text{Cl}_2$  (5 mL) and cooled to –78 °C and DMSO (571  $\mu\text{L}$ , 8.05 mmol, 4.0 eq.) was added dropwise. The resulting solution was stirred for 15 min. Alcohol **53** (500 mg, 2.01 mmol, 1.0 eq.) was slowly added as a solution in 5 mL  $\text{CH}_2\text{Cl}_2$ . Stirring was continued for 1.5 h before  $\text{Et}_3\text{N}$  (1.67 mL, 12.08 mmol,

6.0 eq.) was added dropwise. The mixture was allowed to reach room temperature and was diluted with CH<sub>2</sub>Cl<sub>2</sub>. The reaction was terminated by the addition of a saturated aqueous NH<sub>4</sub>Cl solution. The phases were separated and the aqueous phase was extracted with CH<sub>2</sub>Cl<sub>2</sub> (3 x 10 mL). The combined organic phases were washed with brine, dried over MgSO<sub>4</sub>, filtered and the solvent was removed under reduced pressure. The crude product was purified by flash column chromatography (PE/EtOAc = 10:1) to yield aldehyde **54** (424 mg, 1.72 mmol, 85%) as a colorless oil.

R<sub>f</sub> = 0.5 (PE/EtOAc = 8:1);

<sup>1</sup>H-NMR (400 MHz, CDCl<sub>3</sub>, CHCl<sub>3</sub> = 7.26 ppm): δ 9.65 (d, *J* = 2.0 Hz, 1H, CHO), 3.64 – 3.59 (m, 3H, H-6, H-3), 3.44 (s, 3H, OMe), 1.82 – 1.54 (m, 4H, H-5, H-4), 0.89 (s, 9H, TBS), 0.04 (s, 6H, TBS) ppm.

### (3*S*,4*S*)-7-((*tert*-Butyldimethylsilyl)oxy)-4-methoxy-2-methylhept-1-en-3-ol (**38**)

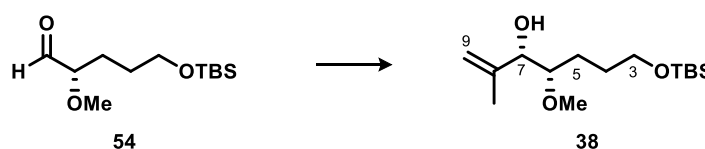

#### Procedure A

Aldehyde **54** (98 mg, 0.40 mmol, 1.0 eq.) was dissolved in THF (5 mL) and cooled to –78 °C. In a separate flask *isopropenylmagnesium bromide* (0.5 M in THF, 1.60 mL, 0.80 mmol, 2.0 eq.) was diluted in THF (5 mL) and also cooled to –78 °C. The Grignard reagent was then slowly added to the reaction flask via cannula. Stirring was continued for 30 min at this temperature and the reaction was terminated by the addition of saturated aqueous NaHCO<sub>3</sub> solution (5 mL). The mixture was diluted with EtOAc (10 mL) and allowed to reach room temperature. The phases were separated and the aqueous phase was extracted with EtOAc (3 x 5 mL). The combined organic phases were washed with brine, dried over MgSO<sub>4</sub>, filtered and the solvent was removed under reduced pressure. The crude product was purified by flash column chromatography (PE/EtOAc = 10:1 → 3:1) to yield allylic alcohol **38** (70 mg, 0.24 mmol, *d.r.* = 4:1, 60%) as a colorless oil.

#### Procedure B

*Isopropenylmagnesium bromide* (0.5 M in THF, 12.4 mL, 6.19 mmol, 5.0 eq.) was placed in a flame-dried schlenk flask and the solvent was evaporated on a rotovap (water bath temperature 35 °C, 30 mbar). Upon complete dryness, the rotovap and the flask were fitted with an argon-filled balloon and ventilated. CH<sub>2</sub>Cl<sub>2</sub> (6 mL) was added to the flask and the solvent was removed under reduced pressure applying the same venting technique. The remaining *isopropenylmagnesium bromide* was then dissolved in CH<sub>2</sub>Cl<sub>2</sub> (12.38 mL) to obtain a 0.5 M solution which was cooled to 0 °C. ZnCl<sub>2</sub> (421 mg, 3.09 mmol, 2.5 eq.) from a glovebox was added under an argon flow. The mixture was allowed to reach room temperature and stirring was continued for 5 h to give a clear pale-yellow solution. The mixture was then cooled to –78 °C and aldehyde **54** (305 mg, 1.24 mmol, 1.0 eq.) was added slowly as a 0.05 M solution in PhMe via a syringe pump. Stirring was continued at –78 °C for

30 min and at 0 °C for 30 min. The reaction was terminated by the addition of a saturated aqueous NH<sub>4</sub>Cl solution and filtered through Celite®. The phases were separated and the aqueous phase was extracted with EtOAc (3 x 20 mL). The combined organic phases were dried over MgSO<sub>4</sub>, filtered and the solvent was removed under reduced pressure. The crude product was purified by flash column chromatography (PE/EtOAc = 10:1 → 3:1) to yield allylic alcohol **38** (238 mg, 0.83 mmol, *d.r.* = 19:1, 67%) as a colorless oil.

The analytical data are consistent with those reported in the literature.<sup>[80]</sup>

**R<sub>f</sub>** = 0.7 (PE/EtOAc = 1:1);

**<sup>1</sup>H-NMR** (400 MHz, CDCl<sub>3</sub>, CHCl<sub>3</sub> = 7.26 ppm): δ 5.03 – 5.02 (m, 1H, H-9), 4.94 – 4.93 (m, 1H, H-9'), 3.94 (d, *J* = 6.8 Hz, 1H, H-7), 3.62 – 3.59 (m, 2H, H-3), 3.42 (s, 3H, OMe), 3.27 – 3.23 (m, 1H, H-6), 1.75 (s, 3H, Me-8), 1.67 – 1.55 (m, 4H, H-4, H-5), 0.89 (s, 9H, TBS), 0.04 (s, 6H, TBS) ppm;

**<sup>13</sup>C-NMR** (400 MHz, CDCl<sub>3</sub>, CHCl<sub>3</sub> = 77.16 ppm): δ 144.4 (s, C-8), 114.1 (t, C-9), 82.1 (t, C-6), 77.4 (d, C-7), 63.2 (t, C-3), 58.0 (q, OMe), 28.2 (t, C-4), 26.4 (t, C-5), 26.1 (q, 3C, TBS), 18.5 (s, TBS), 18.0 (q, Me-8), -5.2 (q, 2C, TBS) ppm;

**[α]<sub>D</sub><sup>21</sup>** = +18.1 (*c* = 1.0, CH<sub>2</sub>Cl<sub>2</sub>; lit. **[α]<sub>D</sub><sup>20</sup>** = +22.5, *c* = 2.0, CH<sub>2</sub>Cl<sub>2</sub>)<sup>[80]</sup>;

**HRMS-ESI** *m/z* for C<sub>15</sub>H<sub>32</sub>O<sub>3</sub>SiNa [M+Na]<sup>+</sup> calc. 311.2018, found 311.2016.

**(8*S*,9*S*)-11-Chloro-11-isopropyl-8-methoxy-2,2,3,3,12-pentamethyl-9-(prop-1-en-2-yl)-4,10-dioxa-3,11-disilatridecane (85)**

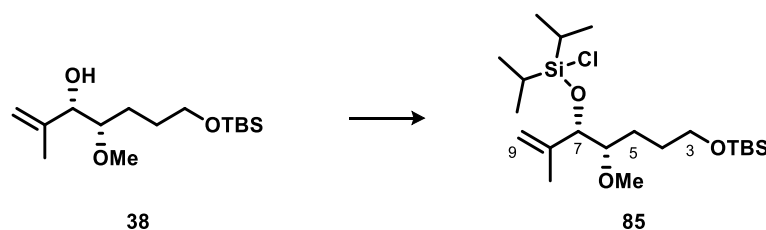

Imidazole (17 mg, 0.243 mmol, 5.0 eq.) was dissolved in CH<sub>2</sub>Cl<sub>2</sub> (1 mL) and cooled to 0 °C. (*i*-Pr)<sub>2</sub>Si(Cl)<sub>2</sub> (39 μL, 0.218 mmol, 4.5 eq.) was added dropwise and stirring was continued for 5 min. Alcohol **38** (14 mg, 0.049 mmol, 1.0 eq.) was added as a solution in CH<sub>2</sub>Cl<sub>2</sub> (1 mL) dropwise over 10 min. The reaction was stirred overnight and allowed to reach room temperature. The solvent was removed under reduced pressure and the resulting solid residue was suspended in hexane (2 mL). After allowing the solids to settle, the supernatant was transferred into a new flask. This procedure was repeated six times and the combined hexane phases were concentrated under reduced pressure. Excess (*i*-Pr)<sub>2</sub>Si(Cl)<sub>2</sub> was removed from the resulting oil by Kugelrohr distillation (1.5 mbar, 75 °C, 3 h) to yield silyl ether **85** (19 mg, 0.043 mmol, 88%) as a colorless oil.

**R<sub>f</sub>** = 0.6 (PE/EtOAc = 4:1);

**<sup>1</sup>H-NMR** (400 MHz, CDCl<sub>3</sub>, CHCl<sub>3</sub> = 7.26 ppm): δ 4.90 (s, 1H, H-9), 4.85 (s, 1H, H-9'), 4.20 (d, *J* = 7.9 Hz, 1H, H-7), 3.63 – 3.52 (m, 2H, H-3), 3.43 (s, 3H, OMe), 3.22 – 3.17 (m, 2H, H-6), 1.72 (s, 3H, Me-8), 1.63 – 1.55 (m, 4H, H-4, H-5), 1.31 – 1.25 (m, 2H, *i*-Pr), 1.07 – 1.00 (m, 12H, *i*-Pr), 0.88 (s, 9H, TBS), 0.04 (s, 6H, TBS) ppm;

**HRMS-ESI** *m/z* for C<sub>21</sub>H<sub>45</sub>ClO<sub>3</sub>Si<sub>2</sub>Na [M+Na]<sup>+</sup> calc. 459.2494, found 459.2491.



**4-(((3*S*,4*S*)-7-((*tert*-Butyldimethylsilyl)oxy)-4-methoxy-2-methylhept-1-en-3-yl)oxy)-4-oxobutanoic acid (**89**)**

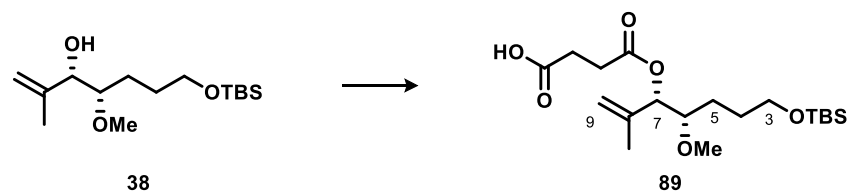

Alcohol **38** (141 mg, 0.489 mmol, 1.0 eq.) was dissolved in CH<sub>2</sub>Cl<sub>2</sub> (20 mL) and succinic anhydride (196 mg, 1.96 mmol, 4.0 eq.) and DMAP (239 mg, 1.96 mmol, 4.0 eq.) were added successively. The mixture was stirred at room temperature for 72 h before the reaction was terminated by the addition of an aqueous 1 M HCl solution. The phases were separated and the aqueous phase was extracted with EtOAc (3 x 15 mL). The combined organic phases were washed with brine, dried over MgSO<sub>4</sub> and filtered. The solvent was removed under reduced pressure to yield acid **89** (185 mg, 0.476 mmol, 97%) as a colorless oil which was used in the next step without further purification.

<sup>1</sup>H-NMR (400 MHz, CDCl<sub>3</sub>, CHCl<sub>3</sub> = 7.26 ppm): δ 9.63 (bs, 1H, COOH), 5.20 (d, *J* = 6.0 Hz, 1H, H-7), 4.99 (s, 1H, H-9), 4.94 (s, 1H, H-9'), 3.64 – 3.55 (m, 2H, H-3), 3.41 (s, 3H, OMe), 3.38 – 3.33 (m, 1H, H-6), 2.67 (s, 4H, -(CH<sub>2</sub>)<sub>2</sub>COOH), 1.74 (s, 3H, Me-8), 1.68 – 1.40 (m, 4H, H-4, H-5), 0.87 (s, 9H, TBS), 0.03 (s, 6H, TBS) ppm;

<sup>13</sup>C-NMR (400 MHz, CDCl<sub>3</sub>, CDCl<sub>3</sub> = 77.16 ppm): δ 177.1 (s, -COOH), 171.4 (s, -COO-), 141.0 (s, C-8), 114.6 (t, C-9), 81.1 (d, C-6), 78.8 (d, C-7), 63.2 (t, C-3), 58.8 (q, OMe), 29.3 (t, -CH<sub>2</sub>COO-), 29.0 (t, -CH<sub>2</sub>COOH), 28.6 (t, C-4), 27.0 (t, C-5), 26.1 (q, 3C, TBS), 19.3 (q, Me-8), 18.5 (s, TBS), -5.2 (q, 2C, TBS) ppm;

[α]<sub>D</sub><sup>20</sup> = -6.0 (*c* = 1.0, CHCl<sub>3</sub>);

HRMS-ESI *m/z* for C<sub>19</sub>H<sub>35</sub>O<sub>6</sub>Si [M-H]<sup>-</sup> calc. 387.2208, found 387.2210.

### 5.3.2 Western Fragment

#### Methyl 3-amino-5-hydroxybenzoate (**56**)

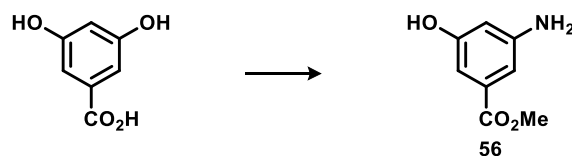

3,5-Dihydroxybenzoic acid (41.6 g, 269.9 mmol, 1.0 eq.) and NH<sub>4</sub>Cl (36.1 g, 674.8 mmol, 2.5 eq.) were suspended in aqueous NH<sub>3</sub> (28%, 140 mL) in an autoclave (model T304, Parr Instrument Company) and heated to 180 °C for 40 h. The reaction mixture was allowed to cool to room temperature, concentrated under reduced pressure and afterwards MeOH (500 mL) was added. Then, H<sub>2</sub>SO<sub>4</sub> (conc., 58 mL, 1.08 mol, 4.0 eq.) was added dropwise and the solution was stirred under refluxing conditions for 36 h. The solvent was removed under reduced pressure and the residue was treated with ice-cold water. The aqueous phase was extracted with diethyl ether (2 x 200 mL). The organic phase was discarded and the aqueous

phase was neutralized with solid  $\text{NaHCO}_3$  and extracted with EtOAc (3 x 250 mL). The combined organic phases were washed with brine (1 x 100 mL), dried over  $\text{MgSO}_4$ , filtered and concentrated under reduced pressure to obtain the crude arene **56** (31.1 g, 186.2 mmol, 69%) as a red solid, which was used in the following step without further purification.

The analytical data are consistent with those reported in the literature.<sup>[201]</sup>

**$^1\text{H-NMR}$**  (400 MHz, acetone- $d_6$ , acetone- $d_5 = 2.05$  ppm):  $\delta$  8.25 (bs, 1H, OH), 6.85 (dd,  $J = 2.2, 1.4$  Hz, 1H, H-2), 6.76 (dd,  $J = 2.2, 1.4$  Hz, 1H, H-6), 6.41 (t,  $J = 2.2$  Hz, 1H, H-4), 4.80 (bs, 2H,  $\text{NH}_2$ ), 3.79 (s, 3H,  $\text{CO}_2\text{Me}$ ) ppm.

### Methyl 3-[(*tert*-butoxycarbonyl)amino]-5-hydroxybenzoate (**350**)

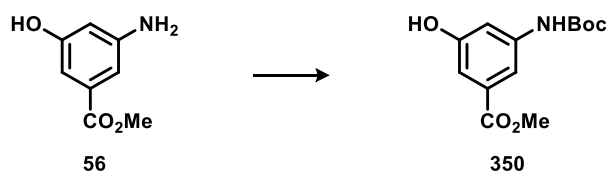

Aniline **56** (31.1 g, 186.2 mmol, 1.0 eq.) was dissolved in THF (150 mL) and a saturated aqueous  $\text{NaHCO}_3$  solution (400 mL) was added. Then, di-*tert*-butyl dicarbonate (40.7 g, 186.2 mmol, 1.0 eq) was added and stirring was continued at room temperature for 27 h. Excess of THF was removed under reduced pressure and the aqueous phase was extracted with EtOAc (3 x 200 mL). The combined organic phases were dried over  $\text{MgSO}_4$ , filtered and the solvent was removed under reduced pressure. The crude product was then purified by crystallization from  $\text{CH}_2\text{Cl}_2$  to yield carbamate **350** (44.8 g, 167.6 mmol, 90%) as a colorless solid.

The analytical data are consistent with those reported in the literature.<sup>[202]</sup>

$R_f = 0.2$  (PE/EtOAc = 4:1);

**$^1\text{H-NMR}$**  (400 MHz, acetone- $d_6$ , acetone- $d_5 = 2.05$  ppm):  $\delta$  8.58 (s, 1H, NH), 8.46 (bs, 1H, OH), 7.67 (s, 1H, H-4), 7.34 (s, 1H, H-2), 7.07 (s, 1H, H-6), 3.80 (s, 3H, OMe), 1.44 (s, 9H, Boc) ppm;

**m.p.** 144 °C (lit. 146 °C)<sup>[202]</sup>.

### Methyl 3-[(*tert*-butoxycarbonyl)amino]-5-[(*tert*-butyldiphenylsilyl)oxy]benzoate (**351**)

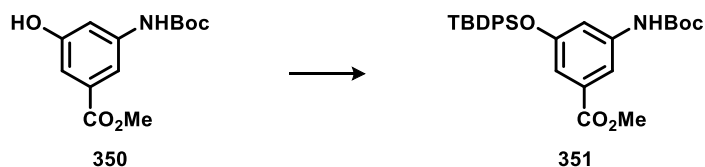

Phenol **350** (7.1 g, 26.54 mmol, 1.0 eq.) was dissolved in  $\text{CH}_2\text{Cl}_2$  (300 mL) under nitrogen atmosphere. Imidazole (2.17 g, 31.85 mmol, 1.2 eq.) and DMAP (0.33 g, 2.65 mmol, 0.1 eq.) were added subsequently. Then, TBDPS-Cl (10.3 mL, 39.81 mmol, 1.5 eq.) was added and the reaction was stirred at 35 °C for 10 h. The reaction was terminated by the addition of a saturated  $\text{NH}_4\text{Cl}$  solution and the aqueous phase was extracted with  $\text{CH}_2\text{Cl}_2$  (3 x 100 mL).

The combined organic phases were dried over  $\text{MgSO}_4$ , filtered and the solvent was removed under reduced pressure. The crude product was purified by flash column chromatography (PE/EtOAc = 50:1  $\rightarrow$  10:1) to furnish ester **351** (11.27 g, 22.29 mmol, 84%) as a colorless foam.

The analytical data are consistent with those reported in the literature.<sup>[202]</sup>

$R_f$  = 0.4 (PE/EtOAc = 4:1);

**$^1\text{H-NMR}$**  (400 MHz,  $\text{CDCl}_3$ ,  $\text{CHCl}_3$  = 7.26 ppm):  $\delta$  7.72 – 7.69 (m, 4H, TBDPS), 7.62 (s, 1H,  $\text{H}_{\text{Ar}}$ ), 7.45 – 7.35 (m, 6H, TBDPS), 7.09 (m, 1H,  $\text{H}_{\text{Ar}}$ ), 6.94 (s, 1H,  $\text{H}_{\text{Ar}}$ ), 6.32 (s, 1H, NH), 3.79 (s, 3H,  $\text{CO}_2\text{Me}$ ), 1.47 (s, 9H, Boc), 1.09 (s, 9H, TBDPS) ppm;

**$^{13}\text{C-NMR}$**  (400 MHz,  $\text{CDCl}_3$ ,  $\text{CDCl}_3$  = 77.16 ppm):  $\delta$  166.7 (s,  $\text{CO}_2\text{Me}$ ), 156.2 (s,  $\text{C}_{\text{Ar}}$ ), 152.4 (s, Boc), 139.5 (s,  $\text{C}_{\text{Ar}}$ ), 135.7 (d, 4C, TBDPS), 132.5 (s, 2C, TBDPS), 131.8 (d, TBDPS), 130.2 (d, TBDPS), 128.0 (d, 4C, TBDPS), 115.6 (d,  $\text{C}_{\text{Ar}}$ ), 114.3 (d,  $\text{C}_{\text{Ar}}$ ), 112.5 (d,  $\text{C}_{\text{Ar}}$ ), 80.9 (s, Boc), 52.2 (q,  $\text{CO}_2\text{Me}$ ), 28.4 (q, 3C, Boc), 26.6 (q, 3C, TBDPS), 19.6 (s, TBDPS) ppm;

**HRMS-ESI**  $m/z$  for  $\text{C}_{29}\text{H}_{35}\text{NO}_5\text{SiNa}$  [ $\text{M}+\text{Na}$ ] $^+$  calc. 528.2182, found 528.2180.

### *tert*-Butyl {3-[(*tert*-butyldiphenylsilyloxy)]-5-(hydroxymethyl)phenyl}carbamate (**37**)

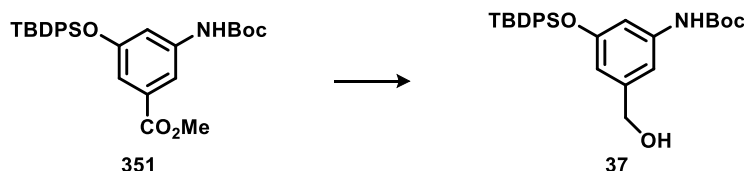

Ester **351** (9.65 g, 19.08 mmol, 1.0 eq.) was dissolved in dry THF (80 mL) and cooled to  $-78$  °C. DIBAL-H (1.0 M in hexane, 57.23 mL, 57.23 mmol, 3.0 eq) was added slowly and stirring was continued for 30 min. After warming to room temperature and stirring for 17 h, the reaction was again cooled to  $0$  °C and a saturated aqueous Rochelle's salt solution was added. The mixture was stirred at room temperature for 12 h. The phases were separated and the aqueous phase was extracted with EtOAc (3 x 150 mL). The combined organic phases were dried over  $\text{MgSO}_4$ , filtered and the solvent was removed under reduced pressure. The crude product was purified by flash column chromatography (PE/EtOAc: 4:1  $\rightarrow$  2:1) to yield benzylic alcohol **37** (8.53 g, 17.86 mmol, 93%) as a colorless foam.

The analytical data are consistent with those reported in the literature.<sup>[203]</sup>

$R_f$  = 0.1 (PE/EtOAc = 4:1);

**$^1\text{H-NMR}$**  (400 MHz,  $\text{CDCl}_3$ ,  $\text{CHCl}_3$  = 7.26 ppm):  $\delta$  7.72 – 7.69 (m, 4H, TBDPS), 7.44 – 7.34 (m, 6H, TBDPS), 7.08 (bs, 1H,  $\text{H}_{\text{Ar}}$ ), 6.58 (m, 1H,  $\text{H}_{\text{Ar}}$ ), 6.41 – 6.40 (m, 1H,  $\text{H}_{\text{Ar}}$ ), 6.27 (bs, 1H, NH), 4.43 (s, 2H,  $\text{CH}_2\text{OH}$ ), 1.47 (s, 9H, Boc), 1.08 (s, 9H, TBDPSS) ppm;

**$^{13}\text{C-NMR}$**  (400 MHz,  $\text{CDCl}_3$ ,  $\text{CDCl}_3$  = 77.16 ppm):  $\delta$  156.4 (s,  $\text{C}_{\text{Ar}}$ ), 152.6 (s, Boc), 143.1 (s,  $\text{C}_{\text{Ar}}$ ), 139.5 (s,  $\text{C}_{\text{Ar}}$ ), 135.6 (d, 4C, TBDPS), 132.9 (s, 2C, TBDPS), 130.1 (d, 2C, TBDPS), 127.9 d, 4C, TBDPS), 112.9 (d,  $\text{C}_{\text{Ar}}$ ), 109.8 (d,  $\text{C}_{\text{Ar}}$ ), 109.1 (d,  $\text{C}_{\text{Ar}}$ ), 80.7 (s, Boc), 65.2 (t,  $\text{CH}_2\text{OH}$ ), 28.4 (q, 3C, Boc), 26.6 (q, 3C, TBDPS), 19.6 (s, TBDPS) ppm;

**HRMS-ESI**  $m/z$  for  $\text{C}_{28}\text{H}_{35}\text{NO}_4\text{SiNa}$  [ $\text{M}+\text{Na}$ ] $^+$  calc. 500.2233, found 500.2234.

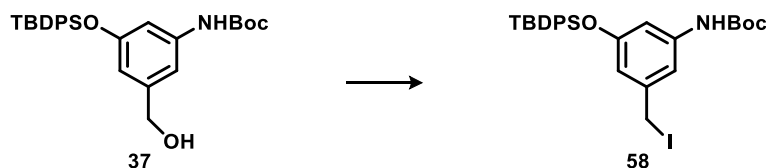
***tert*-Butyl {3-[(*tert*-butyldiphenylsilyl)oxy]-5-(iodomethyl)phenyl}carbamate (**58**)**

PPh<sub>3</sub> (9.73 g, 37.0 mmol, 1.2 eq.) and imidazole (2.53 g, 37.0 mmol, 1.2 eq.) were dissolved in CH<sub>2</sub>Cl<sub>2</sub> (300 mL) at room temperature. The reaction was cooled to 0 °C and iodine (9.39 g, 37.0 mmol, 1.2 eq.) was added in the absence of light. Stirring was continued at this temperature for 30 minutes. Benzylic alcohol **37** (14.7 g, 30.8 mmol, 1.0 eq.) dissolved in CH<sub>2</sub>Cl<sub>2</sub> (50 mL) was added via canula. The reaction was stirred at 0 °C for 4 h. Silica gel was added and the solvent was removed under reduced pressure. The crude product was purified by flash column chromatography (PE/EtOAc = 10:1 → 6:1) to yield benzylic iodide **58** (16.29 g, 27.72 mmol, 90%) as a pale-yellow oil.

The analytical data are consistent with those reported in the literature.<sup>[203]</sup>

**R<sub>f</sub>** = 0.7 (PE/EtOAc = 4:1);

**<sup>1</sup>H-NMR** (400 MHz, CDCl<sub>3</sub>, CHCl<sub>3</sub> = 7.26 ppm): δ 7.71 – 7.69 (m, 4H, TBDPS), 7.43 – 7.36 (m, 6H, TBDPS), 7.12 (bs, 1H, C<sub>Ar</sub>), 6.55 – 6.54 (m, 1H, C<sub>Ar</sub>), 6.40 – 6.39 (m, 1H, C<sub>Ar</sub>), 6.25 (bs, 1H, NH), 4.18 (s, 2H, CH<sub>2</sub>I), 1.48 (s, 9H, Boc), 1.09 (s, 9H, TBDPS) ppm;

**<sup>13</sup>C-NMR** (400 MHz, CDCl<sub>3</sub>, CDCl<sub>3</sub> = 77.16 ppm): δ 156.2 (s, C<sub>Ar</sub>), 152.5 (s, Boc), 140.9 (s, C<sub>Ar</sub>), 139.5 (s, C<sub>Ar</sub>), 135.6 (d, 4C, TBDPS), 132.7 (s, 2C, TBDPS), 130.1 (d, 2C, TBDPS), 128.0 (d, 4C, TBDPS), 115.1 (d, C<sub>Ar</sub>), 111.7 (d, C<sub>Ar</sub>), 109.5 (d, C<sub>Ar</sub>), 80.8 (s, Boc), 28.4 (q, 3C, Boc), 26.6 (q, 3C, TBDPS), 19.6 (s, TBDPS), 5.5 (t, CH<sub>2</sub>I) ppm;

**HRMS-ESI** *m/z* for C<sub>28</sub>H<sub>34</sub>INO<sub>3</sub>SiNa [M+Na]<sup>+</sup> calc. 610.1250, found 610.1248.

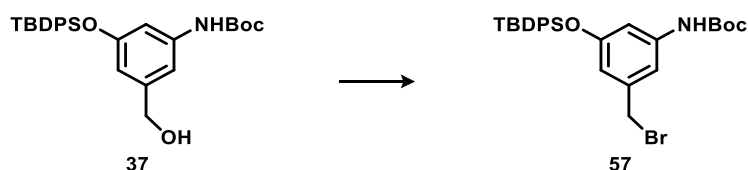
***tert*-Butyl {3-(bromomethyl)-5-[(*tert*-butyldiphenylsilyl)oxy]phenyl}carbamate (**57**)**

Benzylic alcohol **37** (8.47 g, 17.73 mmol, 1.0 eq.) was dissolved in CH<sub>2</sub>Cl<sub>2</sub> (70 mL), PPh<sub>3</sub> (5.58 g, 21.27 mmol, 1.2 eq.) and CBr<sub>4</sub> (7.05 g, 21.27 mmol, 1.2 eq.) were added sequentially and stirring was continued at room temperature for 45 min. Silica gel (100 mL) was added and the solvent was removed under reduced pressure. The crude product was purified by flash column chromatography (PE/EtOAc = 25:1 → 4:1) to yield benzylic bromide **57** (8.81 g, 16.29 mmol, 92%) as a brown foam.

The analytical data are consistent with those reported in the literature.<sup>[203]</sup>

**R<sub>f</sub>** = 0.6 (PE/EtOAc = 4:1);

**<sup>1</sup>H-NMR** (400 MHz, CDCl<sub>3</sub>, CHCl<sub>3</sub> = 7.26 ppm): δ 7.72 – 7.69 (m, 4H, TBDPS), 7.45 – 7.35 (m, 6H, TBDPS), 7.15 (bs, 1H, H<sub>Ar</sub>), 6.57 – 6.56 (m, 1H, H<sub>Ar</sub>), 6.43 – 6.42 (m, 1H, H<sub>Ar</sub>), 6.25 (bs, 1H, NH), 4.22 (s, 2H, CH<sub>2</sub>Br), 1.47 (s, 9H, Boc), 1.09 (s, 9H, TBDPS) ppm;

$^{13}\text{C-NMR}$  (400 MHz,  $\text{CDCl}_3$ ,  $\text{CDCl}_3 = 77.16$  ppm):  $\delta$  156.1 (s,  $\text{C}_{\text{Ar}}$ ), 152.4 (s, Boc), 139.5 (s,  $\text{C}_{\text{Ar}}$ ), 139.4 (s,  $\text{C}_{\text{Ar}}$ ), 135.5 (d, 4C, TBDPS), 132.5 (s, 2C, TBDPS), 130.0 (d, 2C, TBDPS), 127.9 (d, 4C, TBDPS), 115.2 (d,  $\text{C}_{\text{Ar}}$ ), 111.8 (d,  $\text{C}_{\text{Ar}}$ ), 109.8 (d,  $\text{C}_{\text{Ar}}$ ), 80.7 ((s, Boc), 33.3 (t,  $\text{CH}_2\text{Br}$ ), 28.3 (q, 3C, Boc), 26.5 (q, 3C, TBDPS), 19.5 (s, TBDPS) ppm;

**HRMS-ESI**  $m/z$  for  $\text{C}_{28}\text{H}_{34}\text{BrNO}_3\text{SiNa}$  [ $\text{M}+\text{Na}$ ] $^+$  calc. 562.1389, found 562.1389.

***tert*-Butyl {3-[(*tert*-butyldiphenylsilyloxy)-5-(iodomethyl)phenyl]carbamate (**58**)**

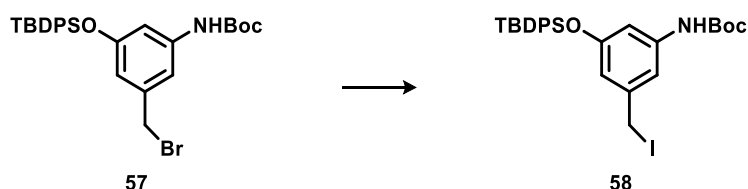

Bromide **57** (18.71 g, 34.62 mmol, 1.0 eq.) was dissolved in acetone (40 mL) and sodium iodide (7.78 g, 51.93 mmol, 1.5 eq.) was added. The reaction mixture was stirred at room temperature for 2 h. Water was added and the aqueous phase was extracted with  $\text{CH}_2\text{Cl}_2$  (3 x 150 mL). The combined organic phases were washed with brine, dried over  $\text{MgSO}_4$ , filtered and the solvent was removed under reduced pressure to yield iodide **58** (19.58 g, 33.33 mmol, 96%) as a yellow foam.

The analytical data are consistent with those reported on page 110.

***tert*-Butyl {3-[(*R*)-3-[(*S*)-4-benzyl-2-oxooxazolidin-3-yl]-2-methyl-3-oxopropyl]-5-[(*tert*-butyldiphenylsilyloxy)phenyl]carbamate (**60**)**

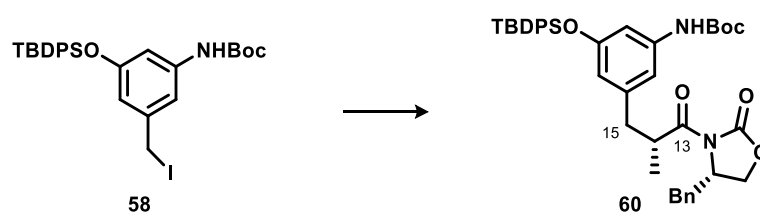

DIPA (1.29 mL, 9.24 mmol, 1.7 eq.) was dissolved in THF (25 mL) and cooled to  $-78$  °C. *n*-BuLi (2.5 M in hexane, 3.69 mL, 9.24 mmol, 1.7 eq.) was added slowly and stirring was continued at  $-78$  °C for 5 min. (*S*)-Oxazolidinone **59** (2.16 g, 9.24 mmol, 1.7 eq.) was added as a solution in THF (20 mL) via cannula. Stirring was continued for 15 min at  $-78$  °C. Iodide **58** (3.19 g, 5.44 mmol, 1.0 eq.) was added as a solution in THF (30 mL) via cannula. The reaction was stirred at  $-78$  °C for 15 min and then slowly warmed to  $-35$  °C over 2.5 h. The reaction was terminated by the addition of an aqueous saturated  $\text{NH}_4\text{Cl}$  solution. The phases were separated and the aqueous phase was extracted with EtOAc (6 x 75 mL). The combined organic phases were dried over  $\text{MgSO}_4$ , filtered and the solvent was removed under reduced pressure. The crude product was purified by flash column chromatography (PE/EtOAc = 10:1  $\rightarrow$  2:1) to yield **60** (3.14 g, 4.53 mmol, 83%) as a yellow foam.

The analytical data are consistent with those reported in the literature.<sup>[203]</sup>

$R_f$  = 0.2 (PE/EtOAc = 4:1);

**<sup>1</sup>H-NMR** (400 MHz, CDCl<sub>3</sub>, CHCl<sub>3</sub> = 7.26 ppm):  $\delta$  7.71 – 7.68 (m, 4H, TBDPS), 7.43 – 7.24 (m, 9H, TBDPS, Bn), 7.12 – 7.10 (m, 2H, Bn), 6.86 (bs, 1H, H<sub>Ar</sub>), 6.73 (bs, 1H, NH), 6.29 (m, 1H, H<sub>Ar</sub>), 6.25 (bs, 1H, H<sub>Ar</sub>), 4.67 – 4.61 (m, 1H, CHBn), 4.18 – 4.10 (m, 2H, CH<sub>2</sub>CHBn), 3.86 – 3.81 (m, 1H, C-14), 3.16 (dd,  $J$  = 13.4, 3.2 Hz, 1H, Bn), 2.93 (dd,  $J$  = 13.2, 6.2 Hz, 1H, C-15), 2.60 (dd,  $J$  = 13.4, 9.5 Hz, 1H, Bn), 2.33 (dd,  $J$  = 13.2, 8.4 Hz, 1H, C-15), 1.45 (s, 9H, Boc), 1.07 (s, 9H, TBDPS), 0.93 (d,  $J$  = 6.7 Hz, 3H, Me-14) ppm;

**<sup>13</sup>C-NMR** (400 MHz, CDCl<sub>3</sub>, CDCl<sub>3</sub> = 77.16 ppm):  $\delta$  176.6 (s, C-13), 156.1 (s, C<sub>Ar</sub>), 153.1 (s, Aux), 152.5 (s, Boc), 140.9 (s, C<sub>Ar</sub>), 139.3 (s, C<sub>Ar</sub>), 135.7 (d, 4C, TBDPS), 135.6 (s, Bn), 133.0 (s, 2C, TBDPS), 132.9 (d, Bn), 129.9 (d, 2C, TBDPS), 129.5 (d, Bn), 129.0 (d, Bn), 127.9 (d, 4C, TBDPS), 127.8 (d, Bn), 127.4 (d, Bn), 115.8 (d, C<sub>Ar</sub>), 112.2 (d, C<sub>Ar</sub>), 108.2 (d, C<sub>Ar</sub>), 80.5 (s, Boc), 66.1 (t, CH<sub>2</sub>O), 55.3 (d, CHN), 39.7 (s, Bn), 39.5 (d, C-14), 38.0 (t, C-15), 28.4 (q, 3C, Boc), 26.6 (q, 3C, TBDPS), 19.6 (s, TBDPS), 16.2 (q, Me-14) ppm;

$[\alpha]_{\text{D}}^{20} = -2.4$  ( $c = 1.0$ , CHCl<sub>3</sub>; lit.  $[\alpha]_{\text{D}}^{20} = -3.4$ ,  $c = 1.5$ , CHCl<sub>3</sub>);<sup>[204]</sup>

**HRMS-ESI**  $m/z$  for C<sub>41</sub>H<sub>48</sub>N<sub>2</sub>O<sub>6</sub>SiNa [M+Na]<sup>+</sup> calc. 715.3179, found 715.3179.

***tert*-Butyl (*R*)-3-((*tert*-butyldiphenylsilyloxy)-5-(3-hydroxy-2-methylpropyl)phenyl)carbamate (**61**)**

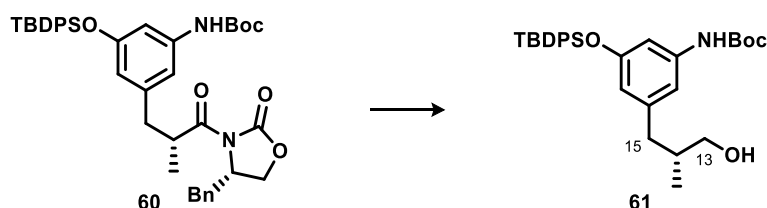

Compound **60** (21.95 g, 31.68 mmol, 1.0 eq.) was dissolved in Et<sub>2</sub>O (300 mL) and water (570  $\mu$ L, 31.68 mmol, 1.0 eq.) was added. The reaction was cooled to 0 °C and LiBH<sub>4</sub> (34.8 mL, 69.69 mmol, 2.2 eq.) was added slowly. Stirring was continued for 1 h and the reaction was terminated by the addition of an aqueous saturated NH<sub>4</sub>Cl solution. The phases were separated and the aqueous phase was extracted with EtOAc (3 x 200 mL). The combined organic phases were washed with brine, dried over MgSO<sub>4</sub>, filtered and the solvent was removed under reduced pressure. The crude product was purified by flash column chromatography (PE/EtOAc = 9:1  $\rightarrow$  4:1) to yield alcohol **61** (12.76 g, 24.57 mmol, 78%) as a yellow foam.

The analytical data are consistent with those reported in the literature.<sup>[203]</sup>

$R_f = 0.3$  (PE/EtOAc = 2:1);

**<sup>1</sup>H-NMR** (400 MHz, CDCl<sub>3</sub>, CHCl<sub>3</sub> = 7.26 ppm):  $\delta$  7.72 – 7.70 (m, 4H, TBDPS), 7.42 – 7.34 (m, 6H, TBDPS), 6.81 (bs, 1H, H<sub>Ar</sub>), 6.69 (t,  $J$  = 2.0 Hz, 1H, H<sub>Ar</sub>), 6.30 (bs, 1H, NH), 6.11 (t,  $J$  = 1.6 Hz, 1H, H<sub>Ar</sub>), 3.26 (dd,  $J$  = 10.5, 5.6 Hz, 1H, H-13), 3.19 (dd,  $J$  = 10.6, 5.9 Hz, 1H, H-13'), 2.40 (dd,  $J$  = 13.2, 6.7 Hz, 1H, H-15), 2.16 (dd,  $J$  = 13.3, 7.6 Hz, 1H, H-15'), 1.67 – 1.59 (m, 1H, H-14), 1.49 (s, 9H, Boc), 1.08 (s, 9H, TBDPS), 0.70 (d,  $J$  = 6.7 Hz, 3H, Me-14) ppm;

**<sup>13</sup>C-NMR** (400 MHz, CDCl<sub>3</sub>, CDCl<sub>3</sub> = 77.16 ppm):  $\delta$  156.0 (s, C<sub>Ar</sub>), 152.7 (s, Boc), 142.5 (s, C<sub>Ar</sub>), 139.2 (s, C<sub>Ar</sub>), 135.7 (d, 4C, TBDPS), 133.0 (s, 2C, TBDPS), 129.9 (d, 2C, TBDPS), 127.9 (d, 4C, TBDPS), 115.5 (d, C<sub>Ar</sub>), 112.1 (d, C<sub>Ar</sub>), 107.7 (d, C<sub>Ar</sub>), 80.5 (s, Boc), 67.3 (t, C-

13), 39.6 (t, C-15), 37.5 (d, C-14), 28.5 (q, 3C, Boc), 26.6 (q, 3C, TBDPS), 19.6 (s, TBDPS), 16.6 (q, Me-14) ppm;

$[\alpha]_{\text{D}}^{20} = +1.7$  ( $c = 1.2$ ,  $\text{CHCl}_3$ ; lit.  $[\alpha]_{\text{D}}^{20} = +4.9$ ,  $c = 1.0$ ,  $\text{CHCl}_3$ );<sup>[204]</sup>

**HRMS-ESI**  $m/z$  for  $\text{C}_{31}\text{H}_{41}\text{NO}_4\text{SiNa}$   $[\text{M}+\text{Na}]^+$  calc. 542.2703, found 542.2703.

***tert*-Butyl (*R*)-3-((*tert*-butyldiphenylsilyl)oxy)-5-(3-iodo-2-methylpropyl)phenylcarbamate (**64**)**

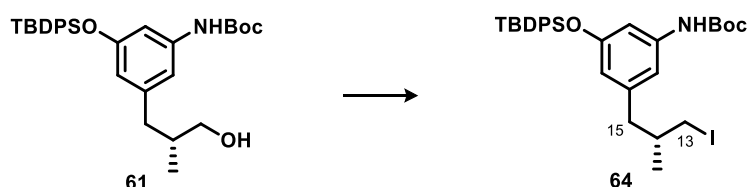

$\text{PPh}_3$  (48 mg, 0.181 mmol, 1.2 eq.) was dissolved in  $\text{CH}_2\text{Cl}_2$  (3 mL) and imidazole (15 mg, 0.227 mmol, 1.5 eq.) was added, followed by iodine (50 mg, 0.196 mmol, 1.3 eq.). The mixture was stirred at room temperature until all the material was dissolved. Alcohol **61** (79 mg, 0.151 mmol, 1.0 eq.) as a solution in  $\text{CH}_2\text{Cl}_2$  (9 mL) was added and stirring was continued for 2.5 h. Silica gel was added and the crude product was purified by flash column chromatography (dry-loading, PE/EtOAc = 4:1) to yield iodide **64** (92 mg, 0.146 mmol, 97%) as a colorless foam.

$R_f = 0.6$  (PE/EtOAc = 4:1);

**$^1\text{H-NMR}$**  (400 MHz,  $\text{CDCl}_3$ ,  $\text{CHCl}_3 = 7.26$  ppm):  $\delta$  7.72 – 7.70 (m, 4H, TBDPS), 7.44 – 7.34 (m, 6H, TBDPS), 6.80 (s, 1H,  $\text{H}_{\text{Ar}}$ ), 6.72 (t,  $J = 2.0$  Hz, 1H,  $\text{H}_{\text{Ar}}$ ), 6.29 (s, 1H, NH), 6.11 (t,  $J = 1.7$  Hz, 1H,  $\text{H}_{\text{Ar}}$ ), 2.99 (dd,  $J = 9.7, 4.5$  Hz, 1H, H-13), 2.81 (dd,  $J = 9.6, 6.2$  Hz, 1H, H-13), 2.33 (dd,  $J = 13.4, 7.4$  Hz, 1H, H-15), 2.24 (dd,  $J = 13.4, 6.8$  Hz, 1H, H-15'), 1.49 (s, 9H, Boc), 1.46 – 1.36 (m, 1H, H-14), 1.09 (s, 9H, TBDPS), 0.79 (d,  $J = 6.5$  Hz, 3H, Me-14) ppm;

**$^{13}\text{C-NMR}$**  (400 MHz,  $\text{CDCl}_3$ ,  $\text{CDCl}_3 = 77.16$  ppm):  $\delta$  156.1 (s,  $\text{C}_{\text{Ar}}$ ), 152.6 (s, Boc), 141.6 (s,  $\text{C}_{\text{Ar}}$ ), 139.3 (s,  $\text{C}_{\text{Ar}}$ ), 135.6 (d, 4C, TBDPS), 132.9 (s, 2C, TBDPS), 130.1 (d, TBDPS), 130.0 (d, TBDPS), 127.9 (d, 2C, TBDPS), 127.9 (d, 2C, TBDPS), 115.4 (d,  $\text{C}_{\text{Ar}}$ ), 112.0 (d,  $\text{C}_{\text{Ar}}$ ), 108.0 (d,  $\text{C}_{\text{Ar}}$ ), 80.6 (s, Boc), 42.5 (t, C-15), 36.5 (d, C-14), 28.5 (q, 3C, Boc), 26.6 (q, 3C, TBDPS), 20.7 (q, Me-14), 19.6 (s, TBDPS), 17.3 (t, C-13) ppm;

$[\alpha]_{\text{D}}^{26} = -17.0$  ( $c = 1.0$ ,  $\text{CHCl}_3$ );

**HRMS-ESI**  $m/z$  for  $\text{C}_{31}\text{H}_{40}\text{INO}_3\text{SiNa}$   $[\text{M}+\text{Na}]^+$  calc. 652.1720, found 652.1724.

***tert*-Butyl (*R*)-3-((*tert*-butyldiphenylsilyl)oxy)-5-(2-methyl-3-oxopropyl)phenylcarbamate (**352**)**

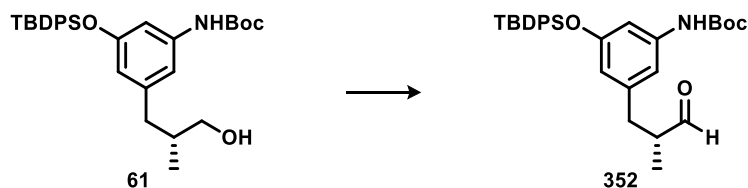

Alcohol **61** (5.63 g, 10.82 mmol, 1.0 eq.) was dissolved in CH<sub>2</sub>Cl<sub>2</sub> (150 mL) and NaHCO<sub>3</sub> (3.64 g, 43.28 mmol, 4.0 eq.) was added. The reaction was cooled to 0 °C and DMP (5.51 g, 12.99 mmol, 1.2 eq.) was added. Stirring was continued at 0 °C for 15 min. The reaction was allowed to reach room temperature and was stirred for 15 min. After the addition of an aqueous saturated NaHCO<sub>3</sub> solution, the phases were separated and the organic phase was washed with an aqueous saturated Na<sub>2</sub>S<sub>2</sub>O<sub>3</sub> solution. The combined aqueous phases were extracted with CH<sub>2</sub>Cl<sub>2</sub> (3 x 150 mL). The combined organic phases were washed with brine, dried over MgSO<sub>4</sub>, filtered and the solvent was removed under reduced pressure to furnish aldehyde **352** as a colorless foam which was directly used in the next step without further purification.

**Ethyl (*R,E*)-5-{3-[(*tert*-butoxycarbonyl)amino]-5-[(*tert*-butyldiphenylsilyl)oxy]phenyl}-4-methylpent-2-enoate (**68**)**

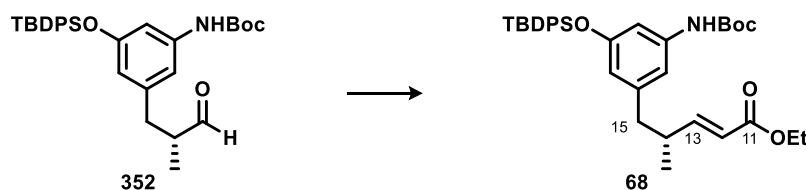

Aldehyde **352** (10.82 mmol, 1.0 eq.) was dissolved in CHCl<sub>3</sub> (80 mL) and ethyl 2-(triphenylphosphanyl)acetate (**67**, 5.65 g, 16.23 mmol, 1.5 eq.) was added. The reaction was heated to 50 °C and stirred for 12 h at this temperature. The solvent was removed under reduced pressure and the crude product was purified by flash column chromatography (PE/EtOAc = 10: → 6:1) to yield ester **68** (5.09 g, 8.66 mmol, 80 % o2s) as a colorless foam.

The analytical data are consistent with those reported in the literature.<sup>[203]</sup>

**R<sub>f</sub>** = 0.4 (PE/EtOAc = 4:1);

**<sup>1</sup>H-NMR** (400 MHz, CDCl<sub>3</sub>, CHCl<sub>3</sub> = 7.26 ppm): δ 7.71 – 7.69 (m, 4H, TBDPS), 7.43 – 7.34 (m, 6H, TBDPS), 6.81 (dd, *J* = 15.7, 6.9 Hz, 1H, H-13), 6.79 (bs, 1H, C<sub>Ar</sub>), 6.65 (s, 1H, H<sub>Ar</sub>), 6.25 (bs, 1H, NH), 6.09 (s, 1H, C<sub>Ar</sub>), 5.63 (dd, *J* = 15.7, 0.9 Hz, 1H, H-12), 4.16 (q, *J* = 7.0 Hz, 2H, OCH<sub>2</sub>CH<sub>3</sub>), 2.51 (dd, *J* = 12.6, 5.3 Hz, 1H, H-15), 2.30 – 2.18 (m, 2H, H-13, H-15'), 1.48 (s, 9H, Boc), 1.27 (t, *J* = 7.1 Hz, 3H, CH<sub>2</sub>CH<sub>3</sub>), 1.08 (s, 9H, TBDPS), 0.78 (d, *J* = 6.4 Hz, 3H, Me-14) ppm;

**<sup>13</sup>C-NMR** (400 MHz, CDCl<sub>3</sub>, CDCl<sub>3</sub> = 77.16 ppm): δ 166.9 (s, C-11), 156.1 (s, C<sub>Ar</sub>), 153.7 (d, C-13), 152.6 (s, Boc), 141.5 (s, C<sub>Ar</sub>), 139.2 (s, C<sub>Ar</sub>), 135.6 (d, 4C, TBDPS), 133.0 (s, 2C,



TBDPS), 130.0 (d, 2C TBDPS), 127.9 (d, 4C, TBDPS), 119.8 (d, C-12), 115.4 (d, C<sub>Ar</sub>), 112.1 (d, C<sub>Ar</sub>), 107.9 t, C<sub>Ar</sub>), 80.5 (s, Boc), 60.3 (t, OCH<sub>2</sub>CH<sub>3</sub>), 42.2 (t, C-15), 37.9 (d, C-14), 28.5 (q, 3C, Boc), 26.6 (q, 3C, TBDPS), 19.6 (s, TBDPS), 18.5 (q, Me-14), 14.4 (q, OCH<sub>2</sub>CH<sub>3</sub>) ppm;

$[\alpha]_{\text{D}}^{20} = -17.0$  ( $c = 1.6$ , CH<sub>2</sub>Cl<sub>2</sub>);  $[\alpha]_{\text{D}}^{20} = -18.9$ ,  $c = 1.3$ , CH<sub>2</sub>Cl<sub>2</sub>);<sup>[78]</sup>

HRMS-ESI  $m/z$  for C<sub>35</sub>H<sub>45</sub>NO<sub>5</sub>SiNa [M+Na]<sup>+</sup> calc. 610.2959, found 610.2961.

***tert*-Butyl (*R,E*)-{3-[(*tert*-butyldiphenylsilyloxy)-5-(5-hydroxy-2-methylpent-3-en-1-yl)phenyl}carbamate (**69**)**

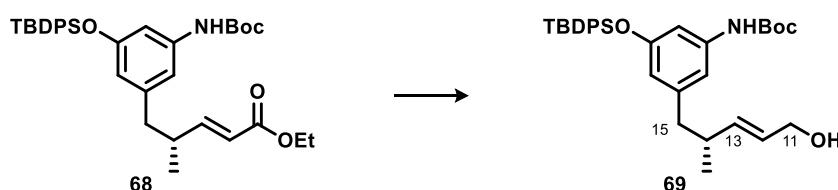

Ester **68** (6.87 g, 11.69 mmol, 1.0 eq.) was dissolved in CH<sub>2</sub>Cl<sub>2</sub> (150 mL) and cooled to  $-78$  °C. DIBAL-H (1.0 M in hexane, 29.23 mL, 29.23 mmol, 2.5 eq.) was added slowly and stirring continued at  $-78$  °C for 18 h. The mixture was diluted with EtOAc and the reaction was terminated by the addition of an aqueous saturated Rochelle's salt solution. The mixture was allowed to reach room temperature and was stirred for 15 h. The phases were separated and the aqueous phase was extracted with CH<sub>2</sub>Cl<sub>2</sub> (3 x 200 mL). The combined organic phases were washed with brine, dried over MgSO<sub>4</sub>, filtered and the solvent was removed under reduced pressure. The crude product was purified by flash column chromatography (PE/EtOAc = 10:1 → 3:1) to yield allylic alcohol **69** (4.71 g, 8.61 mmol, 65%) as a colorless foam.

The analytical data are consistent with those reported in the literature.<sup>[203]</sup>

$R_f = 0.4$  (PE/EtOAc = 4:1);

<sup>1</sup>H-NMR (400 MHz, CDCl<sub>3</sub>, CHCl<sub>3</sub> = 7.26 ppm):  $\delta$  7.72 – 7.69 (m, 4H, TBDPS), 7.43 – 7.34 (m, 6H, TBDPS), 6.91, (bs, 1H, H<sub>Ar</sub>), 6.47 (s, 1H, H<sub>Ar</sub>), 6.25 (bs, 1H, NH), 6.15 (s, 1H, H<sub>Ar</sub>), 5.50 (ddt,  $J = 15.5, 7.0, 1.2$  Hz, 1H, H-13), 5.39 (dtd,  $J = 15.5, 5.8, 0.7$  Hz, 1H, H-12), 3.99 (d,  $J = 5.8$  Hz, 2H, H-11), 2.38 (dd,  $J = 13.2, 7.4$  Hz, 1H, H-15), 2.28 (dd,  $J = 13.2, 6.6$  Hz, 1H, H-15'), 2.19 – 2.12 (m, 1H, H-14), 1.68 (bs, 1H, OH), 1.47 (s, 9H, Boc), 1.08 (s, 9H, TBDPS), 0.80 (d,  $J = 6.7$  Hz, 3H, Me-14) ppm;

<sup>13</sup>C-NMR (400 MHz, CDCl<sub>3</sub>, CDCl<sub>3</sub> = 77.16 ppm):  $\delta$  155.8 (s, C<sub>Ar</sub>), 152.9 (s, Boc), 142.4 (s, C<sub>Ar</sub>), 138.6 (s, C<sub>Ar</sub>), 138.1 (d, C-13), 135.7 (d, 4C, TBDPS), 133.1 (s, 2C, TBDPS), 130.0 (d, 2C, TBDPS), 128.0 (d, C-12), 127.9 (d, 4C, TBDPS), 115.7 (d, C<sub>Ar</sub>), 112.9 (d, C<sub>Ar</sub>), 107.7 (d, C<sub>Ar</sub>), 80.6 (s, Boc), 63.9 (t, C-11), 43.4 (t, C-15), 37.8 (d, C-14), 28.5 (q, 3C, Boc), 26.6 (q, 3C, TBDPS), 19.7 (s, TBDPS), 19.6 (q, Me-14) ppm;

$[\alpha]_{\text{D}}^{20} = -52.6$  ( $c = 1.1$ , CH<sub>2</sub>Cl<sub>2</sub>);  $[\alpha]_{\text{D}}^{20} = -1.1$ ,  $c = 1.0$ , CH<sub>2</sub>Cl<sub>2</sub>);<sup>[78]</sup>

HRMS-ESI  $m/z$  for C<sub>33</sub>H<sub>43</sub>NO<sub>4</sub>SiNa [M+Na]<sup>+</sup> calc. 568.2859, found 568.2858.

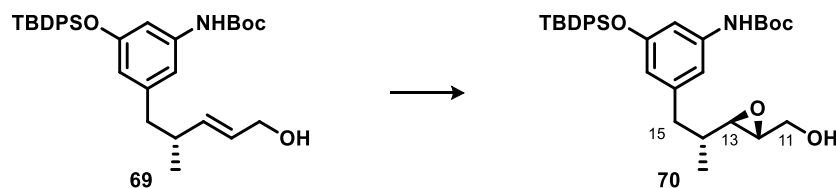
***tert*-Butyl {3-[(*tert*-butyldiphenylsilyl)oxy]-5-[(*R*)-2-[(2*R*,3*R*)-3-(hydroxymethyl)oxiran-2-yl]propyl]phenyl}carbamate (**70**)**

Freshly activated molecular sieves (4 Å) were suspended in CH<sub>2</sub>Cl<sub>2</sub> (40 mL) and D-(-)-DET (0.82 mL, 4.76 mmol, 1.3 eq.) was added. The reaction was cooled to -20 °C and Ti(O*i*-Pr)<sub>4</sub> (1.29 mL, 4.39 mmol, 1.2 eq) and *t*-BuOOH (5.0 – 6.0 M in decane, 2.93 mL, 14.65 – 17.58 mmol, 4.0 eq.) were added subsequently. Stirring was continued at this temperature for 1 h. Allylic alcohol **69** (2.0 g, 3.66 mmol, 1.0 eq.) as a solution in CH<sub>2</sub>Cl<sub>2</sub> (10 mL) was slowly added to the reaction mixture and stirring was continued at -20 °C for 42 h. The reaction was terminated by the addition of EDTE<sup>14</sup> (1.09 g, 4.61 mmol, 1.26 eq.).<sup>[85]</sup> The mixture was heated to 55 °C for 15 min and after cooling to room temperature, the mixture was diluted with aqueous NH<sub>4</sub>OH and CH<sub>2</sub>Cl<sub>2</sub>. The two clear phases were separated and the aqueous phase was extracted with CH<sub>2</sub>Cl<sub>2</sub> (3 x 20 mL). The combined organic phases were dried over MgSO<sub>4</sub>, filtered and the solvent was removed under reduced pressure. The crude product was purified by flash column chromatography (PE/EtOAc = 10:1 → 2:1) to yield epoxide **70** (1.96 g, 3.48 mmol, 95%, d.r. = 10:1) as a colorless foam.

The analytical data are consistent with those reported in the literature.<sup>[78]</sup>

**R<sub>f</sub>** = 0.3 (PE/EtOAc = 4:1);

**<sup>1</sup>H-NMR** (400 MHz, CDCl<sub>3</sub>, CHCl<sub>3</sub> = 7.26 ppm): δ 7.71 – 7.69 (m, 4H, TBDPS), 7.43 – 7.34 (m, 6H, TBDPS), 6.85 (bs, 1H, H<sub>Ar</sub>), 6.63 – 6.62 (m, 1H, H<sub>Ar</sub>), 6.29 (bs, 1H, NH), 6.12 – 6.11 (m, 1H, H<sub>Ar</sub>), 3.81 (dd, *J* = 12.6, 2.7 Hz, 1H, H-11), 3.56 (dd, *J* = 12.6, 4.2 Hz, 1H, H-11'), 2.86 – 2.84 (m, 1H, H-12), 2.70 (dd, *J* = 6.8, 2.3 Hz, 1H, H-13), 2.62 (dd, *J* = 13.4, 5.3 Hz, 1H, H-15), 2.22 (dd, *J* = 13.3, 8.9 Hz, 1H, H-15'), 1.53 – 1.15 (m, 1H, H-14), 1.48, (s, 9H, Boc), 1.08 (s, 9H, TBDPS), 0.59 (d, *J* = 6.8 Hz, 3H, Me-14) ppm;

**<sup>13</sup>C-NMR** (400 MHz, CDCl<sub>3</sub>, CDCl<sub>3</sub> = 77.16 ppm): δ 156.0 (s, C<sub>Ar</sub>), 152.7 (s, Boc), 141.4 (s, C<sub>Ar</sub>), 139.1 (s, C<sub>Ar</sub>), 135.6 (d, 4C, TBDPS), 133.0 (s, 2C, TBDPS), 130.0 (d, 2C, TBDPS), 127.9 (d, 4C, TBDPS), 115.6 (d, C<sub>Ar</sub>), 112.4 (d, C<sub>Ar</sub>), 107.9 (d, C<sub>Ar</sub>), 80.6 (s, Boc), 61.9 (t, C-11), 59.9 (d, C-13), 57.2 (d, C-12), 40.1 (t, C-15), 36.4 (d, C-14), 28.5 (q, 3C, Boc), 26.6 (q, 3C, TBDPS), 19.6 (s, TBDPS), 14.8 (q, Me-14) ppm;

**[α]<sub>D</sub><sup>20</sup>** = +5.6 (*c* = 1.2, CH<sub>2</sub>Cl<sub>2</sub>; **[α]<sub>D</sub><sup>20</sup>** = +2.2, *c* = 0.9, CH<sub>2</sub>Cl<sub>2</sub>)<sup>[78]</sup>;

**HRMS-ESI** *m/z* for C<sub>33</sub>H<sub>43</sub>NO<sub>5</sub>SiNa [M+Na]<sup>+</sup> calc. 584.2808, found 584.2807.

<sup>14</sup> *N,N,N',N'*-tetrakis(2-hydroxyethyl)ethylenediamine; 1.05 eq. relative to the amount of Ti(O*i*Pr)<sub>4</sub>.

***tert*-Butyl {3-[(*tert*-butyldiphenylsilyl)oxy]-5-[(2*R*,4*S*)-4,5-dihydroxy-2-methylpentyl]phenyl}carbamate (**71**)**

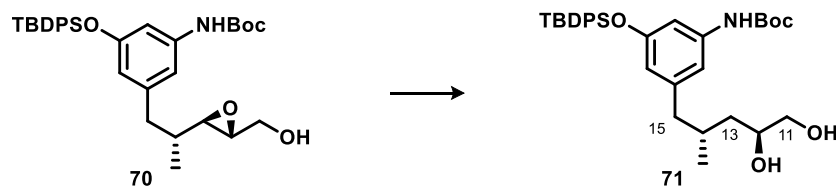

Epoxide **70** (0.56 g, 1.01 mmol, 1.0 eq.) was dissolved in Et<sub>2</sub>O (50 mL) and cooled to 0 °C. DIBAL-H (1.0 M in hexane, 5.03 mL, 5.03 mmol, 5.0 eq.) was added slowly and stirring was continued for 4.5 h at this temperature. The reaction mixture was allowed to reach room temperature and was diluted with EtOAc. An aqueous saturated Rochelle's salt solution was added and stirring was continued for 15 h. The phases were separated and the aqueous phase was extracted with EtOAc (3 x 50 mL). The combined organic phases were washed with brine, dried over MgSO<sub>4</sub>, filtered and the solvent was removed under reduced pressure. The crude product was purified by flash column chromatography (PE/EtOAc = 7:1 → 2:1) to yield diol **71** (0.35 g, 0.62 mmol, 61 %) as colorless foam.

The analytical data are consistent with those reported in the literature.<sup>[203]</sup>

**R<sub>f</sub>** = 0.2 (PE/EtOAc = 1:1);

**<sup>1</sup>H-NMR** (400 MHz, CDCl<sub>3</sub>, CHCl<sub>3</sub> = 7.26 ppm): δ 7.72 – 7.70 (m, 4H, TBDPS), 7.43 – 7.34 (m, 6H, TBDPS), 6.80 (bs, 1H, H<sub>Ar</sub>), 6.64 (s, 1H, H<sub>Ar</sub>), 6.38 (bs, 1H, NH), 6.12 (s, 1H, H<sub>Ar</sub>), 3.72 – 3.66 (m, 1H, H-12), 3.51 (dd, *J* = 11.0, 2.7 Hz, 1H, H-11), 3.30 (dd, *J* = 11.0, 7.7 Hz, 1H, H-11'), 2.32 (dd, *J* = 13.4, 6.7 Hz, 1H, H-15), 2.18 (dd, *J* = 13.4, 7.7 Hz, 1H, H-15'), 1.73 – 1.68 (m, 1H, H-14), 1.47 (s, 9H, Boc), 1.36 – 1.29 (m, 1H, H-13), 1.08 (s, 9H, TBDPS), 1.00 – 0.96 (m, 1H, H-13'), 0.68 (d, *J* = 6.6 Hz, 3H, Me-14) ppm;

**<sup>13</sup>C-NMR** (400 MHz, CDCl<sub>3</sub>, CDCl<sub>3</sub> = 77.16 ppm): δ 156.0 (s, C<sub>Ar</sub>), 152.8 (s, Boc), 142.7 (s, C<sub>Ar</sub>), 139.0 (s, C<sub>Ar</sub>), 135.7 (d, 4C, TBDPS), 133.1 (s, 2C, TBDPS), 130.0 (d, 2C, TBDPS), 127.9 (d, 4C, TBDPS), 115.6 (d, C<sub>Ar</sub>), 112.4 (d, C<sub>Ar</sub>), 107.8 (d, C<sub>Ar</sub>), 80.6 (s, Boc), 70.2 (d, C-12), 67.5 (t, C-11), 44.0 (t, C-15), 39.8 (t, C-13), 30.9 (d, C-14), 28.5 (q, 3C, Boc), 26.6 (q, 3C, TBDPS), 19.6 (s, TBDPS), 19.2 (q, Me-14) ppm;

[α]<sub>D</sub><sup>20</sup> = –9.8 (*c* = 1.0, CHCl<sub>3</sub>); [α]<sub>D</sub><sup>20</sup> = –11.0, *c* = 0.6, CH<sub>2</sub>Cl<sub>2</sub>;<sup>[78]</sup>

**HRMS-ESI** *m/z* for C<sub>33</sub>H<sub>45</sub>NO<sub>5</sub>SiNa [M+Na]<sup>+</sup> calc. 586.2965, found 586.2963.

***tert*-Butyl {3-[(2*R*,4*S*)-5-[(*tert*-butyldimethylsilyl)oxy]-4-hydroxy-2-methylpentyl]-5-[(*tert*-butyldiphenylsilyl)oxy]phenyl}carbamate (**72**)**

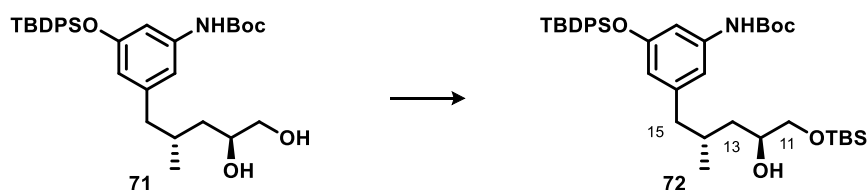

Diol **71** (1.81 g, 3.20 mmol, 1.0 eq.) was dissolved in CH<sub>2</sub>Cl<sub>2</sub> (100 mL) and cooled to 0 °C. 2,6-Lutidine (372 μL, 3.20 mmol, 1.0 eq.) was added followed by dropwise addition of

TBSOTf (736  $\mu$ L, 3.20 mmol, 1.0 eq.). The reaction was stirred at 0 °C for 30 min and was terminated by the addition of a saturated aqueous NH<sub>4</sub>Cl solution. The phases were separated and the aqueous phase was extracted with CH<sub>2</sub>Cl<sub>2</sub> (4 x 20 mL). The combined organic phases were washed with brine, dried over MgSO<sub>4</sub>, filtered and the solvent was removed under reduced pressure. The crude product was purified by flash column chromatography (PE/EtOAc = 20:1) to yield silyl ether **72** (1.67 g, 2.46 mmol, 77%, 92% brsm) as a colorless oil.

The analytical data are consistent with those reported in the literature.<sup>[203]</sup>

$R_f$  = 0.5 (PE/EtOAc = 4:1);

<sup>1</sup>H-NMR (400 MHz, CDCl<sub>3</sub>, CHCl<sub>3</sub> = 7.26 ppm):  $\delta$  7.72 – 7.70 (m, 4H, TBDPS), 7.43 – 7.34 (m, 6H, TBDPS), 6.78 (bs, 1H, H<sub>Ar</sub>), 6.66 (s, 1H, H<sub>Ar</sub>), 6.26 (bs, 1H, NH), 6.15 (s, 1H, H<sub>Ar</sub>), 3.70 – 3.64 (m 1H, H-12), 3.52 (dd,  $J$  = 9.9, 3.4 Hz, 1H, H-11), 3.31 (dd,  $J$  = 9.8, 7.6 Hz, H-11'), 2.40 (dd,  $J$  = 13.3, 6.0 Hz, 1H, H-15), 2.13 (dd,  $J$  = 13.3, 8.4 Hz, 1H, H-15'), 1.82 – 1.73 (m, 1H, H-14), 1.48 (s, 9H, Boc), 1.37 – 1.31 (m, 1H, H-13), 1.08 (s, 9H, TBDPS), 0.99 – 0.92 (m, 1H, H-13'), 0.90 (s, 9H, TBDPS), 0.67 (d,  $J$  = 6.6 Hz, 3H, Me-14), 0.07 (s, 6H, TBDPS) ppm;

<sup>13</sup>C-NMR (400 MHz, CDCl<sub>3</sub>, CDCl<sub>3</sub> = 77.16 ppm):  $\delta$  155.9 (s, C<sub>Ar</sub>), 152.6 (s, Boc), 142.9 (s, C<sub>Ar</sub>), 139.0 (s, C<sub>Ar</sub>), 135.7 (d, 4C, TBDPS), 133.1 (s, 2C, TBDPS), 129.9 (d, 2C, TBDPS), 127.9 (d, 4C, TBDPS), 115.6 (d, C<sub>Ar</sub>), 112.3 (d, C<sub>Ar</sub>), 107.6 (d, C<sub>Ar</sub>), 80.4 (s, Boc), 69.7 (d, C-12), 68.0 (t, C-11), 44.3 (t, C-15), 39.6 (t, C-13), 31.0 (d, C-14), 28.5 (q, 3C, Boc), 26.6 (q, 3C, TBDPS), 26.0 (q, 3C, TBS), 19.6 (s, TBDPS), 19.0 (q, Me-14), 18.4 (s, TBS), -5.2 (q, 2C, TBS) ppm;

$[\alpha]_D^{20}$  = -2.0 ( $c$  = 1.4, CH<sub>2</sub>Cl<sub>2</sub>;  $[\alpha]_D^{20}$  = -4.7,  $c$  = 1.8, CH<sub>2</sub>Cl<sub>2</sub>)<sup>[78]</sup>;

HRMS-ESI  $m/z$  for C<sub>39</sub>H<sub>59</sub>NO<sub>5</sub>Si<sub>2</sub>Na [M+Na]<sup>+</sup> calc. 700.3830, found 700.3834.

***tert*-Butyl {3-[(2*R*,4*S*)-5-[(*tert*-butyldimethylsilyl)oxy]-4-methoxy-2-methylpentyl]-5-[(*tert*-butyldiphenylsilyl)oxy]phenyl}carbamate (mole4)**

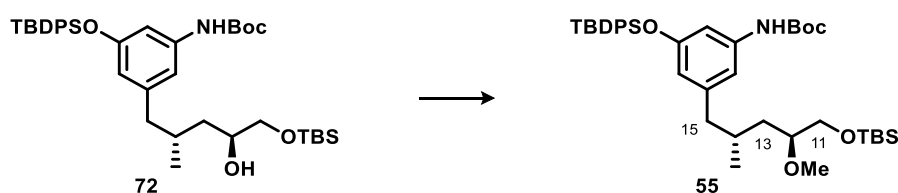

Alcohol **72** (1.6 g, 2.36 mmol, 1.0 eq.) was dissolved in dry CH<sub>2</sub>Cl<sub>2</sub> (70 mL) and proton-sponge<sup>®</sup> (1.77 g, 8.26 mmol, 3.5 eq.) was added to the reaction, subsequently Me<sub>3</sub>O<sup>+</sup>BF<sub>4</sub><sup>-</sup> (0.87 g, 5.90 mmol, 2.5 eq.) was added and stirring was continued at room temperature for 1 h. The reaction was terminated by the addition of water and the phases were separated. The organic phase was washed with a 1 M CuSO<sub>4</sub> solution (1 x 50 mL) and a 1 M KHSO<sub>4</sub> solution (2 x 50 mL). The aqueous phases were extracted with CH<sub>2</sub>Cl<sub>2</sub> (1 x 50 mL). The combined organic phases were washed with brine, dried over MgSO<sub>4</sub>, filtered and the solvent was removed under reduced pressure. The crude product was purified by flash column chromatography (PE/EtOAc = 20:1 → 15:1) to yield methyl ether **55** (1.39 g, 2.01 mmol, 85%) as a colorless foam.

The analytical data are consistent with those reported in the literature.<sup>[203]</sup>

$R_f$  = 0.6 (PE/EtOAc = 4:1);

**<sup>1</sup>H-NMR** (400 MHz, CDCl<sub>3</sub>, CHCl<sub>3</sub> = 7.26 ppm): δ 7.72 – 7.69 (m, 4H, TBDPS), 7.41 – 7.33 (m, 6H, TBDPS), 6.75 (bs, 1H, H<sub>Ar</sub>), 6.67 (s, 1H, H<sub>Ar</sub>), 6.24 (bs, 1H, NH), 6.14 (s, 1H, H<sub>Ar</sub>), 3.58 (dd, *J* = 10.5, 5.8 Hz, 1H, H-11), 3.46 (dd, *J* = 10.5, 4.8 Hz, H-11'), 3.36 (s, 3H, OMe), 3.25 – 3.19 (m 1H, H-12), 2.42 (dd, *J* = 13.3, 5.5 Hz, 1H, H-15), 2.06 (dd, *J* = 13.3, 9.3 Hz, 1H, H-15'), 1.75 – 1.66 (m, 1H, H-14), 1.48 (s, 9H, Boc), 1.36 – 1.32 (m, 1H, H-13), 1.08 (s, 9H, TBDPS), 0.89 (s, 9H, TBDPS), 0.86 – 0.83 (m, 1H, H-13'), 0.62 (d, *J* = 6.6 Hz, 3H, Me-14), 0.05 (s, 6H, TBDPS) ppm;

**<sup>13</sup>C-NMR** (400 MHz, CDCl<sub>3</sub>, CDCl<sub>3</sub> = 77.16 ppm): δ 155.9 (s, C<sub>Ar</sub>), 152.6 (s, Boc), 143.1 (s, C<sub>Ar</sub>), 139.0 (s, C<sub>Ar</sub>), 135.7 (d, 4C, TBDPS), 133.1 (s, 2C, TBDPS), 129.9 (d, 2C, TBDPS), 127.9 (d, 4C, TBDPS), 115.6 (d, C<sub>Ar</sub>), 112.3 (d, C<sub>Ar</sub>), 107.6 (d, C<sub>Ar</sub>), 80.5 (s, Boc), 80.0 (d, C-12), 66.1 (t, C-11), 58.2 (q, OMe), 44.4 (t, C-15), 39.2 (t, C-13), 31.2 (d, C-14), 28.5 (q, 3C, Boc), 26.6 (q, 3C, TBDPS), 26.1 (q, 3C, TBS), 19.6 (s, TBDPS), 19.0 (q, Me-14), 18.4 (s, TBS), -5.2 (q, 2C, TBS) ppm;

$[\alpha]_{\text{D}}^{20} = -7.3$  (*c* = 1.0, CHCl<sub>3</sub>);  $[\alpha]_{\text{D}}^{20} = -7.4$ , *c* = 1.0, CHCl<sub>3</sub>)<sup>[75]</sup>;

**HRMS-ESI** *m/z* for C<sub>39</sub>H<sub>59</sub>NO<sub>5</sub>Si<sub>2</sub>Na [M+Na]<sup>+</sup> calc. 586.2965, found 586.2964.

***tert*-Butyl {3-[(*tert*-butyldiphenylsilyloxy)-5-[(2*R*,4*S*)-5-hydroxy-4-methoxy-2-methylpentyl]phenyl]carbamate (62)**

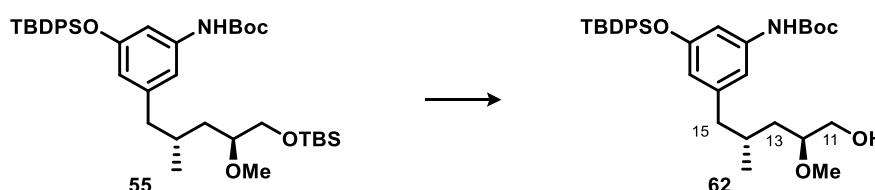

Silyl ether **55** (299 mg, 0.432 mmol, 1.0 eq.) was dissolved in CH<sub>2</sub>Cl<sub>2</sub>/MeCN (1:1, 30 mL) and LiBF<sub>4</sub> (122 mg, 1.30 mmol, 3.0 eq.) was added.<sup>15</sup> The mixture was stirred at room temperature for 48 h. The reaction was then terminated by the addition of water and the aqueous phase was extracted with CH<sub>2</sub>Cl<sub>2</sub> (3 x 10 mL). The combined organic phases were washed with brine, dried over MgSO<sub>4</sub>, filtered and the solvent was removed under reduced pressure. The crude product was purified by flash column chromatography (PE/EtOAc = 10:1 → 2:1) affording the corresponding primary alcohol **62** (184 mg, 0.318 mmol, 74%, 88% brsm) as a colorless foam.

The analytical data are consistent with those reported in the literature.<sup>[75]</sup>

**R<sub>f</sub>** = 0.6 (PE/EtOAc = 1:1);

**<sup>1</sup>H-NMR** (400 MHz, CDCl<sub>3</sub>, CHCl<sub>3</sub> = 7.26 ppm): δ 7.70 – 7.69 (m, 4H, TBDPS), 7.41 – 7.34 (m, 6H, TBDPS), 6.77 (bs, 1H, H<sub>Ar</sub>), 6.68 (s, 1H, H<sub>Ar</sub>), 6.32 (bs, 1H, NH), 6.11 (s, 1H, H<sub>Ar</sub>), 3.60 (dd, *J* = 11.5, 3.5 Hz, 1H, H-11), 3.38 (dd, *J* = 11.5, 5.9 Hz, 1H, H-11'), 3.31 (s, 3H, OMe), 3.27 – 3.23 (m, 1H, H-12), 2.39 (dd, *J* = 13.3, 5.7 Hz, 1H, H-15), 2.07 (dd, *J* = 13.3, 8.6 Hz, 1H, H-15'), 1.64 – 1.59 (m, 1H, H-14), 1.54 – 1.46 (m, 1H, H-13), 1.48 (s, 9H, Boc), 1.07 (s, 9H, TBDPS), 1.05 – 1.00 (m, 1H, H-13'), 0.66 (d, *J* = 6.6 Hz, 3H, Me-14) ppm;

<sup>15</sup> LiBF<sub>4</sub> was dried under vacuum for 2 h at 155 °C and stored in a glovebox for further use.

$^{13}\text{C-NMR}$  (400 MHz,  $\text{CDCl}_3$ ,  $\text{CDCl}_3 = 77.16$  ppm):  $\delta$  156.0 (s,  $\text{C}_{\text{Ar}}$ ), 152.7 (s, Boc), 142.7 (s,  $\text{C}_{\text{Ar}}$ ), 139.1 (s,  $\text{C}_{\text{Ar}}$ ), 135.6 (d, 4C, TBDPS), 133.1 (s, 2C, TBDPS), 129.9 (d, 2C, TBDPS), 127.9 (d, 4C, TBDPS), 115.5 (d,  $\text{C}_{\text{Ar}}$ ), 112.3 (d,  $\text{C}_{\text{Ar}}$ ), 107.7 (d,  $\text{C}_{\text{Ar}}$ ), 80.5 (s, Boc), 79.6 (d, C-12), 64.3 (t, C-11), 57.1 (q, OMe), 44.0 (t, C-15), 38.0 (t, C-13), 31.4 (d, C-14), 28.5 (q, 3C, Boc), 26.6 (q, 3C, TBDPS), 19.6 (s, TBDPS), 19.5 (q, Me-14) ppm;

$[\alpha]_{\text{D}}^{20} = +2.9$  ( $c = 3.0$ ,  $\text{CH}_2\text{Cl}_2$ );

**HRMS-ESI**  $m/z$  for  $\text{C}_{34}\text{H}_{47}\text{NO}_5\text{SiNa}$   $[\text{M}+\text{Na}]^+$  calc. 600.3121, found 600.3123.

***tert*-Butyl (3-((*tert*-butyldiphenylsilyl)oxy)-5-((2*R*,4*S*)-4-methoxy-2-methyl-5-oxopentyl)phenyl)carbamate (**73**)**

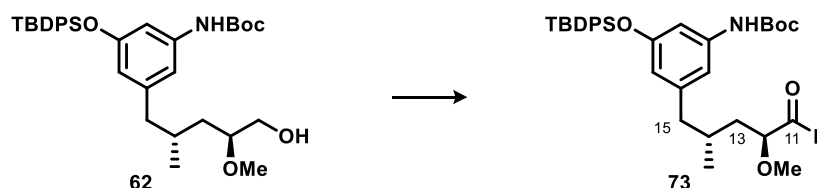

Alcohol **62** (72 mg, 0.125 mmol, 1.0 eq.) was dissolved in  $\text{CH}_2\text{Cl}_2$  (15 mL) and cooled to  $0^\circ\text{C}$ . Then  $\text{NaHCO}_3$  (17 mg, 0.202 mmol, 1.7 eq.) and subsequently DMP (90 mg, 0.202 mmol, 1.7 eq.) was added. The ice-bath was removed and the mixture was stirred at room temperature for 1 h. The reaction was terminated by the addition of an aqueous saturated  $\text{Na}_2\text{SO}_3$  solution. The phases were separated and the aqueous phase was extracted with  $\text{CH}_2\text{Cl}_2$  (3 x 10 mL). The combined organic phases were dried over  $\text{MgSO}_4$ , filtered and the solvent was removed under reduced pressure. The crude product was purified by flash column chromatography (PE/EtOAc = 10:1  $\rightarrow$  4:1) to yield aldehyde **73** (55 mg, 0.097 mmol, 78%) as a colorless foam.

$R_f = 0.8$  (PE/EtOAc = 1:1);

$^1\text{H-NMR}$  (400 MHz,  $\text{CDCl}_3$ ,  $\text{CHCl}_3 = 7.26$  ppm):  $\delta$  9.55 (s, 1H, CHO), 7.71 – 7.69 (m, 4H, TBDPS), 7.41 – 7.33 (m, 6H, TBDPS), 6.75 (bs, 1H,  $\text{H}_{\text{Ar}}$ ), 6.68 (s, 1H,  $\text{H}_{\text{Ar}}$ ), 6.28 (bs, 1H, NH), 6.10 (s, 1H,  $\text{H}_{\text{Ar}}$ ), 3.55 – 3.52 (m, 1H, H-12), 3.36 (s, 3H, OMe), 2.34 (dd,  $J = 13.3$ , 6.3 Hz, 1H, H-15), 2.15 (dd,  $J = 13.3$ , 8.2 Hz, 1H, H-15'), 1.77 – 1.73 (m, 1H, H-14), 1.48 (s, 10H, Boc, H-13), 1.08 (s, 10H, TBDPS, H-13'), 0.67 (d,  $J = 6.6$  Hz, 3H, Me-14) ppm.

***tert*-Butyl (3-((*tert*-butyldiphenylsilyl)oxy)-5-((2*R*,4*S*,5*R*,6*S*)-5-hydroxy-4-methoxy-2,6-dimethyloct-7-en-1-yl)phenyl)carbamate (**39**)**

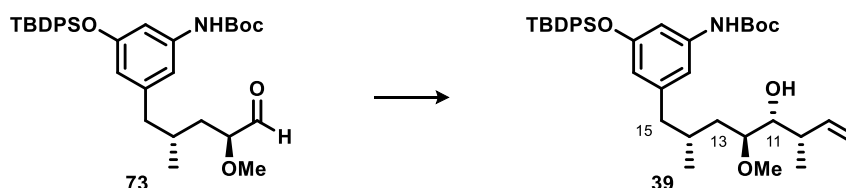

(*S,S*)-Diisopropyl (*Z*)-crotylboronate (**76**, 404 mg, 1.36 mmol, 4.1 eq.) was dissolved in PhMe (5 mL) and molecular sieves (4 Å, 120 mg) were added. The mixture was stirred for 20 min and then cooled to  $-78^\circ\text{C}$ . Aldehyde **73** (190 mg, 0.331 mmol, 1.0 eq.) as a solution in PhMe

(8 mL) was added slowly to the reaction. Stirring was continued at  $-78\text{ }^{\circ}\text{C}$  for 24 h. The reaction was terminated by the addition of an aqueous 1 M NaOH. The mixture was warmed to room temperature and stirred for 1 h before it was filtered through Celite<sup>®</sup> and rinsed with Et<sub>2</sub>O. The phases were separated and the aqueous phase was extracted with Et<sub>2</sub>O (3 x 10 mL). The combined organic phases were dried over MgSO<sub>4</sub>, filtered and the solvent was removed under reduced pressure. The crude product was purified by flash column chromatography (PE/EtOAc = 10:1  $\rightarrow$  6:1) to yield homoallylic alcohol **39** (199 mg, 0.316 mmol, 96%, *d.r.* = 8:1) as a pale red oil.

The analytical data are consistent with those reported in the literature.<sup>[75]</sup>

$R_f$  = 0.6 (PE/EtOAc = 2:1);

<sup>1</sup>H-NMR (400 MHz, CDCl<sub>3</sub>, CHCl<sub>3</sub> = 7.26 ppm):  $\delta$  7.72 – 7.70 (m, 4H, TBDPS), 7.41 – 7.34 (m, 6H, TBDPS), 6.77 (s, 1H, H<sub>Ar</sub>), 6.66 (s, 1H, H<sub>Ar</sub>), 6.28 (s, 1H, NH), 6.16 (s, 1H, H<sub>Ar</sub>), 5.65 – 5.56 (m, 1H, H-9), 5.02 (d,  $J$  = 10.4 Hz, 1H, H-8), 4.99 (d,  $J$  = 3.0 Hz, 1H, H-8'), 3.58 (dd,  $J$  = 8.9, 2.9 Hz, 1H, H-11), 3.29 (s, 3H, OMe), 3.19 (dt,  $J$  = 10.1, 2.5 Hz, 1H, H-12), 2.42 (dd,  $J$  = 13.3, 5.5 Hz, 1H, H-15), 2.24 – 2.18 (m, 1H, H-10), 2.06 (dd,  $J$  = 13.2, 9.1 Hz, 1H, H-15'), 1.53 – 1.51 (m, 1H, H-14), 1.56 – 1.52 (m, 1H, H-13), 1.48 (s, 9H, Boc), 1.13 (d,  $J$  = 6.6 Hz, 3H, Me-10), 1.08 (s, 9H, TBDPS), 1.07 – 1.03 (m, 1H, H-13'), 0.57 (d,  $J$  = 6.5 Hz, 3H, Me-14) ppm;

<sup>13</sup>C-NMR (400 MHz, CDCl<sub>3</sub>, CDCl<sub>3</sub> = 77.16 ppm):  $\delta$  155.9 (s, C<sub>Ar</sub>), 152.7 (s, Boc), 143.1 (s, C<sub>Ar</sub>), 140.1 (d, C-9), 139.0 (s, C<sub>Ar</sub>), 135.6 (d, 4C, TBDPS), 133.1 (s, 2C, TBDPS), 129.9 (d, 2C, TBDPS), 127.9 (d, 4C, TBDPS), 115.6 (t, C-8), 115.3 (d, C<sub>Ar</sub>), 112.3 (d, C<sub>Ar</sub>), 107.6 (d, C<sub>Ar</sub>), 80.4 (s, Boc), 80.2 (d, C-12), 73.5 (d, C-11), 57.1 (q, OMe), 44.6 (t, C-15), 40.5 (d, C-10), 34.7 (t, C-13), 30.9 (d, C-14), 28.5 (q, 3C, Boc), 26.6 (q, 3C, TBDPS), 19.6 (s, TBDPS), 18.5 (q, Me-14), 17.5 (q, Me-14) ppm;

$[\alpha]_D^{20}$  =  $-11.0$  ( $c$  = 1.8, CH<sub>2</sub>Cl<sub>2</sub>; lit.  $[\alpha]_D^{20}$  =  $-17.8$ ,  $c$  = 1.0, CHCl<sub>3</sub>)<sup>[75]</sup>;

HRMS-ESI  $m/z$  for C<sub>38</sub>H<sub>53</sub>NO<sub>5</sub>SiNa [M+Na]<sup>+</sup> calc. 654.3591, found 654.3591.

***tert*-Butyl (3-((*tert*-butyldiphenylsilyl)oxy)-5-((2*R*,4*S*,5*R*,6*S*)-5-hydroxy-4-methoxy-2,6-dimethylnon-7-yn-1-yl)phenyl)carbamate (**98**)**

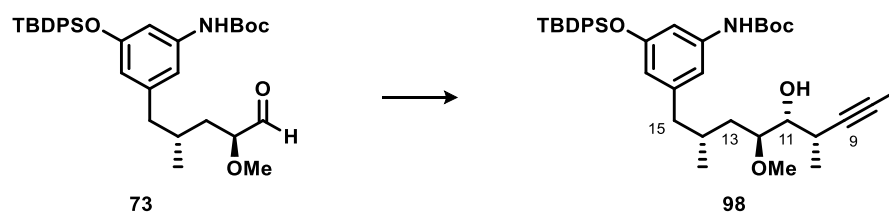

Molecular sieves (4 Å, powder, 150 mg) were suspended in CH<sub>2</sub>Cl<sub>2</sub> and cooled to  $-78\text{ }^{\circ}\text{C}$ . Aldehyde **73** (126 mg, 0.219 mmol, 1.0 eq.) was dried via azeotropic removal of water (concentrated from benzene (3 x 3 mL)), dissolved in CH<sub>2</sub>Cl<sub>2</sub> (3 mL) and added to the reaction flask. Allenyl stannane **100** (120 mg, 0.328 mmol, 1.5 eq.) was added to the reaction mixture and stirred for 5 min. Then, BF<sub>3</sub>·OEt<sub>2</sub> (40 μl, 0.328 mmol, 1.5 eq.) was added slowly to the yellow solution which turned orange immediately. Stirring was continued at  $-78\text{ }^{\circ}\text{C}$  for 3 h. The reaction was terminated by the addition of a saturated aqueous NaHCO<sub>3</sub> solution and the mixture was allowed to reach room temperature. The phases were separated and the

aqueous phase was extracted with  $\text{CH}_2\text{Cl}_2$  (3 x 10 mL). The combined organic phases were dried over  $\text{MgSO}_4$ , filtered and the solvent was removed under reduced pressure. The crude product was purified by flash column chromatography (PE/EtOAc = 15:1  $\rightarrow$  5:1). However, remaining stannane impurities could only be removed by further flash column chromatography (PE/EtOAc = 15:1  $\rightarrow$  5:1) three times to give alkyne **98** (31 mg, 0.048 mmol, 22%, *d.r.* = 4:1) as a colorless oil.

$R_f$  = 0.5 (PE/EtOAc = 4:1);

$^1\text{H-NMR}$  (400 MHz,  $\text{CDCl}_3$ ,  $\text{CHCl}_3$  = 7.26 ppm):  $\delta$  7.72 – 7.69 (m, 4H, TBDPS), 7.41 – 7.33 (m, 6H, TBDPS) 6.77 (bs, 1H,  $\text{H}_{\text{Ar}}$ ), 6.65 (s, 1H,  $\text{H}_{\text{Ar}}$ ), 6.23 (bs, 1H, NH), 6.16 (s, 1H,  $\text{H}_{\text{Ar}}$ ), 3.66 – 3.64 (m, 1H, H-11), 3.51 (dt,  $J$  = 10.5, 2.5 Hz, 1H, H-12), 3.33 (s, 3H, OMe), 2.42 (dd,  $J$  = 13.3, 5.5 Hz, 1H, H-15), 2.34 – 2.31 (m, 1H, H-10), 2.08 (dd,  $J$  = 13.2, 9.2 Hz, 1H, H-15'), 1.76 (d,  $J$  = 2.3 Hz, 3H, Me-8), 1.74 – 1.72 (m, 1H, H-14), 1.47 (s, 10H, Boc, H-13), 1.25 (d,  $J$  = 6.7 Hz, 3H, Me-10), 1.08 (s, 10H, TBDPS, H-13'), 0.64 (d,  $J$  = 6.5 Hz, 3H, Me-14) ppm;

$^{13}\text{C-NMR}$  (400 MHz,  $\text{CDCl}_3$ ,  $\text{CDCl}_3$  = 77.16 ppm):  $\delta$  155.9 (s,  $\text{C}_{\text{Ar}}$ ), 152.7 (s, Boc), 143.2 (s,  $\text{C}_{\text{Ar}}$ ), 139.0 (s,  $\text{C}_{\text{Ar}}$ ), 135.7 (d, 4C, TBDPS), 133.1 (s, 2C, TBDPS), 129.9 (d, 2C, TBDPS), 127.9 (d, 4C, TBDPS), 115.6 (d,  $\text{C}_{\text{Ar}}$ ), 112.3 (d,  $\text{C}_{\text{Ar}}$ ), 107.6 (d,  $\text{C}_{\text{Ar}}$ ), 80.4 (s, Boc), 80.1 (d, C-12), 79.9 (s, C-9), 78.0 (s, C-8), 73.5 (d, C-11), 57.1 (q, OMe), 44.6 (t, C-15), 34.8 (t, C-13), 30.9 (d, C-14), 28.8 (d, C-10), 28.5 (q, 3C, Boc), 26.6 (q, 3C, TBDPS), 19.6 (s, TBDPS), 18.6 (q, Me-10), 18.4 (q, Me-14), 3.6 (q, Me-8) ppm;

$[\alpha]_{\text{D}}^{25}$  = -22.9 ( $c$  = 1.0,  $\text{CH}_2\text{Cl}_2$ );

**HRMS-ESI**  $m/z$  for  $\text{C}_{39}\text{H}_{53}\text{NO}_5\text{SiNa}$   $[\text{M}+\text{Na}]^+$  calc. 666.3591, found 666.3591.

### Mosher Ester Analysis

#### (*S*)-MTPA-Ester ((*S*)-109)

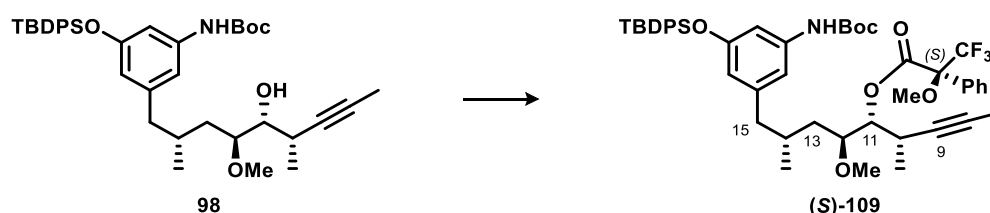

Alkyne **98** (13 mg, 20.2  $\mu\text{mol}$ , 1.0 eq.) was dissolved in  $\text{CH}_2\text{Cl}_2$  (1.5 mL) and  $\text{Et}_3\text{N}$  (5 mg, 50.5  $\mu\text{mol}$ , 2.5 eq.), DMAP (0.1 mg, 1.0  $\mu\text{mol}$ , 0.05 eq.) and (*R*)-(-)-MTPA-Cl (10 mg, 40.4  $\mu\text{mol}$ , 2.0 eq.) were added subsequently. The mixture was stirred at room temperature overnight, directly applied on silica gel and purified by flash column chromatography (PE/EtOAc = 20:1  $\rightarrow$  10:1) to yield (*S*)-**109** (5.4 mg, 6.28  $\mu\text{mol}$ , 33% brsm) as a colorless oil.

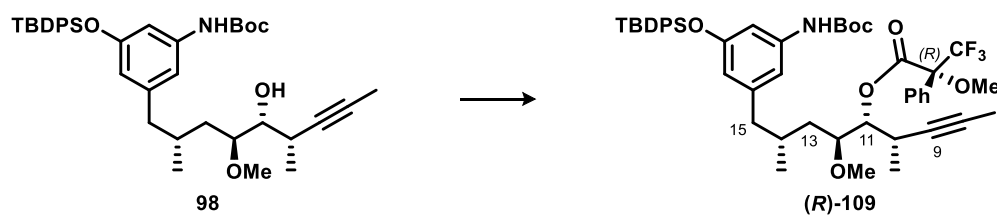

**(R)-MTPA-Ester ((R)-109)**

Alkyne **98** (13 mg, 20.2  $\mu\text{mol}$ , 1.0 eq.) was dissolved in  $\text{CH}_2\text{Cl}_2$  (1.5 mL) and  $\text{Et}_3\text{N}$  (5.1 mg, 50.5  $\mu\text{mol}$ , 2.5 eq.), DMAP (0.1 mg, 1.0  $\mu\text{mol}$ , 0.05 eq.) and (*S*)-(-)-MTPA-Cl (10 mg, 40.4  $\mu\text{mol}$ , 2.0 eq.) were added subsequently. The mixture was stirred at room temperature overnight, directly applied on silica gel and purified by flash column chromatography (PE/EtOAc = 20:1  $\rightarrow$  10:1) to yield (*R*)-**109** (6.6 mg, 7.72  $\mu\text{mol}$ , 38% brsm) as a colorless oil.

**Table 2:**  $^1\text{H-NMR}$  data for the determination of the absolute configuration at C-11 of alkyne **98**.

| Proton No. | $\delta$ ( <i>S</i> )- <b>109</b> [ppm] | $\delta$ ( <i>R</i> )- <b>109</b> [ppm] | $\Delta \delta^{\text{SR}}$ ( $= \delta_{\text{S}} - \delta_{\text{R}}$ ) |
|------------|---|---|---|
| 15a        | 2.25                                    | 2.29                                    | - 0.04  |
| 15b        | 1.95                                    | 2.09                                    | - 0.14  |
| 14         | 1.64                                    | 1.72                                    | - 0.07  |
| Me-14      | 0.55                                    | 0.64                                    | - 0.10  |
| 13a        | 1.22                                    | 1.43                                    | - 0.21  |
| 13b        | 0.99                                    | 1.05                                    | - 0.06  |
| 12         | 3.58                                    | 3.66                                    | - 0.08  |
| OMe        | 3.30                                    | 3.35                                    | - 0.05  |
| 11         | 5.28                                    | 5.31                                    | - 0.04  |
| 10         | 2.59                                    | 2.44                                    | + 0.16  |
| Me-10      | 1.18                                    | 0.99                                    | + 0.18  |
| Me-8       | 1.76                                    | 1.76                                    | + 0.01  |

***tert*-Butyl (3-((*tert*-butyldiphenylsilyl)oxy)-5-((2*R*,4*S*,5*R*,6*S*,*E*)-5-hydroxy-8-iodo-4-methoxy-2,6-dimethylnon-7-en-1-yl)phenyl)carbamate (**97**)**

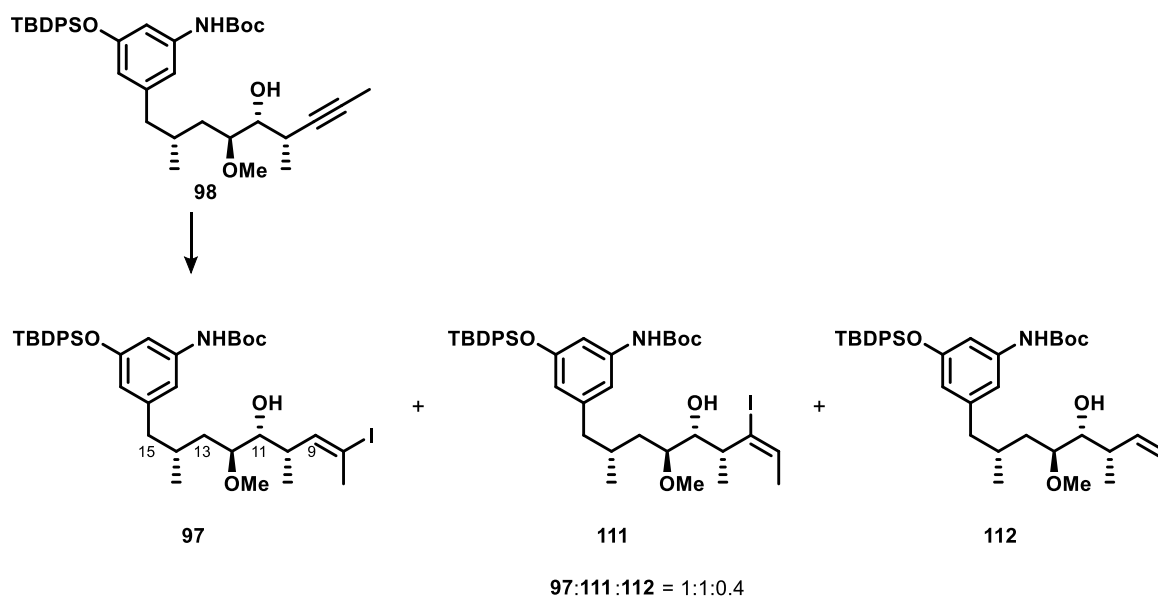

A round bottom flask was charged with alkyne **98** (8.0 mg, 12.42  $\mu\text{mol}$ , 1.0 eq.) and the atmosphere was changed by evacuating and backfilling with argon (3x).  $\text{Cp}_2\text{ZrHCl}$  (8.2 mg, 31.05  $\mu\text{mol}$ , 2.5 eq.) was added in a glovebox. THF (1 mL) was added and the reaction was stirred at 55  $^\circ\text{C}$  for 1 h in the absence of light. The reaction was allowed to reach room temperature and stirred for 10 minutes. The reaction was cooled to 0  $^\circ\text{C}$  and  $\text{I}_2$  (6.3 mg, 24.84  $\mu\text{mol}$ , 2.0 eq.) was added as a solution in THF (300  $\mu\text{L}$ ). Stirring was continued for 1 h at this temperature, before the reaction was terminated by the addition of a saturated aqueous  $\text{Na}_2\text{S}_2\text{O}_3$  solution. The phases were separated and the aqueous phase was extracted with EtOAc (2 x 5 mL). The combined organic phases were washed with water, brine, dried over  $\text{MgSO}_4$ , filtered and the solvent was removed under reduced pressure. The crude product was purified by flash column chromatography (PE/EtOAc = 12:1  $\rightarrow$  4:1) to furnish a colorless oil (3.8 mg) that is an inseparable mixture of vinyl iodide **97** and its regioisomer **111** as well as the alkene **112** (ratio 1:1:0.4).

$R_f = 0.6$  (PE/EtOAc = 2:1);

$^1\text{H-NMR}^{16}$  (400 MHz,  $\text{CDCl}_3$ ,  $\text{CHCl}_3 = 7.26$  ppm):  $\delta$  7.72 – 7.69 (m, 9H, TBDPS), 7.43 – 7.33 (m, 14H, TBDPS), 6.77 (bs, 2H,  $\text{H}_{\text{Ar}}$ ), 6.65 – 6.64 (m, 2H,  $\text{H}_{\text{Ar}}$ ), 6.24 – 6.22 (m, 2H, NH), 6.15 – 6.13 (m, 2H,  $\text{H}_{\text{Ar}}$ ), 5.92 (dd,  $J = 10.5, 1.4$  Hz, 1H,  $\text{H-9}_{\text{Product}}$ ), 5.43 – 5.37 (m, 1H,  $\text{H-8}_{\text{Isomer}}$ ), 5.14 – 5.09 (m, 2H, integrates to 0.78,  $\text{H-8}_{\text{Alkene}}$ ), 3.62 – 3.56 (m, 2H, H-11), 3.33 (s, 3H, integrates to 0.49,  $\text{OMe}_{\text{Alkene}}$ ), 3.30 (s, 3H,  $\text{OMe}_{\text{Product}}$ ), 3.29 (s, 3H,  $\text{OMe}_{\text{Isomer}}$ ), 3.24 – 3.22 (m, 1H, integrates to 0.33,  $\text{H-12}_{\text{Alkene}}$ ), 3.16 – 3.09 (m, 2H, H-12), 2.43 – 2.37 (m, 3H, H-15,  $\text{H-10}_{\text{Isomer}}$ ), 2.32 (d,  $J = 1.4$  Hz, 3H,  $\text{Me-8}_{\text{Product}}$ ), 2.11 – 2.01 (m, 3H, H-15',  $\text{H-10}_{\text{Product}}$ ), 1.76 (d,  $J = 2.4$  Hz, 3H, integrates to 0.82,  $\text{Me-8}_{\text{Alkene}}$ ), 1.74 – 1.66 (m, 2H, H-10), 1.57 – 1.55 (m, 5H,  $\text{M-8}_{\text{Isomer}}$ , H-13), 1.48 (s, 19H, Boc), 1.08 (bs, 24H, TBDPS, Me-10), 0.99 – 0.92 (m,

<sup>16</sup> Signals that could be clearly assigned to the respective compound were marked by corresponding indices. For the sake of clarity, no indexing was used when the signals of the three products overlap.

2H, H-13'), 0.64 (d,  $J = 6.5$  Hz, 3H, integrates to 1.0, Me-14<sub>Alkene</sub>), 0.57 (d,  $J = 6.6$  Hz, 3H, Me-14<sub>Product</sub>), 0.53 (d,  $J = 6.5$  Hz, Me-14<sub>Isomer</sub>) ppm;

**HRMS-ESI**  $m/z$  for C<sub>39</sub>H<sub>54</sub>INO<sub>5</sub>SiNa [M+Na]<sup>+</sup> calc. 794.2714, found 794.2715.

**(3*S*,4*R*,5*S*,7*R*)-8-(3-((*tert*-Butoxycarbonyl)amino)-5-((*tert*-butyldiphenylsilyl)oxy)phenyl)-5-methoxy-3,7-dimethyloct-1-en-4-yl ((3*S*,4*S*)-7-((*tert*-butyldimethylsilyl)oxy)-4-methoxy-2-methylhept-1-en-3-yl) succinate (**90**)**

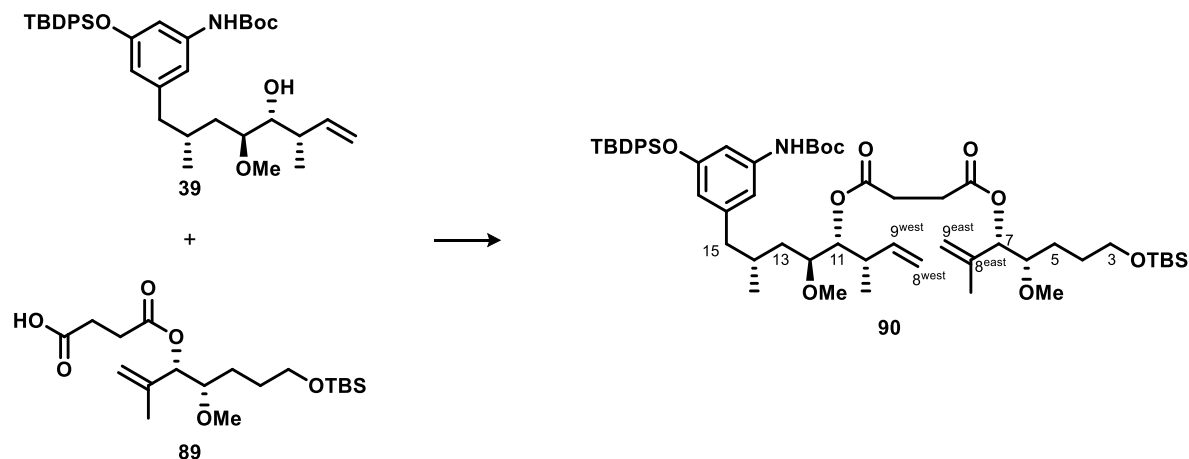

Crude acid **89** (9.8 mg, 0.025 mmol, 1.1 eq.) was dissolved in CH<sub>2</sub>Cl<sub>2</sub> (2 mL). DCC (14.2 mg, 0.069 mmol, 3.0 eq.) and DMAP (5.6 mg, 0.046 mmol, 2.0 eq.) was added and the mixture was stirred at room temperature for 30 min. Then, homoallylic alcohol **39** (14.5 mg, 0.023 mmol, 1.0 eq.) was added as a solution in CH<sub>2</sub>Cl<sub>2</sub> (300 μL) and stirring was continued at room temperature for 18 h. The reaction was diluted with MTBE, filtered and the solvent was removed under reduced pressure. The crude product was purified by flash column chromatography (PE/EtOAc = 10:1 → 6:1) to yield a mixture of tethered diene **90** and homoallylic alcohol **39**. After repetitive (3x) purification by flash column chromatography (PE/EtOAc = 10:1 → 6:1) tethered diene **90** (4.8 mg, 4.80 μmol, 21%) was obtained as a colourless oil.

$R_f = 0.7$  (PE/EtOAc = 2:1);

**<sup>1</sup>H-NMR** (400 MHz, CDCl<sub>3</sub>, CHCl<sub>3</sub> = 7.26 ppm):  $\delta$  7.71 – 7.68 (m, 4H, TBDPS), 7.41 – 7.33 (m, 6H, TBDPS), 6.76 (s, 1H, H<sub>Ar</sub>), 6.67 (s, 1H, H<sub>Ar</sub>), 6.29 (s, 1H, NH), 6.14 (s, 1H, H<sub>Ar</sub>), 5.66 – 5.57 (m, 1H, H-9<sup>west</sup>), 5.21 (d,  $J = 6.0$  Hz, 1H, H-7), 5.08 – 4.94 (m, 5H, H-8<sup>west</sup>, H-9<sup>east</sup>, H-11), 3.64 – 3.57 (m, 2H, H-3), 3.42 (s, 3H, OMe-4), 3.38 – 3.34 (m, 1H, H-6), 3.25 (s, 3H, OMe-12), 3.26 – 3.23 (m, 1H, H-12), 2.72 – 2.61 (m, 4H, -OOCCH<sub>2</sub>CH<sub>2</sub>COO-), 2.46 (dd,  $J = 13.2, 4.8$  Hz, H-15), 2.35 – 2.31 (m, 1H, H-10), 1.98 (dd,  $J = 13.3, 10.0$  Hz, 1H, H-15'), 1.75 (s, 3H, Me-8), 1.70 – 1.65 (m, 1H, H-14), 1.65 – 1.62 (m, 1H, H-4), 1.55 – 1.50 (m, 2H, H-4', H-5), 1.49 – 1.44 (m, 11H, Boc, H-5', H-13), 1.07 (s, 9H, TBDPS), 0.98 (d,  $J = 6.6$  Hz, 3H, Me-10), 0.88 (s, 9H, TBS), 0.86 – 0.81 (m, 1H, H-13'), 0.51 (d,  $J = 6.5$  Hz, 3H, Me-14), 0.04 (s, 6H, TBS) ppm;

**HRMS-ESI**  $m/z$  for C<sub>57</sub>H<sub>87</sub>NO<sub>10</sub>Si<sub>2</sub>Na [M+Na]<sup>+</sup> calc. 1024.5767, found 1024.5760.

## 5.4 Second Generation Synthesis

### 5.4.1 Western Fragment

#### Methyl (*R*)-3-(benzyloxy)-2-methylpropanoate (**124**)

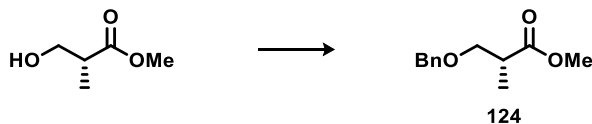

Benzyl 2,2,2-trichloroacetimidate (3.64 g, 14.41 mmol, 1.1 eq.) was added to a solution of (*R*)-Roche ester (1.55 g, 13.11 mmol, 1.0 eq.) in cyclohexane/CH<sub>2</sub>Cl<sub>2</sub> (90 mL, 2:1) at 0 °C. TfOH (57 μL, 0.66 mmol, 0.05 eq.) was then added dropwise, resulting in the formation of a white suspension. The solution was then stirred at this temperature for 2 h before being warmed to room temperature and stirred for 16 h. A second addition of benzyl 2,2,2-trichloroacetimidate (1.65 g, 6.55 mmol, 0.5 eq.) and TfOH (28 μL, 0.33 mmol, 0.025 eq.) was then made and the mixture was stirred for further 18 h. The solution was filtered through Celite<sup>®</sup>, washed with petroleum ether and then concentrated under reduced pressure. The residue was then dissolved in EtOAc and sequentially washed with an aqueous saturated NaHCO<sub>3</sub> solution and brine, dried over MgSO<sub>4</sub>, filtered and the solvent was removed under reduced pressure. The crude product was purified by automated flash column chromatography (PE/EtOAc 0-100%) to furnish benzyl ether **124** (2.46 g, 11.79 mmol, 90%) as a colorless oil. The analytical data are consistent with those reported in the literature.<sup>[205]</sup>

$R_f = 0.6$  (PE/EtOAc = 2:1);

<sup>1</sup>H-NMR (400 MHz, CDCl<sub>3</sub>, CHCl<sub>3</sub> = 7.26 ppm): δ 7.34 – 7.26 (m, 5H, Bn), 4.53 (s, 2H, Bn), 3.69 (s, 3H, OMe), 3.66 (dd, *J* = 9.0, 7.4 Hz, 1H, H-3), 3.49 (dd, *J* = 9.1, 5.9 Hz, 1H, H-3'), 2.82 – 2.77 (m, 1H, H-2), 1.19 (d, *J* = 7.2 Hz, 3H, Me) ppm;

HRMS-ESI *m/z* for C<sub>12</sub>H<sub>16</sub>O<sub>3</sub>Na [M+Na]<sup>+</sup> calc. 231.0997 found 231.0996.

#### (*S*)-4-Benzyl-3-((*R*)-3-(benzyloxy)-2-methylpropanoyl)oxazolidin-2-one (**127**)

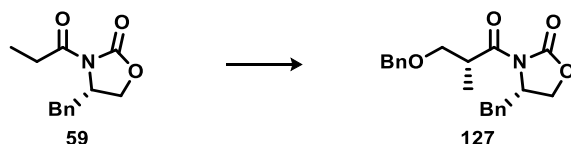

(*S*)-4-Benzyl-3-propionyl-oxazolidin-2-one (**59**, 753 mg, 3.23 mmol, 1.0 eq.) was dissolved in CH<sub>2</sub>Cl<sub>2</sub> (15 mL) and cooled to 0 °C. TiCl<sub>4</sub> (420 μL, 3.40 mmol, 1.05 eq.) was added followed by the addition of DIPEA (600 μL, 3.55 mmol, 1.1 eq.). The red mixture was stirred for 1 h at this temperature before BOMCl (890 μL, 6.46 mmol, 2.0 eq.) was added dropwise and stirring was continued for 6 h at 0 °C. The reaction was terminated by the addition of phosphate buffer (pH 7). The phases were separated and the aqueous phase was extracted with CH<sub>2</sub>Cl<sub>2</sub> (3 x 10 mL). The combined organic phases were dried over MgSO<sub>4</sub>, filtered and the solvent was removed under reduced pressure. The crude product was purified by flash column

chromatography (PE/EtOAc = 4:1  $\rightarrow$  2:1) to furnish oxazolidinone **127** (602 mg, 2.58 mmol, 80%) as a colorless oil.

The analytical data are consistent with those reported in the literature.<sup>[206]</sup>

$R_f$  = 0.3 (PE/EtOAc = 4:1);

$^1\text{H-NMR}$  (400 MHz,  $\text{CDCl}_3$ ,  $\text{CHCl}_3$  = 7.26 ppm):  $\delta$  7.38 – 7.19 (m, 10H, Bn), 4.74 – 4.69 (m, 1H, H-4), 4.56 (s, 2H, OBn), 4.22 – 4.14 (m, 3H, H-5 and CHCO), 3.81 (dd,  $J$  = 9.1, 7.9 Hz, 1H,  $\text{CH}_2\text{OBn}$ ), 3.59 (dd,  $J$  = 9.1, 5.3 Hz, 1H,  $\text{CH}_2\text{OBn}$ ), 3.24 (dd,  $J$  = 13.5, 3.1 Hz, 1H, Bn), 2.73 (dd,  $J$  = 13.5, 9.3 Hz, 1H, Bn), 1.20 (d,  $J$  = 6.9 Hz, 3H, Me) ppm;

$[\alpha]_D^{21}$  = + 42.0 ( $c$  = 1.1,  $\text{CH}_2\text{Cl}_2$ ; lit.  $[\alpha]_D^{20}$  = + 50.4,  $c$  = 1.55,  $\text{CH}_2\text{Cl}_2$ )<sup>[206]</sup>;

**HRMS-ESI**  $m/z$  for  $\text{C}_{21}\text{H}_{23}\text{NO}_4\text{Na}$   $[\text{M}+\text{Na}]^+$  calc. 376.1525 found 376.1521.

### (S)-3-(Benzyloxy)-2-methylpropan-1-ol (**125**)

#### Method A:

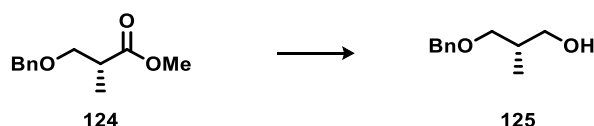

$\text{LiBH}_4$  (2 M in THF, 8.82 mL, 17.64 mmol, 3.0 eq.) was slowly added to a solution of methyl ester **124** (1.23 g, 5.88 mmol, 1.0 eq.) in THF (50 mL) at 0 °C. MeOH (0.79 mL, 19.36 mmol, 3.3 eq.) was then added and the mixture was stirred for 15 min at this temperature and for 1.5 h at room temperature. The reaction was terminated by the addition of an aqueous 1 M NaOH solution. The phases were separated and the aqueous phase was extracted with EtOAc (3 x 20 mL). The combined organic phases were dried over  $\text{MgSO}_4$ , filtered and the solvent was removed under reduced pressure. The crude product was purified by flash column chromatography (PE/EtOAc = 9:1  $\rightarrow$  4:1) to furnish alcohol **125** (868 mg, 4.82 mmol, 82%) as a colorless oil.

#### Method B:

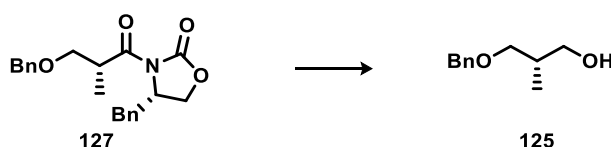

Oxazolidinone **127** (602 mg, 2.58 mmol, 1.0 eq.) was dissolved in MeOH/THF (12 mL, 3% MeOH) and cooled to 0 °C.  $\text{LiBH}_4$  (2 M in THF, 2.58 mL, 5.16 mmol, 2.0 eq.) was added dropwise and stirring was continued for 30 min at 0 °C. The mixture was then stirred 1.5 h at room temperature and the reaction was terminated by the addition of an aqueous 1 M NaOH solution. The phases were separated and the aqueous phase was extracted with  $\text{Et}_2\text{O}$  (3 x 15 mL). The combined organic phases were washed with brine and dried over  $\text{MgSO}_4$ , filtered and the solvent was removed under reduced pressure. The crude product was purified

by flash column chromatography (PE/EtOAc = 4:1) to afford alcohol **125** (302 mg, 1.68 mmol, 65%) as a colorless oil.

The analytical data are consistent with those reported in the literature.<sup>[207]</sup>

$R_f = 0.2$  (PE/EtOAc = 4:1);

$^1\text{H-NMR}$  (400 MHz,  $\text{CDCl}_3$ ,  $\text{CHCl}_3 = 7.26$  ppm):  $\delta$  7.37 – 7.25 (m, 5H, Bn), 4.52 (s, 2H, Bn), 3.66 – 3.59 (m, 2H, H-1), 3.54 (dd,  $J = 9.3, 5.2$  Hz, 1H, H-3), 3.43 (dd,  $J = 8.8, 8.1$  Hz, 1H, H-3'), 2.41 (bs, 1H, OH), 2.12 – 2.03 (m, 1H, H-2), 0.89 (d,  $J = 7.0$  Hz, 3H, Me) ppm;

$[\alpha]_D^{21} = -16.2$  ( $c = 1.0$ ,  $\text{CH}_2\text{Cl}_2$ ; lit.  $[\alpha]_D^{20} = -13.9$ ,  $c = 1.0$ ,  $\text{CHCl}_3$ )<sup>[207]</sup>;

**HRMS-ESI**  $m/z$  for  $\text{C}_{11}\text{H}_{16}\text{O}_2\text{Na}$   $[\text{M}+\text{Na}]^+$  calc. 203.1048 found 203.1047.

### (*R*)-((3-Iodo-2-methylpropoxy)methyl)benzene (**128**)

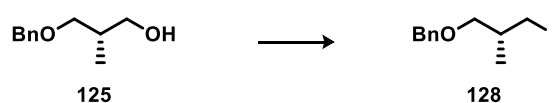

Imidazole (307 mg, 4.52 mmol, 1.5 eq.) and iodine (994 mg, 3.92 mmol, 1.3 eq.) were sequentially added to a solution of  $\text{PPh}_3$  (948 mg, 3.62 mmol, 1.2 eq.) in  $\text{CH}_2\text{Cl}_2$  (15 mL) at room temperature. A solution of alcohol **125** (543 mg, 3.01 mmol, 1.0 eq.) in  $\text{CH}_2\text{Cl}_2$  (4 mL) was added to the fine suspension and stirring was continued for 2 h. The solvent was removed under reduced pressure and the resulting solid residue was purified by flash column chromatography (dry-loading, PE/EtOAc = 4:1) to afford iodide **128** (831 mg, 2.86 mmol, 95%) as a colorless oil.

The analytical data are consistent with those reported in the literature.<sup>[208]</sup>

$R_f = 0.7$  (PE/EtOAc = 2:1);

$^1\text{H-NMR}$  (400 MHz,  $\text{CDCl}_3$ ,  $\text{CHCl}_3 = 7.26$  ppm):  $\delta$  7.38 – 7.24 (m, 5H, Bn), 4.52 (s, 2H, Bn), 3.41 – 3.29 (m, 4H, H-1, H-3), 1.83 – 1.75 (m, 1H, H-2), 0.99 (d,  $J = 6.7$  Hz, 3H, Me) ppm;

$[\alpha]_D^{21} = -10.2$  ( $c = 1.0$ ,  $\text{CH}_2\text{Cl}_2$ ; lit.  $[\alpha]_D^{20} = -8.7$ ,  $c = 1.0$ ,  $\text{CH}_2\text{Cl}_2$ )<sup>[208]</sup>;

**GCMS** [EI] calc. 290.0168 found 290.1.

### (2*S*,4*S*)-5-(Benzyloxy)-*N*-((1*R*,2*R*)-1-hydroxy-1-phenylpropan-2-yl)-2-methoxy-*N*,4-dimethylpentanamide (**129**)

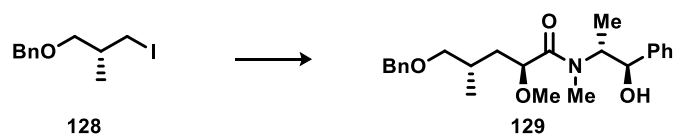

A flask was charged with  $\text{LiCl}$  (365 mg, 8.53 mmol, 11.0 eq.) and flame-dried. THF (8 mL) and DIPA (0.41 mL, 2.95 mmol, 3.8 eq.) were added and the suspension was cooled to  $-78$  °C.  $n\text{-BuLi}$  (2.5 M in hexanes, 1.09 mL, 2.73 mmol, 3.5 eq.) was added slowly and the resulting mixture was warmed to  $0$  °C for 3-5 min and was then cooled to  $-78$  °C again. Myer's auxiliary **65** (331 mg, 1.39 mmol, 1.8 eq.) was added and the solution was stirred at  $-78$  °C for 1 h, at  $0$  °C for 15 min and at room temperature for 5 min. The mixture was then again cooled to  $0$  °C and iodide **128** (225 mg, 0.78 mmol, 1.0 eq.) was added as a solution in

3 mL THF. The reaction was stirred at 0 °C for 18 h and terminated with a half-concentrated aqueous NH<sub>4</sub>Cl solution. The phases were separated and the aqueous phase was extracted with EtOAc (3 x 20mL). The combined organic phases were dried over MgSO<sub>4</sub>, filtered through a silica plug and rinsed with EtOAc (60 mL). All volatiles were removed under reduced pressure and the resulting oil was used in the following step without further purification.

**(2*S*,4*S*)-5-(Benzyloxy)-2-methoxy-4-methylpentan-1-ol (130)**

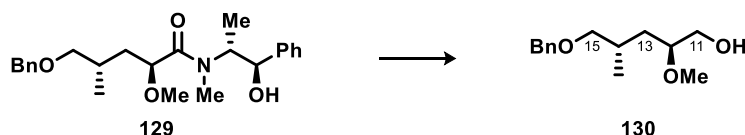

A flame-dried flask was charged with THF (6mL) and DIPA (0.46 mL, 3.26 mmol, 4.2 eq.). The solution was cooled to -78 °C and *n*-BuLi (2.5 M in hexanes, 1.2 mL, 3.02 mmol, 3.9 eq.) was added slowly. The solution was warmed to 0 °C and stirred for 10 min. Then borane-ammonia complex (106 mg, 3.10 mmol, 4.0 eq.) was added carefully in portions and stirring was continued for 15 min at 0 °C and 15 min at room temperature. The suspension was then cooled to 0 °C and crude amide **129** (0.78 mmol, 1.0 eq.) was added as a solution in THF (3 mL). The reaction was allowed to reach room temperature and was stirred for 2 h. The reaction was terminated by the addition of an aqueous saturated NH<sub>4</sub>Cl solution. The phases were separated and the aqueous phase was extracted with ether (3 x 20 mL). The combined organic phases were washed with an aqueous saturated NaHCO<sub>3</sub> solution and brine, dried over MgSO<sub>4</sub>, filtered and the solvent was removed under reduced pressure. The crude product was purified by flash column chromatography (PE/EtOAc = 4:1 → 1:1) to furnish alcohol **130** (122 mg, 0.51 mmol, 66% o2s, *d.r.* = 15:1) as a colorless oil.

The analytical data are consistent with those reported in the literature.<sup>[101]</sup>

**R<sub>f</sub>** = 0.5 (100% EtOAc);

**<sup>1</sup>H-NMR** (400 MHz, CDCl<sub>3</sub>, CHCl<sub>3</sub> = 7.26 ppm): δ 7.37 – 7.25 (m, 5H, Bn), 4.50 (s, 2H, Bn), 3.72 – 3.69 (m, 1H, H-11), 3.51 – 3.45 (m, 1H, H-11'), 3.41 – 3.59 (m, 1H, H-12), 3.39 (s, 3H, OMe), 3.48 – 3.27 (m, 2H, H-15), 2.07 (bs, 1H, OH), 2.00 – 1.89 (m, 1H, H-14), 1.73 (ddd, *J* = 14.2, 7.6, 5.5 Hz, 1H, H-13), 1.22 (ddd, *J* = 14.1, 8.2, 5.3 Hz, 1H, H-13'), 0.98 (d, *J* = 6.7 Hz, 3H, Me) ppm;

**<sup>13</sup>C-NMR** (400 MHz, CDCl<sub>3</sub>, CDCl<sub>3</sub> = 77.16 ppm): δ 138.7 (s, Bn), 128.5 (d, 2C, Bn), 127.7 (d, 2C, Bn), 127.7 (d, Bn), 79.6 (d, C-12), 76.1 (t, C-11), 73.1 (t, Bn), 64.2 (t, C-15), 57.2 (q, OMe), 35.1 (t, C-13), 30.2 (d, C-14), 17.7 (q, Me-14) ppm;

[α]<sub>D</sub><sup>21</sup> = +9.0 (*c* = 1.1, CH<sub>2</sub>Cl<sub>2</sub>; lit. [α]<sub>D</sub><sup>20</sup> = +6.2, *c* = 0.6, CHCl<sub>3</sub>)<sup>[101]</sup>;

**HRMS-ESI** *m/z* for C<sub>14</sub>H<sub>22</sub>O<sub>3</sub>Na [M+Na]<sup>+</sup> calc. 261.1467 found 261.1463.

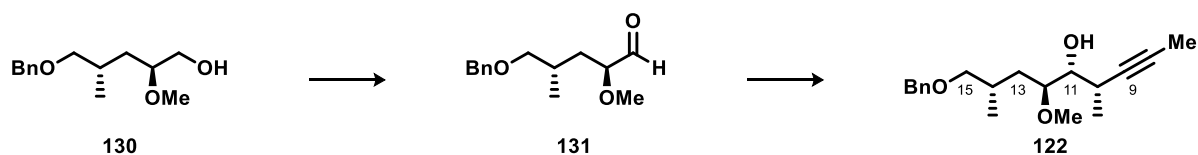
**(4S,5R,6S,8S)-9-(Benzyloxy)-6-methoxy-4,8-dimethylnon-2-yn-5-ol (122)**

Oxalyl chloride (329  $\mu\text{L}$ , 3.84 mmol, 2.0 eq.) was dissolved in  $\text{CH}_2\text{Cl}_2$  (7 mL) and cooled to  $-78^\circ\text{C}$  and DMSO (545  $\mu\text{L}$ , 7.69 mmol, 4.0 eq.) was added dropwise. The resulting solution was stirred for 15 min. Alcohol **130** (458 mg, 1.92 mmol, 1.0 eq.) was slowly added as a solution in 7 mL  $\text{CH}_2\text{Cl}_2$ . Stirring was continued for 1.5 h before  $\text{Et}_3\text{N}$  (1.6 mL, 11.53 mmol, 6.0 eq.) was added dropwise. The mixture was allowed to reach room temperature and was diluted with  $\text{CH}_2\text{Cl}_2$ . The reaction was terminated by the addition of an aqueous saturated  $\text{NH}_4\text{Cl}$  solution. The phases were separated and the aqueous phase was extracted with  $\text{CH}_2\text{Cl}_2$  (3 x 15 mL). The combined organic phases were washed with brine, dried over  $\text{MgSO}_4$ , filtered and the solvent was removed under reduced pressure. The crude product was purified by flash column chromatography (PE/EtOAc = 10:1) to yield aldehyde **131** (353 mg, 1.50 mmol, 78%) as a colorless oil which was used in the next step without further analysis.  $R_f$  = 0.6 (PE/EtOAc = 2:1; vanillin stain: green spot)

The Marshall propargylation was carried out in parallel in three batches of equal size. Allenyl stannane **100** (267 mg, 0.747 mmol, 1.5 eq.) was dissolved in  $\text{CH}_2\text{Cl}_2$  (1 mL) cooled to  $-78^\circ\text{C}$ . Freshly prepared aldehyde **131** (117.6 mg, 0.50 mmol, 1.0 eq.) was dissolved in  $\text{CH}_2\text{Cl}_2$  (1 mL) and transferred to the reaction flask.  $\text{BF}_3\cdot\text{OEt}_2$  (70  $\mu\text{L}$ , 0.55 mmol, 1.1 eq.) was added, resulting in a turbid highly viscous mixture.<sup>17</sup> Stirring was continued for 30 min at  $-78^\circ\text{C}$  before the reaction was terminated by the addition of an aqueous saturated  $\text{NaHCO}_3$  solution and the mixture was allowed to reach room temperature. The three batches were combined, the phases were separated and the aqueous phase was extracted with  $\text{CH}_2\text{Cl}_2$  (3 x 5 mL). The combined organic phases were dried over  $\text{MgSO}_4$ , filtered and the solvent was removed under reduced pressure. The crude product was purified by flash column chromatography (PE/EtOAc = 10:1  $\rightarrow$  8:1) to furnish alkyne **122** (214 mg, 0.703 mmol, 47%, *d.r.* = 6:1) as a single diastereomer. The product was a colorless oil.

The analytical data are consistent with those reported in the literature.<sup>[101]</sup>

$R_f$  = 0.4 (PE/EtOAc = 2:1; vanillin stain: deep blue spot);

$^1\text{H-NMR}$  (500 MHz,  $\text{CDCl}_3$ ,  $\text{CHCl}_3$  = 7.26 ppm):  $\delta$  7.34 – 7.26 (m, 5H, Bn), 4.51 (s, 2H, Bn), 3.69 (dd,  $J$  = 8.9, 3.4 Hz, 1H, H-11), 3.58 (dt,  $J$  = 10.3, 2.8 Hz, 1H, H-12), 3.39 (s, 3H, OMe), 3.34 (dd,  $J$  = 9.0, 6.1 Hz, 1H, H-15), 3.27 (dd,  $J$  = 9.0, 6.8 Hz, 1H, H-15), 2.41 – 2.35 (m, 1H, H-10), 2.29 (bs, 1H, OH), 2.06 – 2.01 (m, 1H, H-14), 1.78 (d,  $J$  = 2.2 Hz, 3H, Me-8), 1.66 (ddd,  $J$  = 13.9, 10.4, 3.6 Hz, 1H, H-13), 1.27 (d,  $J$  = 6.7 Hz, 3H, Me-10), 1.24 – 1.19 (m, 1H, H-13'), 0.98 (d,  $J$  = 6.6 Hz, 3H, Me-14) ppm;

$^{13}\text{C-NMR}$  (500 MHz,  $\text{CDCl}_3$ ,  $\text{CDCl}_3$  = 77.16 ppm):  $\delta$  138.9 (s, Bn), 128.4 (d, 2C, Bn), 127.7 (d, 2C, Bn), 127.5 (d, Bn), 80.1 (s, C-9), 80.0 (d, C-12), 78.0 (s, C-8), 76.6 (t, C-15), 73.5 (d,

<sup>17</sup> Sometimes the mixture tended to freeze, in which case a few drops of  $\text{CH}_2\text{Cl}_2$  were added to prevent freezing.



C-11), 73.1 (t, Bn), 57.2 (q, OMe), 31.6 (t, C-13), 29.9 (d, C-14), 28.9 (d, C-10), 18.5 (q, Me-10), 16.8 (q, Me-14), 3.6 (q, Me-8) ppm;

$[\alpha]_D^{23} = -30.9$  ( $c = 1.1$ ,  $\text{CHCl}_3$ ; lit.  $[\alpha]_D^{20} = -29.7$ ,  $c = 0.5$ ,  $\text{CHCl}_3$ )<sup>[101]</sup>;

**HRMS-ESI**  $m/z$  for  $\text{C}_{15}\text{H}_{28}\text{O}_3\text{Na}$   $[\text{M}+\text{Na}]^+$  calc. 327.1936 found 327.1935.

**(((4*S*,5*R*,6*S*,8*S*)-9-(Benzyloxy)-6-methoxy-4,8-dimethylnon-2-yn-5-yl)oxy)(*tert*-butyl)dimethylsilane (134)**

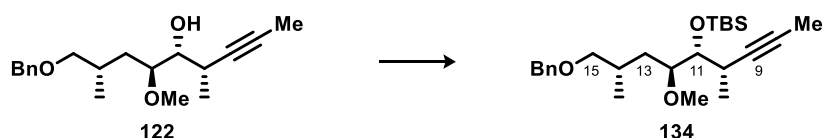

Homopropargylic alcohol **122** (214 mg, 0.703 mmol, 1.0 eq.) was dissolved in  $\text{CH}_2\text{Cl}_2$  (7 mL) and cooled to 0 °C. 2,6-Lutidine (244  $\mu\text{L}$ , 2.11 mmol, 3.0 eq.) was added, followed by dropwise addition of TBSOTf (323  $\mu\text{L}$ , 1.41 mmol, 2.0 eq.). Stirring was continued at 0 °C for 20 minutes and 15 minutes at room temperature. The reaction was terminated by the addition of a saturated aqueous  $\text{NH}_4\text{Cl}$  solution (5 mL). The phases were separated and the aqueous phase was extracted with  $\text{CH}_2\text{Cl}_2$  (3 x 5 mL). The combined organic phases were washed with brine, dried over  $\text{MgSO}_4$ , filtered and the solvent was removed under reduced pressure. The crude product was purified by flash column chromatography (PE/EtOAc = 10:1  $\rightarrow$  6:1) to yield silyl ether **134** (291 mg, 0.696 mmol, 99%) as a colorless oil.

$R_f = 0.6$  (PE/EtOAc = 6:1);

**$^1\text{H-NMR}$**  (400 MHz,  $\text{CDCl}_3$ ,  $\text{CHCl}_3 = 7.26$  ppm):  $\delta$  7.35 – 7.23 (m, 5H, Bn), 4.50 (s, 2H, Bn), 3.65 (dd,  $J = 8.7, 1.8$  Hz, 1H, H-11), 3.56 (dt,  $J = 10.3, 1.9$  Hz, 1H, H-12), 3.39 – 3.36 (m, 1H, H-15), 3.34 (s, 3H, OMe), 3.28 – 3.22 (m, 1H, H-15'), 2.39 – 2.31 (m, 1H, H-10), 2.05 – 1.96 (m, 1H, H-14), 1.77 (d,  $J = 2.4$  Hz, 3H, Me-8), 1.68 – 1.61 (m, 1H, H-13), 1.18 (d,  $J = 6.9$  Hz, 3H, Me-10), 1.18 – 1.11 (m, 1H, H-13'), 0.97 (d,  $J = 6.6$  Hz, 3H, Me-14), 0.89 (s, 9H, TBS), 0.08 (s, 3H, TBS), 0.05 (s, 3H, TBS) ppm;

**$^{13}\text{C-NMR}$**  (400 MHz,  $\text{CDCl}_3$ ,  $\text{CDCl}_3 = 77.16$  ppm):  $\delta$  139.1 (s, Bn), 128.4 (d, 2C, Bn), 127.6 (d, 2C, Bn), 127.4 (d, Bn), 81.6 (s, C-9), 81.5 (d, C-12), 77.8 (s, C-8), 76.8 (t, C-15), 76.3 (d, C-11), 73.0 (t, Bn), 57.4 (q, OMe), 33.2 (t, C-13), 30.3 (d, C-14), 29.9 (d, C-10), 26.3 (q, 3C, TBS), 18.8 (q, Me-10), 18.6 (s, TBS), 17.0 (q, Me-14), 3.6 (q, Me-8), -3.7 (q, TBS), -4.6 (q, TBS) ppm;

$[\alpha]_D^{23} = -27.5$  ( $c = 0.9$ ,  $\text{CH}_2\text{Cl}_2$ );

**HRMS-ESI**  $m/z$  for  $\text{C}_{25}\text{H}_{42}\text{O}_3\text{SiNa}$   $[\text{M}+\text{Na}]^+$  calc. 441.2801, found 441.2799.

**(((4*S*,5*R*,6*S*,8*S*,*E*)-9-(Benzyloxy)-2-iodo-6-methoxy-4,8-dimethylnon-2-en-5-yl)oxy)(*tert*-butyl)dimethylsilane (**135**)**

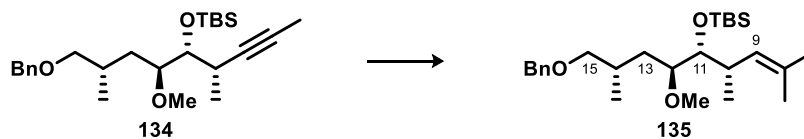

A flask was charged with alkyne **134** (79 mg, 0.189 mmol, 1.0 eq.) and the atmosphere was exchanged three times with argon. In a glovebox, Cp<sub>2</sub>ZrHCl (121 mg, 0.472 mmol, 2.5 eq.) was added. THF (2 mL) was added and the reaction was stirred at 50 °C for 1 h in the absence of light. The reaction was allowed to reach room temperature and stirred for another 10 minutes. The reaction was cooled to -78 °C and I<sub>2</sub> (95 mg, 0.377 mmol, 2.0 eq.) was added as a solution in THF (1 mL). Stirring was continued for 1 h at this temperature, before the reaction was terminated by the addition of a saturated aqueous Na<sub>2</sub>S<sub>2</sub>O<sub>3</sub> solution. The phases were separated and the aqueous phase was extracted with EtOAc (3 x 10 mL). The combined organic phases were washed with water, brine, dried over MgSO<sub>4</sub>, filtered and the solvent was removed under reduced pressure. The crude product was purified by flash column chromatography (PE/EtOAc = 10:1) to furnish vinyl iodide **135** (85 mg, 0.155 mmol, 82%) as a colorless oil which was dried by azeotropic removal of water with benzene (2 x 3 mL).

$R_f = 0.7$  (PE/EtOAc = 10:1);

**<sup>1</sup>H-NMR** (400 MHz, CDCl<sub>3</sub>, CHCl<sub>3</sub> = 7.26 ppm):  $\delta$  7.34 – 7.26 (m, 5H, Bn), 5.97 (dq,  $J = 1.5, 10.5$  Hz, 1H, H-9), 4.51 (s, 2H, Bn), 3.54 (dd,  $J = 2.0, 7.8$  Hz, 1H, H-11), 3.37 – 3.32 (m, 1H, H-15), 3.32 (s, 3H, OMe), 3.28 – 3.24 (m, 1H, H-15'), 3.14 (dt,  $J = 1.9, 10.5$  Hz, 1H, H-12), 2.52 – 2.41 (m, 1H, H-10), 2.36 (d,  $J = 1.4$  Hz, 3H, Me-8), 2.01 – 1.93 (m, 1H, H-14), 1.69 – 1.59 (m, 1H, H-13), 1.09 – 0.97 (m, 1H, H-13'), 1.01 (d,  $J = 6.7$  Hz, 3H, Me-10), 0.93 (d,  $J = 6.6$  Hz, 3H, Me-14), 0.90 (s, 9H, TBS), 0.07 (s, 3H, TBS), 0.05 (s, 3H, TBS) ppm;

**<sup>13</sup>C-NMR** (400 MHz, CDCl<sub>3</sub>, CDCl<sub>3</sub> = 77.16 ppm):  $\delta$  144.4 (d, C-9), 139.0 (s, Bn), 128.4 (d, 2C, Bn), 127.6 (d, 2C, Bn), 127.5 (d, Bn), 93.6 (s, C-8), 81.7 (d, C-12), 76.7 (t, C-15), 76.2 (d, C-11), 73.0 (t, Bn), 57.8 (q, OMe), 39.3 (d, C-10), 33.7 (t, C-13), 30.2 (d, C-14), 28.1 (q, Me-8), 26.3 (q, 3C, TBS), 18.6 (s, TBS), 17.4 (q, Me-10), 17.1 (q, Me-14), -3.7 (q, TBS), -4.6 (q, TBS) ppm;

$[\alpha]_D^{22} = -35.0$  ( $c = 0.4$ , CH<sub>2</sub>Cl<sub>2</sub>);

**HRMS-ESI**  $m/z$  for C<sub>25</sub>H<sub>43</sub>IO<sub>3</sub>SiNa [M+Na]<sup>+</sup> calc. 569.1924, found 569.1920.

**(5*R*,6*S*,10*S*,*E*)-5-((1*S*,3*S*)-4-(Benzyloxy)-1-methoxy-3-methylbutyl)-10-methoxy-2,2,3,3,6,8,15,15,16,16-decamethyl-4,14-dioxa-3,15-disilaheptadec-7-en-9-ol (142)**

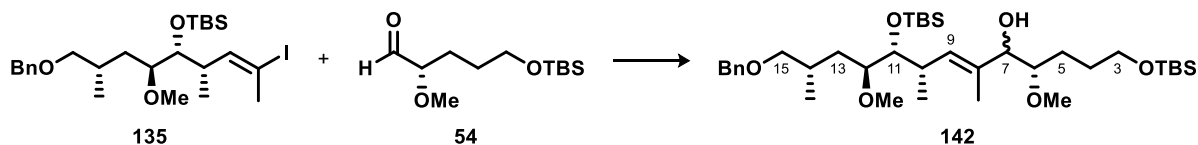

Vinyl iodide **135** (74 mg, 0.135 mmol, 1.0 eq.) as well as aldehyde **54** (50 mg, 0.203 mmol, 1.5 eq.) were dried prior to use by stirring over activated molecular sieves (pellets, 3 Å) in CH<sub>2</sub>Cl<sub>2</sub> (5 mL) overnight in the absence of light in separate flasks. In a glovebox, CrCl<sub>2</sub> (145 mg, 1.18 mmol, 8.7 eq.) was placed in a sealed tube and further dried at 230 °C under high vacuum for 2.5 h. The tube was allowed to reach room temperature and it was transferred to the glovebox where NiCl<sub>2</sub> (4.6 mg, 0.035 mmol, 3%w related to amount of CrCl<sub>2</sub>) was added. The vinyl iodide and the aldehyde were combined into one flask and the solvent was removed under high vacuum without additional heating. After drying for 1.5 h the starting materials were dissolved in DMSO (degassed in ultrasonic bath for 30 min, 1 mL) and transferred to the reaction tube containing CrCl<sub>2</sub> and NiCl<sub>2</sub>. The mixture was stirred for 42 h at room temperature. The reaction was terminated by the addition of a saturated aqueous NH<sub>4</sub>Cl solution (1 mL). The phases were separated and the aqueous phase was extracted with EtOAc (3 x 5 mL). The combined organic phases were washed with saturated aqueous NaHCO<sub>3</sub> solution (5 mL), brine (5 mL), dried over MgSO<sub>4</sub>, filtered and the solvent was removed under reduced pressure. The crude product was purified by flash column chromatography (PE/MTBE = 10:1 → 4:1) to yield racemic alcohol **142** (23 mg, 0.035 mmol, 26%, 7(*S*):7(*R*) *d.r.* = 1:1) as a colorless oil.

**R<sub>f</sub>** = 0.2 (PE/EtOAc = 8:1);

**<sup>1</sup>H-NMR** (400 MHz, CDCl<sub>3</sub>, CHCl<sub>3</sub> = 7.26 ppm): δ 7.33 – 7.26 (m, 10H, Bn), 5.32 – 5.27 (m, 2H, H-9), 4.50 (s, 4H, Bn), 4.13 (d, *J* = 3.5 Hz, 1H, H-7(*S*))<sup>18</sup>, 3.83 (d, *J* = 6.7 Hz, 1H, H-7(*R*)), 3.61 – 3.57 (m, 6H, H-3, H-11), 3.42 (s, 3H, OMe), 3.41 (s, 3H, OMe), 3.38 – 3.32 (m, 2H, H-15), 3.28 (s, 3H, OMe), 3.27 (s, 3H, OMe), 3.26 – 3.22 (m, 4H, H-6, H-15'), 3.14 – 3.11 (m, 1H, H-12), 3.09 – 3.07 (m, 1H, H-12<sub>Dia</sub>)<sup>19</sup>, 2.49 – 2.41 (m, 2H, H-10), 1.98 – 1.92 (m, 2H, H-14), 1.74 – 1.45 (m, 10H, H-4, H-5, H-13), 1.62 (d, *J* = 1.2 Hz, 3H, Me-8), 1.60 (d, *J* = 1.1 Hz, Me-8<sub>Dia</sub>), 1.15 – 1.04 (m, 2H, H-13'), 1.00 (d, *J* = 6.1 Hz, Me-10), 0.98 (d, *J* = 6.3 Hz, Me-10<sub>Dia</sub>), 0.90 – 0.88 (m, 42H, 4xTBS, Me-14), 0.07 (s, 6H, TBS), 0.05 – 0.04 (m, 18H, 3xTBS) ppm;

**<sup>13</sup>C-NMR** (600 MHz, CDCl<sub>3</sub>, CDCl<sub>3</sub> = 77.16 ppm): δ 139.1 (s, Bn), 139.0 (s, Bn<sub>Dia</sub>), 133.7 (s, C-8), 132.9 (s, C-8<sub>Dia</sub>), 132.2 (d, C-9), 130.2 (d, C-9<sub>Dia</sub>), 128.4 (d, 4C, Bn), 127.6 (d, 4C, Bn), 127.4 (d, 2C, Bn), 81.9 (d, 2C, C-6), 81.7 (d, 2C, C-12), 78.8 (d, C-7), 76.5 (d, 2C, C-11), 76.4 (t, 2C, C-15), 75.9 (d, C-7<sub>Dia</sub>), 72.9 (t, 2C, Bn), 63.6 (t, C-3), 63.5 (t, C-3<sub>Dia</sub>), 58.1 (q, OMe), 57.9 (q, OMe), 57.3 (q, OMe<sub>Dia</sub>), 57.3 (q, OMe<sub>Dia</sub>), 36.0 (d, C-10), 35.8 (d, C-10), 33.2

<sup>18</sup> The assignment of the absolute configuration at C-7 was based on a comparison with experimental data of the SNAC ester of 8-des-methyl-*seco*-progeldanamycin and intermediate structures of this synthesis from studies in our group.<sup>[75]</sup>

<sup>19</sup> The index "Dia" is not defined more precisely. No distinction is made between desired and undesired diastereomer.

(t, C-13), 33.1 (t, C-13<sub>Dia</sub>), 30.3 (d 2C, C.14), 28.2 (t, 2C, C-5), 27.1 (t, 2C, C-4), 26.3 (q, 6C, TBS), 26.1 (q, 6C, TBS), 22.9 (s, 4C, TBS), 18.5 (q, Me-10), 17.3 (q, Me-10<sub>Dia</sub>), 17.0 (q, Me-14), 14.3 (q, Me-14<sub>Dia</sub>), 13.7 (q, Me-8), 12.6 (q, Me-8<sub>Dia</sub>), -3.7 (q, TBS), -4.6 (q, TBS<sub>Dia</sub>), -5.14 (q, 2C, TBS) ppm;

**HRMS-ESI**  $m/z$  for C<sub>37</sub>H<sub>70</sub>O<sub>6</sub>SiNa [M+Na]<sup>+</sup> calc. 689.4609, found 689.4607.

**(5*R*,6*S*,10*S*,*E*)-5-((1*S*,3*S*)-4-(Benzyloxy)-1-methoxy-3-methylbutyl)-10-methoxy-2,2,3,3,6,8,15,15,16,16-decamethyl-4,14-dioxa-3,15-disilaheptadec-7-en-9-one (144)**

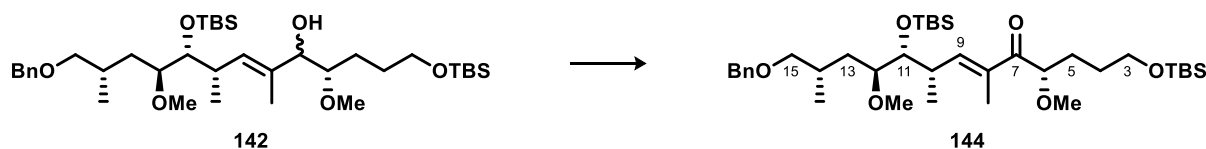

Racemic alcohol **142** (26 mg, 0.039 mmol, 1.0 eq.) was dissolved in CH<sub>2</sub>Cl<sub>2</sub> (0.8 mL) and cooled to 0 °C. NaHCO<sub>3</sub> (16 mg, 0.195 mmol, 5.0 eq.) was added followed by DMP (30 mg, 0.070 mmol, 1.8 eq.) and the mixture was stirred at this temperature for 15 min before the mixture was allowed to reach room temperature and stirring was continued for 2 h. The reaction was diluted with CH<sub>2</sub>Cl<sub>2</sub> (10 mL) and terminated by the addition of Na<sub>2</sub>S<sub>2</sub>O<sub>3</sub> (10 w%) in a saturated aqueous NaHCO<sub>3</sub> solution (10 mL). Stirring was continued until a clear organic phase was obtained. The phases were separated and the aqueous phase was extracted with CH<sub>2</sub>Cl<sub>2</sub> (3 x 10 mL). The combined organic phases were dried over MgSO<sub>4</sub>, filtered and the solvent was removed under reduced pressure. The crude product was purified by flash column chromatography (PE/EtOAc = 10:1) to yield enone **144** (16 mg, 0.23 mmol, 60%) as a colorless oil.

**R<sub>f</sub>** = 0.6 (PE/EtOAc = 4:1);

**<sup>1</sup>H-NMR** (400 MHz, CDCl<sub>3</sub>, CHCl<sub>3</sub> = 7.26 ppm): δ 7.33 – 7.24 (m, 5H, Bn), 6.66 (dq,  $J = 1.4, 10.3$  Hz, 1H, H-9), 4.49 (s, 2H, Bn), 4.29 (dd,  $J = 5.0, 7.9$  Hz, 1H, H-6), 3.67 (dd,  $J = 1.6, 8.0$  Hz, 1H, H-11), 3.65 – 3.55 (m, 2H, H-3), 3.34 – 3.29 (m, 4H, OMe, H-15), 3.28 – 3.21 (m, 4H, OMe, H-15'), 3.07 (dt,  $J = 2.0, 10.5$  Hz, 1H, H-12), 2.71 – 2.62 (m, 1H, H-10), 1.97 – 1.90 (m, 1H, H-14), 1.81 (d,  $J = 1.2$  Hz, 3H, Me-8), 1.78 – 1.63 (m, 3H, H-5, H-13), 1.61 – 1.53 (m, 2H, H-4), 1.09 (d,  $J = 6.7$  Hz, 3H, Me-10), 1.06 – 1.02 (m, 1H, H-13'), 0.92 (s, 9H, TBS), 0.88 (s, 9H, TBS), 0.85 (d,  $J = 6.7$  Hz, 3H, Me-14), 0.09 (s, 3H, TBS), 0.07 (s, 3H, TBS), 0.03 (s, 3H, TBS), 0.03 (s, 3H, TBS) ppm;

**<sup>13</sup>C-NMR** (400 MHz, CDCl<sub>3</sub>, CDCl<sub>3</sub> = 77.16 ppm): δ 201.9 (s, C-7), 145.9 (d, C-9), 139.0 (s, Bn), 134.6 (s, C-8), 128.4 (d, 2C, Bn), 127.6 (d, 2C, Bn), 127.5 (d, Bn), 83.5 (d, C-6), 82.3 (d, C-12), 76.6 (d, C-11), 76.4 (t, C-15), 73.0 (t, Bn), 62.8 (t, C-3), 57.8 (q, OMe), 57.2 (q, OMe), 37.5 (d, C-10), 33.6 (t, C-13), 30.1 (d, C-14), 30.0 (t, C-5), 29.0 (t, C-4), 26.3 (q, 3C, TBS), 26.1 (q, 3C, TBS), 18.6 (s, TBS), 18.5 (s, TBS), 17.0 (q, Me-10), 16.9 (q, Me-14), 12.1 (q, Me-8), -3.6 (q, TBS), -4.6 (q, TBS), -5.2 (q, 2C, TBS) ppm;

**[α]<sub>D</sub><sup>20</sup>** = -23.9 ( $c = 1.0$ , CHCl<sub>3</sub>);

**HRMS-ESI**  $m/z$  for C<sub>37</sub>H<sub>68</sub>O<sub>6</sub>Si<sub>2</sub>Na [M+Na]<sup>+</sup> calc. 687.4452, found 687.4451.

**(5*R*,6*S*,10*S*,*E*)-5-((1*S*,3*S*)-4-(Benzyloxy)-1-methoxy-3-methylbutyl)-10-methoxy-2,2,3,3,6,8,15,15,16,16-decamethyl-4,14-dioxa-3,15-disilaheptadec-7-en-9-ol (142)**

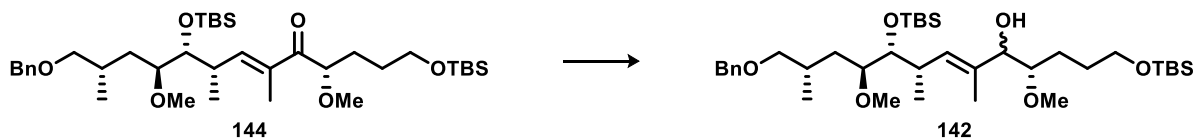

(*S*)-2-Methyl-CBS-oxazaborolidine (1 M in THF, 389  $\mu$ L, 0.389 mmol 14.0 eq.) was dissolved in THF (1.8 mL) and cooled to  $-30$   $^{\circ}$ C. Borane dimethylsulfid complex (8  $\mu$ L, 0.083 mmol, 3.0 eq.) was added followed by dropwise addition of enone **144** (18.5 mg, 0.028 mmol, 1.0 eq.) as a solution in THF (1 mL). The reaction was warmed to  $-10$   $^{\circ}$ C and stirred for 6 h. The reaction was terminated by the addition of MeOH (2 mL). Water (5 mL) was added and the phases were separated and the aqueous phase was extracted with MTBE (3 x 5 mL). The combined organic phases were dried over MgSO<sub>4</sub>, filtered and the solvent was removed under reduced pressure. The crude product was purified by flash column chromatography (PE/EtOAc = 15:1  $\rightarrow$  2:1) to yield racemic alcohol **142** (9.3 mg, 0.014 mmol, 50%, *d.r.* = 1:1) as a colorless oil. The diastereomers could not be separated. The analytical data are consistent with those reported on page 133.

**(2*S*,4*S*,5*R*,6*S*)-5-((*tert*-Butyldimethylsilyl)oxy)-4-methoxy-2,6-dimethylnon-7-yn-1-ol (187)**

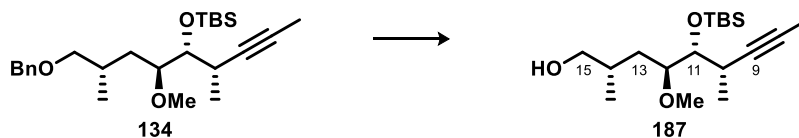

Benzyl ether **134** (278 mg, 0.664 mmol, 1.0 eq.) was dissolved in THF (6 mL) and cooled to  $-78$   $^{\circ}$ C and LiDBB solution ( $\sim$  0.3 M, 4.5 mL, 1.59 mmol, 2.4 eq.) was added slowly. Completion of the reaction could be judged by the persisting blue color of the reaction solution. The reaction was carefully terminated by the addition of a saturated aqueous NH<sub>4</sub>Cl solution (exothermic reaction!). Once the exothermic reaction subsided, the phases were separated and the aqueous phase was extracted with EtOAc (3 x 10 mL). The combined organic phases were dried over MgSO<sub>4</sub>, filtered and the solvent was removed under reduced pressure. The crude product was purified by flash column chromatography (PE/EtOAc = 10:1  $\rightarrow$  5:1) to yield alcohol **187** (182 mg, 0.554 mmol, 83%) as a colorless oil.

$R_f$  = 0.3 (PE/EtOAc = 4:1);

**<sup>1</sup>H-NMR** (400 MHz, CDCl<sub>3</sub>, CHCl<sub>3</sub> = 7.26 ppm):  $\delta$  3.67 (dd,  $J$  = 9.0, 1.4 Hz, 1H, H-11), 3.58 (dt,  $J$  = 10.1, 1.6 Hz, 1H, H-12), 3.53 (dd,  $J$  = 10.8, 5.0 Hz, 1H, H-15), 3.40 (dd,  $J$  = 10.8, 6.0 Hz, 1H, H-15'), 3.37 (s, 3H, OMe), 2.36 – 2.31 (m, 1H, H-10), 2.25 (bs, 1H, OH), 1.80 – 1.72 (m, 1H, H-14), 1.78 (d,  $J$  = 2.4 Hz, 3H, Me-8), 1.57 (ddd,  $J$  = 15.0, 10.1, 6.9 Hz, 1H, H-13), 1.36 – 1.30 (m, 1H, H-13'), 1.19 (d,  $J$  = 6.8 Hz, 3H, Me-10), 0.96 (d,  $J$  = 6.8 Hz, 3H, Me-14), 0.89 (s, 9H, TBS), 0.08 (s, 3H, TBS), 0.06 (s, 3H, TBS) ppm;

**<sup>13</sup>C-NMR** (400 MHz, CDCl<sub>3</sub>, CDCl<sub>3</sub> = 77.16 ppm):  $\delta$  83.3 (d, C-12), 81.3 (s, C-9), 78.1 (s, C-8), 75.7 (d, C-11), 68.7 (t, C-15), 56.9 (q, OMe), 34.2 (d, C-14), 33.5 (t, C-13), 30.2 (d, C-10),

26.2 (q, 3C, TBS), 18.9 (q, Me-10), 18.6 (s, TBS), 18.2 (q, Me-14), 3.6 (q, Me-8), -3.7 (q, TBS), -4.6 (q, TBS) ppm;

$[\alpha]_D^{20} = -23.0$  ( $c = 0.9$ ,  $\text{CH}_2\text{Cl}_2$ );

**HRMS-ESI**  $m/z$  for  $\text{C}_{18}\text{H}_{36}\text{O}_3\text{SiNa}$   $[\text{M}+\text{Na}]^+$  calc. 351.2332, found 351.2331.

**(2*S*,4*S*,5*R*,6*S*)-5-((*tert*-Butyldimethylsilyl)oxy)-4-methoxy-2,6-dimethylnon-7-ynal (**197**)**

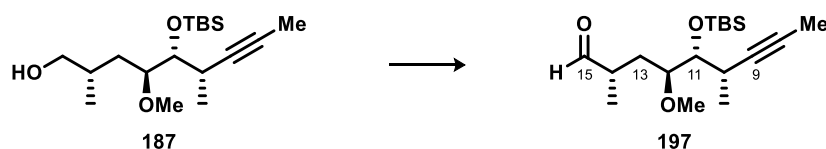

Alcohol **187** (50 mg, 0.152 mmol, 1.0 eq.) was dissolved in  $\text{CH}_2\text{Cl}_2$  (1 mL) and cooled to 0 °C.  $\text{NaHCO}_3$  (94 mg, 0.761 mmol, 5.0 eq.) was added followed by DMP (116 mg, 0.274 mmol, 1.8 eq.). Stirring was continued at this temperature for 15 min before the mixture was allowed to reach room temperature and stirring was continued for 2 h. The reaction was diluted with  $\text{CH}_2\text{Cl}_2$  (10 mL) and terminated by the addition of  $\text{Na}_2\text{S}_2\text{O}_3$  (10 w%) in a saturated aqueous  $\text{NaHCO}_3$  solution. Stirring was continued until a clear organic phase was obtained. The phases were separated and the aqueous phase was extracted with  $\text{CH}_2\text{Cl}_2$  (3 x 5 mL). The combined organic phases were dried over  $\text{MgSO}_4$ , filtered and the solvent was removed under reduced pressure. The crude product was purified by flash column chromatography (PE/EtOAc = 10:1) to yield aldehyde **197** (32 mg, 0.136 mmol, 90%) as a colorless oil which was used in the next step without further analysis.

$R_f = 0.6$  (PE/EtOAc = 4:1).

**(2*S*,4*S*,5*R*,6*S*)-1-(3-(Allyloxy)-5-(diallylamino)phenyl)-5-((*tert*-butyldimethylsilyl)oxy)-4-methoxy-2,6-dimethylnon-7-yn-1-ol (**219**)**

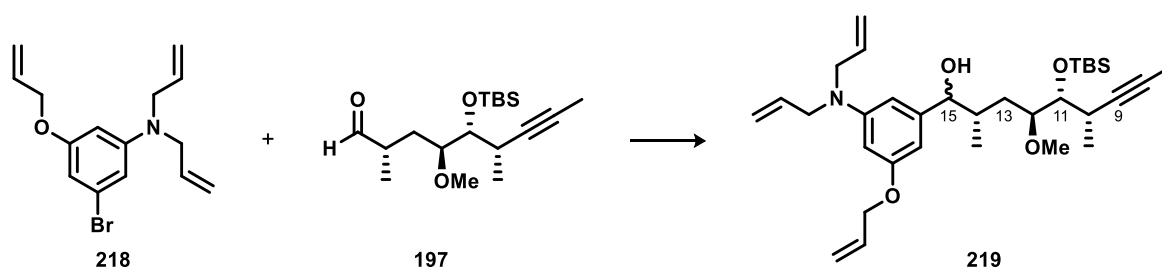

Aryl bromide **218** (30 mg, 0.097 mmol, 2.0 eq.) was dissolved in  $\text{Et}_2\text{O}$  (1 mL) and cooled to -78 °C.  $t\text{-BuLi}$  (1.69 M in pentane, 115  $\mu\text{L}$ , 0.195 mmol, 4.0 eq.) was added and stirring was continued for 15 min. Aldehyde **197** (16 mg, 0.049 mmol, 1.0 eq.) dissolved in  $\text{Et}_2\text{O}$  (1 mL) was added to the reaction and stirring was continued for 30 min at -78 °C. The reaction was terminated by the addition of a saturated aqueous  $\text{NH}_4\text{Cl}$  solution. The phases were separated and the aqueous phase was extracted with MTBE (3 x 5 mL). The combined organic phases were dried over  $\text{MgSO}_4$ , filtered and the solvent was removed under reduced pressure. The crude product was purified by flash column chromatography (100% PE  $\rightarrow$  PE/EtOAc = 20:1) to yield racemic alcohol **219** (9.3 mg, 0.017 mmol, 35%) as a colorless oil.

$R_f = 0.4$  (PE/EtOAc = 4:1);

**<sup>1</sup>H-NMR** (600 MHz, CDCl<sub>3</sub>, CHCl<sub>3</sub> = 7.26 ppm): δ 6.29 – 6.18 (m, 6H, H<sub>Ar</sub>), 6.08 – 6.01 (m, 2H, O-allyl), 5.86 – 5.82 (m, 4H, N(allyl)<sub>2</sub>), 5.40 (d, *J* = 17.2 Hz, 2H, O-allyl), 5.26 (d, *J* = 9.9 Hz, 2H, O-allyl), 5.18 – 5.16 (m, 8H, N(allyl)<sub>2</sub>), 4.51 – 4.50 (m, 4H, O-allyl), 3.89 (bs, 8H, N(allyl)<sub>2</sub>), 3.68 – 3.57 (m, 5H, H-11, H-12, H-15), 3.40 – 3.36 (m, 4H, OMe, H-15<sub>Dia</sub>), 3.35 (s, 3H, OMe<sub>Dia</sub>), 2.33 – 2.30 (m, 2H, H-10), 2.01 – 1.92 (m, 2H, H-14), 1.78 (d, *J* = 2.3 Hz, 3H, Me-8), 1.77 (d, *J* = 2.4 Hz, 3H, Me-8<sub>Dia</sub>), 1.58 (m, 2H, H-13, H-13<sub>Dia</sub>), 1.36 – 1.29 (m, 2H, H-13, H-13'<sub>Dia</sub>), 1.19 (d, *J* = 3.7 Hz, Me-10), 1.18 (d, *J* = 3.7 Hz, 3H, Me-10<sub>Dia</sub>), 0.88 – 0.84 (m, 21H, TBS, TBS<sub>Dia</sub>, Me-14), 0.80 (d, *J* = 6.8 Hz, 3H, Me-14<sub>Dia</sub>), 0.06 (s, 3H, TBS), 0.05 (s, 3H, TBS), 0.03 (s, 3H, TBS), 0.01 (s, 3H, TBS) ppm;

**<sup>13</sup>C-NMR** (600 MHz, CDCl<sub>3</sub>, CDCl<sub>3</sub> = 77.16 ppm): δ 159.7 (s, C<sub>Ar</sub>), 134.2 (d, 2C, N(allyl)<sub>2</sub>), 133.8 (d, O-allyl), 133.0 (s, C<sub>Ar</sub>), 132.7 (s, C<sub>Ar</sub>), 118.2 (d, C<sub>Ar</sub>), 117.7 (t, 2C, N(allyl)<sub>2</sub>), 116.2 (t, O-allyl), 100.8 (d, C<sub>Ar</sub>), 98.8 (d, C<sub>Ar</sub>), 82.8 (d, C-12), 81.6 (s, C-9), 77.8 (s, C-8), 76.0 (d, C-11), 69.0 (d, C-15), 57.4 (q, OMe), 57.1 (t, O-allyl), 53.0 (t, 2C, N(allyl)<sub>2</sub>), 33.0 (t, C-13), 32.7 (d, C-14), 30.1 (d, C-10), 26.2 (q, 3C, TBS), 18.9 (q, Me-10), 18.5 (s, TBS), 14.9 (q, Me-14), 3.6 (q, Me-8), -3.7 (q, TBS), -4.6 (q, TBS) ppm;

**HRMS-ESI** *m/z* for C<sub>33</sub>H<sub>53</sub>NO<sub>4</sub>SiNa [M+Na]<sup>+</sup> calc. 578.3642, found 578.3639.

**O-((2*S*,4*S*,6*S*)-1-(3-(Allyloxy)-5-(diallylamino)phenyl)-5-((*tert*-butyldimethylsilyl)oxy)-4-methoxy-2,6-dimethylnon-7-yn-1-yl) S-methyl carbonodithioate (**353**)**

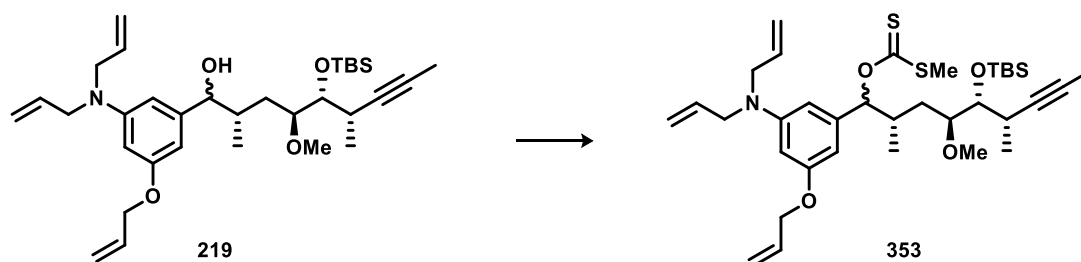

Alcohol **219** (8 mg, 0.014 mmol, 1.0 eq.) was dissolved in THF (2 mL) and NaHMDS (1 M in THF, 43 μL, 0.043 mmol, 3.0 eq.) was added and stirred for 30 min at room temperature. The mixture was cooled to 0 °C and CS<sub>2</sub> (26 μL, 0.432 mmol, 30.0 eq.) was added. Stirring was continued for 15 min before MeI (27 mL, 0.432 mmol, 30.0 eq.) was added. After 1 h the reaction was terminated by the addition of water. The phases were separated and the aqueous phase was extracted with EtOAc (3 x 10 mL). The combined organic phases were dried over MgSO<sub>4</sub>, filtered and the solvent was removed under reduced pressure. The crude product was purified by flash column chromatography (PE/EtOAc = 10:1) to yield methylxanthate **353** (3 mg, 5.0 μmol, 32%, 40% brsm) as a yellow oil which was used in the next step without further analysis.

**R<sub>f</sub>** = 0.6 (PE/EtOAc = 4:1);

**LRMS-ESI** *m/z* for C<sub>35</sub>H<sub>55</sub>NO<sub>4</sub>S<sub>2</sub>SiNa [M+Na]<sup>+</sup> calc. 668.32, found 668.30.

***N,N*-Diallyl-3-(allyloxy)-5-((2*R*,4*S*,6*S*)-5-((*tert*-butyldimethylsilyl)oxy)-4-methoxy-2,6-dimethylnon-7-yn-1-yl)aniline (**229**)**

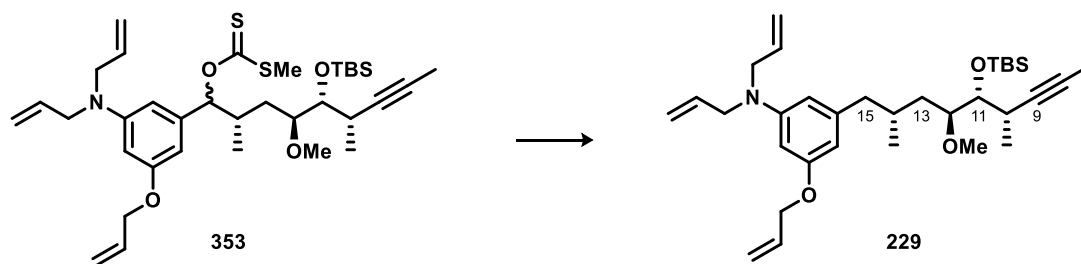

To a solution of methylxanthate **353** (8 mg, 12.4  $\mu\text{mol}$ , 1.0 eq.) in PhMe (degassed in ultrasonic bath for 20 min, 1 mL)  $\text{Bu}_3\text{SnH}$  (8  $\mu\text{L}$ , 31.0  $\mu\text{mol}$ , 2.5 eq.) and  $\text{Et}_3\text{B}$  (1 M in hexane, 3  $\mu\text{L}$ , 2.5  $\mu\text{mol}$ , 0.2 eq.) was added. A needle was applied to the septum allowing air to enter the system slowly and the mixture was stirred for 1 h at room temperature. The solvent was removed under reduced pressure and the crude product was purified by flash column chromatography (PE/EtOAc = 30:1  $\rightarrow$  20:1) to yield 1.5 mg of a colorless oil containing the desired product **229** along with alkylstannane impurities, that could not be removed entirely.

$R_f$  = 0.5 (PE/EtOAc = 10:1);

$^1\text{H-NMR}$  (600 MHz,  $\text{CDCl}_3$ ,  $\text{CHCl}_3$  = 7.26 ppm):  $\delta$  6.11 – 5.99 (m, 3H,  $\text{H}_{\text{Ar}}$ ), 5.90 – 5.78 (m, 3H, allyl), 5.42 – 5.14 (m, 6H, allyl), 4.49 – 4.45 (m, 2H, O-allyl), 3.90 – 3.85 (m, 4H,  $\text{N}(\text{allyl})_2$ ), 3.63 (dd,  $J$  = 8.7, 1.7 Hz, 2H, H-11), 3.57 (dt,  $J$  = 10.1, 2.0 Hz, 1H, H-12), 3.33 (s, 3H, OMe), 2.55 (dd,  $J$  = 13.4, 6.7 Hz, 1H, H-15), 2.34 – 2.29 (m, 2H, H-10, H-15'), 1.99 – 1.90 (m, 1H, H-14), 1.77 (d,  $J$  = 2.4 Hz, 3H, Me-8), 1.68 – 1.61 (m, 1H, H-13), 1.19 (d,  $J$  = 2.1 Hz, 3H, Me-10), 1.12 – 1.09 (m, 1H, H-13'), 0.85 (bs, 12H, Me-14, TBS), 0.04 (s, 3H, TBS), 0.02 (s, 3H, TBS) ppm;

**HRMS-ESI**  $m/z$  for  $\text{C}_{33}\text{H}_{53}\text{NO}_3\text{SiNa}$   $[\text{M}+\text{Na}]^+$  calc. 562.3693, found 562.3690.

**(2*S*,4*S*,5*R*,6*S*)-5-((*tert*-Butyldimethylsilyl)oxy)-1-(3-(diallylamino)-5-(methoxymethoxy)phenyl)-4-methoxy-2,6-dimethylnon-7-yn-1-ol (**234**)**

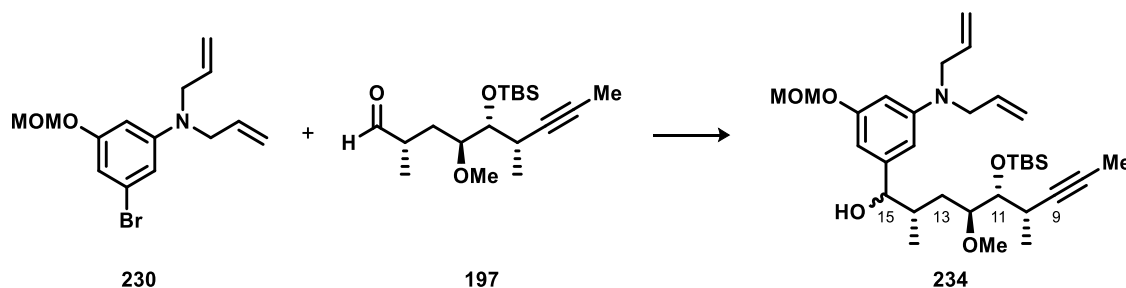

Aryl bromide **230** (221 mg, 0.707 mmol, 3.0 eq.) was dissolved in  $\text{Et}_2\text{O}$  (7 mL) and cooled to  $-78^\circ\text{C}$ .  $t\text{-BuLi}$  (1.69 M in pentane, 880  $\mu\text{L}$ , 1.49 mmol, 6.3 eq.) was added and stirring was continued for 1 h. Aldehyde **197** (77 mg, 0.236 mmol, 1.0 eq.) dissolved in  $\text{Et}_2\text{O}$  (2.4 mL) was added dropwise via a syringe pump. Stirring was continued for 4 h at  $-78^\circ\text{C}$ . The reaction was terminated by the addition of a saturated aqueous  $\text{NH}_4\text{Cl}$  solution. The phases



were separated and the aqueous phase was extracted with MTBE (3 x 10 mL). The combined organic phases were dried over MgSO<sub>4</sub>, filtered and the solvent was removed under reduced pressure. The crude product was purified by flash column chromatography (100% PE → PE/EtOAc = 20:1) to yield a diastereomeric mixture of alcohol **234** (77 mg, 0.138 mmol, 58%, *d.r.* = 1:1.4) as a pale yellow oil.

**R<sub>f</sub>** = 0.2 (PE/EtOAc = 4:1);

**<sup>1</sup>H-NMR** (400 MHz, CDCl<sub>3</sub>, CHCl<sub>3</sub> = 7.26 ppm): δ 6.38 – 6.35 (m, 2H, H<sub>Ar</sub>), 6.29 (s, 1H, H<sub>Ar</sub>), 5.88 – 5.81 (m, 2H, allyl), 5.19 – 5.11 (m, 6H, MOM, allyl), 4.46 (d, *J* = 4.7 Hz, 1H, H-15<sub>minor</sub>), 4.25 (d, *J* = 7.3 Hz, 1H, H-15<sub>major</sub>), 3.89 (d, *J* = 4.8 Hz, 4H, allyl), 3.68 – 3.63 (m, 1H, H-11), 3.61 – 3.56 (m, 1H, H-12), 3.47 (s, 3H, MOM), 3.38 (s, 3H, OMe<sub>major</sub>), 3.34 (s, 3H, OMe<sub>minor</sub>), 2.36 – 2.30 (m, 1H, H-10), 2.01 – 1.89 (m, 1H, H-14), 1.88 – 1.82 (m, 1H, H-13<sub>minor</sub>), 1.78 (d, *J* = 2.4 Hz, 3H, Me-8<sub>minor</sub>), 1.77 (d, *J* = 2.4 Hz, 3H, Me-8<sub>major</sub>), 1.62 (bs, 1H, OH), 1.59 – 1.49 (1H, m, H-13<sub>major</sub>), 1.32 – 1.21 (m, 1H, H-13'), 1.18 (d, *J* = 6.8 Hz, 3H, Me-10<sub>major</sub>), 1.17 (d, *J* = 6.8 Hz, 3H, Me-10<sub>minor</sub>), 0.91 – 0.87 (m, 11H, TBS<sub>major</sub>, Me-14<sub>minor</sub>), 0.83 (s, 9H, TBS<sub>minor</sub>), 0.81 (d, *J* = 6.8 Hz, 3H, Me-14<sub>major</sub>), 0.05 (s, 3H, TBS<sub>major</sub>), 0.05 (s, 3H, TBS<sub>major</sub>), 0.02 (s, 3H, TBS<sub>minor</sub>), -0.01 (s, 3H, TBS<sub>minor</sub>) ppm;

**<sup>13</sup>C-NMR** (400 MHz, CDCl<sub>3</sub>, CDCl<sub>3</sub> = 77.16 ppm): δ 158.3 (s, C<sub>Ar</sub>), 151.1 (s, C<sub>Ar</sub>), 145.6 (s, C<sub>Ar</sub>), 134.0 (d, 2C, allyl), 116.1 (t, 2C, allyl), 105.9 (d, C<sub>Ar</sub>), 102.6 (d, C<sub>Ar</sub>), 99.7 (d, C<sub>Ar</sub>), 94.7 (t, MOM), 82.5 (d, C-12), 82.1 (d, C-15<sub>major</sub>), 81.3 (s, C-9), 80.2 (d, C-15<sub>minor</sub>), 77.8 (s, C-8), 75.9 (d, C-11<sub>minor</sub>), 75.8 (d, C-11<sub>major</sub>), 57.2 (q, OMe<sub>major</sub>), 57.0 (q, OMe<sub>minor</sub>), 56.0 (q, MOM), 52.8 (t, 2C, allyl), 37.8 (d, C-14<sub>major</sub>), 37.2 (d, C-14<sub>minor</sub>), 32.8 (t, C-13<sub>major</sub>), 32.6 (t, C-13<sub>minor</sub>), 29.9 (d, C-10), 26.1 (q, 3C, TBS), 18.7 (s, TBS), 18.4 (q, Me-10<sub>major</sub>), 18.4 (q, Me-10<sub>minor</sub>), 17.4 (q, Me-14<sub>minor</sub>), 14.8 (q, Me-14<sub>major</sub>), 3.5 (q, Me-8), -3.9 (q, TBS<sub>major</sub>), -3.9 (q, TBS<sub>minor</sub>), -4.8 (q, TBS<sub>major</sub>), -4.9 (q, TBS<sub>minor</sub>) ppm;

**HRMS-ESI** *m/z* for C<sub>32</sub>H<sub>53</sub>NO<sub>5</sub>SiNa [M+Na]<sup>+</sup> calc. 582.3591, found 582.3591.

***O*-((2*S*,4*S*,5*R*,6*S*)-5-((*tert*-Butyldimethylsilyl)oxy)-1-(3-(diallylamino)-5-(methoxymethoxy)phenyl)-4-methoxy-2,6-dimethylnon-7-yn-1-yl) *S*-methyl carbonodithioate (**354**)**

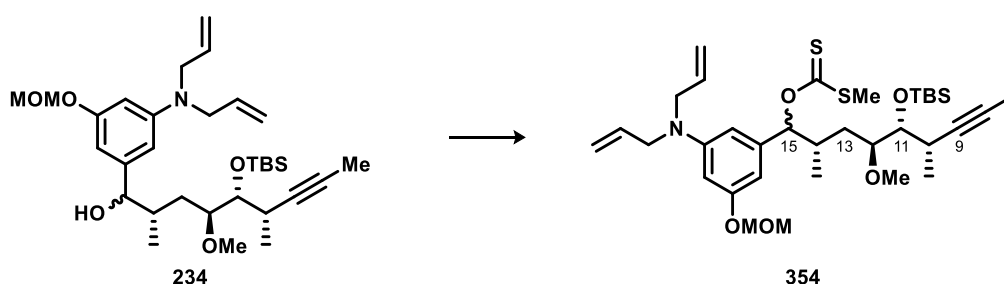

Benzylic alcohol **234** (77 mg, 0.138 mmol, 1.0 eq.) was dissolved in THF (1.4 mL) and NaHMDS (1 M in THF, 413 μL, 0.413 mmol, 3.0 eq.) was added at room temperature. After stirring for 15 min CS<sub>2</sub> (42 μL, 0.688 mmol, 5.0 eq.) was added and the resulting deep-orange turbid solution was stirred for 20 min. MeI (60 μL, 0.963 mmol, 7.0 eq.) was added and the solution cleared up immediately. After 20 min stirring at room temperature the mixture was diluted with MTBE (10 mL) and washed with a saturated aqueous NaH<sub>2</sub>PO<sub>4</sub> solution. The

organic phase was dried over  $\text{MgSO}_4$ , filtered and the solvent was removed under reduced pressure. The crude product was purified by flash column chromatography (PE/EtOAc = 10:1  $\rightarrow$  5:1) to yield a diastereomeric mixture of methylxanthate **354** (67 mg, 0.102 mmol, 74%, *d.r.* = 1:1.4) as a yellow oil which was of sufficient purity to be used in the next step.

$R_f$  = 0.6 (PE/EtOAc = 4:1);

$^1\text{H-NMR}$  (400 MHz,  $\text{CDCl}_3$ ,  $\text{CHCl}_3$  = 7.26 ppm):  $\delta$  6.34 – 6.29 (m, 4H,  $\text{H}_{\text{Ar}}$ , H-15), 5.88 – 5.79 (m, 2H, allyl), 5.20 – 5.09 (m, 6H, MOM, allyl), 3.87 – 3.86 (m, 4H, allyl), 3.66 – 3.56 (m, 2H, H-11, H-12), 3.46 (s, 3H, MOM), 3.34 (s, 3H,  $\text{OMe}_{\text{minor}}$ ), 3.31 (s, 3H,  $\text{OMe}_{\text{major}}$ ), 2.54 (s, 3H,  $\text{SMe}_{\text{major}}$ ), 2.53 (s, 3H,  $\text{SMe}_{\text{minor}}$ ), 2.45 – 2.23 (m, 2H, H-10, H-14), 1.86 – 1.77 (m, 1H, H-13<sub>minor</sub>), 1.77 (d,  $J$  = 2.4 Hz, 3H, Me-8<sub>major</sub>), 1.76 (d,  $J$  = 2.5 Hz, 3H, Me-8<sub>minor</sub>), 1.69 – 1.57 (m, 1H, H-13<sub>major</sub>), 1.16 (d,  $J$  = 6.7 Hz, 3H, Me-10), 1.12 – 1.05 (m, 1H, H-13'), 1.01 (d,  $J$  = 6.6 Hz, 3H, Me-14<sub>major</sub>), 0.88 (d,  $J$  = 6.9 Hz, Me-14<sub>minor</sub>), 0.85 (s, 9H, TBS<sub>minor</sub>), 0.79 (s, 9H, TBS<sub>major</sub>), 0.03 (s, 6H, TBS<sub>major</sub>), 0.00 (s, 3H, TBS<sub>minor</sub>), -0.07 (s, 3H, TBS<sub>minor</sub>) ppm;

**HRMS-ESI**  $m/z$  for  $\text{C}_{34}\text{H}_{55}\text{NO}_5\text{S}_2\text{SiNa}$  [ $\text{M}+\text{Na}$ ] $^+$  calc. 672.3189, found 672.3189.

***N,N*-Diallyl-3-((2*R*,4*S*,5*R*,6*S*)-5-((*tert*-butyldimethylsilyl)oxy)-4-methoxy-2,6-dimethylnon-7-yn-1-yl)-5-(methoxymethoxy)aniline**

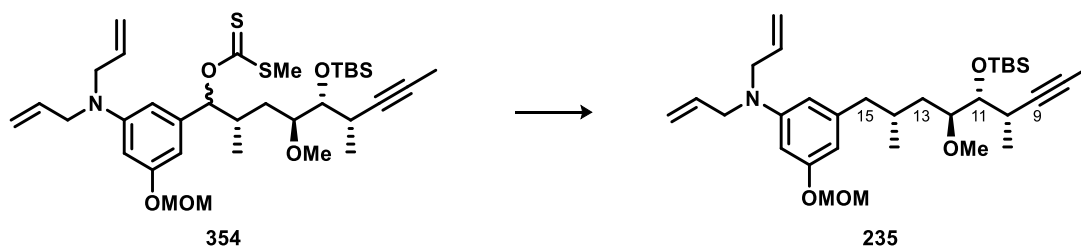

To a solution of methylxanthate **354** (60 mg, 0.092 mmol, 1.0 eq.) in PhMe (degassed in ultrasonic bath for 20 min, 1.8 mL)  $\text{Bu}_3\text{SnH}$  (62  $\mu\text{L}$ , 0.231 mmol, 2.5 eq.) and  $\text{Et}_3\text{B}$  (1 M in hexane, 19  $\mu\text{L}$ , 0.019 mmol, 0.2 eq.) was added. A needle was applied to the septum allowing air to enter the system slowly and the mixture was stirred for 3 h at room temperature. The solvent was removed under reduced pressure and the crude product was purified by flash column chromatography (100% PE  $\rightarrow$  PE/EtOAc = 20:1) to yield compound **235** (26 mg, 0.048 mmol, 52%) as colorless oil along with minor alkylstannane impurities, that could not be removed entirely.

$R_f$  = 0.6 (PE/EtOAc = 10:1);

$^1\text{H-NMR}$  (400 MHz,  $\text{CDCl}_3$ ,  $\text{CHCl}_3$  = 7.26 ppm):  $\delta$  6.22 (s, 2H,  $\text{H}_{\text{Ar}}$ ), 6.19 (s, 1H,  $\text{H}_{\text{Ar}}$ ), 5.89 – 5.80 (m, 2H, allyl), 5.20 – 5.19 (m, 1H, allyl), 5.15 – 5.14 (m, 2H, allyl), 5.13 – 5.12 (m, 3H, allyl, MOM), 3.88 (d,  $J$  = 4.9 Hz, 4H, allyl), 3.63 (dd,  $J$  = 8.6, 1.8 Hz, 1H, H-11), 3.57 (dt,  $J$  = 10.2, 2.0 Hz, 1H, H-12), 3.47 (s, 3H, MOM), 3.33 (s, 3H, OMe), 2.53 (dd,  $J$  = 13.3, 6.3 Hz, 1H, H-15), 2.42 – 2.30 (m, 1H, H-10), 2.33 (dd,  $J$  = 13.2, 8.2 Hz, 1H, H-15'), 1.95 – 1.93 (m, 1H, H-14), 1.77 (d,  $J$  = 2.4 Hz, 3H, Me-8), 1.69 – 1.59 (m, 1H, H-13), 1.18 (d,  $J$  = 6.9 Hz, 3H, Me-10), 1.16 – 1.12 (m, 1H, H-13'), 0.88 (d,  $J$  = 6.5 Hz, 3H, Me-14), 0.85 (s, 9H, TBS), 0.04 (s, 3H, TBS), 0.02 (s, 3H, TBS) ppm;

$^{13}\text{C-NMR}$  (400 MHz,  $\text{CDCl}_3$ ,  $\text{CDCl}_3$  = 77.16 ppm):  $\delta$  158.4 (s,  $\text{C}_{\text{Ar}}$ ), 149.9 (s,  $\text{C}_{\text{Ar}}$ ), 143.5 (s,  $\text{C}_{\text{Ar}}$ ), 134.3 (d, 2C, allyl), 116.1 (t, 2C, allyl), 107.9 (d,  $\text{C}_{\text{Ar}}$ ), 105.2 (d,  $\text{C}_{\text{Ar}}$ ), 98.7 (d,  $\text{C}_{\text{Ar}}$ ), 94.7

(t, MOM), 81.7 (d, C-12), 81.6 (s, C-9), 77.7 (s, C-8), 76.4 (d, C-11), 57.4 (q, OMe), 56.1 (q, MOM), 52.9 (t, 2C, allyl), 45.4 (t, C-15), 36.4 (t, C-13), 31.2 (d, C-14), 29.9 (d, C-10), 26.2 (q, 3C, TBS), 19.3 (q, Me-10), 18.7 (s, TBS), 18.5 (q, Me-14), 3.6 (q, Me-8), -3.8 (q, TBS), -4.6 (q, TBS) ppm;

$[\alpha]_{\text{D}}^{26} = -10.8$  ( $c = 1.0$ ,  $\text{CHCl}_3$ );

HRMS-ESI  $m/z$  for  $\text{C}_{32}\text{H}_{53}\text{NO}_4\text{SiNa}$   $[\text{M}+\text{Na}]^+$  calc. 566.3642, found 566.3641.

**(((2*S*,4*S*,5*R*,6*S*)-4-Methoxy-5-(methoxymethoxy)-2,6-dimethylnon-7-yn-1-yl)oxy)methyl)benzene (**245**)**

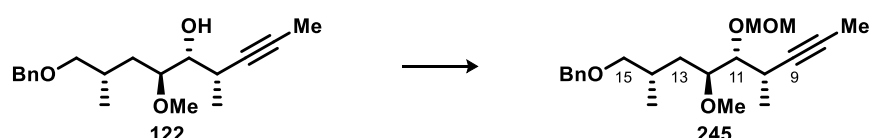

Propargylic alcohol **122** (97 mg, 0.319 mmol, 1.0 eq.) was dissolved in  $\text{CH}_2\text{Cl}_2$  (3 mL) and cooled to 0 °C. MOMCl (73  $\mu\text{L}$ , 0.956 mmol, 3.0 eq.), DIPEA (277  $\mu\text{L}$ , 1.59 mmol, 5.0 eq.), TBAI (24 mg, 0.064 mmol, 0.2 eq.) and DMAP (12 mg, 0.96 mmol, 0.3 eq.) were added subsequently. The reaction mixture was warmed to room temperature and stirred for 30 min before it was stirred for 6 h under refluxing conditions. After cooling to room temperature the reaction was terminated by the addition of a saturated aqueous  $\text{NH}_4\text{Cl}$  solution. The phases were separated and the aqueous phase was extracted with  $\text{CH}_2\text{Cl}_2$  (3 x 10 mL). The combined organic phases were dried over  $\text{MgSO}_4$ , filtered and the solvent was removed under reduced pressure. The crude product was purified by flash column chromatography (PE/EtOAc = 8:1  $\rightarrow$  2:1) to yield MOM ether **245** (89 mg, 0.255 mmol, 80%) as a colorless oil.

$R_f = 0.4$  (PE/EtOAc = 4:1);

$^1\text{H-NMR}$  (400 MHz,  $\text{CDCl}_3$ ,  $\text{CHCl}_3 = 7.26$  ppm):  $\delta$  7.33 – 7.25 (m, 5H, Bn), 4.83 (d,  $J = 6.6$  Hz, 1H, MOM), 4.66 (d,  $J = 6.6$  Hz, 1H, MOM), 4.51 (s, 2H, Bn), 3.69 – 3.65 (m, 2H, H-11, H-12), 3.40 (s, 3H, MOM), 3.39 – 3.36 (m, 4H, OMe, H-15), 3.28 – 3.24 (m, 1H, H-15'), 2.46 – 2.42 (m, 1H, H-10), 2.08 – 1.99 (m, 1H, H-14), 1.78 (d,  $J = 2.4$  Hz, 3H, Me-8), 1.70 – 1.64 (m, 1H, H-13), 1.25 (d,  $J = 6.9$  Hz, 3H, Me-10), 1.27 – 1.23 (m, 1H, H-13'), 0.99 (d,  $J = 6.6$  Hz, 3H, Me-14) ppm;

$^{13}\text{C-NMR}$  (400 MHz,  $\text{CDCl}_3$ ,  $\text{CDCl}_3 = 77.16$  ppm):  $\delta$  139.0 (s, Bn), 128.4 (d, 2C, Bn), 127.7 (d, 2C, Bn), 127.5 (d, Bn), 97.5 (t, MOM), 81.0 (d, C-12), 80.7 (s, C-9), 79.4 (d, C-11), 78.1 (s, C-8), 76.6 (t, C-15), 73.0 (t, Bn), 57.2 (q, OMe), 56.2 (q, MOM), 33.4 (t, C-13), 30.3 (d, C-14), 28.7 (d, C-10), 18.7 (q, Me-10), 16.9 (q, Me-14), 3.6 (q, Me-8) ppm;

$[\alpha]_{\text{D}}^{26} = +9.5$  ( $c = 1.0$ ,  $\text{CHCl}_3$ );

HRMS-ESI  $m/z$  for  $\text{C}_{21}\text{H}_{32}\text{O}_4\text{Na}$   $[\text{M}+\text{Na}]^+$  calc. 371.2199, found 371.2198.

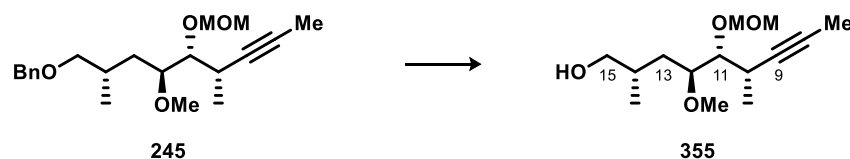
**(2S,4S,5R,6S)-4-Methoxy-5-(methoxymethoxy)-2,6-dimethylnon-7-yn-1-ol (355)**

Benzyl ether **245** (87 mg, 0.248 mmol, 1.0 eq.) was dissolved in THF (1.2 mL) and cooled to  $-78^{\circ}\text{C}$  and LiDBB solution ( $\sim 0.3\text{ M}$ , 2.0 mL, 0.620 mmol, 2.5 eq.) was added slowly. Completion of the reaction could be judged by the persisting blue color of the reaction solution. The reaction was carefully terminated by the addition of a saturated aqueous  $\text{NH}_4\text{Cl}$  solution (exothermic reaction!). Once the exothermic reaction subsided, the phases were separated and the aqueous phase was extracted with EtOAc (3 x 10 mL). The combined organic phases were dried over  $\text{MgSO}_4$ , filtered and the solvent was removed under reduced pressure. The crude product was purified by flash column chromatography (PE/EtOAc = 7:1  $\rightarrow$  100% EtOAc) to yield alcohol **355** (52 mg, 0.202 mmol, 81%) as a colorless oil.

$R_f = 0.1$  (PE/EtOAc = 2:1);

$^1\text{H-NMR}$  (500 MHz,  $\text{CDCl}_3$ ,  $\text{CHCl}_3 = 7.26$  ppm):  $\delta$  4.81 (d,  $J = 6.7$  Hz, 1H, MOM), 4.64 (d,  $J = 6.7$  Hz, 1H, MOM), 3.70 (dd,  $J = 8.9, 1.7$  Hz, 1H, H-11), 3.67 (dt,  $J = 10.0, 1.7$  Hz, 1H, H-12), 3.52 (dd,  $J = 10.8, 5.2$  Hz, 1H, H-15), 3.42 (dd,  $J = 10.9, 6.2$  Hz, 1H, H-15'), 3.40 (s, 3H, MOM), 3.39 (s, 3H, OMe), 2.46 – 2.42 (m, 1H, H-10), 2.24 (bs, 1H, OH), 1.84 – 1.79 (m, 1H, H-14), 1.78 (d,  $J = 2.4$  Hz, 3H, Me-8), 1.61 (ddd,  $J = 14.8, 10.0, 6.4$  Hz, 1H, H-13), 1.42 (ddd,  $J = 14.8, 6.9, 1.8$  Hz, 1H, H-13'), 1.25 (d,  $J = 6.8$  Hz, 3H, Me-10), 0.96 (d,  $J = 6.8$  Hz, 3H, Me-14) ppm;

$^{13}\text{C-NMR}$  (500 MHz,  $\text{CDCl}_3$ ,  $\text{CDCl}_3 = 77.16$  ppm):  $\delta$  97.4 (t, MOM), 82.5 (d, C-12), 80.5 (s, C-9), 78.8 (d, C-11), 78.3 (s, C-8), 68.6 (t, C-15), 56.8 (q, OMe), 56.2 (q, MOM), 34.0 (d, C-14), 33.7 (t, C-13), 28.9 (d, C-10), 18.7 (q, Me-10), 17.9 (q, Me-14), 3.6 (q, Me-8) ppm;

$[\alpha]_D^{25} = +2.6$  ( $c = 1.0$ ,  $\text{CHCl}_3$ );

**HRMS-ESI**  $m/z$  for  $\text{C}_{14}\text{H}_{26}\text{O}_4\text{Na}$   $[\text{M}+\text{Na}]^+$  calc. 281.1729, found 281.1729.

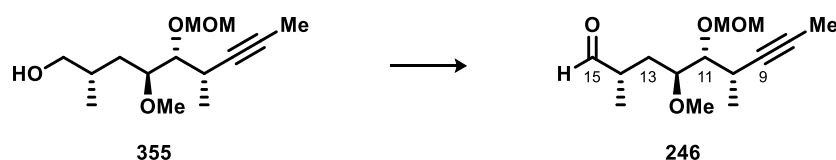
**(2S,4S,5R,6S)-4-Methoxy-5-(methoxymethoxy)-2,6-dimethylnon-7-ynal (246)**

Alcohol **355** (50 mg, 0.194 mmol, 1.0 eq.) was dissolved in  $\text{CH}_2\text{Cl}_2$  (1 mL) and cooled to  $0^{\circ}\text{C}$ .  $\text{NaHCO}_3$  (82 mg, 0.970 mmol, 5.0 eq.) was added followed by DMP (148 mg, 0.349 mmol, 1.8 eq.). Stirring was continued at this temperature for 15 min before the mixture was allowed to reach room temperature and stirring was continued for 1.5 h. The reaction was diluted with  $\text{CH}_2\text{Cl}_2$  and terminated by the addition of  $\text{Na}_2\text{S}_2\text{O}_3$  (10 w%) in a saturated aqueous  $\text{NaHCO}_3$  solution. Stirring was continued until a clear organic phase was obtained. The phases were separated and the aqueous phase was extracted with  $\text{CH}_2\text{Cl}_2$  (3 x 5 mL). The

combined organic phases were dried over  $\text{MgSO}_4$ , filtered and the solvent was removed under reduced pressure. The crude product was purified by flash column chromatography (PE/EtOAc = 10:1) to yield aldehyde **246** (49 mg, 0.190 mmol, 98%) as a colorless oil.

$R_f$  = 0.6 (PE/EtOAc = 2:1);

$^1\text{H-NMR}$  (600 MHz,  $\text{CDCl}_3$ ,  $\text{CHCl}_3$  = 7.26 ppm):  $\delta$  9.50 (d,  $J$  = 3.2 Hz, 1H, H-15), 4.80 (d,  $J$  = 6.6 Hz, 1H, MOM), 4.66 (d,  $J$  = 6.6 Hz, 1H, MOM), 3.66 (dd,  $J$  = 9.0, 1.8 Hz, 1H, H-11), 3.60 (dt,  $J$  = 10.6, 2.0 Hz, 1H, H-12), 3.40 (s, 3H, MOM), 3.29 (s, 3H, OMe), 2.49 – 2.40 (m, 2H, H-10, H-14), 2.04 (ddd,  $J$  = 14.5, 10.6, 7.6 Hz, 1H, H-13), 1.77 (d,  $J$  = 2.5 Hz, 3H, Me-8), 1.51 (ddd,  $J$  = 14.5, 6.7, 2.2 Hz, 1H, H-13'), 1.25 (d,  $J$  = 6.8 Hz, 3H, Me-10), 1.10 (d,  $J$  = 6.9 Hz, 3H, Me-14) ppm;

$^{13}\text{C-NMR}$  (600 MHz,  $\text{CDCl}_3$ ,  $\text{CDCl}_3$  = 77.16 ppm):  $\delta$  204.8 (d, C-15), 97.5 (t, MOM), 81.6 (d, C-12), 80.3 (s, C-9), 78.9 (d, C-11), 78.5 (s, C-8), 56.8 (q, OMe), 56.2 (q, MOM), 44.5 (d, C-14), 31.5 (t, C-13), 28.8 (d, C-10), 18.8 (q, Me-10), 14.1 (q, Me-14), 3.6 (q, Me-8) ppm;

$[\alpha]_D^{27} = +14.7$  ( $c$  = 1.0,  $\text{CHCl}_3$ ).

**(2S,4S,5R,6S)-1-(3-(Diallylamino)-5-(methoxymethoxy)phenyl)-4-methoxy-5-(methoxymethoxy)-2,6-dimethylnon-7-yn-1-ol (356)**

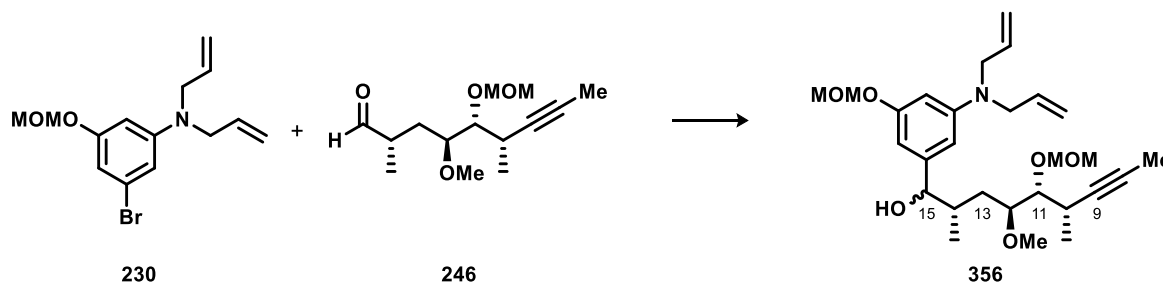

Aryl bromide **230** (117 mg, 0.375 mmol, 2.0 eq.) was dissolved in  $\text{Et}_2\text{O}$  (3.7 mL) and cooled to  $-78^\circ\text{C}$ .  $t\text{-BuLi}$  (1.69 M in pentane, 443  $\mu\text{L}$ , 0.749 mmol, 4.0 eq.) was added and stirring was continued for 45 min at  $-78^\circ\text{C}$  and 15 min at  $0^\circ\text{C}$ . Aldehyde **246** (48 mg, 0.187 mmol, 1.0 eq.) dissolved in  $\text{Et}_2\text{O}$  (1.8 mL) was added dropwise via syringe pump (1.2 mL/min). Stirring was continued for 2 h at  $-78^\circ\text{C}$ . The reaction was terminated by the addition of a saturated aqueous  $\text{NaHCO}_3$  solution. The phases were separated and the aqueous phase was extracted with  $\text{Et}_2\text{O}$  (3 x 10 mL). The combined organic phases were dried over  $\text{MgSO}_4$ , filtered and the solvent was removed under reduced pressure. The crude product was purified by flash column chromatography (PE/EtOAc = 6:1  $\rightarrow$  2:1) to yield a diastereomeric mixture of alcohol **356** (50 mg, 0.102 mmol, 55%,  $d.r.$  = 1:1.2) as a pale yellow oil.

$R_f$  = 0.2 (PE/EtOAc = 2:1);

$^1\text{H-NMR}$  (600 MHz,  $\text{CDCl}_3$ ,  $\text{CHCl}_3$  = 7.26 ppm):  $\delta$  6.38 – 6.39 (m, 2H,  $\text{H}_{\text{Ar}}$ ), 6.28 – 6.29 (m, 1H,  $\text{H}_{\text{Ar}}$ ), 5.85 – 5.83 (m, 2H, allyl), 5.18 – 5.11 (m, 6H, allyl, MOM), 4.82 (dd,  $J$  = 13.1, 6.6 Hz, 1H, MOM), 4.64 (dd,  $J$  = 10.2, 6.6 Hz, 1H, MOM), 4.58 (bs, 1H,  $\text{H-15}_{\text{major}}$ ), 4.20 (d,  $J$  = 7.8 Hz, 1H,  $\text{H-15}_{\text{minor}}$ ), 3.93 – 3.87 (m, 4H, allyl), 3.71 – 3.67 (m, 2H, H-11, H-12), 3.46 (s, 3H, MOM), 3.40 (s, 3H,  $\text{MOM}_{\text{minor}}$ ), 3.40 (s, 3H,  $\text{MOM}_{\text{major}}$ ), 3.38 (s, 3H,  $\text{OMe}_{\text{major}}$ ), 3.38 (s, 3H,  $\text{OMe}_{\text{minor}}$ ), 2.47 – 2.43 (m, 1H, H-10), 2.04 – 1.94 (m, 2H, H-14,  $\text{H-13}_{\text{minor}}$ ), 1.78 (d,  $J$  = 2.4 Hz, 3H,  $\text{Me-8}_{\text{major}}$ ), 1.76 (d,  $J$  = 2.4 Hz, 3H,  $\text{Me-8}_{\text{minor}}$ ), 1.71 – 1.67 (m, 1H,  $\text{H-13}_{\text{major}}$ ),

1.47 – 1.43 (m, 1H, H-13' major), 1.37 – 1.33 (m, 1H, H-13' minor), 1.26 (d,  $J = 3.1$  Hz, 3H, Me-10<sub>minor</sub>), 1.24 (d,  $J = 3.1$  Hz, 3H, Me-10<sub>major</sub>), 0.84 (d,  $J = 6.7$  Hz, 3H, Me-14<sub>major</sub>), 0.78 (d,  $J = 6.8$  Hz, 3H, Me-14<sub>minor</sub>) ppm;

<sup>13</sup>C-NMR (600 MHz, CDCl<sub>3</sub>, CDCl<sub>3</sub> = 77.16 ppm):  $\delta$  158.5 (s, C<sub>Ar</sub>, major), 158.4 (s, C<sub>Ar</sub>, minor), 149.9 (s, C<sub>Ar</sub>), 146.1 (s, C<sub>Ar</sub>, major), 145.7 (s, C<sub>Ar</sub>, minor), 134.1 (d, 2C, allyl), 116.2 (t, 2C, allyl), 105.6 (d, C<sub>Ar</sub>, minor), 104.8 (d, C<sub>Ar</sub>, major), 102.8 (d, C<sub>Ar</sub>, minor), 102.4 (d, C<sub>Ar</sub>, major), 100.2 (d, C<sub>Ar</sub>, minor), 99.8 (d, C<sub>Ar</sub>, major), 97.4 (t MOM), 94.8 (t, MOM), 82.0 (d, C-12), 80.7 (s, C-9), 80.4 (d, C-15<sub>minor</sub>), 79.2 (d, C-11), 79.0 (s, C-8), 78.1 (d, C-15<sub>major</sub>), 57.1 (q, MOM<sub>major</sub>), 57.0 (q, MOM<sub>minor</sub>), 56.2 (q, OMe<sub>minor</sub>), 56.2 (q, OMe<sub>major</sub>), 56.1 (q, MOM), 53.0 (t, 2C, allyl), 37.8 (d, C-14<sub>minor</sub>), 37.3 (d, C-14<sub>major</sub>), 33.5 (t, C-13<sub>major</sub>), 33.3 (t, C-13<sub>minor</sub>), 28.8 (d, C-10<sub>minor</sub>), 28.7 (d, C-10<sub>major</sub>), 18.7 (q, Me-10<sub>minor</sub>), 18.6 (q, Me-10<sub>major</sub>), 17.4 (q, Me-14<sub>minor</sub>), 14.3 (q, Me-14<sub>major</sub>), 3.6 (q, Me-8) ppm;

$[\alpha]_D^{25} = +5.4$  ( $c = 1.0$ , CHCl<sub>3</sub>);

HRMS-ESI  $m/z$  for C<sub>28</sub>H<sub>43</sub>NO<sub>6</sub>Na [M+Na]<sup>+</sup> calc. 512.2988, found 512.2985.

***O*-((2*S*,4*S*,5*R*,6*S*)-1-(3-(Diallylamino)-5-(methoxymethoxy)phenyl)-4-methoxy-5-(methoxymethoxy)-2,6-dimethylnon-7-yn-1-yl) *S*-methyl carbonodithioate (**357**)**

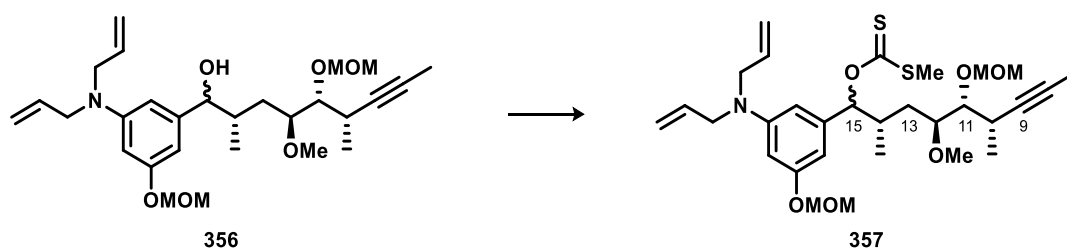

Benzylic alcohol **356** (50 mg, 0.102 mmol, 1.0 eq.) was dissolved in THF (1 mL) and NaHMDS (1 M in THF, 306  $\mu$ L, 0.306 mmol, 3.0 eq.) was added at room temperature. After stirring for 15 min, the mixture was cooled to 0 °C and CS<sub>2</sub> (31  $\mu$ L, 0.511 mmol, 5.0 eq.) was added and the resulting deep-orange turbid solution was stirred for 20 min. MeI (45  $\mu$ L, 0.715 mmol, 7.0 eq.) was added and the solution clarified immediately. After 20 min stirring at room temperature the mixture was diluted with MTBE and washed with a saturated aqueous NaH<sub>2</sub>PO<sub>4</sub> solution. The organic phase was dried over MgSO<sub>4</sub>, filtered and the solvent was removed under reduced pressure. The crude product was purified by flash column chromatography (PE/EtOAc = 6:1  $\rightarrow$  4:1) to yield a diastereomeric mixture of methylxanthate **357** (51 mg, 0.088 mmol, 90%) as a yellow oil.

$R_f = 0.5$  (PE/EtOAc = 2:1);

<sup>1</sup>H-NMR (600 MHz, CDCl<sub>3</sub>, CHCl<sub>3</sub> = 7.26 ppm):  $\delta$  6.40 (d,  $J = 5.3$  Hz, 1H, H-15<sub>minor</sub>), 6.39 – 6.30 (m, 3H, H<sub>Ar</sub>), 6.28 (d,  $J = 7.2$  Hz, 1H, H-15<sub>major</sub>), 5.86 – 5.81 (m, 2H, allyl), 5.18 (bs, 1H, allyl), 5.16 (bs, 2H, allyl), 5.14 (bs, 1H, allyl), 5.12 – 5.11 (m, 2H, MOM), 4.81 (d,  $J = 6.6$  Hz, 1H, MOM<sub>minor</sub>), 4.78 (d,  $J = 6.6$  Hz, 1H, MOM<sub>major</sub>), 4.64 (d,  $J = 6.6$  Hz, 1H, MOM<sub>minor</sub>), 4.61 (d,  $J = 6.6$  Hz, 1H, MOM<sub>major</sub>), 3.89 – 3.87 (m, 4H, allyl), 3.70 – 3.63 (m, 2H, H-11, H-12), 3.46 (s, 3H MOM), 3.39 (s, 3H MOM<sub>major</sub>), 3.37 (s, 3H, MOM<sub>major</sub>), 3.36 (s, 3H, OMe<sub>major</sub>), 3.34 (s, 3H, OMe<sub>minor</sub>), 2.55 (s, 3H, SMe<sub>major</sub>), 2.53 (s, 3H, SMe<sub>minor</sub>), 2.48 – 2.39 (m, 2H, H-10, H-14<sub>minor</sub>), 2.38 – 2.30 (m, 1H, H-14<sub>major</sub>), 1.92 – 1.86 (m, 1H, H-13<sub>minor</sub>),

1.77 (d,  $J = 2.4$  Hz, 3H, Me-8<sub>major</sub>), 1.76 (d,  $J = 2.4$  Hz, 3H, Me-8<sub>minor</sub>), 1.75 – 1.69 (m, 1H, H-13<sub>major</sub>), 1.36 (m, 1H, H-13'<sub>minor</sub>), 1.25 – 1.18 (m, 1H, H-13'<sub>major</sub>), 1.24 (d,  $J = 6.8$  Hz, 3H, Me-10<sub>minor</sub>), 1.23 (d,  $J = 6.8$  Hz, 3H, Me-10<sub>major</sub>), 0.99 (d,  $J = 6.8$  Hz, 3H, Me-14<sub>major</sub>), 0.88 (d,  $J = 6.8$  Hz, 3H, Me-14<sub>minor</sub>) ppm;

<sup>13</sup>C-NMR (600 MHz, CDCl<sub>3</sub>, CDCl<sub>3</sub> = 77.16 ppm):  $\delta$  214.9 (s, C(S)SMe), 158.5 (s, C<sub>Ar</sub>), 149.7 (s, C<sub>Ar</sub>), 140.4 (s, C<sub>Ar, major</sub>), 139.9 (s, C<sub>Ar, minor</sub>), 133.9 d, 2C, allyl), 116.4 (t, 2C, allyl), 106.6 (d, C<sub>Ar, minor</sub>), 105.6 (d, C<sub>Ar, major</sub>), 103.7 (d, C<sub>Ar, minor</sub>), 103.2 (d, C<sub>Ar, major</sub>), 100.4 (d, C<sub>Ar</sub>), 97.4 (t, MOM), 94.9 (t, MOM), 89.7 (d, C-15<sub>minor</sub>), 89.4 (d, C-15<sub>major</sub>), 80.7 (d, C-12), 79.4 (s, C-9), 79.2 (d, C-11), 78.1 (s, C-8), 57.2 (q, MOM), 57.1 (q, MOM), 56.2 (q, OMe<sub>minor</sub>), 56.1 (q, OMe<sub>major</sub>), 53.1 (t, 2C, allyl), 35.5 d, C-14<sub>major</sub>), 35.1 (d, C-14<sub>minor</sub>), 33.0 (t, C-13<sub>major</sub>), 32.1 (d, C-13<sub>minor</sub>), 28.6 (d, C-10<sub>minor</sub>), 28.5 (d, C-10<sub>major</sub>), 18.9 (q, MeS<sub>major</sub>), 18.9 (q, MeS<sub>minor</sub>), 18.6 (q, Me-10), 15.6 (q, Me-14<sub>minor</sub>), 14.5 (q, Me-10<sub>major</sub>), 3.6 (q, Me-8) ppm;

$[\alpha]_D^{26} = +5.0$  ( $c = 1.0$ , CHCl<sub>3</sub>);

HRMS-ESI  $m/z$  for C<sub>30</sub>H<sub>45</sub>NO<sub>6</sub>S<sub>2</sub>Na [M+Na]<sup>+</sup> calc. 602.2567, found 602.2568.

***N,N*-Diallyl-3-((2*R*,4*S*,5*R*,6*S*)-4-methoxy-5-(methoxymethoxy)-2,6-dimethylnon-7-yn-1-yl)-5-(methoxymethoxy)aniline (247)**

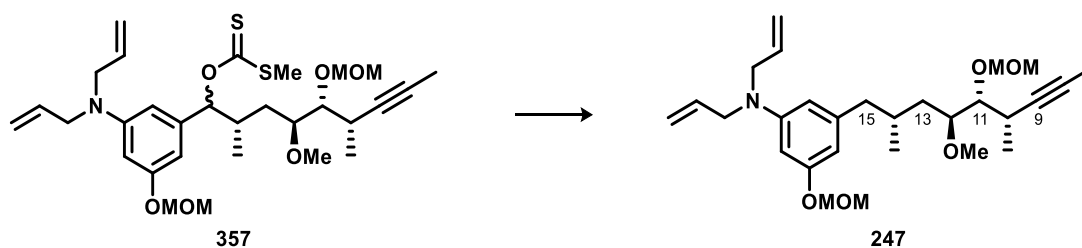

To a solution of methylxanthate **357** (40 mg, 0.070 mmol, 1.0 eq.) in PhMe (degassed in ultrasonic bath for 20 min, 0.7 mL) Bu<sub>3</sub>SnH (46  $\mu$ L, 0.172 mmol, 2.5 eq.) and Et<sub>3</sub>B (1 M in hexane, 14  $\mu$ L, 0.014 mmol, 0.2 eq.) was added. A needle was applied to the septum allowing air to enter the system and the mixture was stirred for 1 h at room temperature. The solvent was removed under reduced pressure and the crude product was purified by flash column chromatography (100% PE  $\rightarrow$  PE/EtOAc = 10:1) to yield compound **247** (31 mg, 0.056 mmol, 82%) as a pale-yellow oil.

$R_f = 0.6$  (PE/EtOAc = 2:1);

<sup>1</sup>H-NMR (600 MHz, CDCl<sub>3</sub>, CHCl<sub>3</sub> = 7.26 ppm):  $\delta$  6.24 (bs, 2H, H<sub>Ar</sub>), 6.21 (bs, 1H, H<sub>Ar</sub>), 5.87 – 5.82 (m, 2H, allyl), 5.18 (bs, 1H, allyl), 5.15 (bs, 2H, allyl), 5.13 (bs, 1H, allyl), 5.12 (s, 2H, MOM), 4.83 (d,  $J = 6.6$  Hz, 1H, MOM), 4.66 (d,  $J = 6.6$  Hz, 1H, MOM), 3.88 (d,  $J = 3.4$  Hz, 4H, allyl), 3.69 – 3.66 (m, 2H, H-11, H-12), 3.47 (s, 3H, MOM), 3.40 (s, 3H, MOM), 3.37 (s, 3H, OMe), 2.64 (dd,  $J = 13.3, 5.4$  Hz, 1H, H-15), 2.49 – 2.43 (m, 1H, H-10), 2.25 (dd,  $J = 13.2, 9.3$  Hz, 1H, H-15'), 2.01 – 1.95 (m, 1H, H-14), 1.77 (d,  $J = 2.4$  Hz, 3H, Me-8), 1.71 (ddd,  $J = 14.2, 10.4, 3.7$  Hz, 1H, H-13), 1.30 – 1.26 (m, 1H, H-13'), 1.25 (d,  $J = 6.8$  Hz, 3H, Me-10), 0.86 (d,  $J = 6.5$  Hz, 3H, Me-14) ppm;

<sup>13</sup>C-NMR (600 MHz, CDCl<sub>3</sub>, CDCl<sub>3</sub> = 77.16 ppm):  $\delta$  158.4 (s, C<sub>Ar</sub>), 149.9 (s, C<sub>Ar</sub>), 143.4 (s, C<sub>Ar</sub>), 134.3 (d, 2C, allyl), 116.2 (t, 2C, allyl), 107.8 (d, C<sub>Ar</sub>), 105.3 (d, C<sub>Ar</sub>), 98.8 (d, C<sub>Ar</sub>), 97.5 (t, MOM), 94.7 (t, MOM), 81.2 (d, C-12), 80.8 (s, C-9), 79.7 (d, C-11), 78.0 (s, C-8), 57.2 (q,

OMe), 56.2 (q, MOM), 56.1 (q, MOM), 52.9 (t, 2C, allyl), 45.3 (t, C-15), 37.0 (t, C-13), 31.2 (d, C-14), 28.6 (d, C-10), 18.8 (q, Me-14), 18.7 (q, Me-10), 3.6 (q, Me-8) ppm;  
 $[\alpha]_D^{22} = -14.1$  ( $c = 1.0$ ,  $\text{CHCl}_3$ );  
**HRMS-ESI**  $m/z$  for  $\text{C}_{28}\text{H}_{43}\text{NO}_5\text{Na}$   $[\text{M}+\text{Na}]^+$  calc. 496.3039, found 496.3037.

**(((4*S*,5*R*,6*S*,8*S*)-9-Bromo-6-methoxy-4,8-dimethylnon-2-yn-5-yl)oxy)(*tert*-butyl)dimethylsilane (186)**

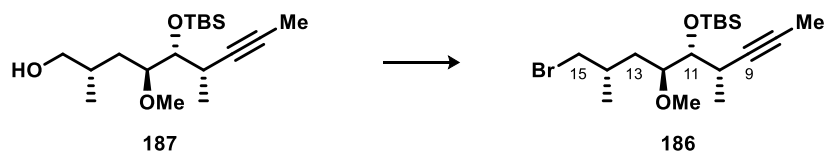

Alcohol **187** (42 mg, 0.127 mmol, 1.0 eq.) was dissolved in  $\text{CH}_2\text{Cl}_2$  (0.5 mL).  $\text{CBr}_4$  (50 mg, 0.152 mmol, 1.2 eq.) and imidazole (13 mg, 0.190 mmol, 1.5 eq.) were added and the mixture was cooled to 0 °C before  $\text{PPh}_3$  (66 mg, 0.253 mmol, 2.0 eq.) was added. The mixture was stirred at this temperature for 5 min and was then stirred at 40 °C for 6 h. The solvent was removed under reduced pressure and the slurry residue was dissolved in acetone (dry, reagent grade). Two spatula tips<sup>20</sup> of  $\text{CuCl}$  were added and stirring was continued at room temperature for 30 min. The precipitate was allowed to settle for 5 min and the supernatant was filtered through a plug of silica. The solvent was removed under reduced pressure and the crude product was purified by flash column chromatography (PE/EtOAc = 10:1) to yield bromide **186** (33 mg, 84.8  $\mu\text{mol}$ , 67%) as a colorless oil.

$R_f = 0.4$  (PE/EtOAc = 6:1);

$^1\text{H-NMR}$  (400 MHz,  $\text{CDCl}_3$ ,  $\text{CHCl}_3 = 7.26$  ppm):  $\delta$  3.65 (dd,  $J = 8.9, 1.7$  Hz, 1H, H-11), 3.55 (dt,  $J = 10.3, 2.0$  Hz, 1H, H-12), 3.46 (dd,  $J = 9.7, 4.9$  Hz, 1H, H-15), 3.34 (s, 3H, OMe), 3.32 (dd,  $J = 9.6, 4.4$  Hz, 1H, H-15'), 2.36 – 2.31 (m, 1H, H-10), 2.07 – 2.00 (m, 1H, H-14), 1.78 (d,  $J = 2.4$  Hz, 3H, Me-8), 1.69 (ddd,  $J = 14.3, 10.4, 3.9$  Hz, 1H, H-13), 1.26 (ddd,  $J = 14.4, 9.5, 2.3$  Hz, 1H, H-13'), 1.18 (d,  $J = 6.9$  Hz, 3H, Me-10), 1.05 (d,  $J = 6.6$  Hz, 3H, Me-14), 0.89 (s, 9H, TBS), 0.08 (s, 3H, TBS), 0.06 (s, 3H, TBS) ppm;

$[\alpha]_D^{21} = -21.0$  ( $c = 1.0$ ,  $\text{CH}_2\text{Cl}_2$ );

**HRMS-ESI**  $m/z$  for  $\text{C}_{18}\text{H}_{35}\text{BrO}_2\text{SiNa}$   $[\text{M}+\text{Na}]^+$  calc. 413.1488, found 413.1487.

<sup>20</sup> The amount of  $\text{CuCl}$  was increased if necessary, until no more  $\text{PPh}_3$  was detected by TLC.



## 5.4.2 Arenes

### 3-Bromo-5-nitrophenol (**181**)

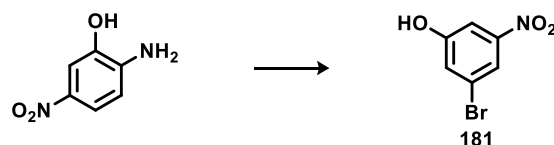

According to a procedure by Brooks *et al.*<sup>[152]</sup> 2-amino-5-nitrophenol (1.20 g, 7.77 mmol, 1.0 eq.) and NBS (1.45 g, 8.16 mmol, 1.05 eq.) were dissolved in acetonitrile (wet, 50 mL) stirred for 1 h at room temperature and then concentrated under reduced pressure. The brown residue was dissolved in EtOH (wet, non-denatured, 25 mL) and H<sub>2</sub>SO<sub>4</sub> (conc., 0.70 mL, 13.20 mmol, 1.7 eq.) was added. The mixture was stirred under refluxing conditions for 30 min before sodium nitrite (1.34 g, 19.43 mmol, 2.5 eq.) was added. The mixture was stirred for 1 h under refluxing conditions and was concentrated under reduced pressure. The residue was partitioned between water and EtOAc and the phases were separated. The organic phase was washed with water, saturated aqueous NaHCO<sub>3</sub> solution and brine, dried over MgSO<sub>4</sub>, filtered and the solvent was removed under reduced pressure. The crude product was purified by flash column chromatography (PE/EtOAc = 4:1 → 1:1) to yield 3-bromo-5-nitrophenol (**181**, 986 mg, 4.52 mmol, 58%) as a brown solid.

The analytical data are consistent with those reported in the literature.<sup>[209,210]</sup>

**R<sub>f</sub>** = 0.5 (PE/EtOAc = 2:1);

**<sup>1</sup>H-NMR** (400 MHz, DMSO-d<sub>6</sub>, DMSO-d<sub>5</sub> = 2.50 ppm): δ 10.93 (s, 1H, OH), 7.79 (s, 1H, H<sub>Ar</sub>), 7.54 (s, 1H, H<sub>Ar</sub>), 7.39 (s, 1H, H<sub>Ar</sub>) ppm;

**m.p.** 156 °C (lit. 155 – 157 °C)<sup>[209]</sup>;

**HRMS-ESI** *m/z* not found.

### 1-(Benzyloxy)-3-bromo-5-nitrobenzene (**236**)

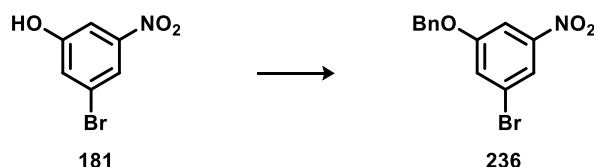

3-Bromo-5-nitrophenol (**181**, 1.33 g, 6.11 mmol, 1.0 eq.) was dissolved in acetone (20 mL). K<sub>2</sub>CO<sub>3</sub> (2.54 g, 9.17 mmol, 3.0 eq.) was added, followed by benzyl bromide (1.11 mL, 9.17 mmol, 1.5 eq.). The suspension was stirred at 70 °C for 6 h before it was filtered, diluted with MTBE and washed with water. The aqueous phase was extracted with MTBE (3 x 10 mL). The combined organic phases were dried over MgSO<sub>4</sub>, filtered and the solvent was removed under reduced pressure. The crude product was purified by flash column chromatography (PE/EtOAc = 10:1 → 4:1) to yield nitro arene **236** (1.60 g, 5.18 mmol, 85%) as a yellow sticky gum.

The analytical data are consistent with those reported in the literature.<sup>[211]</sup>

**R<sub>f</sub>** = 0.6 (PE/EtOAc = 4:1);

**<sup>1</sup>H-NMR** (400 MHz, CDCl<sub>3</sub>, CHCl<sub>3</sub> = 7.26 ppm):  $\delta$  7.98 (t,  $J$  = 1.8 Hz, 1H, H<sub>Ar</sub>), 7.76 (t,  $J$  = 2.2 Hz, 1H, H<sub>Ar</sub>), 7.45 – 7.44 (m, 1H, H<sub>Ar</sub>), 7.43 – 7.37 (m, 5H, Bn), 5.13 (s, 2H, Bn) ppm;

**HRMS-ESI**  $m/z$  not found.

### 3-(Benzyloxy)-5-bromoaniline (**237**)

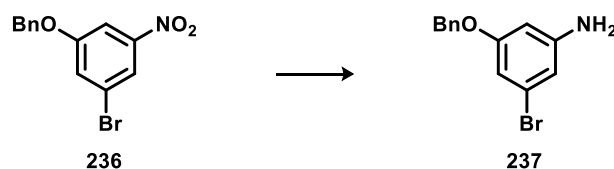

Nitro arene **236** (1.06 g, 3.43 mmol, 1.0 eq.) was dissolved in THF/EtOH (1:1, 12 mL) and SnCl<sub>2</sub>·2H<sub>2</sub>O (3.95 g, 17.15 mmol, 5.0 eq.) was added in one portion. The mixture was stirred at room temperature for 4 h before the solvent was removed under reduced pressure to afford a brown oil to which an aqueous 10% NaOH solution was added and stirred for 30 min. The resulting suspension was extracted with MTBE (3 x 10 mL), dried over MgSO<sub>4</sub>, filtered and the solvent was removed under reduced pressure. Aniline **237** was obtained as a yellow gum and was used in the next step without further purification.

$R_f$  = 0.2 (PE/EtOAc = 4:1);

**<sup>1</sup>H-NMR** (400 MHz, DMSO-*d*<sub>6</sub>, DMSO = 2.50 ppm):  $\delta$  7.41 – 7.30 (m, 5H, Bn), 6.38 (app. t,  $J$  = 1.7 Hz, 1H, H<sub>Ar</sub>), 6.36 (app. t,  $J$  = 1.8 Hz, 1H, H<sub>Ar</sub>), 6.21 (app. t,  $J$  = 1.9 Hz, 1H, H<sub>Ar</sub>), 4.99 (s, 2H, Bn), 4.00 (bs, 3H, NH<sub>2</sub> protonated) ppm;

**<sup>13</sup>C-NMR** (400 MHz, CDCl<sub>3</sub>, CDCl<sub>3</sub> = 77.16 ppm):  $\delta$  160.1 (s, C-3), 150.5 (s, C-1), 136.9 (s, Bn), 128.5 (d, 2C, Bn), 127.8 (d, Bn), 127.6 (d, 2C, Bn), 122.3 (s, C-5), 109.8 (d, C<sub>Ar</sub>), 105.6 (d, C<sub>Ar</sub>), 99.6 (d, C<sub>Ar</sub>) ppm;

**m.p.** 120 – 123 °C;

**HRMS-ESI**  $m/z$  for C<sub>13</sub>H<sub>12</sub>BrNO [M+H]<sup>+</sup> calc. 278.0181, found 278.0183.

### *N,N*-Diallyl-3-(benzyloxy)-5-bromoaniline (**233**)

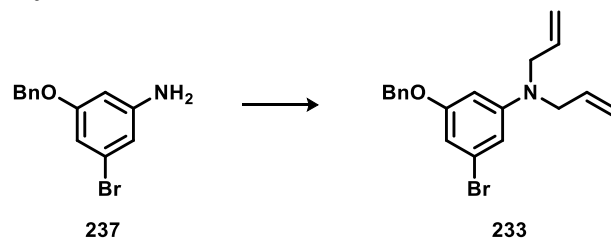

Aniline **237** (583 mg, 2.10 mmol, 1.0 eq.) was dissolved in DMF (10 mL) and K<sub>2</sub>CO<sub>3</sub> (1.74 g, 12.58 mmol, 6.0 eq.) was added, followed by allyl bromide (1.81 mL, 20.96 mmol, 10.0 eq.). The suspension was stirred at 60 °C for 6 h before it was filtered, diluted with MTBE (30 mL) and washed with water (5 x 15 mL). The organic phase was dried over MgSO<sub>4</sub>, filtered and the solvent was removed under reduced pressure. Residual allyl bromide was removed under high vacuum for 48 h. The crude product was purified by flash column chromatography

(PE/EtOAc = 20:1 → 8:1) to yield protected aniline **233** (632 mg, 1.78 mmol, 77% o2s) as a yellow oil.

$R_f$  = 0.5 (PE/EtOAc = 4:1);

**$^1\text{H-NMR}$**  (400 MHz,  $\text{CDCl}_3$ ,  $\text{CHCl}_3$  = 7.26 ppm):  $\delta$  7.34 – 7.30 (m, 5H, Bn), 6.49 (app. t,  $J$  = 1.79 Hz, 1H,  $\text{H}_{\text{Ar}}$ ), 6.47 (app. t,  $J$  = 1.89 Hz, 1H,  $\text{H}_{\text{Ar}}$ ), 6.23 (app. t,  $J$  = 2.31 Hz, 1H,  $\text{H}_{\text{Ar}}$ ), 5.85 – 5.76 (m, 2H, allyl), 5.17 – 5.16 (m, 2H, allyl), 5.15 – 5.14 (m, 1H, allyl), 5.13 – 5.12 (m, 1H, allyl), 4.99 (s, 2H, Bn), 3.87 – 3.85 (m, 4H, allyl) ppm;

**$^{13}\text{C-NMR}$**  (400 MHz,  $\text{CDCl}_3$ ,  $\text{CDCl}_3$  = 77.16 ppm):  $\delta$  160.5 (s, C-3), 136.9 (s, Bn), 133.2 (d, 2C, allyl), 128.7 (d, 2C, Bn), 128.2 (d, Bn), 127.7 (d, 2C, Bn), 123.6 (s, 2C, C-1, C-5), 116.6 (t, 2C, allyl), 109.0 (d,  $\text{C}_{\text{Ar}}$ ), 106.1 (d,  $\text{C}_{\text{Ar}}$ ), 98.7 (d,  $\text{C}_{\text{Ar}}$ ), 70.3 (t, Bn), 53.0 (t, allyl) ppm;

**HRMS-ESI**  $m/z$  for  $\text{C}_{19}\text{H}_{20}\text{BrNONa} [\text{M}+\text{Na}]^+$  calc. 380.0626, found 380.0621.

### 3-Amino-5-bromophenol (**182**)

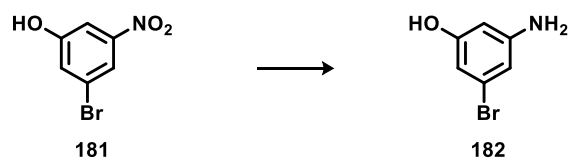

3-Bromo-5-nitrophenol (**181**, 986 mg, 4.52 mmol, 1.0 eq.), was dissolved in EtOH (15 mL) and AcOH (15 mL) and iron powder (1.01 g, 18.08 mmol, 4.0 eq.) were added. After stirring for 2 h under refluxing conditions, the mixture was slowly warmed up to room temperature, was diluted with water (50 mL) and neutralized with solid  $\text{Na}_2\text{CO}_3$ . The mixture was extracted with  $\text{Et}_2\text{O}$  (4 x 30 mL) and the combined organic phases were washed with brine, dried over  $\text{MgSO}_4$ , filtered and the solvent was removed under reduced pressure. The crude product was purified by flash column chromatography (PE/EtOAc = 20:1 → 2:1) to yield 3-amino-5-bromophenol (**182**, 691 mg, 3.68 mmol, 81%) as a pale yellow oil.

The analytical data are consistent with those reported in the literature.<sup>[152]</sup>

**$^1\text{H-NMR}$**  (400 MHz,  $\text{DMSO-d}_6$ ,  $\text{DMSO-d}_5$  = 2.50 ppm):  $\delta$  9.29 (s, 1H, OH), 6.18 (s, 1H,  $\text{H}_{\text{Ar}}$ ), 6.06 (s, 1H,  $\text{H}_{\text{Ar}}$ ), 5.95 (s, 1H,  $\text{H}_{\text{Ar}}$ ), 5.24 (bs, 2H,  $\text{NH}_2$ ) ppm;

**GCMS** [EI] calc. 186.9633 found 187.0.

### *tert*-Butyl (3-bromo-5-hydroxyphenyl)carbamate (**183**)

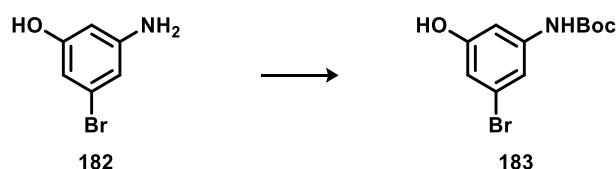

According to the procedure published by Shinde *et al.*<sup>[153]</sup> 3-amino-5-bromophenol (**182**, 2.51 g, 13.35 mmol, 1.0 eq.) was dissolved in glycerol (20 mL) and  $\text{Boc}_2\text{O}$  (2.91 g, 13.35 mmol, 1.0 eq.) was added. After stirring was continued at room temperature for 18 h, water (20 mL) was added. The phases were separated and the aqueous phase was extracted with EtOAc (20 mL) until the organic phase remained clear. The combined organic phases

were dried over  $\text{MgSO}_4$ , filtered and the solvent was removed under reduced pressure to yield carbamate **183** (3.85 g, 13.35 mmol, *quant.*) as a red-purple oil which was used in the next step without further purification.

$R_f = 0.5$  (PE/EtOAc = 2:1);

$^1\text{H-NMR}$  (400 MHz,  $\text{CDCl}_3$ ,  $\text{CHCl}_3 = 7.26$  ppm):  $\delta$  7.00 (s, 2H,  $\text{H}_{\text{Ar}}$ , NH), 6.69 (t,  $J = X.X$  Hz, 1H,  $\text{H}_{\text{Ar}}$ ), 6.45 (s, 1H,  $\text{H}_{\text{Ar}}$ ), 5.44 (bs, 1H, OH), 1.51 (s, 9H, Boc) ppm;

**HRMS-ESI**  $m/z$  for  $\text{C}_{11}\text{H}_{14}\text{BrNO}_3\text{Na}$   $[\text{M}+\text{Na}]^+$  calc. 310.0055, found 310.0055.

### 3-Bromo-5-((*tert*-butyldimethylsilyl)oxy)aniline (**184**)

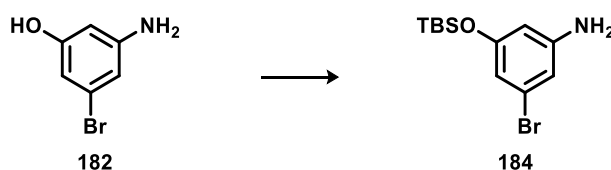

3-Amino-5-bromophenol **182** (56 mg, 0.298 mmol, 1.0 eq.) was dissolved in  $\text{CH}_2\text{Cl}_2$  (2 mL) and TBSCl (51 mg, 0.328 mmol, 1.1 eq.) and imidazole (22 mg, 30.328 mmol, 1.1 eq.) were added. Stirring was continued at room temperature for 48 h. The reaction was terminated by the addition of water. The phases were separated and the aqueous phase was extracted with  $\text{CH}_2\text{Cl}_2$  (3 x 5 mL). The combined organic phases were dried over  $\text{MgSO}_4$ , filtered and the solvent was removed under reduced pressure. The crude product was purified by flash column chromatography (PE/EtOAc = 6:1  $\rightarrow$  2:1) to yield arene **184** (67 mg, 0.223 mmol, 75%) as a pale-yellow oil.

$R_f = 0.5$  (PE/EtOAc = 4:1);

$^1\text{H-NMR}$  (400 MHz,  $\text{CDCl}_3$ ,  $\text{CHCl}_3 = 7.26$  ppm):  $\delta$  6.55 (s, 1H,  $\text{H}_{\text{Ar}}$ ), 6.47 (s, 1H,  $\text{H}_{\text{Ar}}$ ), 6.18 (s, 1H,  $\text{H}_{\text{Ar}}$ ), 4.77 (bs, 2H,  $\text{NH}_2$ ), 0.96 (s, 9H, TBS), 0.19 (s, 6H, TBS) ppm;

**HRMS-ESI**  $m/z$  for  $\text{C}_{12}\text{H}_{20}\text{BrNOSiNa}$   $[\text{M}+\text{Na}]^+$  calc. 324.0396, found 324.0392.

### *N*-(3-Bromo-5-((*tert*-butyldimethylsilyl)oxy)phenyl)acetamide (**178**)

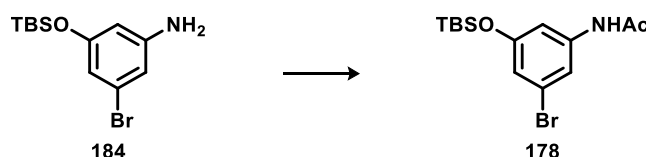

Aniline **184** (90 mg, 0.298 mmol, 1.0 eq.) was dissolved in  $\text{CH}_2\text{Cl}_2$  (2 mL) and  $\text{Ac}_2\text{O}$  (56  $\mu\text{L}$ , 0.596 mmol, 2.0 eq.) and pyridine (72  $\mu\text{L}$ , 0.893 mmol, 3.0 eq.) were added. The mixture was stirred at room temperature for 30 min. The reaction was terminated by the addition of water and diluted with  $\text{CH}_2\text{Cl}_2$  (10 mL). The phases were separated and the organic phase was washed with an aqueous 1M HCl solution and brine, dried over  $\text{MgSO}_4$ , filtered and the solvent was removed under reduced pressure. The crude product was purified by flash column chromatography (PE/EtOAc = 4:1) to yield acetamide **178** (92 mg, 0.267 mmol, 90%) as a pale orange solid.

$R_f = 0.3$  (PE/EtOAc = 2:1);

**<sup>1</sup>H-NMR** (400 MHz, CDCl<sub>3</sub>, CHCl<sub>3</sub> = 7.26 ppm): δ 7.23 (s, 1H, H<sub>Ar</sub>), 7.10 (bs, 2H, H<sub>Ar</sub>, NH), 6.75 (s, 1H, H<sub>Ar</sub>), 2.16 (s, 3H, Ac), 0.97 (s, 9H, TBS), 0.21 (s, 6H, TBS) ppm;

**m.p.** 91-93 °C;

**HRMS-ESI** *m/z* for C<sub>14</sub>H<sub>22</sub>BrNO<sub>2</sub>SiNa [M+Na]<sup>+</sup> calc. 366.0501, found 366.0501.

***tert*-Butyl (3-bromo-5-((*tert*-butyldimethylsilyloxy)phenyl)carbamate (176)**

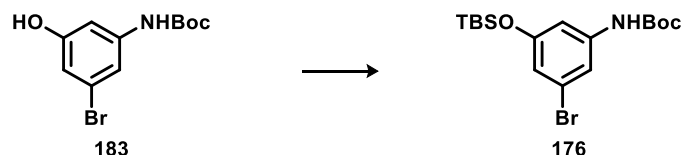

Phenol **183** (904 mg, 3.14 mmol, 1.0 eq.) was dissolved in CH<sub>2</sub>Cl<sub>2</sub> (10 mL) and TBSCl (536 mg, 3.45 mmol, 1.1 eq.) and imidazole (235 mg, 3.45 mmol, 1.1 eq.) were added. Stirring was continued at room temperature for 2 h. The reaction was terminated by the addition of water. The phases were separated and the aqueous phase was extracted with CH<sub>2</sub>Cl<sub>2</sub> (3 x 10 mL). The combined organic phases were dried over MgSO<sub>4</sub>, filtered and the solvent was removed under reduced pressure. The crude product was purified by flash column chromatography (PE/EtOAc = 8:1 → 6:1) to yield arene **176** (949 mg, 2.36 mmol, 75%) as a beige gum.

**R<sub>f</sub>** = 0.6 (PE/EtOAc = 4:1);

**<sup>1</sup>H-NMR** (400 MHz, CDCl<sub>3</sub>, CHCl<sub>3</sub> = 7.26 ppm): δ 7.23 (s, 1H, H<sub>Ar</sub>), 6.77 (t, *J* = 1.9 Hz, 1H, H<sub>Ar</sub>), 6.67 (t, *J* = 1.9 Hz, 1H, H<sub>Ar</sub>), 6.37 (s, 1H, NH), 1.51 (s, 9H, Boc), 0.97 (s, 9H, TBS), 0.20 (s, 6H, TBS) ppm;

**<sup>13</sup>C-NMR** (400 MHz, CDCl<sub>3</sub>, CDCl<sub>3</sub> = 77.16 ppm): δ 157.0 (s, C-5), 152.3 (s, Boc), 140.5 (s, C-1), 122.7 (s, C-3), 118.1 (d, C<sub>Ar</sub>), 114.7 (d, C<sub>Ar</sub>), 109.1 (d, C<sub>Ar</sub>), 81.1 (s, Boc), 28.4 (s, TBS), 25.7 (q, 3C, Boc), 18.3 (q, 3C, TBS), -4.3 (q, 2C, TBS) ppm;

**HRMS-ESI** *m/z* for C<sub>17</sub>H<sub>28</sub>BrNO<sub>3</sub>SiNa [M+Na]<sup>+</sup> calc. 424.0920, found 424.0919.

***tert*-Butyl (3-(benzyloxy)-5-bromophenyl)carbamate (177)**

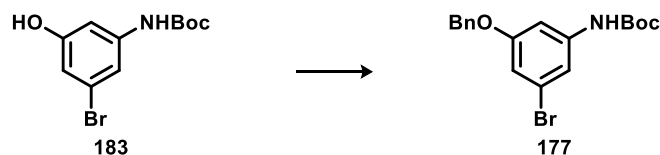

Phenol **183** (926 mg, 3.21 mmol, 1.0 eq.), K<sub>2</sub>CO<sub>3</sub> (577 mg, 4.18 mmol, 1.3 eq.) and benzylbromide (506 μL, 4.18 mmol, 1.3 eq.) were dissolved in acetone (6 mL) and stirred at 70 °C for 48 h. The reaction mixture was filtered, concentrated under reduced pressure and purified by flash column chromatography (PE/EtOAc = 10:1 → 6:1) to yield compound **177** (1.13 g, 3.0 mmol, 93%) as a yellow oil which was of sufficient purity to be used in the next step.

**R<sub>f</sub>** = 0.5 (PE/EtOAc = 4:1);

**<sup>1</sup>H-NMR** (400 MHz, CDCl<sub>3</sub>, CHCl<sub>3</sub> = 7.26 ppm):  $\delta$  7.38 – 7.30 (m, 5H, Bn), 7.14 (t,  $J$  = 1.7 Hz, 1H, H<sub>Ar</sub>), 7.04 (t,  $J$  = 1.8 Hz, 1H, H<sub>Ar</sub>), 6.82 (t,  $J$  = 1.9 Hz, 1H, H<sub>Ar</sub>), 6.44 (bs, 1H, NH), 5.02 (s, 2H, Bn), 1.51 (s, 9H, Boc) ppm;

**<sup>13</sup>C-NMR** (400 MHz, CDCl<sub>3</sub>, CDCl<sub>3</sub> = 77.16 ppm):  $\delta$  160.1 (s, C-3), 152.4 (s, Boc), 140.6 (s, C-1), 136.5 (s, Bn), 128.8 (d, 2C, Bn), 128.7 (s, C-5), 128.3 (d, Bn), 127.7 (d, 2C, Bn), 127.7 (d, C<sub>Ar</sub>), 123.0 (d, C<sub>Ar</sub>), 113.0 (d, C<sub>Ar</sub>), 81.2 (s, Boc), 70.4 (t, Bn), 28.4 (q, 3C, Boc) ppm;

**HRMS-ESI**  $m/z$  for C<sub>18</sub>H<sub>20</sub>BrNO<sub>3</sub>Na [M+Na]<sup>+</sup> calc. 400.0524, found 400.0524.

### *N,N*-Diallyl-3-(allyloxy)-5-bromoaniline (**218**)

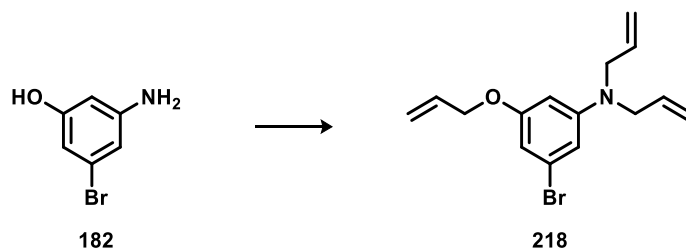

3-Amino-5-bromophenol (**182**, 115 mg, 0.612 mmol, 1.0 eq.) was dissolved in MeCN (3 mL). K<sub>2</sub>CO<sub>3</sub> (845 mg, 6.12 mmol, 10.0 eq) was added and the mixture was stirred at 60 °C for 5 min. Allyl bromide (530  $\mu$ L, 6.12 mmol, 10.0 eq.) as a solution in MeCN (3 mL) was added slowly and the reaction was heated to 80 °C and stirred overnight. After cooling to room temperature the mixture was filtered and the solvent was removed under reduced pressure. The crude oil was subjected to high vacuum overnight to remove excess allyl bromide. Arene **218** (166 mg, 0.539 mmol, 88%) was obtained as a pale-yellow oil and was of sufficient purity to be used in the next step without further purification.

$R_f$  = 0.7 (PE/EtOAc = 4:1);

**<sup>1</sup>H-NMR** (400 MHz, CDCl<sub>3</sub>, CHCl<sub>3</sub> = 7.26 ppm):  $\delta$  6.46 (t,  $J$  = 1.8 Hz, 1H, H<sub>Ar</sub>), 6.41 (t,  $J$  = 1.7 Hz, 1H, H<sub>Ar</sub>), 6.19 (bs, 1H, H<sub>Ar</sub>), 6.02 (ddt,  $J$  = 17.3, 10.6, 5.3 Hz, 1H, O-allyl), 5.82 (ddt,  $J$  = 17.1, 10.1, 5.1 Hz, 2H, N(allyl)<sub>2</sub>), 5.39 (dq,  $J$  = 17.3, 1.6 Hz, 1H, O-allyl), 5.27 (dq,  $J$  = 10.5, 1.4 Hz, 1H, O-allyl), 5.18 (dq,  $J$  = 1.8 Hz, 2H, N(allyl)<sub>2</sub>), 5.15 (dq,  $J$  = 9.4, 1.5 Hz, 2H, N(allyl)<sub>2</sub>), 4.47 (dt,  $J$  = 5.4, 1.5 Hz, 2H, O-allyl), 3.88 – 3.86 (m, 4H, N(allyl)<sub>2</sub>) ppm;

**<sup>13</sup>C-NMR** (400 MHz, CDCl<sub>3</sub>, CDCl<sub>3</sub> = 77.16 ppm):  $\delta$  160.3 (s, C-3), 133.2 (d, 3C, allyl), 123.5 (s, 2C, C-1, C-5), 118.0 (t, 3C, allyl), 116.6 (d, C<sub>Ar</sub>), 108.9 (d, C<sub>Ar</sub>), 98.9 (d, C<sub>Ar</sub>), 69.1 (t, O-allyl), 53.0 (t, N(allyl)<sub>2</sub>) ppm;

**GCMS**  $m/z$  for C<sub>15</sub>H<sub>18</sub>BrNO [M=307.0572]: 307.1 (M), 266.0 (M-C<sub>3</sub>H<sub>5</sub><sup>•</sup>), 228.1 (M-Br<sup>•</sup>), 41.1 (C<sub>3</sub>H<sub>5</sub><sup>•</sup>).

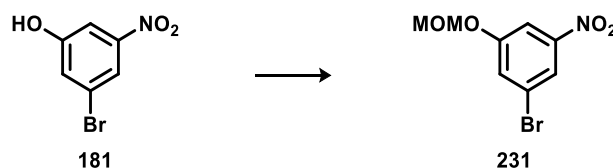
**1-Bromo-3-(methoxymethoxy)-5-nitrobenzene (231)**

3-Bromo-5-nitrophenol (**181**, 2.0 g, 9.17 mmol, 1.0 eq.) was dissolved in DMF (23 mL) and cooled to 0 °C. Sodium hydride (60% dispersion in mineral oil, 734 mg, 18.35 mmol, 2.0 eq.) was added in portions and stirring was continued for 30 min. Then, MOMCl (1.4 mL, 18.35 mmol, 2.0 eq.) was added dropwise and the reaction was allowed to reach room temperature. Stirring was continued for 1.5 h and the mixture was poured into water. The phases were separated and the aqueous phase was extracted with MTBE (3 x 50 mL). The combined organic phases were dried over MgSO<sub>4</sub>, filtered and the solvent was removed under reduced pressure to yield MOM ether **231** as an orange oil which was used in the next step without further purification.

$R_f = 0.6$  (PE/EtOAc = 2:1);

<sup>1</sup>H-NMR (400 MHz, CDCl<sub>3</sub>, CHCl<sub>3</sub> = 7.26 ppm):  $\delta$  7.97 – 7.96 (m, 1H, H<sub>Ar</sub>), 7.80 – 7.79 (m, 1H, H<sub>Ar</sub>), 7.49 – 7.48 (m, 1H, H<sub>Ar</sub>), 5.21 (s, 2H, MOM), 3.47 (s, 3H, MOM) ppm;

<sup>13</sup>C-NMR (400 MHz, CDCl<sub>3</sub>, CDCl<sub>3</sub> = 77.16 ppm):  $\delta$  158.3 (s, C-3), 149.5 (s, C-5), 125.6 (d, C<sub>Ar</sub>), 123.0 (s, C-1), 119.9 (d, C<sub>Ar</sub>), 110.4 (d, C<sub>Ar</sub>), 94.8 (t, MOM), 56.6 (q, MOM) ppm;

HRMS-ESI  $m/z$  not found.

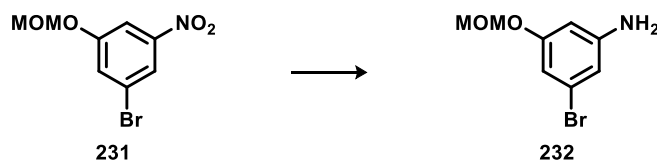
**3-Bromo-5-(methoxymethoxy)aniline (232)**

Crude nitro arene **231** (9.17 mmol, 1.0 eq.) was dissolved in THF/EtOH (1:1, 23 mL) at room temperature and SnCl<sub>2</sub>·2H<sub>2</sub>O (6.3 g, 27.51 mmol, 3.0 eq.) was added in one portion. The mixture was stirred for 4 h before the solvent was removed under reduced pressure to afford a brown oil to which an aqueous 10% NaOH solution was added and stirred for 30 min. The resulting suspension was extracted with MTBE (3 x 30 mL), dried over MgSO<sub>4</sub>, filtered and the solvent was removed under reduced pressure. Crude aniline **232** was obtained as a brown oil, which was used in the next step without further purification.

$R_f = 0.3$  (PE/EtOAc = 2:1);

<sup>1</sup>H-NMR (400 MHz, CDCl<sub>3</sub>, CHCl<sub>3</sub> = 7.26 ppm):  $\delta$  6.60 (t,  $J = 1.9$  Hz, 1H, H<sub>Ar</sub>), 6.49 (t,  $J = 1.8$  Hz, 1H, H<sub>Ar</sub>), 6.28 (t,  $J = 2.1$  Hz, 1H, H<sub>Ar</sub>), 5.10 (s, 2H, MOM), 3.46 (s, 3H, MOM) ppm;

<sup>13</sup>C-NMR (400 MHz, CDCl<sub>3</sub>, CDCl<sub>3</sub> = 77.16 ppm):  $\delta$  158.9 (s, C-5), 148.6 (s, C-1), 123.2 (s, C-3), 111.8 (d, C<sub>Ar</sub>), 109.8 (d, C<sub>Ar</sub>), 101.7 (d, C<sub>Ar</sub>), 94.4 (t, MOM), 56.1 (q, MOM) ppm;

HRMS-ESI  $m/z$  for C<sub>8</sub>H<sub>11</sub>BrNO<sub>2</sub> [M+H]<sup>+</sup> calc. 231.9973, found 231.9970.

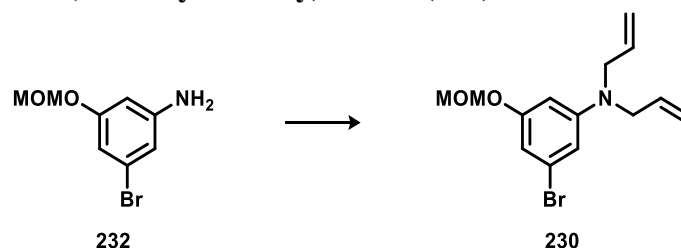
***N,N*-Diallyl-3-bromo-5-(methoxymethoxy)aniline (230)**

Crude aniline **232** (9.17 mmol, 1.0 eq.) was dissolved in DMF (36 mL) and  $K_2CO_3$  (6.3 g, 45.87 mmol, 5.0 eq.) was added followed by allyl bromide (6.3 mL, 73.39 mmol, 8.0 eq.). The mixture was heated to 70 °C and stirred for 6 h. The mixture was allowed to reach room temperature and was then poured into ice-cold water (150 mL) and extracted with MTBE (3 x 100 mL). The combined organic phases were washed with brine, dried over  $MgSO_4$ , filtered and the solvent was removed under reduced pressure. The crude product was purified by flash column chromatography (PE/EtOAc = 100% PE  $\rightarrow$  20:1) and residual allyl bromide was removed under high vacuum overnight to yield compound **230** (1.47 g, 4.57 mmol, 50% o3s) as a pale-yellow oil.

$R_f$  = 0.6 (PE/EtOAc = 2:1);

$^1H$ -NMR (400 MHz,  $CDCl_3$ ,  $CHCl_3$  = 7.26 ppm):  $\delta$  6.56 (t,  $J$  = 1.8 Hz, 1H,  $H_{Ar}$ ), 6.49 (t,  $J$  = 1.9 Hz, 1H,  $H_{Ar}$ ), 6.28 (t,  $J$  = 2.2 Hz, 1H,  $H_{Ar}$ ), 5.86 – 5.77 (m, 2H, allyl), 5.19 (s, 2H, allyl), 5.17 – 5.16 (m, 1H, allyl), 5.15 – 5.14 (m, 1H, allyl), 5.10 (s, 2H, MOM), 3.88 – 3.87 (m, 4H, allyl), 3.26 (s, 3H, MOM) ppm;

$^{13}C$ -NMR (400 MHz,  $CDCl_3$ ,  $CDCl_3$  = 77.16 ppm):  $\delta$  159.0 (s, C-5), 150.7 (s, C-1), 133.2 (d, 2C, allyl), 123.5 (s, C-3), 116.5 (t, 2C, allyl), 109.6 (d,  $C_{Ar}$ ), 107.4 (d,  $C_{Ar}$ ), 99.7 (d,  $C_{Ar}$ ), 94.7 (t, MOM), 56.2 (q, MOM), 52.9 (t, 2C, allyl) ppm;

HRMS-ESI  $m/z$  for  $C_{14}H_{19}BrNO_2$   $[M+H]^+$  calc. 312.0599, found 312.0596.

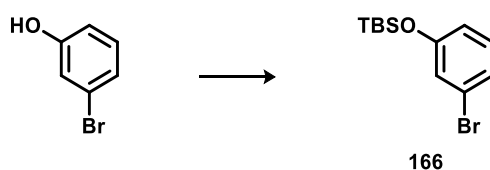
**(3-Bromophenoxy)(*tert*-butyl)dimethylsilane (166)**

3-Bromophenol (540 mg, 3.12 mmol, 1.0 eq.) was dissolved in  $CH_2Cl_2$  at room temperature and TBSCl (533 mg, 3.43 mmol, 1.1 eq.) followed by imidazole (234 mg, 3.43 mmol, 1.1 eq.) was added. Stirring was continued for 2 h at this temperature. The reaction was terminated by the addition of a water. The phases were separated and the aqueous phase was extracted with  $CH_2Cl_2$  (3 x 15 mL). The combined organic phases were dried over  $MgSO_4$ , filtered and the solvent was removed under reduced pressure. The crude product was purified by flash column chromatography (PE/EtOAc = 8:1) to yield silyl ether **166** (694 mg, 2.42 mmol, 77%) as a colorless oil.

$R_f$  = 0.7 (PE/EtOAc = 4:1);



**<sup>1</sup>H-NMR** (400 MHz, CDCl<sub>3</sub>, CHCl<sub>3</sub> = 7.26 ppm):  $\delta$  7.09 – 7.08 (m, 2H, H<sub>Ar</sub>), 7.01 – 7.00 (m, 1H, H<sub>Ar</sub>), 6.78 – 6.75 (m, 1H, H<sub>Ar</sub>), 0.98 (s, 9H, TBS), 0.20 (s, 6H, TBS) ppm;  
**HRMS-ESI**  $m/z$  for C<sub>12</sub>H<sub>19</sub>BrOSiNa [M+Na]<sup>+</sup> calc. 309.0287, found 309.0283.

***tert*-Butyldimethyl(3-(4,4,5,5-tetramethyl-1,3,2-dioxaborolan-2-yl)phenoxy)silane (164)**

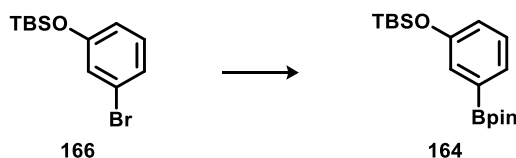

Following the procedure published by Erra Sola *et al.*<sup>[212]</sup> aryl bromide **166** (89 mg, 0.308 mmol, 1.0 eq.), B<sub>2</sub>pin<sub>2</sub> (117 mg, 0.462 mmol, 1.5 eq.), KOAc (91 mg, 0.924 mmol, 3.0 eq.) and Pd(dppf)Cl<sub>2</sub>·CH<sub>2</sub>Cl<sub>2</sub> (26 mg, 0.031 mmol, 0.1 eq.) were placed in a microwave vial, the vial was sealed and the atmosphere was changed by 3 vacuum-argon cycles. 1,4-Dioxan (degassed in ultrasonic bath for 20 min,  $c(\text{aryl bromide}) = 0.2$  mmol/mL) was added and the mixture was stirred for 20 min at 120 °C under microwave irradiation. The reaction mixture was filtered through a plug of Celite<sup>®</sup> and the filtrate was partitioned between MTBE and water. The phases were separated and the aqueous phase was extracted with MTBE (3x). The combined organic phases were washed with brine, dried over MgSO<sub>4</sub>, filtered and the solvent was removed under reduced pressure. The crude product was purified by flash column chromatography (PE/EtOAc = 8:1) to yield pinacol boronic ester **164** (84 mg, 0.250 mmol, 81%) as a colorless oil that solidified upon storage overnight in the refrigerator to give a colorless solid.

The analytical data are consistent with those reported in the literature.<sup>[213]</sup>

$R_f = 0.6$  (PE/EtOAc = 4:1);

**<sup>1</sup>H-NMR** (400 MHz, CDCl<sub>3</sub>, CHCl<sub>3</sub> = 7.26 ppm):  $\delta$  7.39 (d,  $J = 7.2$  Hz, 1H, H<sub>Ar</sub>), 7.27 (s, 1H, H-2), 7.23 (t,  $J = 7.7$  Hz, H-5), 6.94 – 6.91 (m, 1H, H<sub>Ar</sub>), 1.34 (s, 12H, Bpin), 0.99 (s, 9H, TBS), 0.19 (s, 6H, TBS) ppm;

**m.p.** 35–38 °C (lit. 37–38 °C)<sup>[213]</sup>;

**HRMS-ESI**  $m/z$  for C<sub>18</sub>H<sub>32</sub>BO<sub>3</sub>Si [M+H]<sup>+</sup> calc. 335.2208, found 335.2209.

## 5.5 Reformatsky Approach

**(4*S*)-7-((*tert*-Butyldimethylsilyl)oxy)-4-methoxyheptan-3-ol (358)**

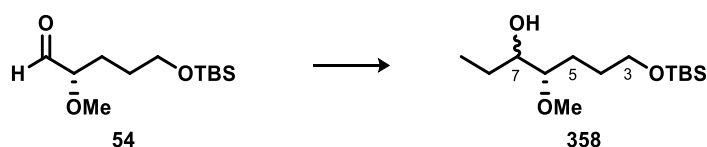

Aldehyde **54** (164 mg, 0.666 mmol, 1.0 eq.) was dissolved in THF (7 mL) and cooled to –78 °C and EtMgBr (3.0 M in Et<sub>2</sub>O, 444  $\mu$ L, 1.33 mmol, 2.0 eq.) was added dropwise. Stirring was continued at this temperature for 30 min before the reaction was warmed to 0 °C and stirred for 1 h. The reaction was terminated by the addition of a saturated aqueous NH<sub>4</sub>Cl

solution (10 mL). The phases were separated and the aqueous phase was extracted with MTBE (3 x 10 mL). The combined organic phases were dried over MgSO<sub>4</sub>, filtered and the solvent was removed under reduced pressure. The crude product was purified by flash column chromatography (PE/EtOAc = 10:1) to yield alcohol **358** (149 mg, 0.540 mmol, 81%, d.r. = 5:1) as a colorless oil.

$R_f$  = 0.3 (PE/EtOAc = 4:1);

<sup>1</sup>H-NMR (400 MHz, CDCl<sub>3</sub>, CHCl<sub>3</sub> = 7.26 ppm):  $\delta$  3.61 (t,  $J$  = 6.0 Hz, 2H, H-3), 3.44 – 3.41 (m 1H, H-7), 3.41 (s, 3H, OMe), 3.07 – 3.03 (m, 1H, H-6), 2.16 (bs, 1H, OH), 1.70 – 1.37 (m, 6H, H-4, H-5, H-8), 0.98 (t,  $J$  = 7.4 Hz, 3H, Me-8), 0.89 (s, 9H, TBS), 0.04 (s, 6H, TBS) ppm;  
<sup>13</sup>C-NMR (400 MHz, CDCl<sub>3</sub>, CDCl<sub>3</sub> = 77.16 ppm):  $\delta$  83.8 (d, C-6), 74.1 (d, C-7), 63.3 (t, C-3), 58.1 (q, OMe), 28.2 (t, C-8), 26.3 (t, C-4), 26.1 (t, C-5), 26.1 (q, 3C, TBS), 18.5 (s, TBS), 10.2 (q, Me-8), -5.2 (q, 2C, TBS) ppm;

$[\alpha]_D^{26}$  = +5.7 ( $c$  = 1.0, CHCl<sub>3</sub>);

HRMS-ESI  $m/z$  for C<sub>14</sub>H<sub>32</sub>O<sub>3</sub>SiNa [M+Na]<sup>+</sup> calc. 299.2018, found 299.2019.

**(S)-7-((tert-Butyldimethylsilyl)oxy)-4-methoxyheptan-3-one (255)**

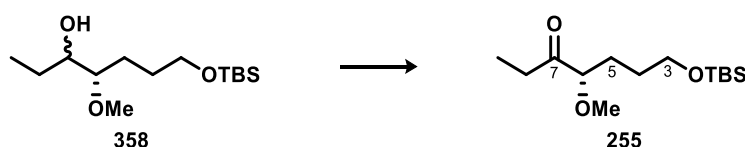

The alcohol **358** (131 mg, 0.474 mmol, 1.0 eq.) was dissolved in CH<sub>2</sub>Cl<sub>2</sub> (5 mL) and cooled to 0 °C. NaHCO<sub>3</sub> (200 mg, 2.37 mmol, 5.0 eq.) was added followed by DMP (362 mg, 0.853 mmol, 1.8 eq.). The mixture was stirred at this temperature for 15 min before it was allowed to reach room temperature and stirring was continued for 1.5 h. The reaction was diluted with CH<sub>2</sub>Cl<sub>2</sub> and terminated by the addition of Na<sub>2</sub>S<sub>2</sub>O<sub>3</sub> (10 w%) in a saturated aqueous NaHCO<sub>3</sub> solution. Stirring was continued until a clear organic phase was obtained. The phases were separated and the aqueous phase was extracted with CH<sub>2</sub>Cl<sub>2</sub> (3 x 20 mL). The combined organic phases were dried over MgSO<sub>4</sub>, filtered and the solvent was removed under reduced pressure. The crude product was purified by flash column chromatography (PE/EtOAc = 10:1) to yield ketone **255** (109 mg, 0.398 mmol, 84%) as a colorless oil.

$R_f$  = 0.6 (PE/EtOAc = 4:1);

<sup>1</sup>H-NMR (400 MHz, CDCl<sub>3</sub>, CHCl<sub>3</sub> = 7.26 ppm):  $\delta$  3.64 – 3.55 (m, 3H, H-3, H-6), 3.33 (s, 3H, OMe), 2.59 – 2.44 (m, 2H, H-8), 1.63 – 1.48 (m, 4H, H-4, H-5), 1.05 (t,  $J$  = 7.3 Hz, 3H, Me-8), 0.87 (s, 9H, TBS), 0.03 (s, 6H, TBS) ppm;

<sup>13</sup>C-NMR (400 MHz, CDCl<sub>3</sub>, CDCl<sub>3</sub> = 77.16 ppm):  $\delta$  213.7 (s, C-7), 87.0 (d, C-6), 62.7 (t, C-3), 58.2 (q, OMe), 30.9 (t, C-8), 28.6 (t, C-4), 28.4 (t, C-5), 26.1 (q, 3C, TBS), 18.4 (s, TBS), 7.4 (q, Me-8), -5.2 (q, 2C, TBS) ppm;

$[\alpha]_D^{20}$  = -34.5 ( $c$  = 1.0, CHCl<sub>3</sub>);

HRMS-ESI  $m/z$  for C<sub>14</sub>H<sub>30</sub>O<sub>3</sub>SiNa [M+Na]<sup>+</sup> calc. 297.1862, found 297.1866.

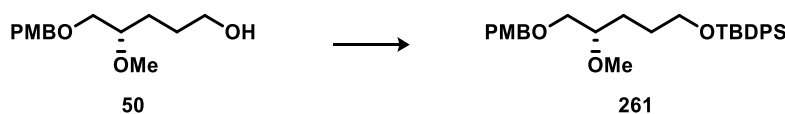
**(S)-tert-Butyl((4-methoxy-5-((4-methoxybenzyl)oxy)pentyl)oxy)diphenylsilane (261)**

Alcohol **50** (317 mg, 1.25 mmol, 1.0 eq.) was dissolved in CH<sub>2</sub>Cl<sub>2</sub> (5 mL) in a microwave vial. DMAP (15 mg, 0.125 mmol, 0.1 eq.) and imidazole (102 mg, 1.50 mmol, 1.2 eq.) were added followed by TBDPSCI (389  $\mu$ L, 1.50 mmol, 1.2 eq.). The mixture was heated to 35 °C and stirring was continued for 3 h. The reaction was terminated by the addition of a saturated aqueous NH<sub>4</sub>Cl solution (15 mL) and diluted with CH<sub>2</sub>Cl<sub>2</sub> (20 mL). The phases were separated and the aqueous phase was extracted with CH<sub>2</sub>Cl<sub>2</sub> (3 x 15 mL). The combined organic phases were dried over MgSO<sub>4</sub>, filtered and the solvent was removed under reduced pressure. The crude product was purified by flash column chromatography (PE/EtOAc = 10:1) to yield silyl ether **261** (584 mg, 1.19 mmol, 95%) as a colorless oil which was used in the next step without further analysis.

$R_f$  = 0.4 (PE/EtOAc = 4:1);

HRMS-ESI  $m/z$  for C<sub>30</sub>H<sub>40</sub>O<sub>4</sub>SiNa [M+Na]<sup>+</sup> calc. 515.2594, found 515.2599.

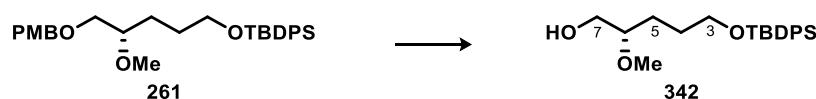
**(S)-5-((tert-Butyldiphenylsilyl)oxy)-2-methoxypentan-1-ol (342)**

PMB ether **261** (583 mg, 1.19 mmol, 1.0 eq.) was dissolved in CH<sub>2</sub>Cl<sub>2</sub>/pH7 phosphate buffer (9:1, 12.5 mL) and was cooled to 0 °C. DDQ (403 mg, 1.78 mmol, 1.5 eq.) was added and the mixture was allowed to reach room temperature. Stirring was continued for 1.5 h. The reaction was terminated by the addition of a saturated aqueous Na<sub>2</sub>S<sub>2</sub>O<sub>3</sub> solution (20 mL) and a saturated aqueous NaHCO<sub>3</sub> solution (20 mL). The resulting emulsion was broken up by addition of aqueous NaOH (10%, 2 mL). The phases were separated and the aqueous phase was extracted with CH<sub>2</sub>Cl<sub>2</sub> (4 x 70 mL). The combined organic phases were washed with brine, dried over MgSO<sub>4</sub>, filtered and the solvent was removed under reduced pressure. The crude product was purified by flash column chromatography (PE/MTBE = 4:1 → 100% MTBE) to yield alcohol **342** (336 mg, 0.902 mmol, 76%) as a colorless oil.

$R_f$  = 0.1 (PE/EtOAc = 4:1);

<sup>1</sup>H-NMR (500 MHz, CDCl<sub>3</sub>, CHCl<sub>3</sub> = 7.26 ppm):  $\delta$  7.67 – 7.66 (m, 4H, TBDPS), 7.43 – 7.36 (m, 6H, TBDPS), 3.68 (t,  $J$  = 5.9 Hz, 2H, H-3), 3.66 (dd,  $J$  = 11.5, 3.4 Hz, 1H, H-7), 3.47 (dd,  $J$  = 11.5, 6.5 Hz, 1H, H-7'), 3.38 (s, 3H, OMe), 3.28 – 3.26 (m, 1H, H-6), 1.87 (bs, 1H, OH), 1.67 – 1.52 (m, 4H, H-4, H-5), 1.05 (s, 9H, TBDPS) ppm;

<sup>13</sup>C-NMR (500 MHz, CDCl<sub>3</sub>, CDCl<sub>3</sub> = 77.16 ppm):  $\delta$  135.7 (d, 4C, TBDPS), 134.1 (s, 2C, TBDPS), 129.7 (d, 2C, TBDPS), 127.8 (d, 4C, TBDPS), 81.4 (d, C-6), 64.1 (t, C-7), 63.9 (t, C-3), 57.1 (q, OMe), 28.3 (t, C-4), 27.0 (t, C-5), 26.6 (q, 3C, TBDPS), 19.3 (s, TBDPS) ppm;

$[\alpha]_D^{20}$  = +11.5 ( $c$  = 1.0, CHCl<sub>3</sub>);

HRMS-ESI  $m/z$  for C<sub>22</sub>H<sub>32</sub>O<sub>3</sub>SiNa [M+Na]<sup>+</sup> calc. 395.2019, found 395.2023.

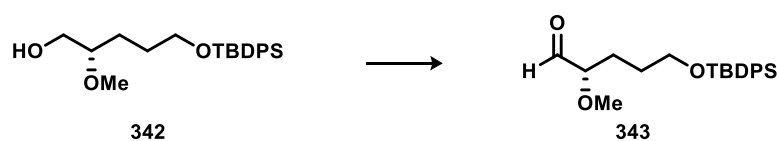
**(S)-5-((*tert*-Butyldiphenylsilyl)oxy)-2-methoxypentanal (343)**

Alcohol **342** (316 mg, 0.848 mmol, 1.0 eq.) was dissolved in CH<sub>2</sub>Cl<sub>2</sub> (6 mL) and cooled to 0 °C. NaHCO<sub>3</sub> (356 mg, 4.24 mmol, 5.0 eq.) was added followed by DMP (647 mg, 1.53 mmol, 1.8 eq.). The mixture was stirred at this temperature for 30 min before the mixture was allowed to reach room temperature and stirring was continued for 1.5 h. The reaction was diluted with CH<sub>2</sub>Cl<sub>2</sub> and terminated by the addition of Na<sub>2</sub>S<sub>2</sub>O<sub>3</sub> (10 w%) in a saturated aqueous NaHCO<sub>3</sub> solution. Stirring was continued until a clear organic phase was obtained. The phases were separated and the aqueous phase was extracted with CH<sub>2</sub>Cl<sub>2</sub> (3 x 20 mL). The combined organic phases were dried over MgSO<sub>4</sub>, filtered and the solvent was removed under reduced pressure. The crude product was purified by flash column chromatography (PE/EtOAc = 10:1) to yield aldehyde **343** (297 mg, 0.802 mmol, 95%) as a colorless oil which was used in the next step without further analysis.

$R_f = 0.5$  (PE/EtOAc = 1:1).

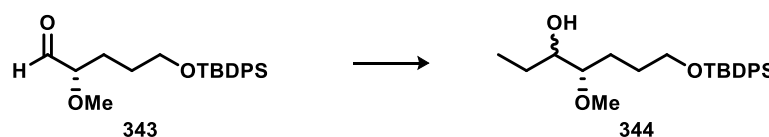
**(4S)-7-((*tert*-Butyldiphenylsilyl)oxy)-4-methoxyheptan-3-ol (344)**

Aldehyde **343** (297 mg, 0.802 mmol, 1.0 eq.) was dissolved in THF (8 mL) and cooled to –78 °C and EtMgBr (3.0 M in Et<sub>2</sub>O, 668 μL, 2.0 mmol, 2.5 eq.) was added dropwise. Stirring was continued at this temperature for 30 min before the reaction was warmed to 0 °C and stirred for 1 h. The reaction was terminated by the addition of a saturated aqueous NH<sub>4</sub>Cl solution. The phases were separated and the aqueous phase was extracted with MTBE (3 x 15 mL). The combined organic phases were dried over MgSO<sub>4</sub>, filtered and the solvent was removed under reduced pressure. The crude alcohol **344** was obtained as a colorless oil which was used in the next step without further purification.

$R_f = 0.2$  (PE/EtOAc = 4:1);

$[\alpha]_D^{26} = +6.1$  ( $c = 1.0$ , CHCl<sub>3</sub>);

**HRMS-ESI**  $m/z$  for C<sub>24</sub>H<sub>36</sub>O<sub>3</sub>SiNa [M+Na]<sup>+</sup> calc. 423.2332, found 423.2331.

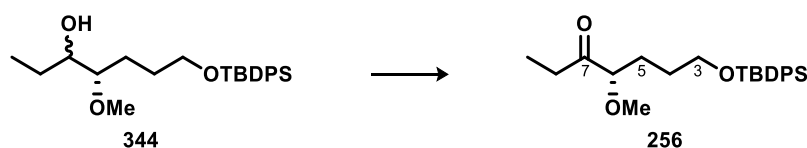
**(S)-7-((*tert*-Butyldiphenylsilyl)oxy)-4-methoxyheptan-3-one (256)**

Alcohol **344** (296 mg, 0.739 mmol, 1.0 eq.) was dissolved in CH<sub>2</sub>Cl<sub>2</sub> (8 mL) and cooled to 0 °C. NaHCO<sub>3</sub> (310 mg, 3.69 mmol, 5.0 eq.) was added followed by DMP (564 mg, 1.33 mmol, 1.8 eq.). The mixture was stirred at this temperature for 15 min before the mixture was allowed to reach room temperature and stirring was continued for 1.5 h. The reaction was diluted with CH<sub>2</sub>Cl<sub>2</sub> and terminated by the addition of Na<sub>2</sub>S<sub>2</sub>O<sub>3</sub> (10 w%) in a saturated aqueous NaHCO<sub>3</sub> solution. Stirring was continued until a clear organic phase was obtained. The phases were separated and the aqueous phase was extracted with CH<sub>2</sub>Cl<sub>2</sub> (3 x 25 mL). The combined organic phases were dried over MgSO<sub>4</sub>, filtered and the solvent was removed under reduced pressure. The crude product was purified by flash column chromatography (PE/EtOAc = 10:1) to yield ketone **256** (231 mg, 0.579 mmol, 72% o2s) as a colorless oil.

$R_f$  = 0.6 (PE/EtOAc = 4:1);

<sup>1</sup>H-NMR (400 MHz, CDCl<sub>3</sub>, CHCl<sub>3</sub> = 7.26 ppm): δ 7.67 – 7.64 (m, 4H, TBDPS), 7.44 – 7.35 (m, 6H, TBDPS), 3.69 – 3.64 (m, 2H, H-3), 3.61 (dd, *J* = 7.4, 5.1 Hz, 1H, H-6), 3.32 (s, 3H, OMe), 2.59 – 2.43 (m, 2H, H-8), 1.70 – 1.54 (m, 4H, H-4, H-5), 1.06 – 1.04 (m, 12H, Me-8, TBDPS) ppm;

<sup>13</sup>C-NMR (400 MHz, CDCl<sub>3</sub>, CDCl<sub>3</sub> = 77.16 ppm): δ 213.6 (s, C-7), 135.7 (d, 4C, TBDPS), 134.0 (s, TBDPS), 134.0 (s, TBDPS), 129.7 (d, 2C, TBDPS), 127.8 (d, 4C, TBDPS), 87.0 (s, C-6), 63.5 (t, C-3), 58.2 (q, OMe), 30.9 (t, C-8), 28.5 (t, C-4), 28.2 (t, C-5), 27.0 (q, 3C, TBDPS), 19.3 (s, TBDPS), 7.4 (q, Me-8) ppm;

$[\alpha]_D^{20}$  = –39.0 (*c* = 1.0, CHCl<sub>3</sub>);

HRMS-ESI C<sub>24</sub>H<sub>34</sub>O<sub>3</sub>SiNa [M+Na]<sup>+</sup> calc. 421.2175, found 421.2179.

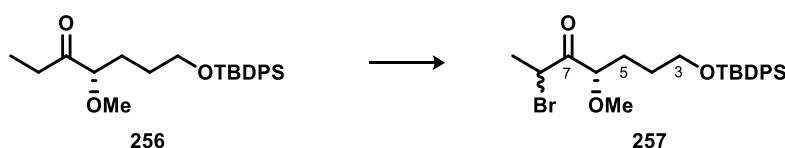
**(4S)-2-Bromo-7-((*tert*-butyldiphenylsilyl)oxy)-4-methoxyheptan-3-one (257)**

Ketone **256** (3.6 mg, 9.10 μmol, 1.0 eq.) was dissolved in THF (0.5 mL) and cooled to 0 °C. PTAB (4.1 mg, 10.90 μmol, 1.2 eq.) was added as a solution in 0.1 mL THF. The mixture was warmed to room temperature and stirring was continued for 2.5 h. The reaction was terminated by the addition of a saturated aqueous NH<sub>4</sub>Cl solution. The phases were separated and the aqueous layer was extracted with MTBE (3 x 2 mL). The combined organic layers were dried over MgSO<sub>4</sub>, filtered and the solvent was removed under reduced pressure. Crude α-bromoketone **257** (4.0 mg) was obtained as a yellow-brown oil. Since the product is unstable, it was immediately used in the SmI<sub>2</sub>-mediated Reformatsky reaction without further purification.

$R_f = 0.4$  (PE/EtOAc = 10:1);

$^1\text{H-NMR}$  (500 MHz,  $\text{CDCl}_3$ ,  $\text{CHCl}_3 = 7.26$  ppm):  $\delta$  7.66 – 7.64 (m, 4H, TBDPS), 7.43 – 7.36 (m, 6H, TBDPS), 4.63 (q,  $J = 6.7$  Hz, 1H, H-8), 4.63 (dd,  $J = 7.8, 4.5$  Hz, 1H, H-6), 3.71 – 3.68 (m, 2H, H-3), 3.34 (s, 3H, OMe), 1.90 – 1.84 (m, 2H, H-5), 1.73 (d,  $J = 6.8$  Hz, 3H, Me-8), 1.71 – 1.64 (m, 2H, H-4), 1.05 (s, 9H, TBDPS) ppm;

**HRMS-ESI**  $m/z$  for  $\text{C}_{24}\text{H}_{33}\text{BrO}_3\text{SiNa}$   $[\text{M}+\text{Na}]^+$  calc. 499.1280, found 499.1281.

**(3S,4R,5S,7S)-8-(benzyloxy)-5-methoxy-3,7-dimethyloct-1-en-4-ol (252)**

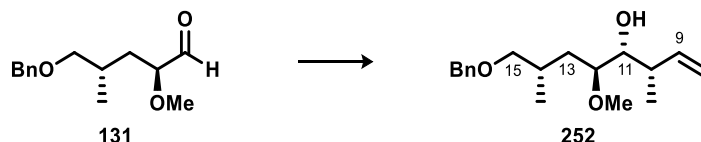

(*Z*)-Crotylboronate (**74**, 425 mg, 1.43 mmol, 2.5 eq.) was dissolved in PhMe (3 mL) and molecular sieves (4 Å, powder, 200 mg) were added. The mixture was stirred for 20 min at room temperature and then cooled to  $-78$  °C. Aldehyde **131** (135 mg, 0.571 mmol) as a solution in PhMe (2 mL) was added slowly to the reaction. Stirring was continued at  $-78$  °C for 18 h. The reaction was terminated by the addition of an aqueous 1 M NaOH solution. The mixture was warmed to room temperature and stirred for 1 h before it was filtered through Celite® and rinsed with MTBE. The phases were separated and the aqueous phase was extracted with MTBE (3 x 15 mL). The combined organic phases were dried over  $\text{MgSO}_4$ , filtered and the solvent was removed under reduced pressure. The crude product was purified by flash column chromatography (PE/EtOAc = 10:1  $\rightarrow$  4:1) to yield alkene **252** (114 mg, 0.390 mmol, 68%, *d.r.* = 17:1) as a colorless oil.

$R_f = 0.4$  (PE/EtOAc = 4:1);

$^1\text{H-NMR}$  (400 MHz,  $\text{CDCl}_3$ ,  $\text{CHCl}_3 = 7.26$  ppm):  $\delta$  7.34 – 7.26 (5H, Bn), 5.65 (ddd,  $J = 17.2, 10.3, 8.5$  Hz, 1H, H-9), 5.08 – 5.00 (m, 2H, H-8), 4.51 (s, 2H, Bn), 3.62 (dd,  $J = 8.7, 3.5$  Hz), 3.35 (s, 3H, OMe), 3.35 – 3.24 (m, 3H, H-12, H-15), 2.30 – 2.24 (m, 1H, H-10), 2.09 – 1.97 (m, 1H, H-14), 1.69 (ddd,  $J = 14.1, 10.3, 3.6$  Hz, 1H, H-13), 1.23 (ddd,  $J = 14.3, 9.9, 2.5$  Hz, 1H, H-13'), 1.13 (d,  $J = 6.6$  Hz, 3H, Me-10), 0.92 (d,  $J = 6.7$  Hz, 3H, Me-14) ppm;

$^{13}\text{C-NMR}$  (400 MHz,  $\text{CDCl}_3$ ,  $\text{CDCl}_3 = 77.16$  ppm):  $\delta$  140.3 (d, C-9), 138.8 (s, Bn), 128.4 (d, 2C, Bn), 127.7 (d, 2C, Bn), 127.6 (d, Bn), 115.3 (t, C-8), 80.2 (d, C-12), 76.6 (t, C-15), 73.5 (d, C-11), 73.1 (t, Bn), 57.2 (q, OMe), 40.5 (d, C-10), 31.5 (t, C-13), 29.8 (d, C-14), 17.3 (q, Me-10), 17.0 (q, Me-14) ppm;

$[\alpha]_D^{20} = -11.6$  ( $c = 1.0$ ,  $\text{CHCl}_3$ );

**HRMS-ESI**  $m/z$  for  $\text{C}_{18}\text{H}_{28}\text{O}_3\text{Na}$   $[\text{M}+\text{Na}]^+$  calc. 315.1936, found 315.1937.

**(((3*S*,4*R*,5*S*,7*S*)-8-(Benzyloxy)-5-methoxy-3,7-dimethyloct-1-en-4-yl)oxy)(*tert*-butyl)dimethylsilane (345)**

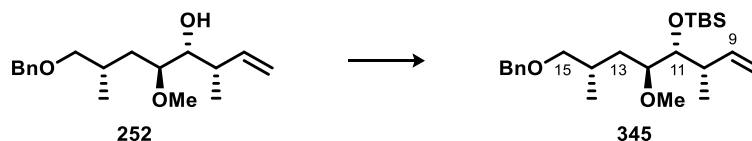

Alkene **252** (94 mg, 0.322 mmol, 1.0 eq.) was dissolved in CH<sub>2</sub>Cl<sub>2</sub> (3 mL) and cooled to 0 °C. 2,6-Lutidine (112 μL, 0.964 mmol, 3.0 eq.) was added, followed by dropwise addition of TBSOTf (148 μL, 0.643 mmol, 2.0 eq.). Stirring was continued at 0 °C for 20 minutes and 15 minutes at room temperature. The reaction was terminated by the addition of a saturated aqueous NH<sub>4</sub>Cl solution. The phases were separated and the aqueous phase was extracted with CH<sub>2</sub>Cl<sub>2</sub> (3 x 5 mL). The combined organic phases were washed with brine, dried over MgSO<sub>4</sub>, filtered and the solvent was removed under reduced pressure. The crude product was purified by flash column chromatography (PE/EtOAc = 10:1 → 6:1) to yield homoallylic silyl ether **345** (97 mg, 0.239 mmol, 74%) as a colorless oil.

$R_f = 0.7$  (PE/EtOAc = 4:1);

**<sup>1</sup>H-NMR** (400 MHz, CDCl<sub>3</sub>, CHCl<sub>3</sub> = 7.26 ppm): δ 7.31 – 7.24 (5H, Bn), 5.69 (ddd,  $J = 17.2, 10.3, 8.5$  Hz, 1H, H-9), 5.02 – 4.96 (m, 2H, H-8), 4.51 (s, 2H, Bn), 3.59 (dd,  $J = 8.1, 1.8$  Hz, 1H, H-11), 3.38 – 3.32 (m, 1H, H-12), 3.29 (s, 3H, OMe), 3.27 – 3.21 (m, 2H, H-15), 2.28 – 2.19 (m, 1H, H-10), 2.05 – 1.94 (m, 1H, H-14), 1.68 – 1.60 (m, 1H, H-13), 1.15 (ddd,  $J = 14.4, 10.1, 2.0$  Hz, 1H, H-13'), 1.06 (d,  $J = 6.7$  Hz, 3H, Me-10), 0.92 (d,  $J = 6.7$  Hz, 3H, Me-14) ppm;

**<sup>13</sup>C-NMR** (400 MHz, CDCl<sub>3</sub>, CDCl<sub>3</sub> = 77.16 ppm): δ 141.8 (d, C-9), 139.1 (s, Bn), 128.4 (d, 2C, Bn), 127.6 (d, 2C, Bn), 127.4 (d, Bn), 114.5 (t, C-8), 81.3 (d, C-12), 76.8 (t, C-15), 76.1 (d, C-11), 72.9 (t, Bn), 57.4 (q, OMe), 42.1 (d, C-10), 33.2 (t, C-13), 30.3 (d, C-14), 26.3 (q, 3C, TBS), 18.6 (s, TBS), 17.8 (q, Me-10), 17.1 (q, Me-14), – 3.7 (q, TBS), – 4.6 (q, TBS) ppm;

$[\alpha]_D^{23} = -6.8$  ( $c = 1.0$ , CHCl<sub>3</sub>);

**HRMS-ESI**  $m/z$  for C<sub>24</sub>H<sub>42</sub>O<sub>3</sub>SiNa [M+Na]<sup>+</sup> calc. 429.2801, found 429.2805.

**(3*S*,4*R*,5*S*,7*S*)-8-(Benzyloxy)-4-((*tert*-butyldimethylsilyl)oxy)-5-methoxy-3,7-dimethyloctane-1,2-diol (253)**

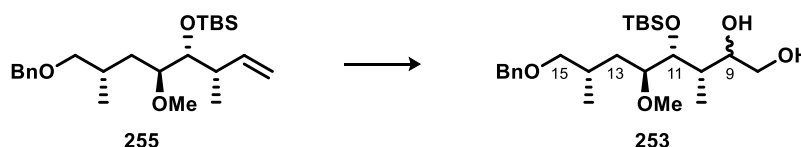

Alkene **255** (83 mg, 0.204 mmol, 1.0 eq.) was dissolved in CH<sub>2</sub>Cl<sub>2</sub> (2 mL) and NMO (80 mg, 0.572 mmol, 2.8 mmol) was added followed by OsO<sub>4</sub> (4% in H<sub>2</sub>O, 63 μL, 0.010 mmol, 0.05 eq.). Stirring was continued at room temperature for 18 h. The reaction was terminated by the addition of a saturated aqueous Na<sub>2</sub>S<sub>2</sub>O<sub>3</sub> solution. The phases were separated and the aqueous phase was extracted with MTBE (3 x 10 mL). The combined organic phases were

dried over  $\text{MgSO}_4$ , filtered and the solvent was removed under reduced pressure. The crude product was purified by flash column chromatography (PE/EtOAc = 2:1) to yield diastereomeric diol **253** (71 mg, 0.161 mmol, 79%) as pale orange-brown oil.

$R_f$  = 0.4 (PE/EtOAc = 1:2);

$^1\text{H-NMR}$  (600 MHz,  $\text{CDCl}_3$ ,  $\text{CHCl}_3$  = 7.26 ppm):  $\delta$  7.31 – 7.26 (5H, Bn), 4.51 (s, 2H, Bn), 3.97 – 3.39 (m, 1H, H-11), 3.74 – 3.70 (m, 1H, H-8), 3.61 – 3.58 (m, 1H, H-9), 3.49 – 3.45 (m, 1H, H-8'), 3.43 – 3.37 (m, 1H, H-12), 3.36 (s, 3H, OMe), 3.31 – 3.24 (m, 2H, H-15), 2.37 (bs, 2H, OH), 2.05 – 1.99 (m, 1H, H-10), 1.98 – 1.90 (m, 1H, H-14), 1.75 – 1.67 (m, 1H, H-13), 1.31 – 1.25 (m, 1H, H-13'), 0.98 (d,  $J$  = 7.1 Hz, 3H, Me-10), 0.92 (d,  $J$  = 6.1 Hz, 3H, Me-14), 0.91 (s, 9H, TBS), 0.11 (bs, 6H, TBS) ppm;

$^{13}\text{C-NMR}$  (600 MHz,  $\text{CDCl}_3$ ,  $\text{CDCl}_3$  = 77.16 ppm):  $\delta$  138.9 (s, Bn), 128.4 (d, 2C, Bn), 127.7 (d, 2C, Bn), 127.5 (d, Bn), 80.9 (d, C-12), 76.9 (d, C-11, under solvent peak), 76.5 (t, C-15), 74.0 (d, C-9), 73.0 (t, Bn), 65.2 (t, C-8), 58.1 (q, OMe), 38.7 (d, C-14), 35.8 (t, C-13), 30.5 (d, C-10), 26.1 (q, 3C, TBS), 18.3 (s, TBS), 17.1 (q, Me-14), 13.0 (q, Me-10), – 4.1 (q, TBS), – 4.8 (q, TBS) ppm;

**HRMS-ESI**  $m/z$  for  $\text{C}_{24}\text{H}_{44}\text{O}_5\text{SiNa}$   $[\text{M}+\text{Na}]^+$  calc. 463.2856, found 463.2858.

**(2R,3R,4S,6S)-7-(Benzyloxy)-3-((tert-butyldimethylsilyl)oxy)-4-methoxy-2,6-dimethylheptanal (254)**

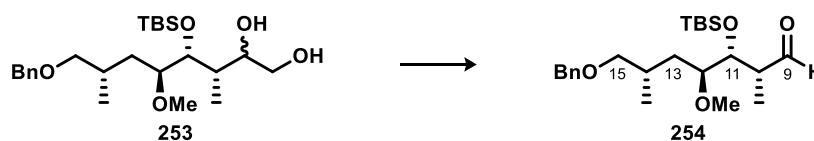

Diol **253** (71 mg, 0.161 mmol, 1.0 eq.) was dissolved in acetone (4 mL) and a solution of  $\text{NaIO}_4$  (97 mg, 0.452 mmol, 2.8 eq.) in water (1 mL) was added. Stirring was continued at room temperature for 3 h. The mixture was filtered through a plug of Celite<sup>®</sup>, the plug was rinsed with  $\text{CH}_2\text{Cl}_2$  (5 mL) and the organic phase washed with water (10 mL). The aqueous phase was extracted with  $\text{CH}_2\text{Cl}_2$  (3 x 10 mL) and the combined organic phases were dried over  $\text{MgSO}_4$ , filtered and the solvent was removed under reduced pressure. The crude product was purified by flash column chromatography (PE/EtOAc = 10:1) to yield aldehyde **254** (40 mg, 0.098 mmol, 61%, 73% brsm) as a colorless oil.

$R_f$  = 0.8 (PE/EtOAc = 1:2);

$^1\text{H-NMR}$  (400 MHz,  $\text{CDCl}_3$ ,  $\text{CHCl}_3$  = 7.26 ppm):  $\delta$  9.71 (s, 1H, H-9), 7.33 – 7.26 (5H, Bn), 4.50 (s, 2H, Bn), 4.11 (m, 1H, H-11), 3.40 (s, 3H, OMe), 3.56 – 3.32 (m, 1H, H-12), 3.29 – 3.25 (m, 2H, H-15), 2.62 – 2.55 (m, 1H, H-10), 2.04 – 1.96 (m, 1H, H-14), 1.60 (ddd,  $J$  = 14.0, 10.3, 3.6 Hz, 1H, H-13), 1.28 – 1.20 (m, 1H, H-13'), 1.18 (d,  $J$  = 7.1 Hz, 3H, Me-10), 0.96 (d,  $J$  = 6.6 Hz, 3H, Me-14), 0.88 (s, 9H, TBS), 0.09 (s, 3H, TBS), 0.02 (s, 3H, TBS) ppm;

$^{13}\text{C-NMR}$  (400 MHz,  $\text{CDCl}_3$ ,  $\text{CDCl}_3$  = 77.16 ppm):  $\delta$  204.5 (d, C-9), 138.9 (s, Bn), 128.4 (d, 2C, Bn), 127.7 (d, 2C, Bn), 127.5 (d, Bn), 81.9 (d, C-12), 76.4 (t, C-15), 73.6 (d, C-11), 73.1 (t, Bn), 58.8 (q, OMe), 49.8 (d, C-10), 35.6 (t, C-13), 30.4 (d, C-14), 26.1 (q, 3C, TBS), 18.3 ((s, TBS), 16.9 (q, Me-14), 9.6 (q, Me-10), – 3.9 (q, TBS), – 4.5 (q, TBS) ppm;

$[\alpha]_D^{22} = -12.3$  ( $c$  = 3.0,  $\text{CHCl}_3$ );



**HRMS-ESI**  $m/z$  for  $C_{23}H_{40}O_4SiNa$   $[M+Na]^+$  calc. 431.2594, found 431.2591.

**(5*R*,6*S*,10*S*)-5-((1*S*,3*S*)-4-(Benzyloxy)-1-methoxy-3-methylbutyl)-7-hydroxy-10-methoxy-2,2,3,3,6,8,16,16-octamethyl-15,15-diphenyl-4,14-dioxo-3,15-disilaheptadecan-9-one (258)**

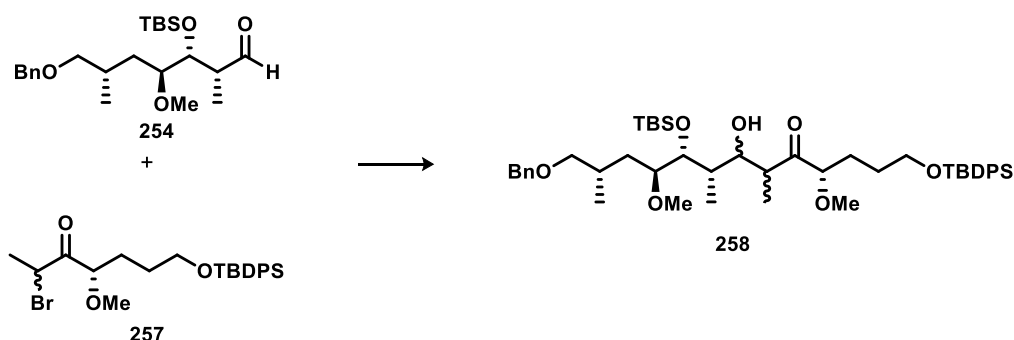

$\alpha$ -Bromoketone **257** (10 mg, 22.0  $\mu$ mol, 3.0 eq.) was dissolved in THF (180  $\mu$ l) and cooled to  $-78$   $^{\circ}$ C. A solution of the aldehyde **254** (3 mg, 7.3  $\mu$ mol, 1.0 eq.) in THF (360  $\mu$ L) was added. Afterwards,  $SmI_2$  (0.1 M in THF, 520  $\mu$ L, 51.4  $\mu$ mol, 7.0 eq.) was added dropwise and stirring was continued for 1 h. TLC and LCMS analysis indicated complete consumption of the aldehyde and the reaction was terminated by the addition of a saturated aqueous  $NH_4Cl$  solution. The phases were separated and the aqueous phase was extracted with  $Et_2O$  (3 x 5 mL). The combined organic phases were dried over  $MgSO_4$ , filtered and the solvent was removed under reduced pressure. The crude product was directly submitted to the dehydration reaction.

**HRMS-ESI**  $m/z$  for  $C_{47}H_{74}O_7Si_2Na$   $[M+Na]^+$  calc. 829.4871, found 829.4873.

**(5*R*,6*S*,10*S*,*E*)-5-((1*S*,3*S*)-4-(Benzyloxy)-1-methoxy-3-methylbutyl)-10-methoxy-2,2,3,3,6,8,16,16-octamethyl-15,15-diphenyl-4,14-dioxo-3,15-disilaheptadec-7-en-9-one (259)**

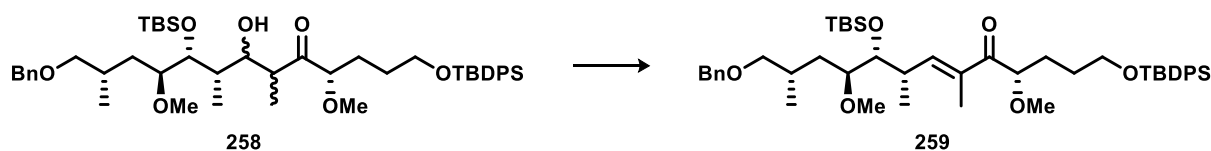

The crude diastereomeric mixture of  $\beta$ -hydroxy ketone **258** (7.3  $\mu$ mol, 1.0 eq.) was dissolved in dichloromethane (1.0 mL) and cooled to  $0$   $^{\circ}$ C before Martin's sulfurane (9.8 mg, 14.6  $\mu$ mol) was added and stirring was continued for 1 h. The reaction was terminated by the addition of a saturated aqueous  $NH_4Cl$  solution. The phases were separated and the aqueous phase was extracted with  $CH_2Cl_2$  (3 x 5 mL). The combined organic phases were dried over  $MgSO_4$ , filtered and the solvent was removed under reduced pressure. Enone **259** was detected in the crude mixture by HRMS analysis, but could not be recovered after purification by flash column chromatography (PE/ $EtOAc$  = 15:1  $\rightarrow$  2:1).

**HRMS-ESI**  $m/z$  for  $C_{47}H_{72}O_6Si_2Na$   $[M+Na]^+$  calc. 811.4765, found 811.4764.

## 5.6 Test Substrates for GdmF

### General Procedures

#### General Procedure for the Synthesis of SNAC Thioesters (GP1)

*N*-Acetylcysteamine (238 mg, 2.00 mmol, 1.0 eq.) and the respective carboxylic acid (2.00 mmol, 1.0 eq.) were dissolved in CH<sub>2</sub>Cl<sub>2</sub> (10 mL) and cooled to 0 °C. Then, DMAP (48.9 mg, 0.40 mmol, 0.2 eq.) and EDC·HCl (383 mg, 2.00 mmol, 1.0 eq.) were added subsequently. The mixture was allowed to reach room temperature and stirring was continued for 3 h. The reaction was then terminated by the addition of an aqueous 2 M HCl solution and the phases were separated. The aqueous phase was extracted with CH<sub>2</sub>Cl<sub>2</sub> (3 x 10 mL) and the combined organic phases were washed with a saturated aqueous NaHCO<sub>3</sub> solution and brine, dried over MgSO<sub>4</sub>, filtered and the solvent was removed under reduced pressure. The crude product was purified by flash column chromatography (PE/EtOAc = 1:1 → 100% EtOAc).

#### General Procedure for the Synthesis of Acyl Pantetheine Dimethyl Ketals (GP2)

Pantetheine dimethyl ketal (**273**, 155 mg, 0.49 mmol, 1.0 eq.) was dissolved in CH<sub>2</sub>Cl<sub>2</sub> (3 mL) and the respective carboxylic acid (0.49 mmol, 1.0 eq.) was added. The mixture was cooled to 0 °C and DMAP (48 mg, 0.39 mmol, 0.8 eq.) and EDC·HCl (187 mg, 0.98 mmol, 2.0 eq.) were added subsequently. The mixture was then allowed to reach room temperature and stirred for 2 h. The reaction was terminated by the addition of a 2 M HCl solution (8 mL), the phases were separated and the aqueous phase was extracted with CH<sub>2</sub>Cl<sub>2</sub> (3 x 3 mL). The combined organic phases were dried over MgSO<sub>4</sub>, filtered and the solvent was removed under reduced pressure. The crude product was purified by flash column chromatography (100% EtOAc).

#### General Procedure for the Acetonide Deprotection (GP3)<sup>[177]</sup>

The respective acetonide (1.0 eq.) was dissolved in MeCN (*c* = 0.1 mmol/mL), InCl<sub>3</sub> (2.0 eq.) was added, followed by water (4.0 eq.) and stirring was continued at room temperature for 16 h. Water and CH<sub>2</sub>Cl<sub>2</sub> were added and the phases were separated. The aqueous phase was extracted with CH<sub>2</sub>Cl<sub>2</sub> (6x). The combined organic phases were dried over MgSO<sub>4</sub>, filtered and the solvent was removed under reduced pressure. The crude product was purified by flash column chromatography (CH<sub>2</sub>Cl<sub>2</sub>/MeOH).

#### *S*-(2-Acetamidoethyl) (*E*)-but-2-enethioate (**267**)

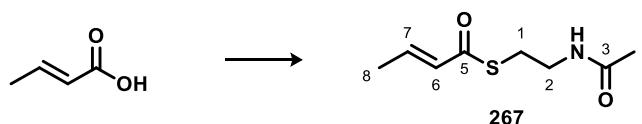

SNAC thioester **267** (285 mg, 1.52 mmol, 76%) was prepared following **GP1** using (*E*)-but-2-enoic acid and was obtained as a colorless solid.

The analytical data are consistent with those reported in the literature.<sup>[214,215]</sup>

**<sup>1</sup>H-NMR** (400 MHz, CDCl<sub>3</sub>, CHCl<sub>3</sub> = 7.26 ppm):  $\delta$  6.89 – 6.83 (m, 1H, H-6), 6.28 (bs, 1H, NH), 6.10 (dq,  $J$  = 15.4, 1.6 Hz, 1H, H-7), 3.40 – 3.37 (m, 2H, H-2), 3.05 – 3.01 (m, 2H, H-1), 1.92 (s, 3H, Me-4), 1.86 – 1.83 (m, 3H, Me-8) ppm;

**<sup>13</sup>C-NMR** (400 MHz, CDCl<sub>3</sub> = 77.16 ppm):  $\delta$  190.0 (s, C-5), 170.5 (s, C-3), 141.7 (d, C-7), 129.9 (d, C-6), 39.7 (t, C-2), 28.1 (t, C-1), 23.1 (q, C-4), 18.0 (q, C-8);

**m.p.** 60 °C (lit. 61.5 – 62 °C)<sup>[215]</sup>;

**HRMS-ESI**  $m/z$  for C<sub>8</sub>H<sub>13</sub>NO<sub>2</sub>SNa [M+Na]<sup>+</sup> calc. 210.0565, found 210.0565.

### *S*-(2-Acetamidoethyl) (*E*)-2-methylbut-2-enethioate (**268**)

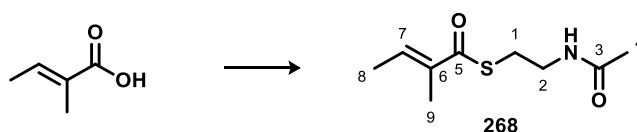

SNAC thioester **268** (293 mg, 1.45 mmol, 73%) was prepared following **GP1** using (*E*)-2-methylbut-2-enoic acid and was obtained as a colorless oil.

The analytical data are consistent with those reported in the literature.<sup>[214]</sup>

**<sup>1</sup>H-NMR** (400 MHz, CDCl<sub>3</sub>, CHCl<sub>3</sub> = 7.26 ppm):  $\delta$  6.85 (dq,  $J$  = 6.9, 1.1 Hz, 1H, H-7), 6.04 (bs, 1H, NH), 3.42 (dt,  $J$  = 6.1, 6.0 Hz 2H, H-2), 3.04 (t,  $J$  = 6.4 Hz, 2H, H-1), 1.95 (s, 3H, Me-4), 1.85 (s, 3H, Me-9), 1.82 (d,  $J$  = 6.9 Hz, 3H, Me-8) ppm;

**<sup>13</sup>C-NMR** (400 MHz, CDCl<sub>3</sub> = 77.16 ppm):  $\delta$  193.4 (s, C-5), 170.6 (s, C-3), 136.7 (d, C-7), 136.5 (s, C-6), 39.5 (t, C-2), 28.2 (t, C-1), 22.9 (q, C-4), 14.3 (q, C-9), 12.0 (q, C-8);

**HRMS-ESI**  $m/z$  for C<sub>9</sub>H<sub>15</sub>NO<sub>2</sub>SNa [M+Na]<sup>+</sup> calc. 224.0721, found 224.0721.

### *S*-(2-Acetamidoethyl) (*E*)-2-methylpent-2-enethioate (**269**)

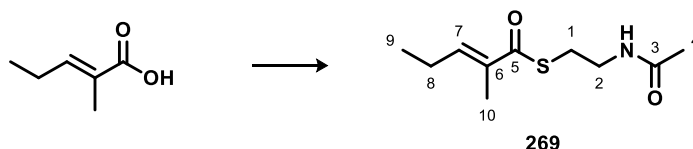

SNAC thioester **269** (272 mg, 1.26 mmol, 63%) was prepared following **GP1** using (*E*)-2-methylpent-2-enoic acid and was obtained as a colorless oil.

The analytical data are consistent with those reported in the literature.<sup>[214]</sup>

**<sup>1</sup>H-NMR** (400 MHz, CDCl<sub>3</sub>, CHCl<sub>3</sub> = 7.26 ppm):  $\delta$  6.74 (dt,  $J$  = 7.5, 1.1 Hz, 1H, H-7), 6.00 (bs, 1H, NH), 3.43 (q,  $J$  = 6.1 Hz, 2H, H-2), 3.05 (t,  $J$  = 6.4 Hz, 2H, H-1), 2.25 – 2.18 (m, 2H, H-8), 1.95 (s, 3H, Me-4), 1.86 (s, 3H, Me-10), 1.06 (t,  $J$  = 7.5 Hz, 3H, Me-9) ppm;

**<sup>13</sup>C-NMR** (400 MHz, CDCl<sub>3</sub> = 77.16 ppm):  $\delta$  194.1 (s, C-5), 170.8 (s, C-3), 143.6 (d, C-7), 135.3 (s, C-6), 40.0 (t, C-2), 28.3 (t, C-1), 23.2 (q, C-4), 22.2 (t, C-8), 13.0 (q, C-9), 12.4 (q, C-10);

**HRMS-ESI**  $m/z$  for C<sub>10</sub>H<sub>17</sub>NO<sub>2</sub>SNa [M+Na]<sup>+</sup> calc. 238.0878, found 238.0876.

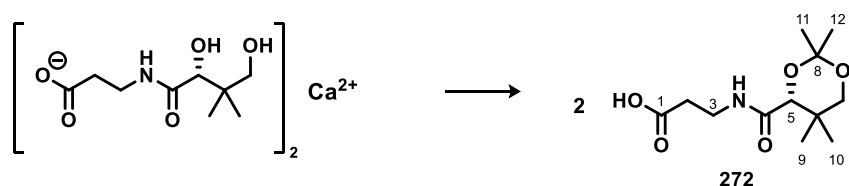
**(R)-3-(2,2,5,5-Tetramethyl-1,3-dioxane-4-carboxamido)propanoic acid (272)**

According to the procedure published by Townsend *et al.*<sup>[175]</sup> D-pantothenic acid hemicalcium salt (10.0 g, 20.98 mmol, 1.0 eq.), *p*-TsOH·1H<sub>2</sub>O (9.58 g, 50.36 mmol, 2.4 eq.) and molecular sieves (3 Å, pellets, 10.0 g) were suspended in reagent grade acetone (500 mL). The mixture was stirred at room temperature for 12 h before the thick slurry was filtered through a plug of Celite® and was washed with acetone (3 x 150 mL). The filtrate was concentrated to give a viscous oil which was dissolved in EtOAc (250 mL), washed with brine (2x 150 mL), dried over MgSO<sub>4</sub> and filtered. Most of the solvent was removed under reduced pressure and the product was precipitated by the addition of PE. The solid was filtered off and further dried under high vacuum to yield D-pantothenic dimethyl ketal (**272**, 7.72 g, 29.79 mmol, 71%) as colorless crystals.

The analytical data are consistent with those reported in the literature.<sup>[216]</sup>

**R<sub>f</sub>** = 0.4 (EtOAc/MeOH = 4:1);

**<sup>1</sup>H-NMR** (400 MHz, CDCl<sub>3</sub>, CHCl<sub>3</sub> = 7.26 ppm): δ 7.04 (t, *J* = 5.5 Hz, 1H, NH), 4.10 (s, 1H, H-5), 3.69 (d, *J* = 11.6 Hz, 1H, H-7), 3.67 – 3.56 (m, 1H, H3), 3.53 – 3.46 (m, 1H, H-3'), 3.28 (d, *J* = 11.7 Hz, 1H, H-7'), 2.62 (t, *J* = 6.2 Hz, 2H, H-2), 1.46 (s, 3H, Me-11/12), 1.42 (s, 3H, Me-11/12), 1.03 (s, 3H, Me-9/10), 0.97 (s, 3H, Me-9/10) ppm;

**<sup>13</sup>C-NMR** (400 MHz, CDCl<sub>3</sub>, CDCl<sub>3</sub> = 77.16 ppm): δ 176.5 (s, C-1), 170.4 (s, C-4), 99.2 (s, C-8), 77.2 (d, C-5), 71.5 (t, C-7), 34.2 (t, C-2), 33.9 (t, C-3), 33.1 (s, C-6), 29.5 (q, Me), 22.1 (q, Me), 18.9 (q, Me), 18.8 (q, Me) ppm;

[α]<sub>D</sub><sup>20</sup> = +100.1 (*c* = 1.0, MeOH; lit. [α]<sub>D</sub><sup>20</sup> = +104.0, *c* = 1.2; MeOH)<sup>[217]</sup>;

**m.p.** 89–91 °C (lit. 88–90 °C)<sup>[216]</sup>;

**HRMS-ESI** *m/z* for C<sub>12</sub>H<sub>21</sub>NO<sub>5</sub>Na [M+Na]<sup>+</sup> calc. 282.1312, found 282.1312.

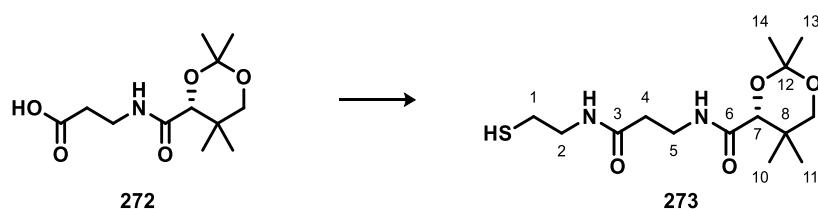
**(R)-N-(3-((2-Mercaptoethyl)amino)-3-oxopropyl)-2,2,5,5-tetramethyl-1,3-dioxane-4-carboxamide (273)**

According to the procedure published by Townsend *et al.*<sup>[175]</sup> freshly prepared D-pantothenic dimethyl ketal (**272**, 1.36 g, 5.25 mmol, 1.0 eq.) was dissolved in freshly distilled THF (30 mL), treated with CDI (1.28 g, 7.88 mmol, 1.5 eq.) and stirred at room temperature for

1 h. Cysteamine hydrochloride (0.90 g, 7.88 mmol, 1.5 eq.) was added and stirring was continued for 12 h. Most of the solvent was removed under reduced pressure and the resulting oil was dissolved in CH<sub>2</sub>Cl<sub>2</sub>. The organic phase was washed with a saturated aqueous NH<sub>4</sub>Cl solution and brine, dried over MgSO<sub>4</sub>, filtered and the solvent was removed under reduced pressure. The crude product was purified by flash column chromatography (PE/EtOAc = 3:1 → 100% EtOAc) to yield pantetheine dimethyl ketal **273** (1.45 g, 4.57 mmol, 87%) as a colorless solid.

The analytical data are consistent with those reported in the literature.<sup>[175,218]</sup>

**R<sub>f</sub>** = 0.2 (100% EtOAc);

**<sup>1</sup>H-NMR** (400 MHz, CDCl<sub>3</sub>, CHCl<sub>3</sub> = 7.26 ppm): δ 7.07 (bs, 1H, NH), 6.62 (bs, 1H, NH), 4.08 (s, 1H, H-7), 3.67 (d, *J* = 11.7 Hz, 1H, H-9), 3.61 – 3.50 (m, 2H, H-5), 3.48 – 3.36 (m, 2H, H-2), 3.27 (d, *J* = 11.7 Hz, 1H, H-9'), 2.66 (q, *J* = 6.8 Hz, 2H, H-1), 2.51 (t, *J* = 6.0 Hz, 2H, H-4), 1.45 (q, 3H, Me-13/14), 1.41 (q, 3H, Me-13/14), 1.03 (q, 3H, Me-10/11), 0.96 (q, 3H, Me-10/11) ppm;

**<sup>13</sup>C-NMR** (400 MHz, CDCl<sub>3</sub>, CDCl<sub>3</sub> = 77.16 ppm): δ 171.2 (s, C-3), 170.4 (s, C-6), 99.2 (s, C-12), 77.3 (d, C-7), 71.5 (t, C-9), 42.6 (t, C-2), 36.2 (t, C-4), 35.0 (t, C-5), 33.1 (s, C-8), 29.6 (q, Me), 24.6 (t, C-1), 22.2 (q, Me), 19.0 (q, Me), 18.8 (q, Me) ppm;

**[α]<sub>D</sub><sup>20</sup>** = +45.0 (*c* = 0.9, CHCl<sub>3</sub>; lit. **[α]<sub>D</sub><sup>20</sup>** = +48.0, *c* = 1.0, CHCl<sub>3</sub>)<sup>[218]</sup>;

**m.p.** 99–100 °C (lit. 99–101 °C)<sup>[218]</sup>;

**HRMS-ESI** *m/z* for C<sub>14</sub>H<sub>26</sub>N<sub>2</sub>O<sub>4</sub>SNa [M+Na]<sup>+</sup> calc. 341.1505, found 341.1506.

**(R)-S-(2-(3-(2,2,5,5-Tetramethyl-1,3-dioxane-4-carboxamido)propanamido)ethyl)ethanethioate (274)**

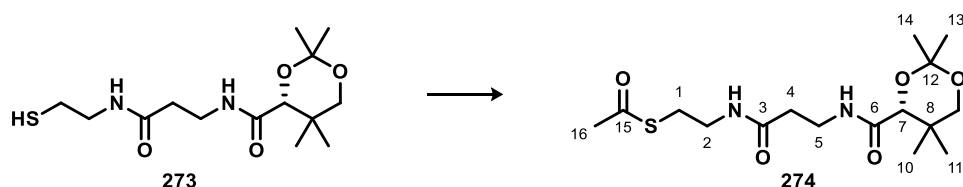

Acetyl pantetheine dimethyl ketal (**274**, 122 mg, 0.38 mmol, 78%) was prepared following **GP2** using acetic acid and was obtained as a colorless oil.

The analytical data are consistent with those reported in the literature.<sup>[214]</sup>

**<sup>1</sup>H-NMR** (400 MHz, CDCl<sub>3</sub>, CHCl<sub>3</sub> = 7.26 ppm): δ 7.02 (t, *J* = 6.3 Hz, 1H, NH), 6.60 (bs, 1H, NH), 4.03 (s, 1H, H-7), 3.63 (d, *J* = 11.7 Hz, 1H, H-9), 3.55 – 3.34 (m, 4H, H-2, H-5), 3.22 (d, *J* = 11.7 Hz, 1H, H-9'), 2.96 (t, *J* = 6.6 Hz, 2H, H-1), 2.40 (t, *J* = 6.2 Hz, 2H, H-4), 2.30 (s, 3H, Me-16), 1.41 (s, 3H, Me-13/14), 1.37 (s, 3H, Me-13/14), 0.98 (s, 3H, Me-10/11), 0.92 (s, 3H, Me-10/11) ppm;

**<sup>13</sup>C-NMR** (400 MHz, CDCl<sub>3</sub>, CDCl<sub>3</sub> = 77.16 ppm): δ 196.1 (s, C-15), 171.4 (s, C-3), 170.3 (s, C-6), 99.1 (s, C-12), 77.2 (d, C-7), 71.4 (t, C-9), 39.4 (t, C-2), 35.9 (t, C-4), 34.9 (t, C-5), 33.0 (s, C-8), 30.7 (q, C-16), 29.5 (q, C-13/14), 28.7 (t, C-1), 22.2 (q, C-10/11), 19.0 (q, C-10/11), 18.7 (q, C-13/14) ppm;

**HRMS-ESI** *m/z* for C<sub>16</sub>H<sub>28</sub>N<sub>2</sub>O<sub>5</sub>SNa [M+Na]<sup>+</sup> calc. 383.1617, found 383.1613.

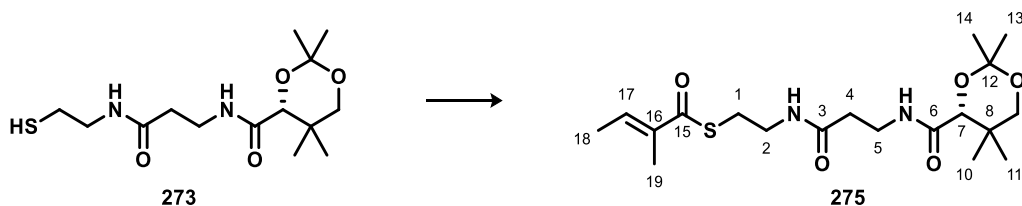
**(*R*)-*S*-(2-(3-(2,2,5,5-Tetramethyl-1,3-dioxane-4-carboxamido)propanamido)ethyl) (*E*)-2-methylbut-2-enethioate**

(*E*)-2-Methylbut-2-enoyl pantetheine dimethyl ketal (**275**, 143 mg, 0.40 mmol, 81%) was prepared following **GP2** using (*E*)-2-methylbut-2-enoic acid and was obtained as a colorless oil.

The analytical data are consistent with those reported in the literature.<sup>[214]</sup>

**<sup>1</sup>H-NMR** (400 MHz, CDCl<sub>3</sub>, CHCl<sub>3</sub> = 7.26 ppm): δ 7.02 (t, *J* = 5.7 Hz, 1H, NH), 6.81 – 6.76 (m, 1H, H-17), 6.64 (bs, 1H, NH), 4.01 (s, 1H, H-7), 3.61 (d, *J* = 11.6 Hz, 1H, H-9), 3.49 – 3.36 (m, 4H, H-2, H-5), 3.20 (d, *J* = 11.6 Hz, 1H, H-9'), 2.98 (t, *J* = 6.5 Hz, 2H, H-1), 2.37 (t, *J* = 6.2 Hz, 2H, H-4), 1.79 (s, 3H, H-19), 1.76 (d, *J* = 7.1 Hz, 3H, H-18), 1.38 (s, 3H, Me-13/14), 1.35 (s, 3H, Me-13/14), 0.95 (s, 3H, Me-10/11), 0.90 (s, 3H, Me-10/11) ppm;

**<sup>13</sup>C-NMR** (400 MHz, CDCl<sub>3</sub> = 77.16 ppm): δ 193.5 (s, C-15), 171.4 (s, C-3), 170.2 (s, C-6), 136.8 (d, C-17), 136.8 (q, C-16), 99.1 (s, C-12), 77.1 (d, C-7), 71.4 (t, C-9), 39.6 (t, C-2), 35.8 (t, C-4), 34.9 (t, C-5), 32.9 (s, C-8), 29.4 (q, C-13/14), 28.3 (t, C-1), 22.1 (q, C-10/11), 18.9 (q, C-10/11), 18.7 (q, C-13/14), 14.5 (q, C-18), 12.1 (q, C-19);

**HRMS-ESI** *m/z* for C<sub>19</sub>H<sub>32</sub>N<sub>2</sub>O<sub>5</sub>SNa [M+Na]<sup>+</sup> calc. 423.1921, found 423.1924.

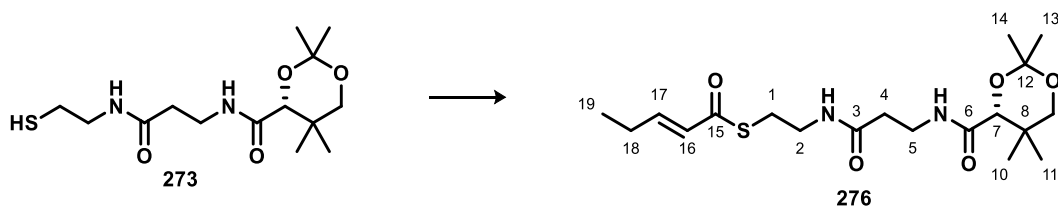
**(*R*)-*S*-(2-(3-(2,2,5,5-Tetramethyl-1,3-dioxane-4-carboxamido)propanamido)ethyl) (*E*)-pent-2-enethioate (**276**)**

(*E*)-Pent-2-enoyl pantetheine dimethyl ketal (**276**, 125 mg, 0.31 mmol, 64%) was prepared following **GP2** using (*E*)-pent-2-enoic acid and was obtained as a colorless oil.

**<sup>1</sup>H-NMR** (500 MHz, MeOD-d<sub>4</sub>, MeOH = 3.31 ppm): δ 8.22 (bs, 1H, NH), 7.65 (bs, 1H, NH), 6.98 (dt, *J* = 15.4, 6.5 Hz, 1H, H-17), 6.16 (dt, *J* = 15.5, 1.7 Hz, 1H, H-16), 4.12 (s, 1H, H-7), 3.73 (d, *J* = 11.7 Hz, 1H, H-9), 3.48 – 3.43 (m, 2H, H-2), 3.35 (t, *J* = 6.6 Hz, 2H, H-5), 3.26 (d, *J* = 11.6 Hz, 1H, H-9'), 3.06 (t, *J* = 6.6 Hz, 2H, H-1), 2.40 (t, *J* = 6.6 Hz, 2H, H-4), 2.28 – 2.21 (m, 2H, H-18), 1.45 (s, 3H, Me-13/14), 1.44 (s, 3H, Me-13/14), 1.07 (t, *J* = 7.4 Hz, 3H, H-19), 0.99 (s, 3H, Me-10/11), 0.97 (s, 3H, Me-10/11) ppm;

**<sup>13</sup>C-NMR** (500 MHz, MeOD-d<sub>4</sub>, MeOH = 49.00 ppm): δ 191.0 (s, C-15), 173.8 (s, C-3), 172.1 (s, C-6), 148.8 (d, C-17), 128.6 (d, C-16), 100.4 (s, C-12), 78.4 (d, C-7), 72.3 (t, C-9),

40.2 (t, C-2), 36.3 (t, C-4), 36.1 (t, C-5), 33.9 (s, C-8), 29.7 (q, C-13/14), 28.9 (t, C-1), 26.2 (t, C-18), 22.4 (q, C-10/11), 19.4 (q, C-10/11), 19.0 (q, C-13/14), 12.5 (q, C-19) ppm;

**HRMS-ESI**  $m/z$  for  $C_{19}H_{32}N_2O_5SNa$   $[M+Na]^+$  calc. 423.1930, found 423.1928.

**(R)-S-(2-(3-(2,4-Dihydroxy-3,3-dimethylbutanamido)propanamido)ethyl) ethanethioate (277)**

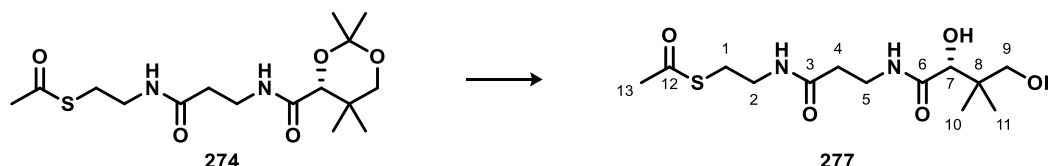

According to **GP3** acetonide **274** (56 mg, 0.156 mmol, 1.0 eq.) was treated with  $InCl_3$  (69 mg, 0.312 mmol, 2.0 eq.) and water (11  $\mu$ L, 0.625 mmol, 4.0 eq.). The crude product was purified by flash column chromatography ( $CH_2Cl_2/MeOH = 30:1 \rightarrow 15:1$ ) to yield acetyl pantetheine **277** (25 mg, 0.078 mmol, 50%) as a colorless oil.

The analytical data are consistent with those reported in the literature.<sup>[218]</sup>

**$^1H$ -NMR** (500 MHz,  $MeOD-d_4$ ,  $MeOH = 3.31$  ppm):  $\delta$  3.89 (s, 1H, H-7), 3.50 – 3.33 (m, 6H, H-2, H-5, H-9), 3.00 (t,  $J = 6.7$  Hz, 2H, H-1), 2.41 (t,  $J = 6.7$  Hz, 2H, H-4), 2.33 (s, 3H, Me-13), 0.92 (s, 6H, Me-10, Me-11) ppm;

**$^{13}C$ -NMR** (400 MHz,  $MeOD-d_4$ ,  $MeOH = 49.00$  ppm):  $\delta$  197.0 (s, C-12), 176.1 (s, C-6), 173.9 (s, C-3), 77.3 (d, C-7), 70.3 (t, C-9), 40.4 (s, C-2), 40.0 (t, C-8), 36.4 (t, C-4), 36.3 (t, C-5), 30.5 (q, C-13), 29.4 (t, C-1), 21.3 (q, C-10/11), 20.9 (q, C-10/11);

$[\alpha]_D^{20} = +19.2$  ( $c = 0.8$ ,  $MeOH$ ), lit.  $[\alpha]_D^{20} = +22.0$  ( $c = 1.0$ ,  $CHCl_3$ )<sup>[218]</sup>;

**HRMS-ESI**  $m/z$  for  $C_{13}H_{24}N_2O_5SNa$   $[M+Na]^+$  calc. 343.1304, found 343.1303.

**(R)-S-(2-(3-(2,4-Dihydroxy-3,3-dimethylbutanamido)propanamido)ethyl) (E)-2-methylbut-2-enethioate (278)**

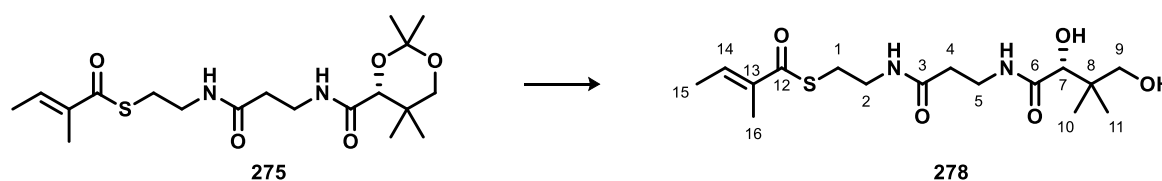

According to **GP3** acetonide **275** (75 mg, 0.187 mmol, 1.0 eq.) was treated with  $InCl_3$  (83 mg, 0.375 mmol, 2.0 eq.) and water (14  $\mu$ L, 0.749 mmol, 4.0 eq.). The crude product was purified by flash column chromatography ( $CH_2Cl_2/MeOH = 30:1 \rightarrow 15:1$ ) to yield (*E*)-2-methylbut-2-enoyl pantetheine **278** (35 mg, 0.097 mmol, 52%) as a colorless oil.

The analytical data are consistent with those reported in the literature.<sup>[214]</sup>

**$^1H$ -NMR** (500 MHz,  $MeOD-d_4$ ,  $MeOH = 3.31$  ppm):  $\delta$  6.88 (q,  $J = 6.6$  Hz, 1H, H-14), 3.89 (s, 1H, H-7), 3.50 – 3.33 (m, 6H, H-2, H-5, H-9), 3.03 (t,  $J = 6.7$  Hz, 2H, H-1), 2.41 (t,  $J = 6.6$  Hz, 2H, H-4), 1.85 (s, 3H, H-16), 1.84 (d,  $J = 7.5$  Hz, 3H, H-15), 0.92 (s, 6H, Me-10, Me-11) ppm;

$^{13}\text{C-NMR}$  (400 MHz, MeOD- $d_4$ , MeOH = 49.00 ppm):  $\delta$  194.4 (s, C-12), 176.1 (s, C-6), 173.9 (s, C-3), 138.2 (d, C-14), 137.6 (s, C-13), 77.3 (d, C-7), 70.3 (t, C-9), 40.4 (s, C-8), 40.2 (t, C-2), 36.4 (t, C-4), 36.3 (t, C-5), 29.0 (t, C-1), 21.3 (q, C-10), 21.0 (q, C-11), 14.4 (q, C-15), 12.1 (q, C-16) ppm;

$[\alpha]_{\text{D}}^{20} = +12.1$  ( $c = 0.9$ , MeOH);

**HRMS-ESI**  $m/z$  for  $\text{C}_{16}\text{H}_{28}\text{N}_2\text{O}_5\text{SNa}$   $[M+\text{Na}]^+$  calc. 383.1617, found 383.1616.

**(R)-S-(2-(3-(2,4-Dihydroxy-3,3-dimethylbutanamido)propanamido)ethyl) (E)-pent-2-enethioate (279)**

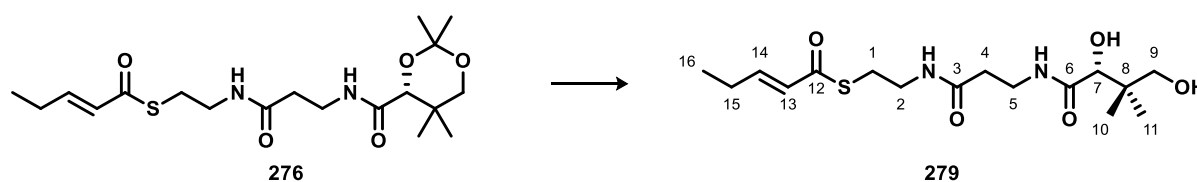

According to **GP3** acetonide **276** (83 mg, 0.207 mmol, 1.0 eq.) was treated with  $\text{InCl}_3$  (92 mg, 0.414 mmol, 2.0 eq.) and water (15  $\mu\text{L}$ , 0.829 mmol, 4.0 eq.). The crude product was purified by flash column chromatography ( $\text{CH}_2\text{Cl}_2/\text{MeOH} = 30:1 \rightarrow 15:1$ ) to yield (E)-pent-2-enoyl pantetheine **279** (42 mg, 0.117 mmol, 56%) as a colorless oil.

$^1\text{H-NMR}$  (500 MHz, MeOD- $d_4$ , MeOH = 3.31 ppm):  $\delta$  6.89 (dt,  $J = 15.4, 6.5$  Hz, 1H, H-14), 6.16 (dt,  $J = 15.5, 1.7$  Hz, 1H, H-13), 3.89 (s, 1H, H-7), 3.53 – 3.33 (m, 6H, H-2, H-5, H-9), 3.06 (t,  $J = 6.7$  Hz, 2H, H-1), 2.41 (t,  $J = 6.7$  Hz, 2H, H-2), 2.29 – 2.21 (m, 2H, H-15), 1.08 (t,  $J = 7.4$  Hz, 3H, H-16), 0.92 (s, 6H, H-10, H-11) ppm;

$^{13}\text{C-NMR}$  (400 MHz, MeOD- $d_4$ , MeOH = 49.00 ppm):  $\delta$  191.2 (s, C-12), 176.0 (s, C-6), 173.9 (s, C-3), 148.8 (d, C-14), 128.6 (d, C-13), 77.3 (d, C-7), 70.4 (t, C-9), 40.4 (t, C-8), 40.2 (s, C-2), 36.4 (t, C-4), 36.4 (t, C-5), 28.9 (t, C-1), 26.2 (t, C-15), 21.4 (q, C-10/11), 20.9 (q, C-10/11), 12.5 (q, C-16);

$[\alpha]_{\text{D}}^{20} = +22.7$  ( $c = 2.3$ , MeOH);

**HRMS-ESI**  $m/z$  for  $\text{C}_{16}\text{H}_{28}\text{N}_2\text{O}_5\text{SNa}$   $[M+\text{Na}]^+$  calc. 383.1617, found 383.1617.

**N-Acetyethylenediamine (281)**

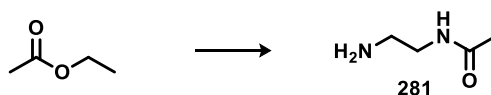

$\text{EtOAc}$  (1.0 mL, 10.0 mmol, 1.0 eq.) was diluted in MeOH (25 mL) and ethylenediamine (2.70 mL, 40.0 mmol, 4.0 eq.) was added. Stirring was continued at room temperature for 4 days. All volatiles were removed under reduced pressure to afford N-acetyethylenediamine (**281**, 912 mg, 8.94 mmol, 90%) as a pale yellow solid.

The analytical data are consistent with those reported in the literature.<sup>[219,220]</sup>

$^1\text{H-NMR}$  (400 MHz,  $\text{CDCl}_3$ ,  $\text{CHCl}_3 = 7.26$  ppm):  $\delta$  6.50 (s, 1H, NH), 3.22 (q,  $J = 5.8$  Hz, 2H,  $\text{NHCH}_2$ ), 2.76 (t,  $J = 5.9$  Hz, 2H,  $\text{NH}_2\text{CH}_2$ ), 1.93 (s, 3H,  $\text{CH}_3$ ), 1.28 (bs, 2H,  $\text{NH}_2$ ) ppm;

**m.p.** 51  $^\circ\text{C}$  (lit. 51  $^\circ\text{C}$ )<sup>[219]</sup>.

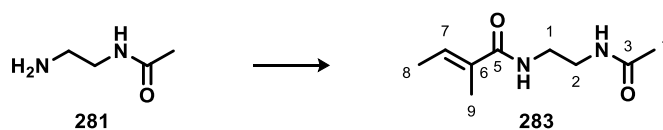

**(E)-N-(2-Acetamidoethyl)-2-methylbut-2-enamide (283)**

Tiglic acid (48 mg, 0.485 mmol, 1.5 eq.) was dissolved in  $\text{CH}_2\text{Cl}_2$  (2 mL) and *N*-acetyleneethylenediamine (**281**, 33 mg, 0.323 mmol, 1.0 eq.) as a solution in  $\text{CH}_2\text{Cl}_2$  (1 mL) was added. The mixture was cooled to 0 °C and EDC·HCl (93 mg, 0.485 mmol, 1.5 eq.) and HOBT (74 mg, 0.485 mmol, 1.5 eq.) was added. The reaction was allowed to reach room temperature and stirring was continued overnight. The reaction was terminated by the addition of an aqueous 2 M HCl solution. The phases were separated and the aqueous phase was extracted with  $\text{CH}_2\text{Cl}_2$  (3 x 2 mL). The combined organic phases were washed with aqueous saturated  $\text{NaHCO}_3$  solution, brine, dried over  $\text{MgSO}_4$ , filtered and the solvent was removed under reduced pressure. The crude product was purified by flash column chromatography (2-5% MeOH/ $\text{CH}_2\text{Cl}_2$ ) to furnish amide **283** (10 mg, 0.054 mmol, 17%) as a colorless oil.

$R_f$  = 0.7 (100% EtOAc);

$^1\text{H-NMR}$  (400 MHz,  $\text{CDCl}_3$ ,  $\text{CHCl}_3$  = 7.26 ppm):  $\delta$  6.78 (bs, 2H, NH), 6.48 (dq, d,  $J$  = 6.9, 1.3 Hz, 1H, H-7), 3.47 – 3.38 (m, 4H, H-1, H-2), 1.98 (s, 3H, Me-4), 1.82 – 1.81 (m, 3H, Me-9), 7.85 (dd, d,  $J$  = 8.2 Hz, 3H, Me-8) ppm;

**HRMS-ESI**  $m/z$  for  $\text{C}_9\text{H}_{16}\text{N}_2\text{O}_2\text{Na}$  [ $\text{M}+\text{Na}$ ] $^+$  calc. 207.1110, found 207.1110.

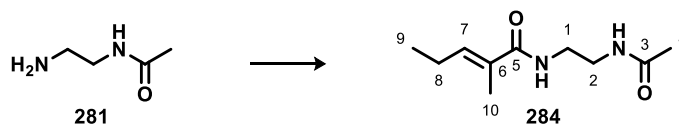
**(E)-N-(2-Acetamidoethyl)-2-methylpent-2-enamide (284)**

2-Methyl-2-pentenoic acid (49 mg, 0.429 mmol, 1.2 eq.) and *N*-acetyleneethylenediamine (**281**, 37 mg, 0.357 mmol, 1.0 eq.) were dissolved in  $\text{CH}_2\text{Cl}_2$  (5 mL) and cooled to 0 °C. Subsequently, EDC·HCl (82 mg, 0.428 mmol, 1.2 eq.) and DMAP (9 mg, 0.072 mmol, 0.2 eq.) were added and the ice-bath was removed. Stirring was continued for 3 h before the reaction was terminated by the addition of an aqueous 2 M HCl solution. The phases were separated and the aqueous phase was extracted with  $\text{CH}_2\text{Cl}_2$  (3 x 5 mL). The combined organic phases were washed with aqueous saturated  $\text{NaHCO}_3$  solution, brine, dried over  $\text{MgSO}_4$ , filtered and the solvent was removed under reduced pressure. The crude product was purified by flash column chromatography (2-5% MeOH/ $\text{CH}_2\text{Cl}_2$ ) to furnish amide **284** (12 mg, 0.061 mmol, 17%) as a colorless oil.

$R_f$  = 0.8 (100% EtOAc);

$^1\text{H-NMR}$  (400 MHz,  $\text{CDCl}_3$ ,  $\text{CHCl}_3$  = 7.26 ppm):  $\delta$  6.44 (bs, 1H, NH), 6.39 (dt,  $J$  = 7.3, 1.2 Hz, 1H, H-7), 6.26 (bs, 1H, NH), 3.45 – 3.43 (m, 4H, H-1, H-2), 2.20 – 2.12 (m, 2H, H-8), 1.99 (s, 3H, Me-4), 1.84 (s, 3H, Me-10), 1.04 (t,  $J$  = 7.6 Hz, 3H, Me-9) ppm;

**HRMS-ESI**  $m/z$  for  $\text{C}_{10}\text{H}_{18}\text{N}_2\text{O}_2\text{Na}$  [ $\text{M}+\text{Na}$ ] $^+$  calc. 221.1266, found 221.1267.

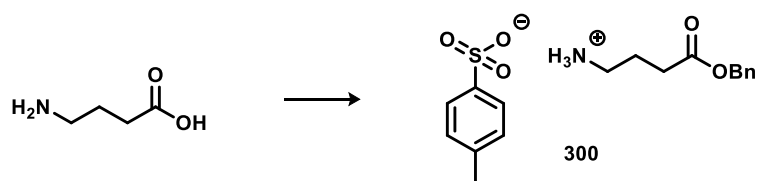
**4-(Benzyloxy)-4-oxobutan-1-aminium 4-methylbenzenesulfonate (300)**

$\gamma$ -Aminobutyric acid (436 mg, 4.23 mmol, 1.0 eq.), benzyl alcohol (2.10 mL, 20.29 mmol, 4.8 eq.) and *p*TsOH·1H<sub>2</sub>O (801 mg, 4.65 mmol, 1.1 eq.) were suspended in PhMe (14 mL). The mixture was stirred under refluxing conditions for 5 h removing water azeotropically applying a Dean-Stark apparatus. After the mixture cooled down to room temperature crystallization was initiated by the addition of Et<sub>2</sub>O. The solids were filtered off and recrystallized from MeOH and Et<sub>2</sub>O. The colorless solid was again filtered off and dried in an open beaker for 2 days to furnish toluene sulfonate **300** (1.22 g, 3.35 mmol, 79%) as a colorless free flowing solid.

The analytical data are consistent with those reported in the literature.<sup>[221]</sup>

<sup>1</sup>H-NMR (400 MHz, CDCl<sub>3</sub>, CHCl<sub>3</sub> = 7.26 ppm):  $\delta$  7.72 (d, 2H, H<sub>Ar</sub>), 7.25 – 7.31 (m, 5H, Bn), 7.06 (d, 2H, H<sub>Ar</sub>), 5.19 (s, 2H, Bn), 2.85 (t, 2H, -CH<sub>2</sub>N), 2.29 (m, 5H, -CH<sub>2</sub>CO, CH<sub>3</sub>Ph), 1.86 (q, 2H, -CH<sub>2</sub>CH<sub>2</sub>CO);

**m.p.** 105 °C (lit. 106.5 – 107 °C)<sup>[221]</sup>;

**HRMS-ESI** *m/z* for C<sub>29</sub>H<sub>39</sub>N<sub>2</sub>O<sub>7</sub>S [2M·*p*TsOH+H]<sup>+</sup> calc. 559.2478, found 559.2476.

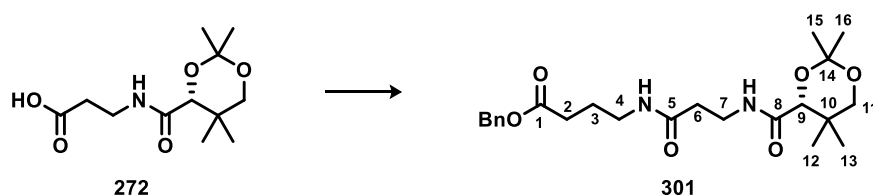
**Benzyl (R)-4-(3-(2,2,5,5-tetramethyl-1,3-dioxane-4 carboxamido)propanamido)butanoate (301)**

D-Pantothenic dimethyl ketal (**272**, 627 mg, 2.42 mmol, 1.0 eq.), HOBt·1H<sub>2</sub>O (407 mg, 2.66 mmol, 1.1 eq.) and EDC·HCl (556 mg, 2.90 mmol, 1.2 eq.) were dissolved in CH<sub>2</sub>Cl<sub>2</sub> (25 mL) and stirred at room temperature for 30 min. Toluene sulfonate **300** (884 mg, 2.42 mmol, 1.0 eq.) and DIPEA (1.05 mL, 6.05 mmol, 2.5 eq.) were added and the mixture was stirred at room temperature for 24 h. Upon complete consumption of the starting material (monitored by LCMS) the reaction was terminated by the addition of an aqueous 0.5 M NaOH solution. The phases were separated and the aqueous phase was extracted with CH<sub>2</sub>Cl<sub>2</sub> (3 x 15 mL). The combined organic phases were washed with a saturated aqueous NH<sub>4</sub>Cl solution, dried over MgSO<sub>4</sub>, filtered and the solvent was removed under reduced pressure. The crude product was purified by flash column chromatography (CH<sub>2</sub>Cl<sub>2</sub>/MeOH/PhMe = 94:4:2) to yield compound **301** (990 mg, 2.28 mmol, 94%) as a colorless solid.

**R<sub>f</sub>** = 0.2 (CH<sub>2</sub>Cl<sub>2</sub>/MeOH/PhMe = 94:4:2);

**<sup>1</sup>H-NMR** (400 MHz, CDCl<sub>3</sub>, CHCl<sub>3</sub> = 7.26 ppm): δ 7.38 – 7.31 (m, 5H, Bn), 7.03 (bs, 1H, -NH-C8), 6.21 (bs, 1H, -NH-C5), 5.11 (s, 2H, Bn), 4.06 (s, 1H, H-9), 3.66 (d, *J* = 11.7 Hz, 1H, H-11), 3.58 – 3.46 (m, 2H, H-7), 3.33 – 3.23 (m, 3H, H-4, H-11'), 2.42 – 2.38 (m, 4H, H-2, H-6), 1.88 – 1.82 (m, 2H, H-3), 1.44 (s, 3H, Me), 1.40 (s, 3H, Me), 1.02 (s, 3H, Me), 0.95 (s, 3H, Me) ppm;

**<sup>13</sup>C-NMR** (400 MHz, CDCl<sub>3</sub>, CDCl<sub>3</sub> = 77.16 ppm): δ 173.2 (s, C-1), 171.2 (s, C-5), 170.3 (s, C-8), 135.9 (s, Bn), 129.1 (d, Bn), 128.7 (d, 2C, Bn), 128.4 (d, Bn), 128.4 (d, 2C, Bn), 99.2 (s, C-14), 77.2 (d, C-9, under solvent peak), 71.5 (t, C-11), 66.5 (t, Bn), 39.0 (t, C-4), 36.1 (t, C-6), 34.9 (t, C-7), 33.1 (s, C-10), 31.8 (t, C-2), 29.6 (q, Me), 24.7 (t, C-3), 22.2 (q, Me), 19.0 (q, Me), 18.8 (q, Me) ppm;

$[\alpha]_{\text{D}}^{25} = +35.1$  (*c* = 1.1, CHCl<sub>3</sub>);

**m.p.** 81–83 °C;

**HRMS-ESI** *m/z* for C<sub>23</sub>H<sub>34</sub>N<sub>2</sub>O<sub>6</sub>Na [M+Na]<sup>+</sup> calc. 457.2315, found 457.2318.

**(R)-4-(3-(2,2,5,5-Tetramethyl-1,3-dioxane-4-carboxamido)propanamido)butanoic acid (290)**

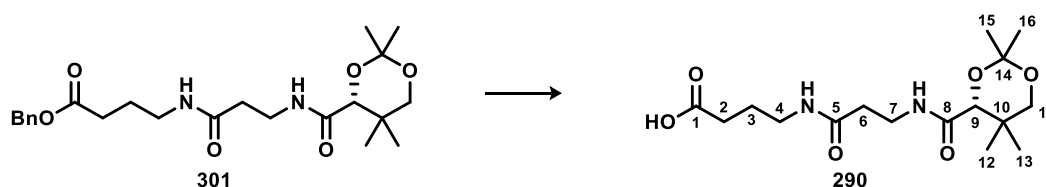

Benzyl ester **301** (76 mg, 0.175 mmol, 1.0 eq.) was dissolved in a mixture of EtOAc/EtOH (3.5:1, 4.5 mL) and Pd/C (10%, 19 mg, 17.5 μmol, 10 mol%) was added. A balloon filled with hydrogen gas was applied and the atmosphere was exchanged three times. The reaction was stirred at room temperature for 1 h before it was filtered through Celite<sup>®</sup> and rinsed with methanol. The solvent was removed under reduced pressure to furnish carboxylic acid **290** (54 mg, 0.156 mmol, 89%) as a colorless gum without further purification.

**R<sub>f</sub>** = 0.1 (5% MeOH/CH<sub>2</sub>Cl<sub>2</sub>);

**<sup>1</sup>H-NMR** (400 MHz, CDCl<sub>3</sub>, CHCl<sub>3</sub> = 7.26 ppm): δ 7.11 (bs, 1H, NH), 6.67 (bs, 1H, NH), 4.09 (s, 1H, H-9), 3.68 (d, *J* = 12.0 Hz, 1H, H-11), 3.54 (bs, 2H, H-7), 3.38 – 3.25 (m, 2H, H-4), 3.28 (d, *J* = 11.6 Hz, 1H, H-11'), 2.49 (bs, 2H, H-6), 2.39 (t, *J* = 6.8 Hz, 2H, H-2), 1.89 – 1.82 (m, 2H, H-3), 1.48 (s, 3H, Me), 1.42 (s, 3H, Me), 1.02 (s, 3H, Me), 0.96 (s, 3H, Me) ppm;

$[\alpha]_{\text{D}}^{25} = +28.3$  (*c* = 0.8, CHCl<sub>3</sub>);

**HRMS-ESI** *m/z* for C<sub>16</sub>H<sub>27</sub>N<sub>2</sub>O<sub>6</sub> [M-H]<sup>-</sup> calc. 343.1874, found 343.1875.

**1,3-Dioxoisindolin-2-yl (*R*)-4-(3-(2,2,5,5-tetramethyl-1,3-dioxane-4-carboxamido)propanamido)butanoate (**289**)**

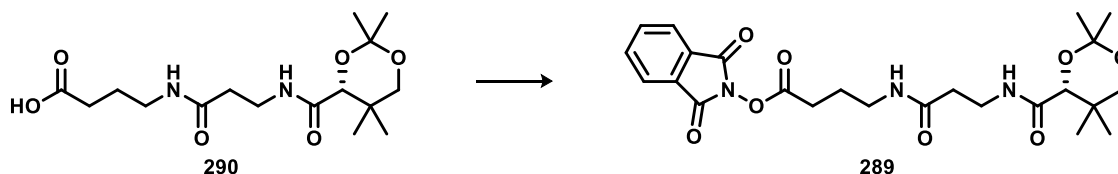

A flask was charged with acid **290** (27 mg, 0.078 mmol, 1.0 eq.) and *N*-hydroxyphthalimide (13 mg, 0.082 mmol, 1.05 eq.). The atmosphere was changed by evacuating and backfilling with argon (3x). CH<sub>2</sub>Cl<sub>2</sub> (500 μL) was added and the mixture was stirred vigorously. Then DIC (13 μL, 0.086 mmol, 1.1 eq.) was added dropwise via syringe and stirring was continued at room temperature for 2 h. Consumption of the starting material was monitored by LCMS. The solvent was removed under reduced pressure and the redox-active ester **289** was directly used in the next step without further purification.

**(*R,E*)-2,2,5,5-Tetramethyl-*N*-(3-((5-methyl-4-oxohept-5-en-1-yl)amino)-3-oxopropyl)-1,3-dioxane-4-carboxamide (**302**)**

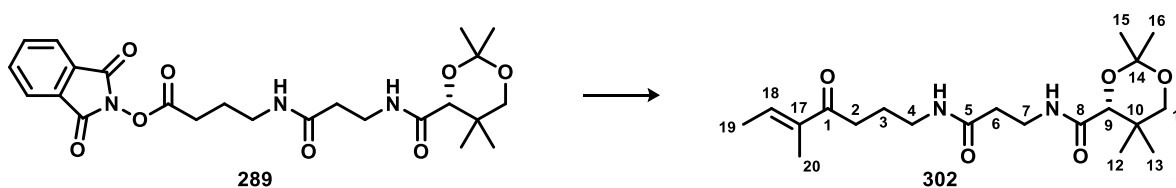

Freshly prepared redox-active ester **289** (38 mg, 0.078 mmol, 1.0 eq.) was dried under high vacuum for 15 min prior to use. Next, (*E*)-2-methylbut-2-enoic acid (16 mg, 0.157 mmol, 2.0 eq.), Ni(BPhen)Cl<sub>2</sub>·2DMF (7 mg, 0.016 mmol, 0.2 eq.), Zn (dust, 15 mg, 0.236 mmol, 3.0 eq.), benzoic anhydride (39 mg, 0.173 mmol, 2.2 eq.), MgCl<sub>2</sub> (anhydrous, 11 mg, 0.118 mmol, 1.5 eq.) and LiBr (7 mg, 0.078 mmol, 1.0 mmol) were added to the flask and the atmosphere was changed by evacuating and backfilling with argon (3x). MeCN/THF (degassed by *fpt*<sup>21</sup>, 3 cycles, 1:1.5, 1 mL) was added and the resulting dark red-brown mixture was stirred at room temperature for 14 h. The reaction mixture was diluted with EtOAc and washed with an aqueous 1 M HCl solution and an aqueous 1 M K<sub>2</sub>CO<sub>3</sub> solution and dried over MgSO<sub>4</sub>, filtered and the solvent was removed under reduced pressure. The crude product was purified by flash column chromatography (2% MeOH/CH<sub>2</sub>Cl<sub>2</sub>) to yield compound **302** (11 mg, 0.029 mmol, 37% o2s) as a colorless gum, which was of sufficient purity to be used in the next step.

**R<sub>f</sub>** = 0.1 (1% MeOH/CH<sub>2</sub>Cl<sub>2</sub>);

**<sup>1</sup>H-NMR** (400 MHz, CDCl<sub>3</sub>, CHCl<sub>3</sub> = 7.26 ppm): δ 7.03 (bs, 1H, NH), 6.75 (q, *J* = 6.8 Hz, 1H, H-18), 6.14 (bs, 1H, NH), 4.06 (s, 1H, H-9), 3.69 – 3.66 (m, 1H, H-11), 3.60 – 3.46 (m, 2H, H-7), 3.34 – 3.19 (m, 3H, H-4, H-11'), 2.70 (t, *J* = 7.0 Hz, 2H, H-2), 2.42 – 2.39 (m, 2H,

<sup>21</sup> Freeze-pump-thaw

H-6), 1.85 (d,  $J = 6.8$  Hz, 3H, H-19), 1.81 (t,  $J = 7.0$  Hz, 2H, H-3), 1.76 (s, 3H, H-20), 1.45 (s, 3H, Me), 1.41 (s, 3H, Me), 1.03 (s, 3H, Me), 0.96 (s, 3H, Me) ppm;

$^{13}\text{C-NMR}$  (400 MHz,  $\text{CDCl}_3$ ,  $\text{CDCl}_3 = 77.16$  ppm):  $\delta$  201.3 (s, C-1), 171.2 (s, C-5), 170.3 (s, C-8), 138.3 (s, C-17), 137.9 (d, C-18), 99.2 (s, C-14), 77.3 (d, C-9), 71.6 (t, C-11), 39.5 (t, C-4), 36.3 (t, C-6), 35.0 (t, C-7), 34.7 (t, C-2), 33.1 (s, C-10), 29.6 (q, Me), 24.3 (t, C-3), 22.3 (q, Me), 19.0 (q, Me), 18.8 (q, Me), 14.9 (q, C-19), 11.2 (q, C-20) ppm;

$[\alpha]_{\text{D}}^{23} = +21.8$  ( $c = 0.8$ ,  $\text{CH}_2\text{Cl}_2$ );

**HRMS-ESI**  $m/z$  for  $\text{C}_{20}\text{H}_{34}\text{N}_2\text{O}_5\text{Na}$   $[\text{M}+\text{Na}]^+$  calc. 405.2365, found 405.2369.

**(*R,E*)-2,4-Dihydroxy-3,3-dimethyl-*N*-(3-((5-methyl-4-oxohept-5-en-1-yl)amino)-3-oxopropyl)butanamide (285)**

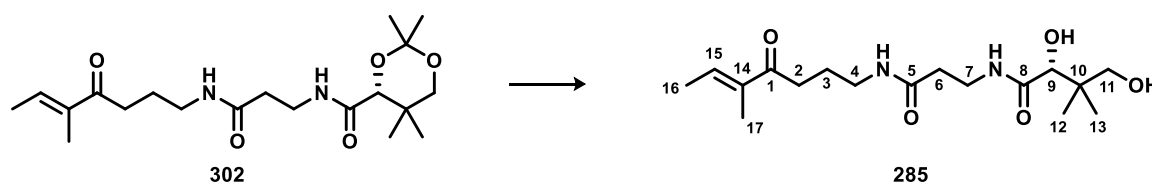

Acetonide **302** (9.7 mg, 25.4  $\mu\text{mol}$ , 1.0 eq.) was dissolved in MeCN (800  $\mu\text{L}$ ),  $\text{InCl}_3$  (11.2 mg, 50.7  $\mu\text{mol}$ , 2.0 eq.) was added, followed by water (1.8  $\mu\text{L}$ , 101.4  $\mu\text{mol}$ , 4.0 eq.) and stirring was continued at room temperature for 16 h. Water (3 mL) and  $\text{CH}_2\text{Cl}_2$  (5 mL) was added. The phases were separated and the aqueous phase was extracted with  $\text{CH}_2\text{Cl}_2$  (3 x 5 mL). The combined organic phases were dried over  $\text{MgSO}_4$ , filtered and the solvent was removed under reduced pressure. The crude product was purified by flash column chromatography ( $\text{CH}_2\text{Cl}_2/\text{MeOH} = 20:1 \rightarrow 10:1$ ) to yield “carba” pantetheine derivative **285** (3.3 mg, 9.6  $\mu\text{mol}$ , 38%) as a colorless oil.

$R_f = 0.4$  ( $\text{CH}_2\text{Cl}_2/\text{MeOH} = 9:1$ );

$^1\text{H-NMR}$  (600 MHz,  $\text{MeOD-d}_4$ , MeOH = 3.31 ppm):  $\delta$  6.89 (dq,  $J = 1.3, 6.9$  Hz, 1H, H-15), 3.88 (s, 1H, H-9), 3.52 – 3.43 (m, 4H, H-7, H-11), 3.18 (t,  $J = 6.9$  Hz, 2H, H-4), 2.73 (t,  $J = 7.3$  Hz, 2H, H-2), 2.41 (t,  $J = 6.7$  Hz, 2H, H-6), 1.88 (dd,  $J = 1.1, 6.9$  Hz, 3H, H-16), 1.76 (t,  $J = 7.2$  Hz, 2H, H-2), 1.76 (s, 3H, H-17), 0.91 (s, 6H, H-12, H-13) ppm;

$^{13}\text{C-NMR}$  (600 MHz,  $\text{MeOD-d}_4$ , MeOH = 49.00 ppm):  $\delta$  201.9 (s, C-1), 174.7 (s, C-5), 172.3 (s, C-8), 138.2 (d, C-15), 137.6 (s, C-14), 75.9 (d, C-9), 69.0 (t, C-11), 39.0 (t, C-4), 38.6 (t, C-6), 35.1 (t, C-2), 35.0 (t, C-7), 33.8 (s, C-10), 24.2 (t, C-3), 19.9 (q, C-12), 19.5 (q, C-13), 13.4 (q, C-16), 9.6 (q, C-17) ppm;

$[\alpha]_{\text{D}}^{25} = +8.3$  ( $c = 0.3$ , MeOH);

**HRMS-ESI**  $m/z$  for  $\text{C}_{17}\text{H}_{30}\text{N}_2\text{O}_5\text{Na}$   $[\text{M}+\text{Na}]^+$  calc. 365.2053, found 365.2053.

**(*R,E*)-2,2,5,5-Tetramethyl-*N*-(3-((5-methyl-4-oxooct-5-en-1-yl)amino)-3-oxopropyl)-1,3-dioxane-4-carboxamide (303)**

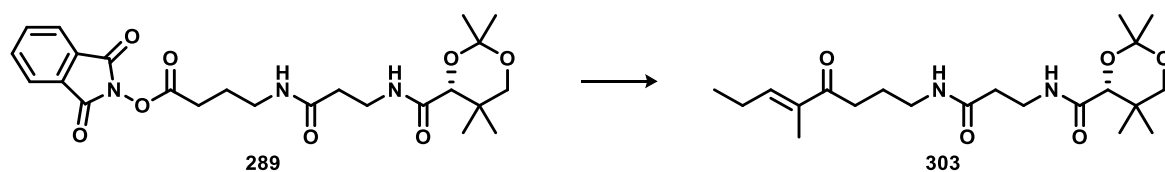

Freshly prepared redox-active ester **289** (31 mg, 62.0  $\mu\text{mol}$ , 1.0 eq.) was dried under high vacuum for 15 min prior to use. Next, (*E*)-2-methylpent-2-enoic acid (14 mg, 125.0  $\mu\text{mol}$ , 2.0 eq.), Ni(BPhen)Cl<sub>2</sub>·2DMF (6 mg, 13.0  $\mu\text{mol}$ , 0.2 eq.), Zn (dust, 12 mg, 187.0  $\mu\text{mol}$ , 3.0 eq.), benzoic anhydride (31 mg, 137.0  $\mu\text{mol}$ , 2.2 eq.), MgCl<sub>2</sub> (anhydrous, 9 mg, 94.0  $\mu\text{mol}$ , 1.5 eq.) and LiBr (5 mg, 62.0  $\mu\text{mol}$ , 1.0 mmol) were added to the flask and the atmosphere was changed by evacuating and backfilling with argon (3x). MeCN/THF (degassed by *fpt*, 3 cycles, 1:1.5, 600  $\mu\text{L}$ ) was added and the resulting dark red-brown mixture was stirred at room temperature for 14 h. The reaction mixture was diluted with EtOAc and washed with an aqueous 1 M HCl solution and an aqueous 1 M K<sub>2</sub>CO<sub>3</sub> solution and dried over MgSO<sub>4</sub>, filtered and the solvent was removed under reduced pressure. The crude product was purified by flash column chromatography (2% MeOH/CH<sub>2</sub>Cl<sub>2</sub>) to yield compound **303** (8.6 mg, 21.7  $\mu\text{mol}$ , 35% o2s) as a colorless oil which was used in the next step without further analysis.

$R_f = 0.1$  (1% MeOH/CH<sub>2</sub>Cl<sub>2</sub>);

HRMS-ESI  $m/z$  for C<sub>21</sub>H<sub>36</sub>N<sub>2</sub>O<sub>5</sub>Na [M+Na]<sup>+</sup> calc. 419.2522, found 419.2520.

**(*R,E*)-2,4-Dihydroxy-3,3-dimethyl-*N*-(3-((5-methyl-4-oxooct-5-en-1-yl)amino)-3-oxopropyl)butanamide (286)**

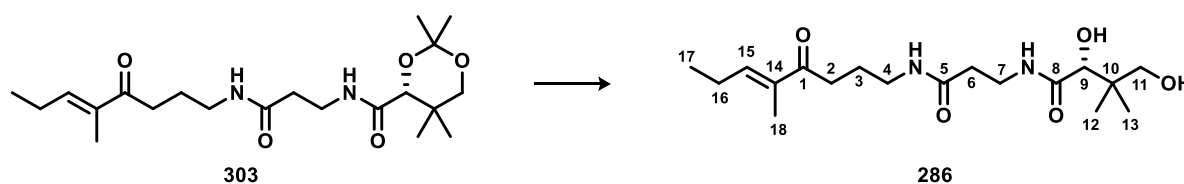

Acetonide **303** (8.6 mg, 21.7  $\mu\text{mol}$ , 1.0 eq.) was dissolved in MeCN (1 mL), InCl<sub>3</sub> (21 mg, 94.3  $\mu\text{mol}$ , 2.0 eq.) was added, followed by water (3.4  $\mu\text{L}$ , 188.6  $\mu\text{mol}$ , 4.0 eq.) and stirring was continued at room temperature for 16 h. Water (3 mL) and CH<sub>2</sub>Cl<sub>2</sub> (5 mL) was added. The phases were separated and the aqueous phase was extracted with CH<sub>2</sub>Cl<sub>2</sub> (3 x 5 mL). The combined organic phases were dried over MgSO<sub>4</sub>, filtered and the solvent was removed under reduced pressure. The crude product was purified by flash column chromatography (CH<sub>2</sub>Cl<sub>2</sub>/MeOH = 20:1  $\rightarrow$  10:1) to yield “carba” pantetheine derivative **286** (2.7 mg, 7.6  $\mu\text{mol}$ , 35%) as a colorless oil.

$R_f = 0.4$  (CH<sub>2</sub>Cl<sub>2</sub>/MEOH = 10:1);

**<sup>1</sup>H-NMR** (500 MHz, MeOD-d<sub>4</sub>, MeOH = 3.31 ppm):  $\delta$  6.76 (t,  $J$  = 6.8 Hz, 1H, H-15), 3.89 (s, 1H, H-9), 3.54 – 3.42 (m, 4H, H-7, H-11), 3.18 (t,  $J$  = 7.0 Hz, 2H, H-4), 2.75 (t,  $J$  = 7.3 Hz, 2H, H-2), 2.41 (t,  $J$  = 6.6 Hz, 2H, H-6), 2.33 – 2.25 (m, 2H, H-16), 1.80 – 1.73 (m, 5H, H-3, H-18), 1.09 (t,  $J$  = 7.6 Hz, 3H, H-17), 0.91 (s, 6H, H-12, H-13) ppm;

**<sup>13</sup>C-NMR** (500 MHz, MeOD-d<sub>4</sub>, MeOH = 49.00 ppm):  $\delta$  202.1 (s, C-1), 174.7 (s, C-5), 172.3 (s, C-8), 144.8 (d, C-15), 136.1 (s, C-14), 75.8 (d, C-9), 69.0 (t, C-11), 39.0 (t, C-4), 38.6 (t, C-6), 35.1 (t, C-2), 35.0 (t, C-7), 33.8 (s, C-10), 24.2 (t, C-3), 21.9 (t, C-16), 19.9 (q, C-12), 19.5 (q, C-13), 11.9 (q, C-17), 9.8 (q, C-18) ppm;

$[\alpha]_D^{24} = + 8.0$  ( $c$  = 0.2, MeOH);

**HRMS-ESI**  $m/z$  for C<sub>18</sub>H<sub>32</sub>N<sub>2</sub>O<sub>5</sub>Na [M+Na]<sup>+</sup> calc. 379.2209, found 379.2212.

**(3S,4S)-7-((*tert*-Butyldimethylsilyl)oxy)-4-methoxy-2-methylhept-1-en-3-yl acetate (309)**

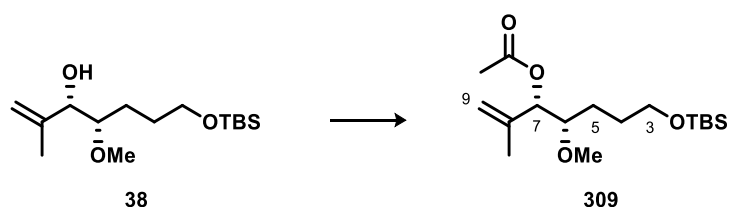

Alcohol **38** (375 mg, 1.30 mmol, 1.0 eq.) was dissolved in Ac<sub>2</sub>O (4.50 mL) and pyridine (4.50 mL). DMAP (40 mg, 0.390 mmol, 0.3 eq.) was added and the reaction was stirred overnight. The reaction was terminated by the addition of an aqueous 1 M CuSO<sub>4</sub> solution. The phases were separated and the aqueous phase was extracted with Et<sub>2</sub>O (3 x 10 mL). The combined organic phases were washed with brine, dried over MgSO<sub>4</sub>, filtered and the solvent was removed under reduced pressure. The crude product was purified by flash column chromatography (PE/EtOAc = 8:1) to yield acetate **309** (338 mg, 1.02 mmol, 78%) as a colorless oil.

$R_f$  = 0.6 (PE/EtOAc = 4:1);

**<sup>1</sup>H-NMR** (400 MHz, CDCl<sub>3</sub>, CHCl<sub>3</sub> = 7.26 ppm):  $\delta$  5.19 (d,  $J$  = 5.8 Hz, 1H, H-7), 5.01 – 5.00 (m, 1H, H-9), 4.96 – 4.95 (m, 1H, H-9'), 3.66 – 3.56 (m, 2H, H-3), 3.42 (s, 3H, OMe), 3.39 – 3.34 (m, 1H, H-6), 2.10 (s, 3H, OAc), 1.77 (app. t,  $J$  = 1.1 Hz, 3H, Me-8), 1.72 – 1.40 (m, 4H, H-4, H-5), 0.89 (s, 9H, TBS), 0.34 (s, 6H, TBS) ppm;

**<sup>13</sup>C-NMR** (400 MHz, CDCl<sub>3</sub>, CHCl<sub>3</sub> = 77.16 ppm):  $\delta$  170.3 (s, OAc), 141.3 (s, C-8), 114.2 (t, C-9), 82.2 (t, C-6), 78.4 (d, C-7), 63.1 (t, C-3), 58.9 (q, OMe), 28.8 (t, C-4), 27.1 (t, C-5), 26.1 (q, TBS), 21.3 (q, OAc), 19.4 (s, TBS), 18.5 (q, Me-8), – 5.2 (q, TBS) ppm;

$[\alpha]_D^{21} = - 5.5$  ( $c$  = 1.0, CHCl<sub>3</sub>);

**HRMS-ESI**  $m/z$  for C<sub>17</sub>H<sub>34</sub>O<sub>4</sub>SiNa [M+Na]<sup>+</sup> calc. 353.2124, found 353.2123.

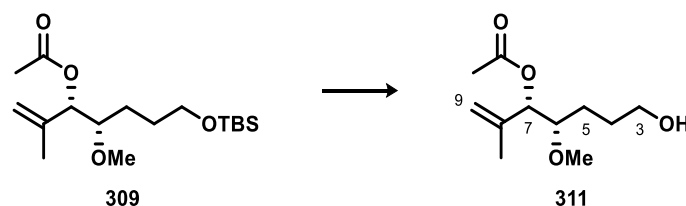
**(3*S*,4*S*)-7-Hydroxy-4-methoxy-2-methylhept-1-en-3-yl acetate (311)**

Silyl ether **309** (327 mg, 0.989 mmol, 1.0 eq.) was dissolved in THF (10 mL) and cooled to 0 °C. TBAF (1 M in THF, 1.40 mL, 1.39 mmol, 1.4 eq.) was added slowly. The reaction was stirred at this temperature for 40 min and 4 h at room temperature. The reaction was terminated by the addition of a saturated aqueous NH<sub>4</sub>Cl solution (10 mL). The phases were separated and the aqueous phase was extracted with EtOAc (3 x 15 mL). The combined organic phases were dried over MgSO<sub>4</sub>, filtered and the solvent was removed under reduced pressure. The crude product was purified by flash column chromatography (PE/EtOAc = 4:1 → 100% EtOAc) to yield alcohol **311** (181 mg, 0.836 mmol, 85%) as a colorless oil.

$R_f = 0.1$  (PE/EtOAc = 3:1);

<sup>1</sup>H-NMR (400 MHz, CDCl<sub>3</sub>, CHCl<sub>3</sub> = 7.26 ppm): δ 5.20 (d, *J* = 5.8 Hz, 1H, H-7), 4.99 (s, 1H, H-9), 4.94 (s, 1H, H-9'), 3.62 (t, *J* = 6.0 Hz, H-3), 3.43 (s, 3H, OMe), 3.37 – 3.33 (m, 1H, H-6), 2.08 (s, 3H, OAc), 2.00 (bs, 1H, OH), 1.75 (s, 3H, Me-8), 1.70 – 1.42 (m, 4H, H-4, H-5) ppm;

<sup>13</sup>C-NMR (400 MHz, CDCl<sub>3</sub>, CHCl<sub>3</sub> = 77.16 ppm): δ 170.2 (s, OAc), 141.1 (s, C-8), 114.4 (t, C-9), 81.3 (t, C-6), 78.1 (d, C-7), 62.8 (t, C-3), 58.9 (q, OMe), 28.8 (t, C-4), 27.2 (t, C-5), 21.3 (q, OAc), 19.3 (q, Me-8) ppm;

$[\alpha]_D^{23} = -4.6$  (*c* = 1.0, CHCl<sub>3</sub>);

HRMS-ESI *m/z* for C<sub>11</sub>H<sub>20</sub>O<sub>4</sub>Na [M+Na]<sup>+</sup> calc. 239.1260, found 239.1260.

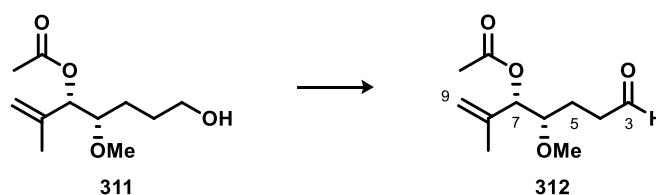
**(3*S*,4*S*)-4-Methoxy-2-methyl-7-oxohept-1-en-3-yl acetate (312)**

Oxalyl chloride (143 μL, 1.67 mmol, 2.0 eq.) was dissolved in CH<sub>2</sub>Cl<sub>2</sub> (3 mL) and cooled to –78 °C. DMSO (237 μL, 3.34 mmol, 4.0 eq.) was added slowly and the reaction was stirred for 15 min. Alcohol **311** (181 mg, 0.836 mmol, 1.0 eq.) was slowly added as a solution in CH<sub>2</sub>Cl<sub>2</sub> (2 mL) and stirring was continued for 1.5 h. Et<sub>3</sub>N (695 μL, 5.02 mmol, 6.0 eq.) was then added dropwise and the reaction was allowed to reach room temperature. The mixture was diluted with CH<sub>2</sub>Cl<sub>2</sub> (10 mL) and the reaction was terminated by the addition of a saturated aqueous NH<sub>4</sub>Cl solution (10 mL). The phases were separated and the aqueous phase was extracted with CH<sub>2</sub>Cl<sub>2</sub> (3 x 10 mL). The combined organic phases were washed with brine, dried over MgSO<sub>4</sub>, filtered and the solvent was removed under reduced pressure. The



crude product was purified by flash column chromatography (PE/EtOAc = 10:1) to yield aldehyde **312** (158 mg, 0.738 mmol, 88%) as a colorless oil.

$R_f$  = 0.2 (PE/EtOAc = 4:1);

$^1\text{H-NMR}$  (400 MHz,  $\text{CDCl}_3$ ,  $\text{CHCl}_3$  = 7.26 ppm):  $\delta$  9.75 (t,  $J$  = 1.6 Hz, 1H, CHO), 5.20 (d,  $J$  = 6.1 Hz, 1H, H-7), 5.03 – 5.02 (m, 1H, H-9), 4.99 – 4.98 (m, 1H, H-9'), 3.40 (s, 3H, OMe), 3.38 – 3.33 (m, 1H, H-6), 2.60 – 2.46 (m, 2H, H-4), 2.10 (s, 3H, OAc), 1.78 (app. t,  $J$  = 1.1 Hz, 3H, Me-8), 1.84 – 1.71 (m, 2H, H-5) ppm;

$^{13}\text{C-NMR}$  (400 MHz,  $\text{CDCl}_3$ ,  $\text{CHCl}_3$  = 77.16 ppm):  $\delta$  201.9 (d, C-3), 170.2 (s, OAc), 140.9 (s, C-8), 114.9 (t, C-9), 80.6 (t, C-6), 78.3 (d, C-7), 59.2 (q, OMe), 40.1 (t, C-4), 23.7 (t, C-5), 21.3 (q, OAc), 19.3 (q, Me-8) ppm.

### Ethyl (6*S*,7*S*,*E*)-7-acetoxy-6-methoxy-2,8-dimethylnona-2,8-dienoate (**313**)

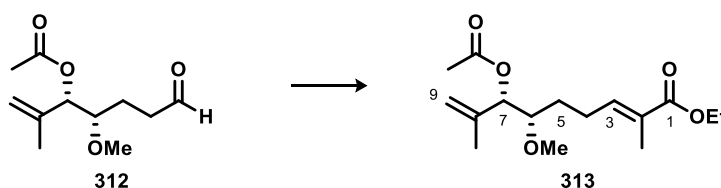

Aldehyde **312** (151 mg, 0.705 mmol, 1.0 eq.) was dissolved in  $\text{CHCl}_3$  (7 mL) in a sealed tube and ethyl 2-(triphenylphosphoranylidene)propionate (383 mg, 1.06 mmol, 1.5 eq.) was added. The tube was capped and the mixture was stirred overnight at 50 °C. The solvent was removed under reduced pressure to almost complete dryness. The residue was diluted with a minimal amount of  $\text{CH}_2\text{Cl}_2$  and was purified by flash column chromatography (PE/EtOAc = 4:1) to yield  $\alpha,\beta$ -unsaturated ester **313** (150 mg, 0.501 mmol, 71%) as a colorless oil.

$R_f$  = 0.4 (PE/EtOAc = 4:1);

$^1\text{H-NMR}$  (400 MHz,  $\text{CDCl}_3$ ,  $\text{CHCl}_3$  = 7.26 ppm):  $\delta$  6.72 (dq,  $J$  = 11.3, 1.4 Hz, 1H, H-3), 5.22 (d,  $J$  = 5.8 Hz, 1H, H-7), 5.02 – 5.01 (m, 1H, H-9), 4.98 – 4.96 (m, 1H, H-9'), 4.19 (q,  $J$  = 7.1 Hz, 2H,  $\text{OCH}_2\text{CH}_3$ ), 3.43 (s, 3H, OMe), 3.33 (q,  $J$  = 6.1 Hz, 1H, H-6), 2.33 – 2.22 (m, 2H, H-4), 2.10 (s, 3H, OAc), 1.84 (d,  $J$  = 1.2 Hz, 3H, Me-2), 1.77 (app. t,  $J$  = 1.1 Hz, 3H, Me-8), 1.59 – 1.54 (m, 2H, H-5), 1.29 (t,  $J$  = 7.1 Hz, 3H,  $\text{OCH}_2\text{CH}_3$ ) ppm;

$^{13}\text{C-NMR}$  (400 MHz,  $\text{CDCl}_3$ ,  $\text{CDCl}_3$  = 77.16 ppm):  $\delta$  170.2 (s, OAc), 168.3 (s, C-1), 141.3 (s, C-8), 141.1 (d, C-3), 128.5 (s, C-2), 114.5 (t, C-9), 80.8 (d, C-6), 78.1 (d, C-7), 60.6 (t,  $\text{OCH}_2\text{CH}_3$ ), 59.1 (q, OMe), 29.6 (t, C-5), 24.7 (t, C-4), 21.3 (q, OAc), 19.4 (q, Me-8), 14.4 (q,  $\text{OCH}_2\text{CH}_3$ ), 12.5 (q, Me-2) ppm;

$[\alpha]_D^{25}$  = -0.9 ( $c$  = 0.9,  $\text{CH}_2\text{Cl}_2$ );

**HRMS-ESI**  $m/z$  for  $\text{C}_{16}\text{H}_{26}\text{O}_5\text{Na}$   $[\text{M}+\text{Na}]^+$  calc. 321.1678, found 321.1677.

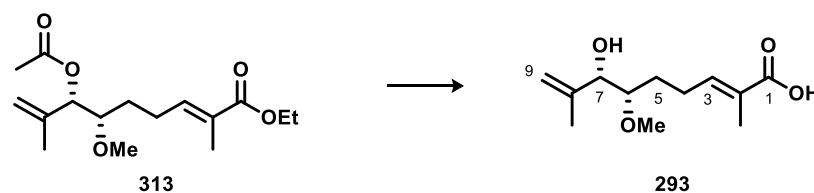
**(6*S*,7*S*,*E*)-7-Hydroxy-6-methoxy-2,8-dimethylnona-2,8-dienoic acid (293)**

Ester **313** (130 mg, 0.436 mmol, 1.0 eq.) was dissolved in THF/MeOH (1:1, 17.6 mL) and an aqueous LiOH solution (1.0 M, 4.40 mL, 10.0 eq.) was added. The mixture was heated to 40 °C and stirred overnight. Water (3 mL) was added and the solution was acidified with 1 M HCl to pH 2. The aqueous phase was extracted with EtOAc (3 x 10 mL). The combined organic phases were dried over MgSO<sub>4</sub>, filtered and the solvent was removed under reduced pressure. The crude product was purified by flash column chromatography (PE/EtOAc = 2:1, 1% AcOH) to yield acid **293** (72 mg, 0.315 mmol, 72%) as a pale yellow oil.

$R_f = 0.2$  (PE/EtOAc = 2:1 with 1% AcOH);

<sup>1</sup>H-NMR (400 MHz, CDCl<sub>3</sub>, CHCl<sub>3</sub> = 7.26 ppm):  $\delta$  6.88 (td,  $J = 7.5, 1.3$  Hz, 1H, H-3), 5.04 – 5.03 (m, 1H, H-9), 4.96 – 4.95 (m, 1H, H-9'), 3.88 (d,  $J = 1.3$  Hz, 1H, H-7), 3.44 (s, 3H, OMe), 3.28 – 3.24 (m, 1H, H-6), 2.27 (q,  $J = 7.8$  Hz, 2H, H-4), 1.83 (d,  $J = 1.2$  Hz, 3H, Me-2), 1.76 (t,  $J = 1.1$  Hz, 3H, Me-8), 1.74 – 1.58 (m, 2H, H-5) ppm;

<sup>13</sup>C-NMR (400 MHz, CDCl<sub>3</sub>):  $\delta$  173.2 (s, C-1), 144.3 (s, C-8), 144.3 (d, C-3), 127.6 (s, C-2), 114.1 (t, C-9), 81.7 (d, C-6), 77.3 (d, C-7), 58.4 (q, OMe), 28.9 (t, C-5), 24.4 (t, C-4), 18.0 (q, Me-8), 12.1 (q, Me-2) ppm;

$[\alpha]_D^{20} = +26.6$  ( $c = 1.0$ , CHCl<sub>3</sub>);

HRMS-ESI  $m/z$  for C<sub>12</sub>H<sub>20</sub>O<sub>4</sub>Na [M+Na]<sup>+</sup> calc. 251.1259, found 251.1255.

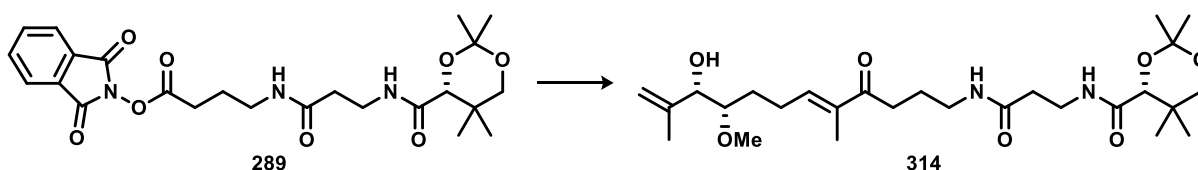
**(*R*)-*N*-(3-(((9*S*,10*S*,*E*)-10-Hydroxy-9-methoxy-5,11-dimethyl-4-oxododeca-5,11-dien-1-yl)amino)-3-oxopropyl)-2,2,5,5-tetramethyl-1,3-dioxane-4-carboxamide (314)**

Freshly prepared redox-active ester **289** (42 mg, 85.8  $\mu$ mol, 1.0 eq.) was dried under high vacuum for 15 min prior to use. Next, acid **293** (40 mg, 171.6  $\mu$ mol, 2.0 eq.), Ni(BPhen)Cl<sub>2</sub>·2DMF (8 mg, 17.0  $\mu$ mol, 0.2 eq.), Zn (dust, 26 mg, 257.4  $\mu$ mol, 3.0 eq.), benzoic anhydride (43 mg, 188.8  $\mu$ mol, 2.2 eq.), MgCl<sub>2</sub> (anhydrous, 12 mg, 128.7  $\mu$ mol, 1.5 eq.) and LiBr (7 mg, 85.8  $\mu$ mol, 1.0 mmol) were added to the flask and the atmosphere was changed by evacuating and backfilling with argon (3x). MeCN/THF (degassed by *fpt*, 3 cycles, 1:1.5, 1.70 mL) was added and the resulting dark red-brown mixture was stirred at room temperature for 14 h. The reaction mixture was diluted with EtOAc and washed with an aqueous 1 M HCl solution and an aqueous 1 M K<sub>2</sub>CO<sub>3</sub> solution and dried over MgSO<sub>4</sub>,

filtered through a plug of Celite<sup>®</sup> and the solvent was removed under reduced pressure. The crude reaction mixture was used in the next step without further analysis.

$R_f = 0.1$  (2% MeOH/CH<sub>2</sub>Cl<sub>2</sub>);

**HRMS-ESI**  $m/z$  for C<sub>27</sub>H<sub>46</sub>N<sub>2</sub>O<sub>7</sub>Na [M+Na]<sup>+</sup> calc. 533.3203, found 533.3105.

**(R)-2,4-Dihydroxy-N-(3-(((9S,10S,E)-10-hydroxy-9-methoxy-5,11-dimethyl-4-oxododeca-5,11-dien-1-yl)amino)-3-oxopropyl)-3,3-dimethylbutanamide (287)**

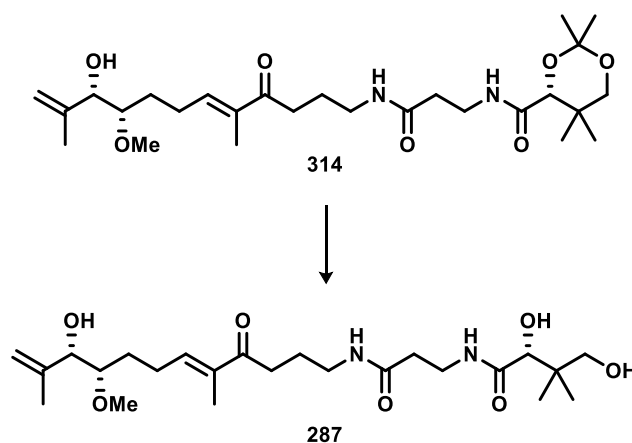

Crude acetone acetonide **314** (85.8  $\mu$ mol, 1.0 eq.) was dissolved in MeCN (2 mL), InCl<sub>3</sub> (57 mg, 257.4  $\mu$ mol, 3.0 eq.) was added, followed by water (6  $\mu$ L, 343.2  $\mu$ mol, 4.0 eq.) and stirring was continued at room temperature for 16 h. Water (3 mL) and CH<sub>2</sub>Cl<sub>2</sub> (5 mL) was added. The phases were separated and the aqueous phase was extracted with CH<sub>2</sub>Cl<sub>2</sub> (3 x 5 mL). The combined organic phases were dried over MgSO<sub>4</sub>, filtered and the solvent was removed under reduced pressure. The crude product was purified by flash column chromatography (CH<sub>2</sub>Cl<sub>2</sub>/MeOH = 20:1  $\rightarrow$  10:1) to yield “carba” pantetheine derivative **287** (0.3 mg, 6.0  $\mu$ mol, 0.7% o3s) as a colorless oil.

**HRMS-ESI**  $m/z$  for C<sub>24</sub>H<sub>42</sub>N<sub>2</sub>O<sub>7</sub>Na [M+Na]<sup>+</sup> calc. 493.5968, found 493.5970.

**(S)-4-Methoxy-5-((4-methoxybenzyl)oxy)pentan-1-ol (50)**

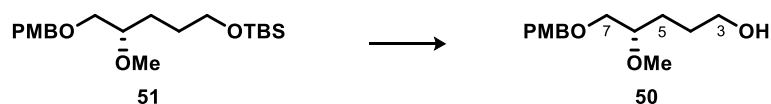

Silyl ether **51** (471 mg, 1.28 mmol, 1.0 eq.) was dissolved in THF (14 mL) and cooled to 0 °C. TBAF (1.0 M in THF, 1.40 mL, 1.41 mmol, 1.1 eq.) was added slowly and the reaction was allowed to reach room temperature. Stirring was continued for 1.5 h before the mixture was diluted with CH<sub>2</sub>Cl<sub>2</sub> and the reaction terminated by the addition of water. The phases were separated and the aqueous phase was extracted with CH<sub>2</sub>Cl<sub>2</sub> (3 x 10 mL). The combined organic phases were dried over MgSO<sub>4</sub>, filtered and the solvent was removed under reduced pressure. The crude product was purified by flash column chromatography (PE/EtOAc = 4:1  $\rightarrow$  100% EtOAc) to yield alcohol **50** (277 mg, 1.09 mmol, 85%, 89% brsm) as a colorless oil.

$R_f = 0.1$  (PE/EtOAc = 2:1);

**<sup>1</sup>H-NMR** (400 MHz, CDCl<sub>3</sub>, CHCl<sub>3</sub> = 7.26 ppm):  $\delta$  7.27 – 7.24 (m, 2H, PMB), 6.90 – 6.86 (m, 2H, PMB), 4.48 (s, 2H, PMB), 3.80 (s, 3H, PMB), 3.63 (t,  $J$  = 5.9 Hz, 2H, H-3), 3.51 – 3.43 (m, 2H, H-3), 3.42 (s, 3H, OMe), 3.39 – 3.36 (m, 1H, H-6), 1.96 (s, 1H, OH), 1.70 – 1.56 (m, 4H, H-4, H-5) ppm;

**<sup>13</sup>C-NMR** (400 MHz, CDCl<sub>3</sub>, CDCl<sub>3</sub> = 77.16 ppm):  $\delta$  159.3 (s, PMB), 130.4 (s, PMB), 129.4 (d, 2C, PMB), 113.9 (d, 2C, PMB), 80.2 (d, C-6), 73.2 (t, PMB), 71.6 (t, C-7), 63.0 (t, C-3), 57.7 (q, PMB), 55.4 (q, OMe), 28.8 (t, C-4), 28.5 (t, C-5) ppm;

$[\alpha]_D^{20} = -12.1$  ( $c$  = 1.0, CH<sub>2</sub>Cl<sub>2</sub>);

**HRMS-ESI**  $m/z$  for C<sub>14</sub>H<sub>22</sub>O<sub>4</sub>Na [M+Na]<sup>+</sup> calc. 277.1416, found 277.1420.

**(S)-4-Methoxy-5-((4-methoxybenzyl)oxy)pentanal (318)**

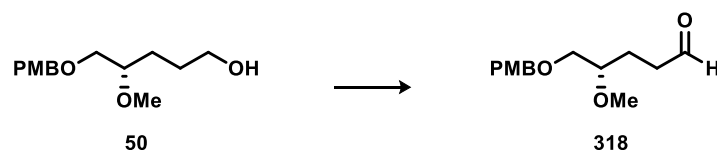

Alcohol **50** (68 mg, 0.270 mmol, 1.0 eq.) was dissolved in CH<sub>2</sub>Cl<sub>2</sub> (3 mL) and cooled to 0 °C. NaHCO<sub>3</sub> (34 mg, 0.405 mmol, 1.5 eq.) and DMP (169 mg, 0.405 mmol, 1.5 eq.) were added sequentially. Stirring was continued at this temperature for 10 minutes, before the reaction was allowed to reach room temperature and stirred for 1 h. The reaction was terminated by the addition of Na<sub>2</sub>S<sub>2</sub>O<sub>3</sub> (10w%) dissolved in saturated aqueous NaHCO<sub>3</sub> solution. The mixture was stirred vigorously until a clear solution emerged. The phases were separated and the aqueous phase was extracted with CH<sub>2</sub>Cl<sub>2</sub> (3 x 5 mL). The combined organic phases were washed with brine, dried over MgSO<sub>4</sub>, filtered and the solvent was removed under reduced pressure. The crude product was purified by flash column chromatography (PE/EtOAc = 4:1 → 2:1) to yield aldehyde **318** (62 mg, 0.251 mmol, 93%) as a colorless oil which was used in the next step without further analysis.

$R_f$  = 0.4 (PE/EtOAc = 2:1).

**(S)-1-Methoxy-4-(((2-methoxyhex-5-yn-1-yl)oxy)methyl)benzene (320)**

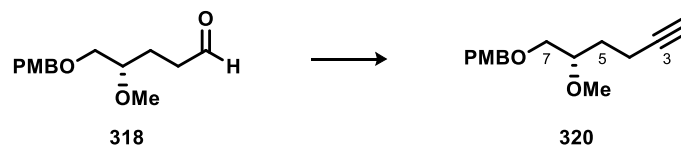

A solution of aldehyde **318** (154 mg, 0.606 mmol, 1.0 eq.) in MeOH (12 mL) was added dropwise to a solution of Ohira-Bestmann reagent **96** (175 mg, 0.909 mmol, 1.5 eq.) and K<sub>2</sub>CO<sub>3</sub> (188 mg, 1.36 mmol, 2.25 eq.) in MeOH (9 mL) at room temperature and stirred overnight. The reaction was terminated by the addition of a saturated aqueous NH<sub>4</sub>Cl solution. The phases were separated and the aqueous phase was extracted with MTBE (3 x 20 mL). The combined organic phases were washed with brine, dried over MgSO<sub>4</sub>, filtered and the solvent was removed under reduced pressure. The crude product was purified by flash column

chromatography (PE/EtOAc = 10:1 → 4:1) to yield alkyne **320** (99 mg, 0.397 mmol, 66%) as a colorless oil.

$R_f$  = 0.7 (PE/EtOAc = 2:1);

$^1\text{H-NMR}$  (400 MHz,  $\text{CDCl}_3$ ,  $\text{CHCl}_3$  = 7.26 ppm):  $\delta$  7.27 – 7.25 (m, 2H, PMB), 6.90 – 6.87 (m, 2H, PMB), 4.48 (s, 2H, PMB), 3.80 (s, 3H, PMB), 3.50 – 3.45 (m, 3H, H-6, H-7), 3.42 (s, 3H, OMe), 2.31 – 2.25 (m, 2H, H-4), 1.94 (t,  $J$  = 2.7 Hz, 1H, H-2), 1.76 – 1.71 (m, 2H, H-5) ppm;

$^{13}\text{C-NMR}$  (400 MHz,  $\text{CDCl}_3$ ,  $\text{CDCl}_3$  = 77.16 ppm):  $\delta$  159.3 (s, PMB), 130.5 (s, PMB), 129.4 (d, 2C, PMB), 113.9 (d, 2C, PMB), 84.3 (s, C-3), 78.6 (d, C-6), 73.2 (t, PMB), 71.3 (t, C-7), 68.6 (d, C-2), 58.0 (q, OMe), 55.4 (q, PMB), 30.7 (t, C-5), 27.1 (t, C-4) ppm;

$[\alpha]_D^{20}$  = –17.0 ( $c$  = 1.0,  $\text{CH}_2\text{Cl}_2$ );

**HRMS-ESI**  $m/z$  for  $\text{C}_{15}\text{H}_{20}\text{O}_3\text{Na}$   $[\text{M}+\text{Na}]^+$  calc. 271.1310, found 271.1315.

### (S)-1-Methoxy-4-(((2-methoxyhept-5-yn-1-yl)oxy)methyl)benzene (**321**)

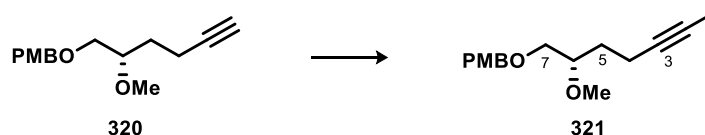

Alkyne **320** (79 mg, 0.318 mmol, 1.0 eq.) was dissolved in THF (3 mL) and cooled to  $-78\text{ }^\circ\text{C}$  followed by the addition of *n*-BuLi (2.5 M in hexane, 483  $\mu\text{L}$ , 1.21 mmol, 3.8 eq.). Stirring was continued for 1 h at this temperature before MeI (297  $\mu\text{L}$ , 4.77 mmol, 15.0 eq.) was added slowly. Stirring was continued for 20 min at  $-78\text{ }^\circ\text{C}$  and 30 min at  $0\text{ }^\circ\text{C}$  and 30 min at room temperature. The reaction was terminated by the addition of a saturated aqueous  $\text{NH}_4\text{Cl}$  solution. The phases were separated and the aqueous phase was extracted with MTBE (3 x 10 mL). The combined organic phases were dried over  $\text{MgSO}_4$ , filtered and the solvent was removed under reduced pressure. The crude product was purified by flash column chromatography (PE/EtOAc = 15:1 → 8:1) to yield alkyne **321** (73 mg, 0.280 mmol, 88%) as a colorless oil.

$R_f$  = 0.5 (PE/EtOAc = 4:1);

$^1\text{H-NMR}$  (400 MHz,  $\text{CDCl}_3$ ,  $\text{CHCl}_3$  = 7.26 ppm):  $\delta$  7.29 – 7.25 (m, 2H, PMB), 6.89 – 6.86 (m, 2H, PMB), 4.48 (s, 2H, PMB), 3.80 (s, 3H, PMB), 3.49 – 3.44 (m, 3H, H-6, H-7), 3.42 (s, 3H, OMe), 2.25 – 2.16 (m, 2H, H-4), 1.76 (t,  $J$  = 2.6 Hz, 3H, Me-2), 1.70 – 1.65 (m, 2H, H-5) ppm;

$^{13}\text{C-NMR}$  (400 MHz,  $\text{CDCl}_3$ ,  $\text{CDCl}_3$  = 77.16 ppm):  $\delta$  159.3 (s, PMB), 130.5 (s, PMB), 129.4 (d, 2C, PMB), 113.9 (d, 2C, PMB), 78.9 (s, C-3), 78.8 (t, C-7), 75.8 (s, C-2), 73.2 (t, PMB), 71.6 (d, C-6), 58.0 (q, OMe), 55.4 (q, PMB), 31.1 (t, C-5), 15.0 (t, C-4), 3.6 (q, Me-2) ppm;

$[\alpha]_D^{23}$  = –32.6 ( $c$  = 1.3,  $\text{CH}_2\text{Cl}_2$ );

**HRMS-ESI**  $m/z$  for  $\text{C}_{16}\text{H}_{22}\text{O}_3\text{Na}$   $[\text{M}+\text{Na}]^+$  calc. 285.1467, found 285.1469.

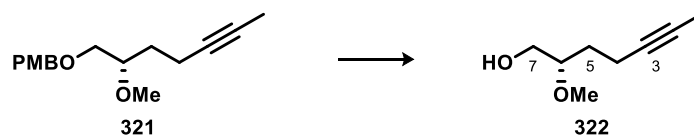
**(S)-2-Methoxyhept-5-yn-1-ol (322)**

PMB ether **321** (60 mg, 0.229 mmol, 1.0 eq.) was dissolved in MeCN/water (2 mL, 9:1) at room temperature. Ceric ammonium nitrate (275 mg, 0.503 mmol, 2.2 eq.) was added and stirring was continued for 2.5 h. CH<sub>2</sub>Cl<sub>2</sub> (5 mL) was added and the reaction was terminated by the addition of a saturated aqueous NaHCO<sub>3</sub> solution (5 mL). The phases were separated and the aqueous phase was extracted with CH<sub>2</sub>Cl<sub>2</sub> (3 x 10 mL). The combined organic phases were dried over MgSO<sub>4</sub>, filtered and the solvent was removed under reduced pressure. The crude product was purified by flash column chromatography (PE/EtOAc = 4:1 → 2:1) to yield alcohol **322** (29 mg, 0.205 mmol, 90%) as a colorless oil.

$R_f = 0.1$  (PE/EtOAc = 4:1);

<sup>1</sup>H-NMR (400 MHz, CDCl<sub>3</sub>, CHCl<sub>3</sub> = 7.26 ppm):  $\delta$  3.73 (dd,  $J = 11.5, 5.8$  Hz, 1H, H-7), 3.50 (dd,  $J = 11.6, 5.8$  Hz, 1H, H-7'), 3.44 – 3.39 (m, 1H, H-6), 3.42 (s, 3H, OMe), 2.24 – 2.13 (m, 2H, H-4), 1.93 (bs, 1H, OH), 1.79 – 1.71 (m, 1H, H-5), 1.77 ( $J = 2.6$  Hz, 3H, Me-2), 1.65 – 1.57 (m, 1H, H-5') ppm;

<sup>13</sup>C-NMR (400 MHz, CDCl<sub>3</sub>, CDCl<sub>3</sub> = 77.16 ppm):  $\delta$  80.3 (d, C-6), 78.5 (s, C-3), 76.2 (s, C-2), 63.7 (t, C-7), 57.5 (q, OMe), 29.9 (t, C-5), 14.9 (t, C-4), 3.6 (q, Me-2) ppm;

$[\alpha]_D^{25} = -10.1$  ( $c = 2.3$ , CHCl<sub>3</sub>);

HRMS-ESI  $m/z$  for C<sub>8</sub>H<sub>14</sub>O<sub>2</sub>Na [M+Na]<sup>+</sup> calc. 165.0891, found 165.0890.

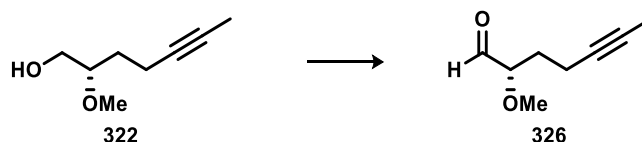
**(S)-2-Methoxyhept-5-ynal (326)**

DMSO (72  $\mu$ L, 1.01 mmol, 4.0 eq.) was added dropwise to a solution of oxalyl chloride (43  $\mu$ L, 0.506 mmol, 2.0 eq.) in CH<sub>2</sub>Cl<sub>2</sub> (1.0 mL) at  $-78$  °C. The resulting solution was stirred for 15 min, before alcohol **322** (36 mg, 0.253 mmol, 1.0 eq.) dissolved in CH<sub>2</sub>Cl<sub>2</sub> (1.5 mL) was added dropwise. Stirring was continued for 1 h at this temperature. Et<sub>3</sub>N (211  $\mu$ L, 1.52 mmol, 6.0 eq.) was added dropwise and after stirring for 30 min at  $-78$  °C the reaction was allowed to reach room temperature. The reaction was diluted with CH<sub>2</sub>Cl<sub>2</sub> (5 mL) and terminated by the addition of a saturated aqueous NH<sub>4</sub>Cl solution (10 mL). The phases were separated and the aqueous phase was extracted with CH<sub>2</sub>Cl<sub>2</sub> (3 x 5 mL). The combined organic phases were dried over MgSO<sub>4</sub>, filtered and the solvent was removed under reduced pressure.

The crude product was purified by flash column chromatography (PE/EtOAc = 4:1) to yield aldehyde **326** (27 mg, 0.193 mmol, 76%) as a colorless oil which was used in the next step without further analysis.

$R_f = 0.6$  (PE/EtOAc = 4:1).

**(3S,4S)-4-Methoxy-2-methylnon-1-en-7-yn-3-ol (323)**

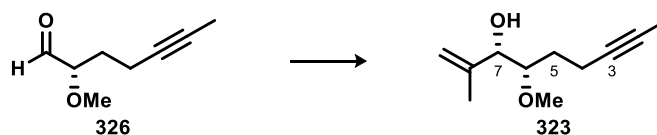

Aldehyde **326** (84 mg, 0.603 mmol, 1.0 eq.) was dissolved in THF (4 mL) and cooled to  $-78$  °C. Isopropenylmagnesium bromide (0.5 M in THF, 2.4 mL, 1.21 mmol, 2.0 eq.) was added dropwise via syringe pump (1.2 mL/min) and stirring was continued for 1 h. The reaction was diluted with MTBE (10 mL), terminated by the addition of a saturated aqueous  $\text{NaHCO}_3$  solution (5 mL) and allowed to reach room temperature. The phases were separated and the aqueous phase was extracted with MTBE (3 x 5 mL). The combined organic phases were dried over  $\text{MgSO}_4$ , filtered and the solvent was removed under reduced pressure. The crude product was purified by flash column chromatography (PE/EtOAc = 10:1  $\rightarrow$  4:1) to yield allylic alcohol **323** (32 mg, 0.230 mmol, 38%, *d.r.* = 6:1) as a colorless oil.

$R_f = 0.2$  (PE/EtOAc = 4:1);

$^1\text{H-NMR}$  (400 MHz,  $\text{CDCl}_3$ ,  $\text{CHCl}_3 = 7.26$  ppm):  $\delta$  5.02 (s, 1H, H-9), 4.93 (s, 1H, H-9'), 3.92 (d,  $J = 6.4$  Hz, 1H, H-7), 3.45 (s, 3H, OMe), 3.40 – 3.35 (m, 1H, H-6), 2.56 (bs, 1H, OH), 2.24 – 2.19 (m, 2H, H-4), 1.77 – 1.76 (m, 6H, Me-8, Me-2), 1.68 – 1.60 (m, 2H, H-5) ppm;

$[\alpha]_D^{20} = +5.0$  ( $c = 1.5$ ,  $\text{CHCl}_3$ );

**HRMS-ESI**  $m/z$  for  $\text{C}_{11}\text{H}_{18}\text{O}_2\text{Na}$   $[\text{M}+\text{Na}]^+$  calc. 205.1204, found 205.1200.

**(3S,4S)-4-Methoxy-2-methylnon-1-en-7-yn-3-ol (324)**

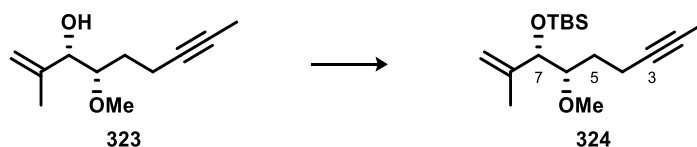

Allylic alcohol **323** (32 mg, 0.177 mmol, 1.0 eq.) was dissolved in  $\text{CH}_2\text{Cl}_2$  (2 mL) and cooled to  $0$  °C. 2,6-Lutidine (41  $\mu\text{L}$ , 0.353 mmol, 2.0 eq.) was added, followed by dropwise addition of TBSOTf (61  $\mu\text{L}$ , 0.265 mmol, 1.5 eq.). Stirring was continued at  $0$  °C for 1 h. The reaction was terminated by the addition of a saturated aqueous  $\text{NH}_4\text{Cl}$  solution (4 mL). The phases were separated and the aqueous phase was extracted with  $\text{CH}_2\text{Cl}_2$  (3 x 5 mL). The combined organic phases were washed with brine, dried over  $\text{MgSO}_4$ , filtered and the solvent was removed under reduced pressure. The crude product was purified by flash column chromatography (PE/EtOAc = 10:1  $\rightarrow$  6:1) to yield silyl ether **324** (26 mg, 0.088 mmol, 50%) as a colorless oil.

$R_f = 0.7$  (PE/EtOAc = 4:1);

$^1\text{H-NMR}$  (400 MHz,  $\text{CDCl}_3$ ,  $\text{CHCl}_3 = 7.26$  ppm):  $\delta$  4.88 (s, 1H, H-9), 4.83 (s, 1H, H-9'), 4.02 (d,  $J = 6.6$  Hz, 1H, H-7), 3.49 (s, 3H, OMe), 3.29 – 3.23 (m, 1H, H-6), 2.24 – 2.20 (m, 2H, H-

4), 1.77 (t,  $J = 2.5$  Hz, 3H, Me-2), 1.71 (s, 3H, Me-8), 1.61 – 1.52 (m, 1H, H-5), 1.41 – 1.39 (m, 1H, H-5'), 0.9 (s, 9H, TBS), 0.08 (s, 3H, TBS), 0.02 (s, 3H, TBS) ppm;

$^{13}\text{C-NMR}$  (400 MHz,  $\text{CDCl}_3$ ,  $\text{CDCl}_3 = 77.16$  ppm):  $\delta$  145.5 (s, C-8), 113.1 (t, C-9), 82.7 (d, C-6), 79.3 (d, C-7), 77.2 (s, C-3), 75.7 (s, C-2), 60.1 (q, OMe), 30.6 (t, C-5), 26.0 (q, 3C, TBS), 18.4 (s, TBS), 18.2 (q, Me-8), 15.3 (t, C-4), 3.6 (q, Me-2), -4.7 (q, TBS), -4.9 (q, TBS) ppm;

$[\alpha]_{\text{D}}^{20} = -19.7$  ( $c = 1.3$ ,  $\text{CHCl}_3$ );

**HRMS-ESI**  $m/z$  for  $\text{C}_{17}\text{H}_{32}\text{O}_2\text{SiNa}$   $[\text{M}+\text{Na}]^+$  calc. 319.2070, found 319.2071.

**(R)-N-(3-((4-Hydroxybutyl)amino)-3-oxopropyl)-2,2,5,5-tetramethyl-1,3-dioxane-4-carboxamide (317)**

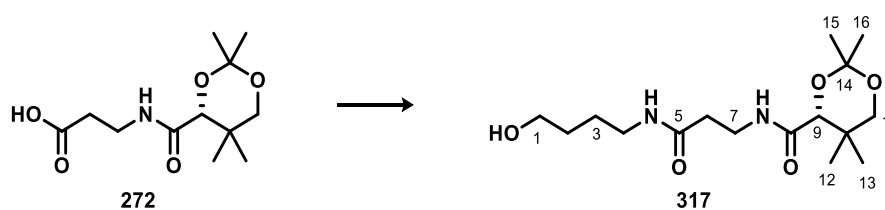

D-pantothenic dimethyl ketal **272** (184 mg, 0.710 mmol, 1.0 eq.) was dissolved in THF (7 mL) at room temperature and CDI (173 mg, 1.06 mmol, 1.5 eq.) was added. The mixture was stirred for 1.5 h before 4-amino-1-butanol (100  $\mu\text{L}$ , 1.06 mmol, 1.5 eq.) was added. The mixture was stirred for 48 h. The solvent was removed under reduced pressure and the resulting oil was dissolved in  $\text{CH}_2\text{Cl}_2$  and washed with a saturated aqueous  $\text{NH}_4\text{Cl}$  solution and brine. The phases were separated and the organic phase was dried over  $\text{MgSO}_4$ , filtered and the solvent was removed under reduced pressure. The crude product was purified by flash column chromatography (3%  $\text{MeOH}/\text{CH}_2\text{Cl}_2$ ) to yield alcohol **317** (77 mg, 0.233 mmol, 33%) as a colorless oil.

$R_f = 0.1$  (5%  $\text{MeOH}/\text{CH}_2\text{Cl}_2$ );

$^1\text{H-NMR}$  (400 MHz,  $\text{CDCl}_3$ ,  $\text{CHCl}_3 = 7.26$  ppm):  $\delta$  7.04 (bs, 1H, NH), 6.35 (bs, 1H, NH), 4.07 (s, 1H, H-9), 3.69 – 3.66 (m, 3H, H-1, H-11), 3.61 – 3.48 (m, 2H, H-7), 3.32 – 3.26 (m, 3H, H-4, H-11'), 2.44 (t,  $J = 6.2$  Hz, 2H, H-6), 1.61 – 1.59 (m, 4H, H-2, H-3), 1.46 (s, 3H, Me), 1.41 (s, 3H, Me), 1.03 (s, 3H, Me), 0.96 (s, 3H, Me) ppm;

$^{13}\text{C-NMR}$  (400 MHz,  $\text{CDCl}_3$ ,  $\text{CDCl}_3 = 77.16$  ppm):  $\delta$  171.1 (s, C-5), 170.5 (s, C-8), 99.3 (s, C-14), 77.3 (d, C-9), 71.6 (t, C-11), 62.5 (t, C-1), 39.4 (t, C-4), 36.5 (t, C-6), 35.1 (t, C-7), 33.1 (s, C-10), 29.9 (t, C-3), 29.6 (q, Me), 26.3 (t, C-2), 22.3 (q, Me), 19.0 (q, Me), 18.8 (q, Me) ppm;

$[\alpha]_{\text{D}}^{20} = +33.0$  ( $c = 0.7$ ,  $\text{CH}_2\text{Cl}_2$ );

**HRMS-ESI**  $m/z$  for  $\text{C}_{16}\text{H}_{30}\text{N}_2\text{O}_5\text{Na}$   $[\text{M}+\text{Na}]^+$  calc. 353.2052, found 353.2055.

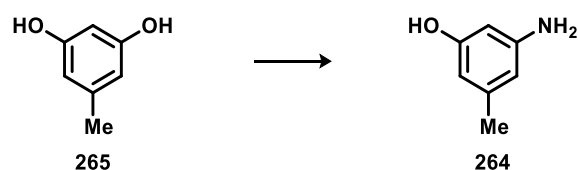

**3-Amino-5-methylphenol (264)**

5-Methylresorcinol (**265**, 960 mg, 7.74 mmol, 1.0 eq.) was dissolved in water (10 mL) and  $\text{NH}_4\text{Cl}$  (700 mg, 13.15 mmol, 1.7 eq.) and  $\text{NH}_3$  (28% aq., 4.00 mL) was added. The mixture was heated to 180 °C in an autoclave (model T304, Parr Instrument Company) and stirred for 18 h. The aqueous phase was extracted with EtOAc (5 x 20 mL) and the combined organic phases were washed with brine and dried over  $\text{MgSO}_4$ . The solvent was removed under reduced pressure. The crude product was purified by flash column chromatography (PE/EtOAc = 3:1) affording 3-amino-5-methylphenol (**264**, 496 mg, 4.02 mmol, 52%) as a brown solid.

The analytical data are consistent with those reported in the literature.<sup>[222]</sup>

**$^1\text{H-NMR}$**  (400 MHz,  $\text{DMSO-d}_6$ ,  $\text{DMSO} = 2.50$  ppm):  $\delta$  8.69 (s, 1H, OH), 5.83 – 5.82 (m, 1H,  $\text{H}_{\text{Ar}}$ ), 5.81 – 5.80 (m, 1H,  $\text{H}_{\text{Ar}}$ ), 5.76 – 5.75 (m, 1H,  $\text{H}_{\text{Ar}}$ ), 4.77 (s, 2H,  $\text{NH}_2$ ), 2.04 (s, 3H, Me) ppm;

**m.p.** 137 °C (lit. 138 °C)<sup>[222]</sup>.

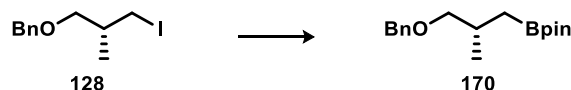
**5.7 Miscellaneous Reactions****(S)-2-(3-(Benzyloxy)-2-methylpropyl)-4,4,5,5-tetramethyl-1,3,2-dioxaborolane (170)**

According to the procedure published by Liu *et al.*<sup>[139]</sup>  $\text{CuI}$  (1.3 mg, 6.9  $\mu\text{mol}$ , 0.1 eq.),  $\text{LiOt-Bu}$  (13.9 mg, 137.9  $\mu\text{mol}$ , 2.0 eq.) and  $\text{B}_2\text{pin}_2$  (26.3 mg, 103.4  $\mu\text{mol}$ , 1.5 eq.) were placed in a schlenk finger and atmosphere was changed by evacuating and backfilling with argon (3x). THF (0.7 mL) was added followed by iodide **128** (20.0 mg, 68.9  $\mu\text{mol}$ , 1.0 eq.) as a solution in THF (0.4 mL). The mixture was stirred at room temperature for 22 h, diluted with EtOAc and filtered through a plug of silica gel, followed by washing with EtOAc. The solvent was removed under reduced pressure and the crude product was purified by flash column chromatography (PE/EtOAc = 30:1  $\rightarrow$  10:1) to yield pinacol boronic ester **170** (9.0 mg, 30.9  $\mu\text{mol}$ , 45%) as a colorless oil.

**$R_f$**  = 0.7 (PE/EtOAc = 8:1);

**$^1\text{H-NMR}$**  (400 MHz,  $\text{CDCl}_3$ ,  $\text{CHCl}_3 = 7.26$  ppm):  $\delta$  7.34 – 7.29 (m, 5H, Bn), 4.50 (s, 2H, Bn), 3.24 (d,  $J = 6.7$  Hz, 2H, H-3), 2.08 – 2.01 (m, 1H, H-2), 1.22 (s, 12H, Bpin), 0.95 (d,  $J = 6.7$  Hz, 3H, Me-2), 0.88 (dd,  $J = 15.5, 6.3$  Hz, 1H, H-1), 0.66 (dd,  $J = 15.5, 7.9$  Hz, 1H, H-1')

**HRMS-ESI**  $m/z$  for  $\text{C}_{17}\text{H}_{27}\text{BO}_3\text{Na}$  [ $\text{M}+\text{Na}$ ]<sup>+</sup> calc. 313.1998, found 313.1995.

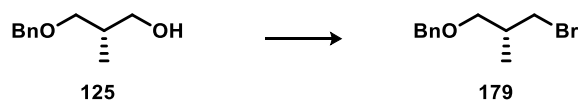
**(R)-((3-Bromo-2-methylpropoxy)methyl)benzene (179)**

Alcohol **125** (111 mg, 0.616 mmol, 1.0 eq.) was dissolved in CH<sub>2</sub>Cl<sub>2</sub> (1.5 mL). PPh<sub>3</sub> (162 mg, 0.616 mmol, 1.0 eq.) was added followed by a solution of NBS (111 mg, 0.622 mmol, 1.01 eq.) in CH<sub>2</sub>Cl<sub>2</sub> (2.5 mL). The reaction was cooled with a water bath and stirred overnight at room temperature. The reaction was terminated by the addition of water. The phases were separated and the aqueous phase was extracted with CH<sub>2</sub>Cl<sub>2</sub> (3 x 10 mL). The combined organic phases were dried over MgSO<sub>4</sub>, filtered and the solvent was removed under reduced pressure. The crude product was purified by flash column chromatography (PE/EtOAc = 10:1 → 5:1) to yield bromide **179** (115 mg, 0.471 mmol, 76%, 87% brsm) as a colorless oil.

The analytical data are consistent with those reported in the literature.<sup>[223,224]</sup>

$R_f$  = 0.6 (PE/EtOAc = 4:1);

<sup>1</sup>H-NMR (400 MHz, CDCl<sub>3</sub>, CHCl<sub>3</sub> = 7.26 ppm):  $\delta$  7.51 – 7.12 (m, 5H, Bn), 4.52 (s, Bn), 3.53 – 3.48 (m, 2H, H-1, H-3), 3.45 – 3.38 (m, 2H, H-1', H-3'), 2.18 – 2.10 (m, 1H, H-2), 1.04 (d,  $J$  = 6.8 Hz, 3H, Me-2) ppm;

$[\alpha]_D^{21}$  = –15.1 ( $c$  = 1.0, CH<sub>2</sub>Cl<sub>2</sub>; lit.  $[\alpha]_D^{20}$  = –8.9,  $c$  = 5.0, MeOH)<sup>[224]</sup>;

HRMS-ESI  $m/z$  not found.

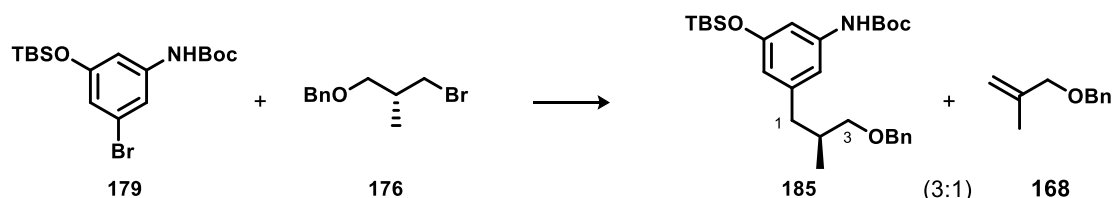
***tert*-Butyl (*S*)-(3-(3-(benzyloxy)-2-methylpropyl)-5-((*tert*-butyldimethylsilyl)oxy)phenyl)carbamate (185)**

A flame-dried Schlenk finger was charged with aryl bromide **176** (46 mg, 115.0  $\mu$ mol, 1.0 eq.), activated zinc dust<sup>22</sup> (15 mg, 230.0  $\mu$ mol, 2.0 eq.), NaI (4.3 mg, 29.0  $\mu$ mol, 0.25 eq.) and 2,2'-bipyridyl (2.0 mg, 11.5  $\mu$ mol, 0.1 eq.) under an argon stream. The reaction vessel was transferred to a glovebox and Ni(cod)<sub>2</sub> (6.5 mg, 23.0  $\mu$ mol, 0.2 eq.) was added. The Schlenk finger was capped with a rubber septum. Alkyl bromide **179** (34 mg, 138.0  $\mu$ mol, 1.2 eq.) was dissolved in DMPU (770  $\mu$ L) and pyridine (1  $\mu$ L) and the mixture was added to the reaction vessel. The mixture was stirred at 60 °C for 6 days before it was cooled to room temperature and diluted with EtOAc (20 mL) and filtered through Celite<sup>®</sup>. The filtrate was washed with an aqueous 9.2 M NaHSO<sub>4</sub> solution and water. The phases were separated and the aqueous phase was extracted with EtOAc (3 x 10 mL). The combined organic phases were

<sup>22</sup> Commercial zinc dust (400 mg) was treated with aq. HCl (0.5 M, 4 mL) for 1 min, then washed with water (4 x 2 mL), anhydrous EtOH (4 x 2 mL), and Et<sub>2</sub>O (4 x 2 mL), and dried under vacuum. The obtained activated zinc dust was stored under argon.

dried over  $\text{MgSO}_4$ , filtered and the solvent was removed under reduced pressure. The crude product was purified by flash column chromatography (PE/EtOAc = 10:1  $\rightarrow$  2:1) to yield compound **185** (10.5 mg, 21.6  $\mu\text{mol}$ , 19%) as a 3:1-mixture with the elimination product **168** colorless oil.

$R_f$  = 0.5 (PE/EtOAc = 4:1);

$^1\text{H-NMR}$  (400 MHz,  $\text{CDCl}_3$ ,  $\text{CHCl}_3$  = 7.26 ppm):  $\delta$  7.35 – 7.34 (m, 5H, Bn), 6.74 (t,  $J$  = 2.1 Hz, 1H,  $\text{H}_{\text{Ar}}$ ), 6.72 (s, 1H,  $\text{H}_{\text{Ar}}$ ), 6.33 – 6.32 (m, 2H,  $\text{H}_{\text{Ar}}$ , NH), 4.50 (s, 2H, Bn), 3.36 – 3.26 (m, 2H, H-3), 2.69 (dd,  $J$  = 13.3, 6.1 Hz, 1H, H-1), 2.31 (dd,  $J$  = 13.3, 8.1 Hz, 1H, H-1'), 2.07 – 2.00 (m, 1H, H-2), 1.51 (s, 9H, Boc), 0.97 (s, 9H, TBS), 0.90 (d,  $J$  = 6.7 Hz, 3H, Me-2), 0.18 (s, 6H, TBS) ppm;

$^{13}\text{C-NMR}$  (400 MHz,  $\text{CDCl}_3$ ,  $\text{CDCl}_3$  = 77.16 ppm):  $\delta$  156.1 (s,  $\text{C}_{\text{Ar}}$ ), 151.4 (s,  $\text{C}_{\text{Ar}}$ ), 142.8 (s, Boc), 139.2 (s,  $\text{C}_{\text{Ar}}$ ), 138.9 (s, Bn), 128.5 (d, 2C, Bn), 127.8 (d, 2C, Bn), 127.6 (d, Bn), 115.8 (d,  $\text{C}_{\text{Ar}}$ ), 112.5 (d,  $\text{C}_{\text{Ar}}$ ), 108.1 (d,  $\text{C}_{\text{Ar}}$ ), 80.5 (s, Boc), 75.1 (t, C-3), 73.1 (t, Bn), 40.1 (t, C-1), 35.5 (d, C-2), 28.5 (q, 3C, Boc), 25.8 (q, 3C, TBS), 18.3 (s, TBS), 17.0 (q, Me-2), -4.2 (q, 2C, TBS) ppm;

**GCMS**  $m/z$  for  $\text{C}_{28}\text{H}_{43}\text{NO}_4\text{Si}$  [ $M$ =485.2961]: 485.3 (M), 384.1 ( $\text{M}-\text{C}_5\text{H}_9\text{O}_2^+$  (Boc)), 293.4 ( $\text{M}-\text{C}_{12}\text{H}_{16}\text{O}_2^+$  (Boc, Bn)), 238.2 ( $\text{M}-\text{C}_{16}\text{H}_{25}\text{O}_2^+$  (Boc, Bn, *t*-Bu)).

### (S)-1-(3-(Benzyloxy)-2-methylpropyl)-3-methoxybenzene (**167**)

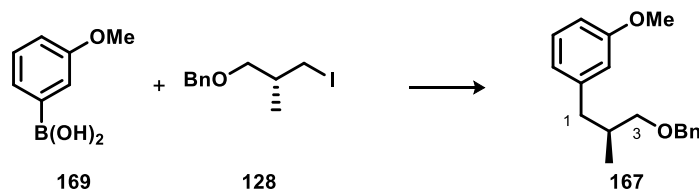

3-Methoxyphenylboronic acid (**169**, 31 mg, 207  $\mu\text{mol}$ , 1.2 eq.),  $\text{Ni}(\text{cod})_2$  (1.9 mg, 6.9  $\mu\text{mol}$ , 4 mol%), bathophenanthroline (4.7 mg, 13.8  $\mu\text{mol}$ , 8 mol%) and  $\text{KO}t\text{-Bu}$  (31 mg, 276  $\mu\text{mol}$ , 1.6 eq.) were placed in a microwave vial, sealed and the atmosphere was exchanged with argon (3x). *s*-BuOH (1 mL) was added through the septum and the mixture was stirred for 10 min at room temperature. Iodide **128** (50 mg, 172  $\mu\text{mol}$ , 1.0 eq.) as a solution in *s*-BuOH (0.7 mL) was added and the mixture was stirred under microwave-irradiation at 120 °C for 20 min. The crude reaction mixture was filtered through a silica plug, rinsed with MTBE and the solvent was removed under reduced pressure. The crude product was purified by flash column chromatography (PE/EtOAc = 20:1) to yield compound **167** (5.5 mg, 20.0  $\mu\text{mol}$ , 12%) as a colorless oil.

$R_f$  = 0.6 (PE/EtOAc = 6:1);

$^1\text{H-NMR}$  (400 MHz,  $\text{CDCl}_3$ ,  $\text{CHCl}_3$  = 7.26 ppm):  $\delta$  7.36 – 7.34 (m, 4H, Bn), 7.30 – 7.26 (m, 1H,  $\text{H}_{\text{Ar}}$ ), 7.20 – 7.16 (m, 1H,  $\text{H}_{\text{Ar}}$ ), 6.76 – 6.72 (m, 3H,  $\text{H}_{\text{Ar}}$ ), 4.51 (s, 2H, Bn), 3.79 (s, 3H, OMe), 3.34 – 3.31 (m, 2H, H-3), 2.80 (dd,  $J$  = 13.3, 5.9 Hz, 1H, H-1), 2.39 (dd,  $J$  = 13.3, 8.3 Hz, 1H, H-1'), 2.11 – 2.06 (m, 1H, H-2), 0.92 (d,  $J$  = 6.7 Hz, 3H, Me-2) ppm;

**GCMS**  $m/z$  for  $\text{C}_{18}\text{H}_{22}\text{O}_2$  [ $M$ =270.1620]: 270.1 (M), 255.1 ( $\text{M}-\text{CH}_3^+$ ), 163.1 ( $\text{M}-\text{C}_7\text{H}_7\text{O}^+$  (OBn)).

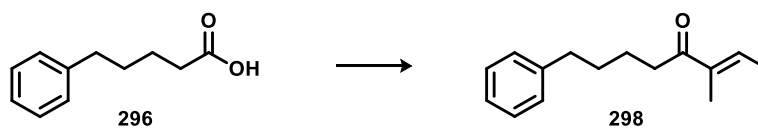
**(E)-3-Methyl-8-phenyloct-2-en-4-one (298)**

A flask was charged with 5-phenylvaleric acid (**296**, 39 mg, 0.216 mmol, 1.0 eq.) and *N*-hydroxyphthalimide (37 mg, 0.227 mmol, 1.05 eq.). The atmosphere was changed by evacuating and backfilling with argon (3x). CH<sub>2</sub>Cl<sub>2</sub> (1.4 mL) was added and the mixture was stirred vigorously. Then DIC (37 μL, 0.238 mmol, 1.1 eq.) was added dropwise via syringe and stirring was continued at room temperature 2 h. Consumption of the starting material was monitored by LCMS and TLC. The solvent was removed under reduced pressure and the redox-active ester was directly used in the next step without further purification.

The freshly prepared redox-active ester was dried under high vacuum for 15 min prior to use. Next, (*E*)-2-methylbut-2-enoic acid (43 mg, 0.433 mmol, 2.0 eq.), Ni(BPhen)Cl<sub>2</sub>·2DMF (20 mg, 0.043 mmol, 0.2 eq.), Zn (dust, 42 mg, 0.649 mmol, 3.0 eq.), benzoic anhydride (108 mg, 0.476 mmol, 2.2 eq.), MgCl<sub>2</sub> (anhydrous, 31 mg, 0.324 mmol, 1.5 eq.) and LiBr (19 mg, 0.216 mmol, 1.0 mmol) were added to the flask and the atmosphere was changed by evacuating and backfilling with argon (3x). MeCN/THF (degassed by *fpt*, 3 cycles, 1:1.5, 1 mL) was added and the resulting dark red-brown mixture was stirred at room temperature for 14 h. The reaction mixture was diluted with EtOAc and washed with an aqueous 1 M HCl solution and an aqueous 1 M K<sub>2</sub>CO<sub>3</sub> solution and dried over MgSO<sub>4</sub>, filtered and the solvent was removed under reduced pressure. The crude product was purified by flash column chromatography (PE/EtOAc = 10:1) to yield ketone **298** (30 mg, 0.137 mmol, 64% o2s) as a colorless oil.

**R<sub>f</sub>** = 0.6 (PE/EtOAc = 6:1);

**<sup>1</sup>H-NMR** (400 MHz, CDCl<sub>3</sub>, CHCl<sub>3</sub> = 7.26 ppm): δ 7.18 – 7.15 (m, 5H, H<sub>Ar</sub>), 6.74 – 6.69 (m, 1H, H-2), 2.67 – 2.61 (m, 4H, H-5/H-8), 1.84 (d, *J* = 7.0 Hz, 3H, H-1), 1.77 (s, 3H, Me-2), 1.67 – 1.58 (m, 4H, H-6/H-7) ppm;

**<sup>13</sup>C-NMR** (400 MHz, CDCl<sub>3</sub>, CDCl<sub>3</sub> = 77.16 ppm): δ 202.0 (s, C-4), 142.5 (s, C<sub>Ar</sub>), 138.5 (s, C-3), 137.1 (d, C-2), 128.5 (d, 2C, C<sub>Ar</sub>), 128.4 (d, 2C, C<sub>Ar</sub>), 125.8 (d, C<sub>Ar</sub>), 37.1 (t, C-8), 36.0 (t, C-5), 31.4 (t, C-7), 24.8 (t, C-6), 14.9 (q, Me-2), 11.2 (q, C-1) ppm;

**HRMS-ESI** *m/z* for C<sub>15</sub>H<sub>20</sub>ONa [M+Na]<sup>+</sup> calc. 239.1412, found 239.1410.

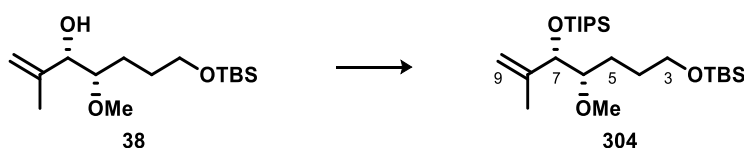
**(8*S*,9*S*)-11,11-Diisopropyl-8-methoxy-2,2,3,3,12-pentamethyl-9-(prop-1-en-2-yl)-4,10-dioxa-3,11-disilatridecane (304)**

Allylic alcohol **38** (196 mg, 0.679 mmol, 1.0 eq.) was dissolved in CH<sub>2</sub>Cl<sub>2</sub> (6 mL) and cooled to 0 °C. 2,6-Lutidine (365 μL, 1.36 mmol, 2.0 eq.) and TIPSOTf (235 μL, 2.04 mmol, 3.0 eq.) were sequentially added and the reaction was allowed to reach room temperature. Stirring was

continued for 18 h before the reaction was terminated by the addition of a saturated aqueous  $\text{NH}_4\text{Cl}$  solution. The phases were separated and the aqueous phase was extracted with  $\text{CH}_2\text{Cl}_2$  (3 x 10 mL). The combined organic phases were washed with brine, dried over  $\text{MgSO}_4$ , filtered and the solvent was removed under reduced pressure. The crude product was purified by flash column chromatography (PE/EtOAc = 15:1) to yield bis-silyl ether **304** (275 mg, 0.619 mmol, 91%) as a colorless oil which was of sufficient purity to be used in the next step.

$R_f$  = 0.8 (PE/EtOAc = 4:1);

$^1\text{H-NMR}$  (400 MHz,  $\text{CDCl}_3$ ,  $\text{CHCl}_3$  = 7.26 ppm):  $\delta$  4.93 (s, 1H, 9), 4.87 (s, 1H, 9'), 4.26 (d,  $J$  = 5.9 Hz, 1H, H-7), 3.65 – 3.55 (m, 2H, H-3), 3.45 (s, 3H, OMe), 3.18 – 3.14 (m, 1H, H-6), 1.73 (s, 3H, Me-8), 1.69 – 1.43 (m, 4H, H-4, H-5), 1.06 (m, 21H, TIPS), 0.88 (s, 9H, TBS), 0.03 (s, 6H, TBS) ppm;

$^{13}\text{C-NMR}$  (400 MHz,  $\text{CDCl}_3$ ,  $\text{CHCl}_3$  = 77.16 ppm):  $\delta$  145.4 (s, C-8), 113.0 (t, C-9), 84.9 (t, C-6), 78.5 (d, C-7), 63.6 (t, C-3), 59.0 (q, OMe), 29.5 (t, C-4), 26.8 (t, C-5), 26.1 (q, 3C, TBS), 19.0 (q, Me-8), 18.5 (s, TBS), 18.3 (q, 3C, TIPS), 18.2 (q, 3C, TIPS), 12.6 (d, 3C, TIPS) – 5.1 (q, 2C, TBS) ppm;

$[\alpha]_D^{21}$  = –9.8 ( $c$  = 1.0,  $\text{CH}_2\text{Cl}_2$ );

**HRMS-ESI**  $m/z$  for  $\text{C}_{24}\text{H}_{52}\text{O}_3\text{Si}_2\text{Na}$   $[\text{M}+\text{Na}]^+$  calc. 467.3353, found 467.3352.

#### (4*S*,5*S*)-4-Methoxy-6-methyl-5-((triisopropylsilyl)oxy)hept-6-en-1-ol (**305**)

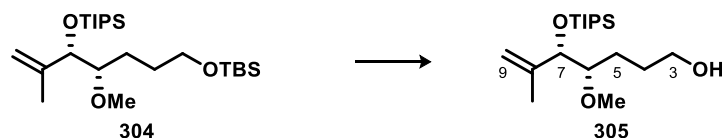

Bis-silyl ether **304** (114 mg, 0.256 mmol, 1.0 eq.) was dissolved in EtOH/ $\text{H}_2\text{O}$  (3 mL, 9:1) and PPTS (32 mg, 0.128 mmol, 0.5 eq.) was added. Stirring was continued at room temperature for 18 h. The mixture was diluted with  $\text{CH}_2\text{Cl}_2$  and the reaction was terminated by the addition of a saturated aqueous  $\text{NaHCO}_3$  solution. The phases were separated and the aqueous phase was extracted with  $\text{CH}_2\text{Cl}_2$  (3 x 15 mL). The combined organic phases were washed with brine, dried over  $\text{MgSO}_4$ , filtered and the solvent was removed under reduced pressure. The crude product was purified by flash column chromatography (PE/EtOAc = 8:1) to yield primary alcohol **305** (45 mg, 0.135 mmol, 53%) as a colorless oil.

$R_f$  = 0.3 (PE/EtOAc = 4:1);

$^1\text{H-NMR}$  (400 MHz,  $\text{CDCl}_3$ ,  $\text{CHCl}_3$  = 7.26 ppm):  $\delta$  4.95 (s, 1H, 9), 4.89 (s, 1H, 9'), 4.32 (d,  $J$  = 6.0 Hz, 1H, H-7), 3.62 (t,  $J$  = 6.0 Hz, 2H, H-3), 3.47 (s, 3H, OMe), 3.22 – 3.19 (m, 1H, H-6), 1.90 (bs, 1H, OH), 1.74 (s, 3H, Me-8), 1.70 – 1.64 (m, 2H, H-4), 1.31 – 1.20 (m, 2H, H-5), 1.06 (m, 21H, TIPS) ppm;

$^{13}\text{C-NMR}$  (400 MHz,  $\text{CDCl}_3$ ,  $\text{CHCl}_3$  = 77.16 ppm):  $\delta$  145.1 (s, C-8), 113.2 (t, C-9), 85.0 (t, C-6), 76.8 (d, C-7), 63.2 (t, C-3), 58.8 (q, OMe), 29.5 (t, C-4), 26.7 (t, C-5), 19.1 (q, Me-8), 18.2 (q, 3C, TIPS), 18.2 (q, 3C, TIPS), 12.6 (d, 3C, TIPS) ppm;

$[\alpha]_D^{23}$  = –4.1 ( $c$  = 1.1,  $\text{CHCl}_3$ );

**HRMS-ESI**  $m/z$  for  $\text{C}_{18}\text{H}_{38}\text{O}_3\text{Si}_2\text{Na}$   $[\text{M}+\text{Na}]^+$  calc. 353.2488, found 353.2489.

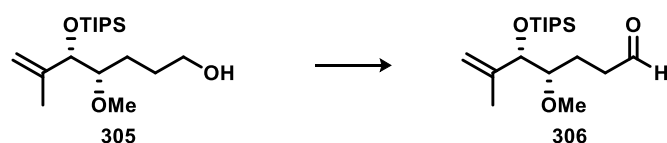
**(4*S*,5*S*)-4-Methoxy-6-methyl-5-((triisopropylsilyl)oxy)hept-6-enal (306)**

Oxalyl chloride (23  $\mu\text{L}$ , 0.270 mmol, 2.0 eq.) was dissolved in  $\text{CH}_2\text{Cl}_2$  (0.5 mL) in a sealed tube and cooled to  $-78\text{ }^\circ\text{C}$ . DMSO (38  $\mu\text{L}$ , 0.541 mmol, 4.0 eq.) was added slowly and the reaction was stirred for 15 min. Alcohol **305** (45 mg, 0.135 mmol, 1.0 eq.) was added as a solution in  $\text{CH}_2\text{Cl}_2$  (0.5 mL) and stirring was continued for 40 min.  $\text{Et}_3\text{N}$  (112  $\mu\text{L}$ , 0.811 mmol, 6.0 eq.) was added slowly and the reaction was allowed to reach room temperature. The mixture was diluted with  $\text{CH}_2\text{Cl}_2$  and the reaction was terminated by the addition of a saturated aqueous  $\text{NH}_4\text{Cl}$  solution. The phases were separated and the aqueous phase was extracted with  $\text{CH}_2\text{Cl}_2$  (3 x 5 mL). The combined organic phases were washed with brine, dried over  $\text{MgSO}_4$ , filtered and the solvent was removed under reduced pressure. Crude aldehyde **306** was used in the next step without further purification.

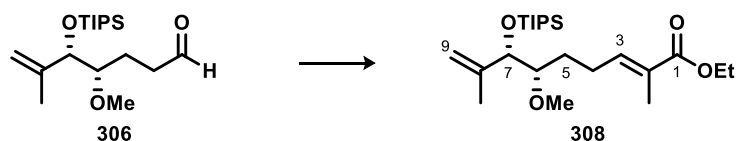
**Ethyl (6*S*,7*S*,*E*)-6-methoxy-2,8-dimethyl-7-((triisopropylsilyl)oxy)nona-2,8-dienoate (308)**

Aldehyde **306** (46 mg, 0.139 mmol, 1.0 eq.) was dissolved in  $\text{CHCl}_3$  (1.5 mL) in a sealed tube and ethyl 2-(triphenylphosphoranylidene)propionate (**307**, 76 mg, 0.209 mmol, 1.5 eq.) was added. The tube was capped and the mixture was stirred overnight at  $50\text{ }^\circ\text{C}$ . The solvent was removed under reduced pressure to almost complete dryness. The residue was diluted with a minimal amount of  $\text{CH}_2\text{Cl}_2$  and was purified by flash column chromatography (PE/EtOAc = 6:1) to yield  $\alpha,\beta$ -unsaturated ester **308** (44 mg, 0.106 mmol, 76% o2s) as a colorless oil.

$R_f = 0.7$  (PE/EtOAc = 4:1);

$^1\text{H-NMR}$  (400 MHz,  $\text{CDCl}_3$ ,  $\text{CHCl}_3 = 7.26$  ppm):  $\delta$  6.76 – 6.72 (m, 1H, H-3), 4.96 – 4.95 (m, 1H, H-9), 4.90 – 4.89 (m, 1H, H-9'), 4.32 (d,  $J = 5.7$  Hz, 1H, H-7), 4.18 (q,  $J = 7.1$  Hz, 2H,  $\text{OCH}_2\text{CH}_3$ ), 3.45 (s, 3H, OMe), 3.17 (ddd,  $J = 9.1, 5.8, 2.8$  Hz, 1H, H-6), 2.32 – 2.22 (m, 2H, H-4), 1.83 (d,  $J = 1.1$  Hz, 3H, Me-2), 1.74 (s, 3H, Me-8), 1.68 – 1.61 (m, 1H, H-5), 1.41 – 1.33 (m, 1H, H-5'), 1.29 (t,  $J = 7.1$  Hz, 3H,  $\text{OCH}_2\text{CH}_3$ ), 1.09 – 1.04 (m, 21H, TIPS) ppm;

**HRMS-ESI**  $m/z$  for  $\text{C}_{23}\text{H}_{44}\text{O}_4\text{SiNa}$  [ $\text{M}+\text{Na}$ ] $^+$  calc. 435.2907, found 435.2909.

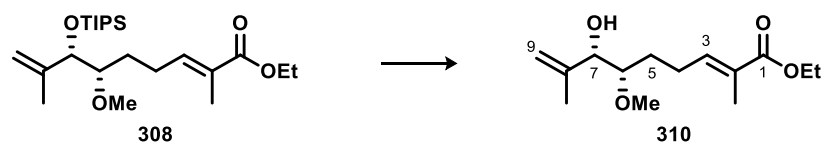
**Ethyl (6*S*,7*S*,*E*)-7-hydroxy-6-methoxy-2,8-dimethylnona-2,8-dienoate (310)**

Silyl ether **308** (44 mg, 0.106 mmol, 1.0 eq.) was dissolved in THF (2 mL) was cooled to 0 °C. TBAF (1 M in THF, 137  $\mu$ L, 0.137 mmol, 1.3 eq.) was added slowly and stirring was continued for 4 h. The reaction was terminated by the addition of a saturated aqueous  $\text{NH}_4\text{Cl}$  solution. The phases were separated and the aqueous phase was extracted with EtOAc (3 x 10 mL). The combined organic phases were washed with brine, dried over  $\text{MgSO}_4$ , filtered and the solvent was removed under reduced pressure. The crude product was purified by flash column chromatography (PE/EtOAc = 8:1  $\rightarrow$  5:1) to yield alcohol **310** (22 mg, 0.084 mmol, 79%) as a colorless oil.

$R_f$  = 0.4 (PE/EtOAc = 4:1);

$^1\text{H-NMR}$  (400 MHz,  $\text{CDCl}_3$ ,  $\text{CHCl}_3$  = 7.26 ppm):  $\delta$  6.72 (dt,  $J$  = 7.4, 1.1 Hz, 1H, H-3), 5.03 (s, 1H, H-9), 4.95 (s, 1H, H-9'), 4.18 (q,  $J$  = 7.1 Hz, 2H,  $\text{OCH}_2\text{CH}_3$ ), 3.96 (d,  $J$  = 6.7 Hz, 1H, H-7), 3.43 (s, 3H, OMe), 3.27 – 3.22 (m, 1H, H-6), 2.30 (bs, 1H, OH), 2.27 – 2.22 (m, 2H, H-4), 1.83 (s, 3H, Me-2), 1.75 (s, 3H, Me-8), 1.71 – 1.55 (m, 2H, H-5), 1.28 (t,  $J$  = 7.1 Hz, 3H,  $\text{OCH}_2\text{CH}_3$ ) ppm;

$^{13}\text{C-NMR}$  (400 MHz,  $\text{CDCl}_3$ ,  $\text{CHCl}_3$  = 77.16 ppm):  $\delta$  168.3 (s, C-1), 144.4 (s, C-8), 141.5 (d, C-3), 128.4 (s, C-2), 114.2 (t, C-9), 81.7 (d, C-6), 77.4 (d, C-7), 60.6 (t,  $\text{OCH}_2\text{CH}_3$ ), 58.4 (q, OMe), 29.0 (t, C-5), 24.1 (t, C-4), 18.0 (q, Me-8), 14.4 (q,  $\text{OCH}_2\text{CH}_3$ ), 12.5 (q, Me-2) ppm;

**HRMS-ESI**  $m/z$  for  $\text{C}_{14}\text{H}_{24}\text{O}_4\text{Na}$  [ $\text{M}+\text{Na}$ ] $^+$  calc. 279.1573, found 279.1570.

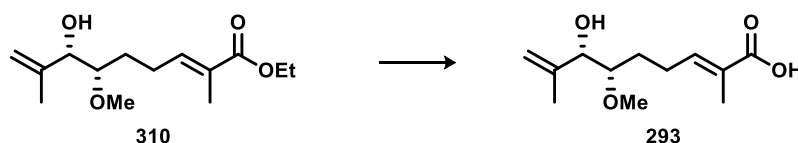
**(6*S*,7*S*,*E*)-7-Hydroxy-6-methoxy-2,8-dimethylnona-2,8-dienoic acid (293)**

Ester **310** (22 mg, 0.084 mmol, 1.0 eq.) was dissolved in THF/MeOH (1:1, 4 mL) and an aqueous LiOH solution (1.0 M, 840  $\mu$ L, 10.0 eq.) was added. The mixture was heated to 40 °C and stirred overnight. Water (1 mL) was added and the solution was acidified with an aqueous 1 M HCl solution to pH 2. The aqueous phase was extracted with EtOAc (3 x 5 mL). The combined organic phases were dried over  $\text{MgSO}_4$ , filtered and the solvent was removed under reduced pressure. The crude product was purified by flash column chromatography (PE/EtOAc = 2:1, 1% AcOH) to yield acid **293** (13 mg, 0.059 mmol, 70%) as a pale yellow oil.

The analytical data are consistent with those reported on page 180.

**(2*S*,4*S*,5*S*,6*S*)-5-((*tert*-Butyldimethylsilyl)oxy)-4-methoxy-2,6-dimethylnon-7-yn-1-yl 2,4,6-triisopropylbenzoate (**193**)**

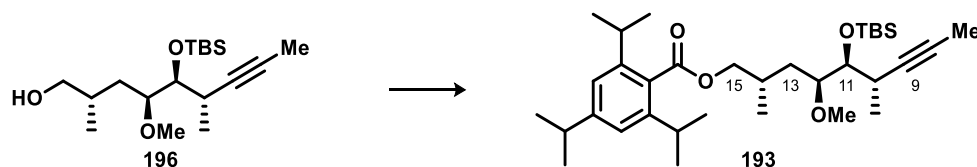

Alcohol **196** (12.0 mg, 36.5  $\mu\text{mol}$ , 1.0 eq.) was dissolved in THF (0.5 mL) and TIBOH (9.3 mg, 36.5  $\mu\text{mol}$ , 1.0 eq.) and  $\text{PPh}_3$  (9.6 mg, 36.5  $\mu\text{mol}$ , 1.0 eq.) were added. The mixture was cooled to 0  $^\circ\text{C}$  and DIAD (7.6  $\mu\text{L}$ , 36.5  $\mu\text{mol}$ , 1.0 eq.) was added. The reaction was allowed to reach room temperature and stirred overnight. The reaction was diluted with MTBE and terminated by the addition of a saturated aqueous  $\text{NaHCO}_3$  solution. The phases were separated and the aqueous phase was extracted with MTBE (3 x 10 mL). The combined organic phases were dried over  $\text{MgSO}_4$ , filtered and the solvent was removed under reduced pressure. The crude product was purified by flash column chromatography (PE/EtOAc = 10:1  $\rightarrow$  4:1) to yield benzoate **193** (10.9 mg, 20.0  $\mu\text{mol}$ , 53%, 89% brsm) as a yellow oil which was of sufficient purity to be used in the next step.

$R_f$  = 0.7 (PE/EtOAc = 10:1);

$^1\text{H-NMR}$  (500 MHz,  $\text{CDCl}_3$ ,  $\text{CHCl}_3$  = 7.26 ppm):  $\delta$  7.00 (s, 2H,  $\text{H}_{\text{Ar}}$ ), 4.21 (dd,  $J$  = 10.7, 5.3 Hz, 1H, H-15), 4.13 (dd,  $J$  = 10.7, 6.8 Hz, 1H, H-15'), 3.74 (t,  $J$  = 5.1 Hz, 1H, H-11), 3.36 (s, 3H, OMe), 3.34 – 3.31 (m, 1H, H-12), 2.92 – 2.82 (m, 3H, *i*-Pr), 2.66 – 2.57 (m, 1H, H-10), 2.10 – 2.03 (m, 1H, H-14), 1.76 (d,  $J$  = 2.4 Hz, 3H, Me-8), 1.61 – 1.54 (m, 2H, H-13), 1.24 (s, 18H, *i*-Pr), 1.12 (d,  $J$  = 6.9 Hz, 3H, Me-10), 1.02 (d,  $J$  = 6.7 Hz, 3H, Me-14), 0.90 (s, 9H, TBS), 0.11 (s, 3H, TBS), 0.09 (s, 3H, TBS) ppm;

**HRMS-ESI**  $m/z$  for  $\text{C}_{34}\text{H}_{58}\text{O}_4\text{SiNa}$  [ $\text{M}+\text{Na}$ ] $^+$  calc. 581.4002, found 581.4000.

***tert*-Butyl(3-((2*S*,4*S*,5*S*,6*S*)-5-((*tert*-butyldimethylsilyl)oxy)-4-methoxy-2,6-dimethyl-1-(4,4,5,5-tetramethyl-1,3,2-dioxaborolan-2-yl)non-7-yn-1-yl)phenoxy)dimethylsilane (**194**)**

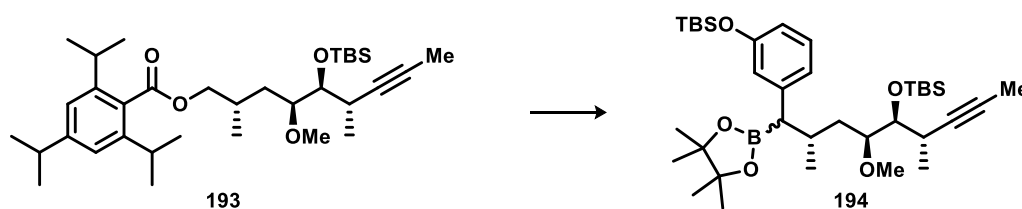

Benzoate **193** (6.0 mg, 10.7  $\mu\text{mol}$ , 1.0 eq.) was dissolved in  $\text{Et}_2\text{O}$  (0.8 mL) in a microwave vial. TMEDA<sup>23</sup> (2.4  $\mu\text{L}$ , 16.1  $\mu\text{mol}$ , 1.5 eq.) was added and the mixture was cooled to  $-78$   $^\circ\text{C}$ . *s*-BuLi (11.6  $\mu\text{L}$ , 15.0  $\mu\text{mol}$ , 1.4 eq.) was added dropwise and the mixture turned deep orange immediately. Stirring was continued at this temperature for 5 h. A solution of the boronic ester **164** (5.4 mg, 16.1  $\mu\text{mol}$ , 1.5 eq.) in  $\text{Et}_2\text{O}$  (500  $\mu\text{L}$ ) was added dropwise and stirring was

<sup>23</sup> Freshly distilled over  $\text{CaH}_2$ .



continued at  $-78\text{ }^{\circ}\text{C}$  for 2.5 h. The orange mixture was allowed to reach room temperature and turned colorless. Stirring was continued for 30 min at room temperature. The solvent was removed by adding a second needle to the septum and applying a stream of argon. Upon almost complete dryness, the outlet needle was removed and residual solvent was removed under high vacuum.  $\text{CHCl}_3$  (0.8 mL) was added and the mixture turned turbid. The mixture was stirred under refluxing conditions for 18 h. Product formation was detected by LCMS and HRMS. The mixture was cooled to  $0\text{ }^{\circ}\text{C}$  and was diluted with  $\text{Et}_2\text{O}$  (5 mL). The reaction was carefully (!) terminated by the addition of a 1.0 M  $\text{KH}_2\text{PO}_4$  solution (2-3 mL). The phases were separated and the aqueous phase was extracted with  $\text{Et}_2\text{O}$  (3 x 5 mL). The combined organic phases were dried over  $\text{MgSO}_4$ , filtered and the solvent was removed under reduced pressure. The product **194** could not be separated from the starting materials by flash column chromatography with different eluent systems. The crude mixture was used in the next step without further purification.

**HRMS-ESI**  $m/z$  for  $\text{C}_{36}\text{H}_{65}\text{BO}_5\text{Si}_2\text{Na}$   $[\text{M}+\text{Na}]^+$  calc. 667.4362, found 667.4009;  $m/z$  for  $\text{C}_{36}\text{H}_{65}\text{BO}_5\text{Si}_2\text{K}$   $[\text{M}+\text{K}]^+$  calc. 683.4101, found 683.4106.

### 3-((2*R*,4*S*,5*S*,6*S*)-5-Hydroxy-4-methoxy-2,6-dimethylnon-7-yn-1-yl)phenol (**195**)

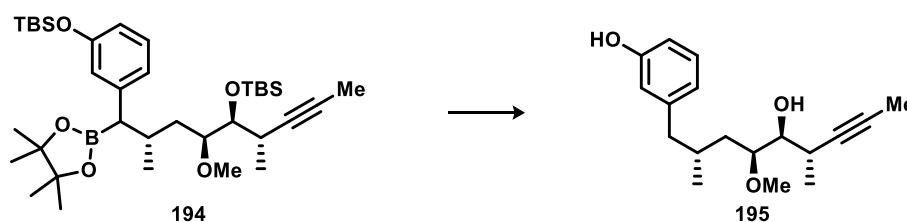

The crude mixture containing boronic ester **194** was dissolved in PhMe (2 mL) and TBAF $\cdot$ 3H $_2$ O (23 mg, 72.2  $\mu\text{mol}$ , 6.75 eq.)<sup>24</sup> was added. The mixture was stirred under refluxing conditions for 5 h. The reaction was terminated by the addition of water. The phases were separated and the aqueous phase was extracted with  $\text{CH}_2\text{Cl}_2$  (3 x 5 mL). The combined organic phases were dried over  $\text{MgSO}_4$ , filtered and the solvent was removed under reduced pressure. Diol **195** was detected by HRMS but could not be recovered after flash column chromatography.

**HRMS-ESI**  $m/z$  for  $\text{C}_{18}\text{H}_{26}\text{O}_3\text{Na}$   $[\text{M}+\text{Na}]^+$  calc. 313.1780, found 313.1783.

<sup>24</sup> Typically, TBAF $\cdot$ 3H $_2$ O is used in small excess (1.5 eq.) for protodeboronations. Since the arylboronic ester was used in the borylation step in 1.5-fold excess, the theoretical amount of "TBAF-consuming" groups in the mixture is 4.5 moles (1.5 moles Bpin + 1.5 moles TBS<sub>phenol</sub> + 1.0 moles TBS<sub>homopropargylic alcohol</sub>). The required amount of TBAF: 4.5 moles x 1.5 = 6.75 moles.

## 6 References

- [1] F. Bray, J. Ferlay, I. Soerjomataram, R. L. Siegel, L. A. Torre, A. Jemal, *CA. Cancer J. Clin.* **2018**, *68*, 394–424.
- [2] C.-H. Pui, C. G. Mullighan, W. E. Evans, M. V. Relling, *Blood* **2012**, *120*, 1165–1174.
- [3] K. Masui, B. Gini, J. Wykosky, C. Zanca, P. S. Mischel, F. B. Furnari, W. K. Cavenee, *Carcinogenesis* **2013**, *34*, 725–738.
- [4] J. P. Hendrick, F.-U. Hartl, *Annu. Rev. Biochem.* **1993**, *62*, 349–384.
- [5] S. S. Evans, E. A. Repasky, D. T. Fisher, *Nat. Rev. Immunol.* **2015**, *15*, 335–349.
- [6] F. Ritossa, *Experientia* **1962**, *18*, 571–573.
- [7] C. Wu, *Annu. Rev. Cell Dev. Biol.* **1995**, *11*, 441–469.
- [8] S. K. Calderwood, Y. Wang, X. Xie, M. A. Khaleque, S. D. Chou, A. Murshid, T. Prince, Y. Zhang, *Sign. Transduct. Insights* **2010**, *2*, 13–24.
- [9] J. Zou, Y. Guo, T. Guettouche, D. F. Smith, R. Voellmy, *Cell* **1998**, *94*, 471–480.
- [10] P. K. Sorger, H. R. B. Pelham, *Cell* **1988**, *54*, 855–864.
- [11] J. T. Westwood, C. Wu, *Mol. Cell. Biol.* **1993**, *13*, 3481–3486.
- [12] D. F. Nathan, M. H. Vos, S. Lindquist, *Proc. Natl. Acad. Sci. U. S. A.* **1997**, *94*, 12949–12956.
- [13] L. Whitesell, S. L. Lindquist, *Nat. Rev. Cancer* **2005**, *5*, 761–772.
- [14] L. H. Pearl, C. Prodromou, P. Workman, *Biochem. J.* **2008**, *410*, 439–453.
- [15] D. Hanahan, R. A. Weinberg, *Cell* **2000**, *100*, 57–70.
- [16] S. Takayama, J. C. Reed, S. Homma, *Oncogene* **2003**, *22*, 9041–9047.
- [17] D. R. Ciocca, A. P. Arrigo, S. K. Calderwood, *Arch. Toxicol.* **2013**, *87*, 19–48.
- [18] J. C. Young, I. Moarefi, F. U. Hartl, *J. Cell Biol.* **2001**, *154*, 267–273.
- [19] K. Sidera, E. Patsavoudi, *Recent Pat. Anticancer. Drug Discov.* **2014**, *9*, 1–20.
- [20] J. Trepel, M. Mollapour, G. Giaccone, L. Neckers, *Nat. Rev. Cancer* **2010**, *10*, 537–549.
- [21] C. Prodromou, S. M. Roe, R. O’Brien, J. E. Ladbury, P. W. Piper, L. H. Pearl, *Cell* **1997**, *90*, 65–75.
- [22] C. E. Stebbins, A. A. Russo, C. Schneider, N. Rosen, F. U. Hartl, N. P. Pavletich, *Cell* **1997**, *89*, 239–250.
- [23] J. G. Supko, R. L. Hickman, M. R. Grever, L. Malspeis, *Cancer Chemother. Pharmacol.* **1995**, *36*, 305–315.
- [24] L. Neckers, T. W. Schulte, E. Mimnaugh, *Invest. New Drugs* **1999**, *17*, 361–373.
- [25] J. R. Porter, C. C. Fritz, K. M. Depew, *Curr. Opin. Chem. Biol.* **2010**, *14*, 412–420.

- [26] K. J. Meyer, E. Caton, T. A. Shapiro, *Antimicrob. Agents Chemother.* **2018**, *62*, DOI 10.1128/AAC.00056-18.
- [27] A. Rascher, Z. Hu, N. Viswanathan, A. Schirmer, R. Reid, W. C. Nierman, M. Lewis, C. R. Hutchinson, *FEMS Microbiol. Lett.* **2003**, *218*, 223–230.
- [28] A. Rascher, Z. Hu, G. O. Buchanan, R. Reid, C. R. Hutchinson, *Appl. Environ. Microbiol.* **2005**, *71*, 4862–4871.
- [29] T. W. Yu, R. Müller, M. Müller, X. Zhang, G. Dräger, C. G. Kim, E. Leistner, H. G. Floss, *J. Biol. Chem.* **2001**, *276*, 12546–55.
- [30] H. G. Floss, T.-W. Yu, K. Arakawa, *J. Antibiot. (Tokyo)*. **2011**, *64*, 35–44.
- [31] Y. S. Hong, D. Lee, W. Kim, J. K. Jeong, C. G. Kim, J. K. Sohng, J. H. Lee, S.-G. Paik, J. J. Lee, *J. Am. Chem. Soc.* **2004**, *126*, 11142–11143.
- [32] S. Eichner, T. Eichner, H. G. Floss, J. Fohrer, E. Hofer, F. Sasse, C. Zeilinger, A. Kirschning, *J. Am. Chem. Soc.* **2012**, *134*, 1673–1679.
- [33] J. C. Sinclair, J. Sandy, R. Delgoda, E. Sim, M. E. M. Noble, *Nat. Struct. Biol.* **2000**, *7*, 560–564.
- [34] E. Sim, J. Sandy, D. Evangelopoulos, E. Fullam, S. Bhakta, I. Westwood, A. Krylova, N. Lack, M. Noble, *Curr. Drug Metab.* **2008**, *9*, 510–519.
- [35] E. Sim, G. Fakis, N. Laurieri, S. Boukouvala, in *Adv. Pharmacol.*, Academic Press Inc., **2012**, pp. 169–205.
- [36] A. Kawamura, J. Graham, A. Mushtaq, S. A. Tsiftoglou, G. M. Vath, P. E. Hanna, C. R. Wagner, E. Sim, *Biochem. Pharmacol.* **2005**, *69*, 347–359.
- [37] H. Wang, C. R. Wagner, P. E. Hanna, *Chem. Res. Toxicol.* **2005**, *18*, 183–197.
- [38] D. W. Hein, C. A. McQueen, D. M. Grant, G. H. Goodfellow, F. F. Kadlubar, W. W. Weber, *Drug Metab. Dispos.* **2000**, *28*.
- [39] M. Payton, A. Mushtaq, T. W. Yu, L. J. Wu, J. C. Sinclair, E. Sim, *Microbiology* **2001**, *147*, 1137–1147.
- [40] E. Sim, K. Walters, S. Boukouvala, *Drug Metab. Rev.* **2008**, *40*, 479–510.
- [41] B. Pluinage, J. Dairou, O. M. Possot, M. Martins, A. Fouet, J. M. Dupret, F. Rodrigues-Lima, *Biochemistry* **2007**, *46*, 7069–7078.
- [42] M. Payton, R. Auty, R. Delgoda, M. Everett, S. Edith, *J. Bacteriol.* **1999**, *181*, 1343–1347.
- [43] J. Sandy, A. Mushtaq, S. J. Holton, P. Schartau, M. E. M. Noble, E. Sim, *Biochem. J.* **2005**, *390*, 115–123.
- [44] H. Wang, G. M. Vath, K. J. Gleason, P. E. Hanna, C. R. Wagner, *Biochemistry* **2004**, *43*, 8234–8246.
- [45] H. Wang, L. Liu, P. E. Hanna, C. R. Wagner, *Biochemistry* **2005**, *44*, 11295–11306.
- [46] A. L. Sikora, B. A. Frankel, J. S. Blanchard, *Biochemistry* **2008**, *47*, 10781–10789.
- [47] S. J. Holton, J. Dairou, J. Sandy, F. Rodrigues-Lima, J. M. Dupret, M. E. M. Noble, E. Sim, *Acta Crystallogr. Sect. F Struct. Biol. Cryst. Commun.* **2005**, *61*, 14–16.

- [48] F. Rodrigues-Lima, C. Deloménie, G. H. Goodfellow, D. M. Grant, J.-M. Dupret, *Biochem. J.* **2001**, *356*, 327–334.
- [49] J. Dairou, D. Flatters, A. F. Chaffotte, B. Pluvinage, E. Sim, J.-M. Dupret, F. Rodrigues-Lima, *FEBS Lett.* **2006**, *580*, 1780–1788.
- [50] H. Wu, L. Dombrovsky, W. Tempel, F. Martin, P. Loppnau, G. H. Goodfellow, D. M. Grant, A. N. Plotnikov, *J. Biol. Chem.* **2007**, *282*, 30189–30197.
- [51] E. Sim, N. Lack, C. J. Wang, H. Long, I. Westwood, E. Fullam, A. Kawamura, *Toxicology* **2008**, *254*, 170–183.
- [52] X. Kubiak, J. Dairou, J. M. Dupret, F. Rodrigues-Lima, *Expert Opin. Drug Metab. Toxicol.* **2013**, *9*, 349–362.
- [53] E. Higashide, M. Asai, K. Ootsu, S. Tanida, Y. Kozai, T. Hasegawa, T. Kishi, Y. Sugino, M. Yoneda, *Nature* **1977**, *270*, 721–722.
- [54] P. R. August, L. Tang, Y. J. Yoon, S. Ning, R. Müller, T. Yu, M. Taylor, D. Hoffmann, C. Kim, X. Zhang, C. R. Hutchinson, H. G. Floss, *Chem. Biol.* **1998**, *5*, 69–79.
- [55] F. Pompeo, A. Mushtaq, E. Sim, *Protein Expr. Purif.* **2002**, *24*, 138–151.
- [56] T.-W. Yu, L. Bai, D. Clade, D. Hoffmann, S. Toelzer, K. Q. Trinh, J. Xu, S. J. Moss, E. Leistner, H. G. Floss, *Proc. Natl. Acad. Sci. U. S. A.* **2002**, *99*, 7968–7973.
- [57] F. Wesemann, A. Heutling, P. Wienecke, A. Kirschning, *ChemBioChem* **2020**, *21*, 2927–2930.
- [58] A. Kirschning, F. Hahn, *Angew. Chemie* **2012**, *124*, 4086–4096.
- [59] E. Fullam, I. M. Westwood, M. C. Anderton, E. D. Lowe, E. Sim, M. E. M. Noble, *J. Mol. Biol.* **2008**, *375*, 178–191.
- [60] W. Ewert, PhD Thesis, Medizinische Hochschule Hannover, **2020**.
- [61] M. E. Horsman, T. P. A. Hari, C. N. Boddy, *Nat. Prod. Rep.* **2016**, *33*, 183–202.
- [62] J. W. Trauger, R. M. Kohli, H. D. Mootz, M. A. Marahiel, C. T. Walsh, *Nature* **2000**, *407*, 215–218.
- [63] R. M. Kohli, J. W. Trauger, D. Schwarzer, M. A. Marahiel, C. T. Walsh, *Biochemistry* **2001**, *40*, 7099–7108.
- [64] R. M. Kohli, M. D. Burke, J. Tao, C. T. Walsh, *J. Am. Chem. Soc.* **2003**, *125*, 7160–7161.
- [65] C. Mahlert, S. A. Sieber, J. Grünwald, M. A. Marahiel, *J. Am. Chem. Soc.* **2005**, *127*, 9571–9580.
- [66] F. Kopp, M. A. Marahiel, *Curr. Opin. Biotechnol.* **2007**, *18*, 513–520.
- [67] D. Mandalapu, X. Ji, J. Chen, C. Guo, W. Q. Liu, W. Ding, J. Zhou, Q. Zhang, *J. Org. Chem.* **2018**, *83*, 7271–7275.
- [68] L. Qiao, J. Fang, P. Zhu, H. Huang, C. Dang, J. Pang, W. Gao, X. Qiu, L. Huang, Y. Li, *Protein J.* **2019**, *38*, 658–666.
- [69] G. W. Heberlig, J. T. C. Brown, R. D. Simard, M. Wirz, W. Zhang, M. Wang, L. I. Susser, M. E. Horsman, C. N. Boddy, *Org. Biomol. Chem.* **2018**, *16*, 5771–5779.

- [70] G. W. Heberlig, M. Wirz, M. Wang, C. N. Boddy, *Org. Lett.* **2014**, *16*, 5858–5861.
- [71] D. W. Gao, C. S. Jamieson, G. Wang, Y. Yan, J. Zhou, K. N. Houk, Y. Tang, *J. Am. Chem. Soc.* **2021**, *143*, 84.
- [72] G. Illuminati, L. Mandolini, *Acc. Chem. Res.* **1981**, *14*, 95–102.
- [73] G. A. Molander, *Acc. Chem. Res.* **1998**, *31*, 603–609.
- [74] N. L. Allinger, M. T. Tribble, M. A. Miller, D. H. Wertz, *J. Am. Chem. Soc.* **1971**, *93*, 1637–1648.
- [75] J. Hermane, PhD Thesis, Leibniz Universität Hannover, **2013**.
- [76] J. J. Schmidt, Y. Khatri, S. I. Brody, C. Zhu, H. Pietraszkiwicz, F. A. Valeriotte, D. H. Sherman, *ACS Chem. Biol.* **2020**, *15*, 524–532.
- [77] S. Yue, J. S. Duncan, Y. Yamamoto, C. R. Hutchinson, *J. Am. Chem. Soc.* **1987**, *109*, 1253–1255.
- [78] M. Vogt, PhD Thesis, Leibniz Universität Hannover, **2010**.
- [79] S. Ceylan, PhD Thesis, Leibniz Universität Hannover, **2011**.
- [80] I. Bułyszko, PhD Thesis, Leibniz Universität Hannover, **2016**.
- [81] C. Lecourt, S. Dhambri, L. Allievi, Y. Sanogo, N. Zeghib, R. Ben Othman, M. I. Lannou, G. Sorin, J. Ardisson, *Nat. Prod. Rep.* **2018**, *35*, 105–124.
- [82] R. Matsui, K. Seto, Y. Sato, T. Suzuki, A. Nakazaki, S. Kobayashi, *Angew. Chemie Int. Ed.* **2011**, *50*, 680–683.
- [83] D. A. Evans, M. D. Ennis, D. J. Mathre, *J. Am. Chem. Soc.* **1982**, *104*, 1737–1739.
- [84] A. G. Myers, B. H. Yang, H. Chen, L. McKinstry, D. J. Kopecky, J. L. Gleason, *J. Am. Chem. Soc.* **1997**, *119*, 6496–6511.
- [85] J. T. Reeves, Z. Tan, Z. S. Han, G. Li, Y. Zhang, Y. Xu, D. C. Reeves, N. C. Gonnella, S. Ma, H. Lee, B. Z. Lu, C. H. Senanayake, *Angew. Chemie Int. Ed.* **2012**, *51*, 1400–1404.
- [86] R. I. Hogrefe, A. P. Mccaffrey, L. U. Borozdina, E. S. Mccampbell, M. M. Vaghefi, *Nucleic Acids Res.* **1993**, *21*, 4739–4741.
- [87] D. Zhao, D. Lei, P. Wang, S. Li, H. Zhang, X. Cui, *ChemistrySelect* **2019**, *4*, 5853–5859.
- [88] I. E. Wrona, A. E. Gabarda, G. Evano, J. S. Panek, *J. Am. Chem. Soc.* **2005**, *127*, 15026–15027.
- [89] W. R. Roush, K. Ando, D. B. Powers, A. D. Palkowitz, R. L. Halterman, *J. Am. Chem. Soc.* **1990**, *112*, 6339–6348.
- [90] R. Matsui, K. Seto, K. Fujita, T. Suzuki, A. Nakazaki, S. Kobayashi, *Angew. Chemie Int. Ed.* **2010**, *49*, 10068–10073.
- [91] J. A. Marshall, X.-J. Wang, *J. Org. Chem.* **1992**, *5755*, 1242–1252.
- [92] J. A. Marshall, *Chem. Rev.* **1996**, *96*, 31–48.
- [93] J. A. Marshall, in *Chem. Organozinc Compd.* (Eds.: Z. Rappoport, I. Marek), John

- Wiley & Sons, Ltd, Chichester, UK, **2007**, pp. 421–455.
- [94] J. A. Marshall, *J. Org. Chem.* **2007**, *72*, 8153–8166.
- [95] J. A. Marshall, X. J. Wang, *J. Org. Chem.* **1990**, *55*, 6246–6248.
- [96] J. A. Marshall, X. J. Wang, *J. Org. Chem.* **1991**, *56*, 3211–3213.
- [97] J. A. Marshall, J. Perkins, *J. Org. Chem.* **1994**, *59*, 3509–3511.
- [98] G. W. Gribble, H. H. Joyner, F. L. Switzer, *Synth. Commun.* **1992**, *22*, 2997–3002.
- [99] T. R. Hoye, C. S. Jeffrey, F. Shao, *Nat. Protoc.* **2007**, *2*, 2451–2458.
- [100] X. Liu, J. M. Ready, *Tetrahedron* **2008**, *64*, 6955–6960.
- [101] J. K. Belardi, G. C. Micalizio, *Angew. Chemie Int. Ed.* **2008**, *47*, 4005–4008.
- [102] A. G. Myers, B. H. Yang, D. J. Kopecky, *Tetrahedron Lett.* **1996**, *37*, 3623–3626.
- [103] A. Claesson, L.-I. Olsson, *J. Chem. Soc. Chem. Commun.* **1979**, 524.
- [104] Z. Huang, E. I. Negishi, *Org. Lett.* **2006**, *8*, 3675–3678.
- [105] Y. Okude, S. Hirano, T. Hiyama, H. Nozaki, *J. Am. Chem. Soc.* **1977**, *99*, 3179–3181.
- [106] T. Hiyama, Y. Okude, K. Kimura, H. Nozaki, *Bull. Chem. Soc. Jpn.* **1982**, *55*, 561–568.
- [107] H. Jin, J. I. Uenishi, W. J. Christ, Y. Kishi, *J. Am. Chem. Soc.* **1986**, *108*, 5644–5646.
- [108] A. Gil, F. Albericio, M. Álvarez, *Chem. Rev.* **2017**, *117*, 8420–8446.
- [109] A. Fürstner, *Chem. Rev.* **1999**, *99*, 991–1045.
- [110] Q. Tian, G. Zhang, *Synthesis (Stuttg.)* **2016**, *48*, 4038–4049.
- [111] K. Takai, M. Tagashira, T. Kuroda, K. Oshima, K. Utimoto, H. Nozaki, *J. Am. Chem. Soc.* **1986**, *108*, 6048–6050.
- [112] Z. K. Wan, H. W. Choi, F. A. Kang, K. Nakajima, D. Demeke, Y. Kishi, *Org. Lett.* **2002**, *4*, 4431–4434.
- [113] T. Schmidt, A. Kirschning, *Angew. Chemie Int. Ed.* **2012**, *51*, 1063–1066.
- [114] T. Schmidt, PhD Thesis, Leibniz Universität Hannover, **2012**.
- [115] J. Ammermann, PhD Thesis, Leibniz Universität Hannover, **2017**.
- [116] G. C. Hargaden, P. J. Guiry, *Adv. Synth. Catal.* **2007**, *349*, 2407–2424.
- [117] E. J. Corey, R. K. Bakshi, S. Shibata, *J. Am. Chem. Soc.* **1987**, *109*, 5551–5553.
- [118] E. J. Corey, C. J. Helal, *Angew. Chemie Int. Ed.* **1998**, *37*, 1986–2012.
- [119] S. Masamune, W. Choy, J. S. Petersen, L. R. Sita, *Angew. Chemie Int. Ed.* **1985**, *24*, 1–30.
- [120] M. Rottländer, L. Boymond, G. Cahiez, P. Knochel, *J. Org. Chem.* **1999**, *64*, 1080–1081.
- [121] C. Gaul, J. T. Njardarson, D. Shan, D. C. Dorn, K. Da Wu, W. P. Tong, X. Y. Huang, M. A. S. Moore, S. J. Danishefsky, *J. Am. Chem. Soc.* **2004**, *126*, 11326–11337.

- [122] M. Jørgensen, E. H. Iversen, A. L. Paulsen, R. Madsen, *J. Org. Chem.* **2001**, *66*, 4630–4634.
- [123] F. Yang, L. Feng, N. Wang, X. Liu, J. Li, Y. Shen, *Tetrahedron* **2013**, *69*, 9463–9468.
- [124] A. B. Bahadoor, A. Flyer, G. C. Micalizio, *J. Am. Chem. Soc.* **2005**, *127*, 3694–3695.
- [125] A. B. Bahadoor, G. C. Micalizio, *Org. Lett.* **2006**, *8*, 1181–1184.
- [126] N. Miyaura, A. Suzuki, *Chem. Rev.* **1995**, *95*, 2457–2483.
- [127] A. Suzuki, *Angew. Chemie Int. Ed.* **2011**, *50*, 6723–6733.
- [128] A. Ariaifard, Z. Lin, *Organometallics* **2006**, *25*, 4030–4033.
- [129] R. G. Pearson, P. E. Figdore, *J. Am. Chem. Soc.* **1980**, *102*, 1541–1547.
- [130] L. C. Campeau, N. Hazari, *Organometallics* **2019**, *38*, 3–35.
- [131] N. Kambe, T. Iwasaki, J. Terao, *Chem. Soc. Rev.* **2011**, *40*, 4937–4947.
- [132] A. Rudolph, M. Lautens, *Angew. Chemie Int. Ed.* **2009**, *48*, 2656–2670.
- [133] A. C. Frisch, M. Beller, *Angew. Chemie Int. Ed.* **2005**, *44*, 674–688.
- [134] M. R. Netherton, G. C. Fu, *Top. Organomet. Chem.* **2005**, 85–108.
- [135] X. Hu, *Chem. Sci.* **2011**, *2*, 1867–1886.
- [136] F. S. Han, *Chem. Soc. Rev.* **2013**, *42*, 5270–5298.
- [137] B. S. Kadu, *Catal. Sci. Technol.* **2021**, *11*, 1186–1221.
- [138] C.-T. Yang, Z.-Q. Zhang, Y.-C. Liu, L. Liu, *Angew. Chemie Int. Ed.* **2011**, *50*, 3904–3907.
- [139] C.-T. Yang, Z.-Q. Zhang, H. Tajuddin, C.-C. Wu, J. Liang, J. H. Liu, Y. Fu, M. Czyzewska, P. G. Steel, T. B. Marder, L. Liu, *Angew. Chemie Int. Ed.* **2012**, *51*, 528–532.
- [140] J. Zhou, G. C. Fu, *J. Am. Chem. Soc.* **2004**, *126*, 1340–1341.
- [141] D. W. Robbins, J. F. Hartwig, *Angew. Chemie Int. Ed.* **2013**, *52*, 933–937.
- [142] X. Liu, Z. Yang, Y. M. Li, F. Yang, L. Feng, N. Wang, D. Ma, K. J. Chang, Y. Shen, *Tetrahedron* **2014**, *70*, 9522–9529.
- [143] D. A. Everson, B. A. Jones, D. J. Weix, *J. Am. Chem. Soc.* **2012**, *134*, 6146–6159.
- [144] J. H. Kirchhoff, M. R. Netherton, I. D. Hills, G. C. Fu, *J. Am. Chem. Soc.* **2002**, *124*, 13662–13663.
- [145] C.-T. Yang, Z.-Q. Zhang, Y.-C. Liu, L. Liu, *Angew. Chemie Int. Ed.* **2011**, *50*, 3904–3907.
- [146] Q. Li, C. W. Liskey, J. F. Hartwig, *J. Am. Chem. Soc.* **2014**, *136*, 8755–8765.
- [147] S. Laulhé, J. M. Blackburn, J. L. Roizen, *Org. Lett.* **2016**, *18*, 4440–4443.
- [148] K. Tamao, K. Sumitani, M. Kumada, *J. Am. Chem. Soc.* **1972**, *94*, 4374–4376.
- [149] A. Fürstner, *Angew. Chemie Int. Ed.* **2009**, *48*, 1364–1367.

- [150] W. M. Czaplik, M. Mayer, A. J. Von Wangelin, *Angew. Chemie Int. Ed.* **2009**, *48*, 607–610.
- [151] J. Barbier, R. Jansen, H. Irschik, S. Benson, K. Gerth, B. Böhlendorf, G. Höfle, H. Reichenbach, J. Wegner, C. Zeilinger, A. Kirschning, R. Müller, *Angew. Chemie Int. Ed.* **2012**, *51*, 1256–1260.
- [152] C. A. Brooks, M. Cheung, H. S. Eidam, R. M. Fox, M. A. Hilfker, E. S. Manas, G. Ye, *WO2011/119704*, **2011**.
- [153] A. P. Ingale, V. K. More, U. S. Gangarde, S. V. Shinde, *New J. Chem.* **2018**, *42*, 10142–10147.
- [154] G. Sabitha, C. S. Reddy, J. S. Yadav, *Tetrahedron Lett.* **2006**, *47*, 4513–4516.
- [155] R. R. Hill, S. D. Rychnovsky, *J. Org. Chem.* **2016**, *81*, 10707–10714.
- [156] R. Larouche-Gauthier, C. J. Fletcher, I. Couto, V. K. Aggarwal, *Chem. Commun.* **2011**, *47*, 12592–12594.
- [157] S. Nave, R. P. Sonawane, T. G. Elford, V. K. Aggarwal, *J. Am. Chem. Soc.* **2010**, *132*, 17096–17098.
- [158] S. Roesner, D. J. Blair, V. K. Aggarwal, *Chem. Sci.* **2015**, *6*, 3718–3723.
- [159] S. Roesner, J. M. Casatejada, T. G. Elford, R. P. Sonawane, V. K. Aggarwal, *Org. Lett.* **2011**, *13*, 5740–5743.
- [160] U. Ragnarsson, L. Grehn, *RSC Adv.* **2013**, *3*, 18691–18697.
- [161] B. H. Rotstein, L. Wang, R. Y. Liu, J. Patteson, E. E. Kwan, N. Vasdev, S. H. Liang, *Chem. Sci.* **2016**, *7*, 4407–4417.
- [162] Y. Basel, A. Hassner, *J. Org. Chem.* **2000**, *65*, 6368–6380.
- [163] D. S. Kemp, T. P. Curran, *J. Org. Chem.* **1988**, *53*, 5729–5731.
- [164] E. Guibé-Jampel, M. Wakselman, *Synthesis (Stuttg.)* **1977**, *1977*, 772.
- [165] S. Kim, J. I. Lee, Y. C. Kim, *J. Org. Chem.* **1985**, *50*, 560–565.
- [166] M. Brünjes, PhD Thesis, Leibniz Universität Hannover, **2006**.
- [167] S. Djuric, J. Venit, P. Magnus, *Tetrahedron Lett.* **1981**, *22*, 1787–1790.
- [168] R. P. Bonar-Law, A. P. Davis, B. J. Dorgan, *Tetrahedron Lett.* **1990**, *31*, 6721–6724.
- [169] W. Huang, H. Yu, R. Sheng, J. Li, Y. Hu, *Bioorganic Med. Chem.* **2008**, *16*, 10190–10197.
- [170] D. A. Spiegel, K. B. Wiberg, L. N. Schacherer, M. R. Medeiros, J. L. Wood, *J. Am. Chem. Soc.* **2005**, *127*, 12513–12515.
- [171] T. Hampel, T. Neubauer, T. Van Leeuwen, T. Bach, *Chem. - A Eur. J.* **2012**, *18*, 10382–10392.
- [172] M. Szostak, M. Spain, D. J. Procter, *J. Org. Chem.* **2012**, *77*, 3049–3059.
- [173] T. Horneff, T. Bach, *Synlett* **2008**, *2008*, 2969–2972.
- [174] K. Harmrolfs, M. Brünjes, G. Dräger, H. G. Floss, F. Sasse, F. Taft, A. Kirschning,



- ChemBioChem* **2010**, *11*, 2517–2520.
- [175] N. M. Gaudelli, C. A. Townsend, *J. Org. Chem.* **2013**, *78*, 6412–6426.
- [176] W. Zhang, R. Shrestha, R. M. Buckley, J. Jewell, S. H. Bossmann, J. Stubbe, P. Li, *ACS Chem. Biol.* **2014**, *9*, 1773–1779.
- [177] F. Pfrengle, V. Dekaris, L. Schefzig, R. Zimmer, H. U. Reissig, *Synlett* **2008**, 2965–2968.
- [178] W. Ewert, C. Bartens, A. Heutling, J. Hermene, A. Kishore, C. Zeilinger, M. Preller, A. Kirschning, *Unpublished Work*, **n.d.**
- [179] S. Ni, N. M. Padial, C. Kingston, J. C. Vantourout, D. C. Schmitt, J. T. Edwards, M. M. Kruszyk, R. R. Merchant, P. K. Mykhailiuk, B. B. Sanchez, S. Yang, M. A. Perry, G. M. Gallego, J. J. Mousseau, M. R. Collins, R. J. Cherney, P. S. Lebed, J. S. Chen, T. Qin, P. S. Baran, *J. Am. Chem. Soc.* **2019**, *141*, 6726–6739.
- [180] H. Fischer, *Chem. Rev.* **2001**, *101*, 3581–3610.
- [181] A. Studer, *Chem. - A Eur. J.* **2001**, *7*, 1159–1164.
- [182] M. Vogt, PhD Thesis, Leibniz Universität Hannover, **2010**.
- [183] J. R. Gage, D. A. Evans, *Org. Synth.* **1990**, *68*, 83.
- [184] J. E. D. Kirkham, T. D. L. Courtney, V. Lee, J. E. Baldwin, *Tetrahedron* **2005**, *61*, 7219–7232.
- [185] J. K. Belardi, G. C. Micalizio, *Org. Lett.* **2006**, *8*, 2409–2412.
- [186] I. Fleming, D. Higgins, N. J. Lawrence, A. P. Thomas, *J. Chem. Soc. Perkin Trans. 1* **1992**, 3331–3349.
- [187] M. . T. Rahman, J. M. Cook, *European J. Org. Chem.* **2018**, *2018*, 3224–3229.
- [188] S. Roesner, C. A. Brown, M. Mohiti, A. P. Pulis, R. Rasappan, D. J. Blair, S. Phanie Essafi, D. Leonori, V. K. Aggarwal, *Chem. Commun.* **2014**, *50*, 4053–4055.
- [189] I. Fleming, K. Takaki, A. P. Thomas, *J. Chem. Soc. Perkin Trans. 1* **1987**, *3*, 2269–2273.
- [190] R. Fürst, U. Rinner, *J. Org. Chem.* **2013**, *78*, 8748–8758.
- [191] K. Tamao, A. Kawachi, Y. Nakagawa, Y. Ito, *J. Organomet. Chem.* **1994**, *473*, 29–34.
- [192] M. L. Filleux-Blanchard, N. D. An, *Org. Magn. Reson.* **1979**, *12*, 12–16.
- [193] G. D. Joly, E. N. Jacobsen, *Org. Lett.* **2002**, *4*, 1795–1798.
- [194] H. P. Wessel, T. Iversen, D. R. Bundle, *J. Chem. Soc. Perkin Trans. 1* **1985**, 2247–2250.
- [195] R. Rathore, C. L. Burns, *J. Org. Chem.* **2003**, *68*, 4071–4074.
- [196] H. Lu, A. Raja, R. Franke, D. Landsberg, F. Sasse, M. Kalesse, *Angew. Chemie Int. Ed.* **2013**, *52*, 13549–13552.
- [197] J. Pietruszka, A. Witt, *Synthesis (Stuttg.)* **2006**, *24*, 4266–4268.
- [198] U. Ravid, R. M. Silverstein, L. R. Smith, *Tetrahedron* **1978**, *34*, 1449–1452.

- [199] S. W. Haynes, P. K. Sydor, C. Corre, L. Song, G. L. Challis, *J. Am. Chem. Soc.* **2011**, *133*, 1793–1798.
- [200] R. A. Pilli, M. M. Victor, A. De Meijere, *J. Org. Chem.* **2000**, *65*, 5910–5916.
- [201] A. M. Becker, R. W. Rickards, *Tetrahedron* **1983**, *39*, 4189–4192.
- [202] T. Frenzel, M. Brünjes, M. Quitschalle, A. Kirschning, *Org. Lett.* **2006**, *8*, 135–138.
- [203] C. Bartens, Master Thesis, Leibniz Universität Hannover, **2017**.
- [204] F. Taft, M. Brünjes, T. Knobloch, H. G. Floss, A. Kirschning, *J. Am. Chem. Soc.* **2009**, *131*, 3812–3813.
- [205] A. Zampella, M. Sorgente, M. V. D'Auria, *Tetrahedron: Asymmetry* **2002**, *13*, 681–685.
- [206] D. A. Evans, R. L. Dow, T. L. Shih, J. M. Takacs, R. Zahler, *J. Am. Chem. Soc.* **1990**, *112*, 5290–5313.
- [207] L. Deng, X. Huang, G. Zhao, *J. Org. Chem.* **2006**, *71*, 4625–4635.
- [208] B. G. Vong, S. Abraham, A. X. Xiang, E. A. Theodorakis, *Org. Lett.* **2003**, *5*, 1617–1620.
- [209] S. Gu, H. Jing, J. Wu, Y. Liang, *Synth. Commun.* **1997**, *27*, 2793–2797.
- [210] Y. Lee, M. J. Kelly, *Tetrahedron Lett.* **2006**, *47*, 4897–4901.
- [211] F. Effenberger, M. Koch, W. Streicher, *Chem. Ber.* **1991**, *124*, 163–173.
- [212] M. Erra Sola, M. Carrascal Riera, J. Taltavull Moll, J. F. Caturla Javaloyes, F. J. Bernal Anchuela, L. M. Pages Santacana, M. Mir Cepeda, G. Casals Coll, M. B. Hernandez Olasagarre, *Pyrrrolotriazinone Derivatives As PI3K Inhibitors*, **2014**, WO 2014/060432 A1.
- [213] G. Besong, K. Jarowicki, P. J. Kocienski, E. Sliwinski, F. T. Boyle, *Org. Biomol. Chem.* **2006**, *4*, 2193–2207.
- [214] D. M. Roberts, C. Bartel, A. Scott, D. Ivison, T. J. Simpson, R. J. Cox, *Chem. Sci.* **2017**, *8*, 1116–1126.
- [215] W. Seubert, F. Lynen, *J. Am. Chem. Soc.* **1953**, *75*, 2787–2788.
- [216] J. M. Crawford, B. C. R. Dancy, E. A. Hill, D. W. Udway, C. A. Townsend, *Proc. Natl. Acad. Sci. U. S. A.* **2006**, *103*, 16728–16733.
- [217] A. L. Sewell, M. V. J. Villa, M. Matheson, W. G. Whittingham, R. Marquez, *Org. Lett.* **2011**, *13*, 800–803.
- [218] P. D. Walker, C. Williams, A. N. M. Weir, L. Wang, J. Crosby, P. R. Race, T. J. Simpson, C. L. Willis, M. P. Crump, *Angew. Chemie Int. Ed.* **2019**, *58*, 12446–12450.
- [219] A. J. Hill, S. R. Aspinall, *J. Am. Chem. Soc.* **1939**, *61*, 822–825.
- [220] B. Gutmann, J.-P. Roduit, D. Roberge, C. O. Kappe, *Chem. - A Eur. J.* **2011**, *17*, 13146–13150.
- [221] J. A. Valencia-Gallegos, M. M. Álvarez, V. J. Martínez-Merino, *Tetrahedron Lett.* **2015**, *56*, 6803–6806.

- [222] A. Dey, M. T. Kirchner, V. R. Vangala, G. R. Desiraju, R. Mondal, J. A. K. Howard, *J. Am. Chem. Soc.* **2005**, *127*, 10545–10559.
- [223] S. V. Ley, D. S. Brown, J. A. Clase, A. J. Fairbanks, I. C. Lennon, H. M. I. Osborn, E. S. E. Stokes, D. J. Wadsworth, *J. Chem. Soc. - Perkin Trans. 1* **1998**, 2259–2276.
- [224] A. V. Bekish, K. N. Prokhorevich, O. G. Kulinkovich, *European J. Org. Chem.* **2006**, *2006*, 5069–5075.
- [225] P. C. Echeverría, A. Bernthaler, P. Dupuis, B. Mayer, D. Picard, *PLoS One* **2011**, *6*, e26044.

## 7 Appendix

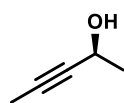

106

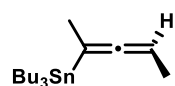
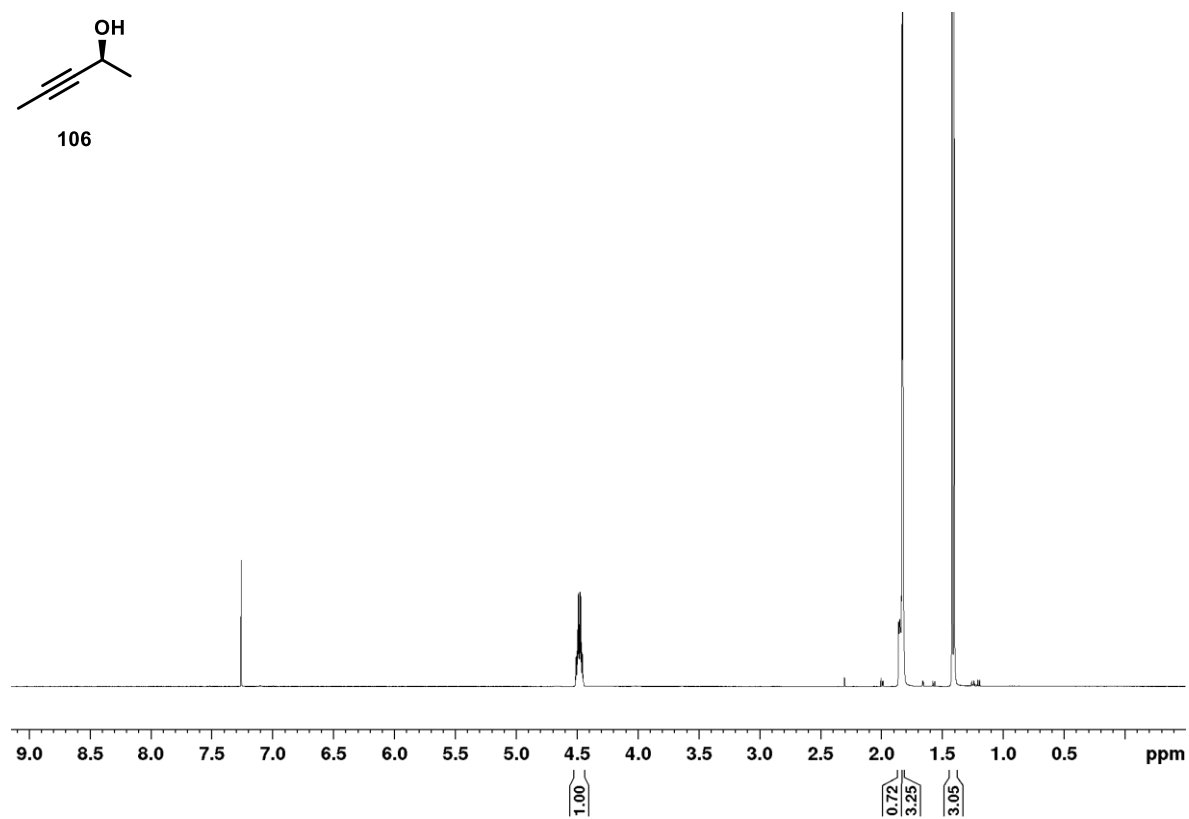

100

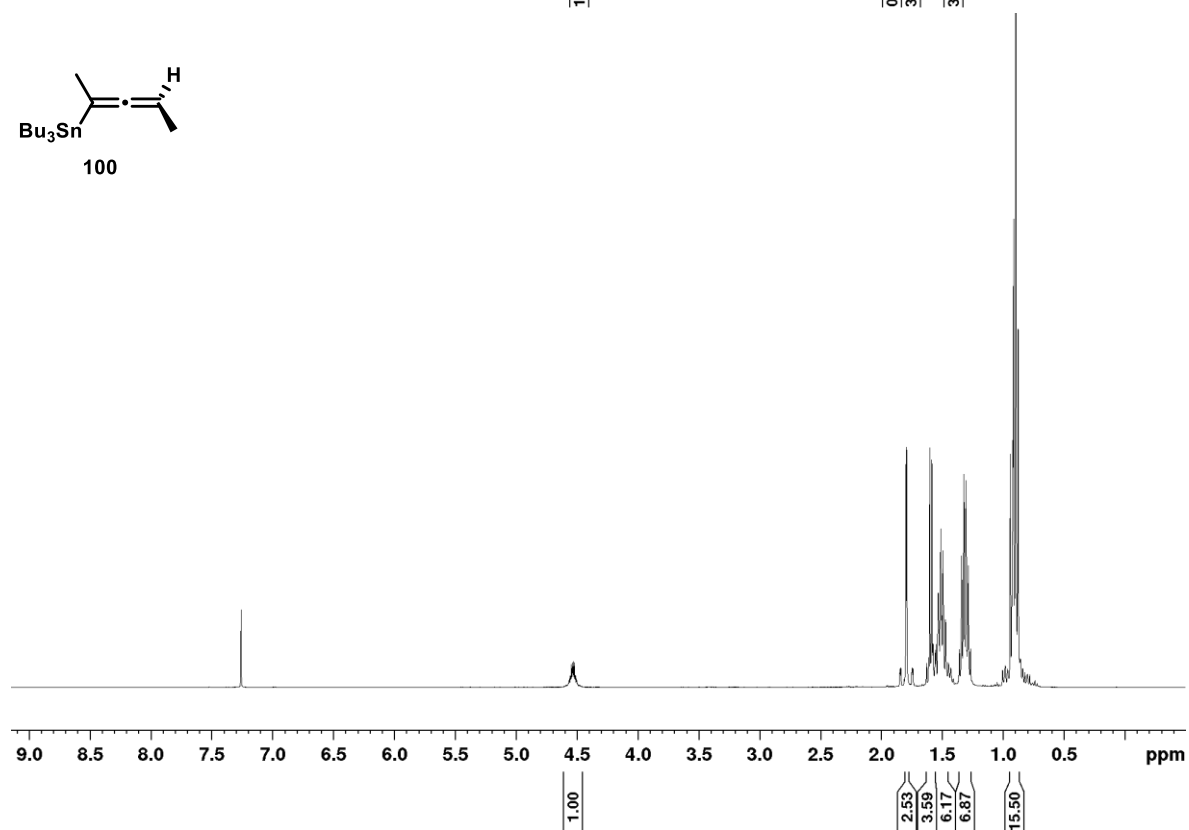

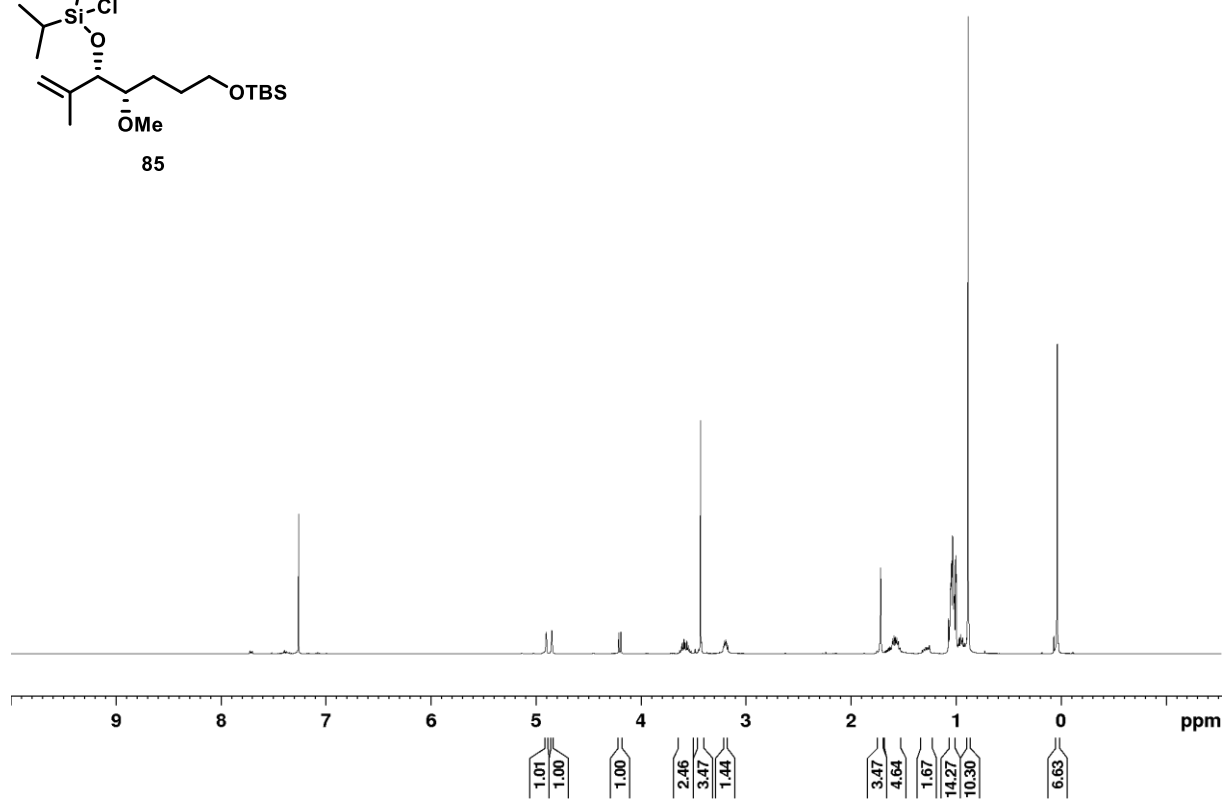
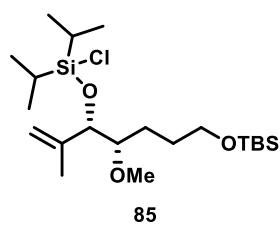
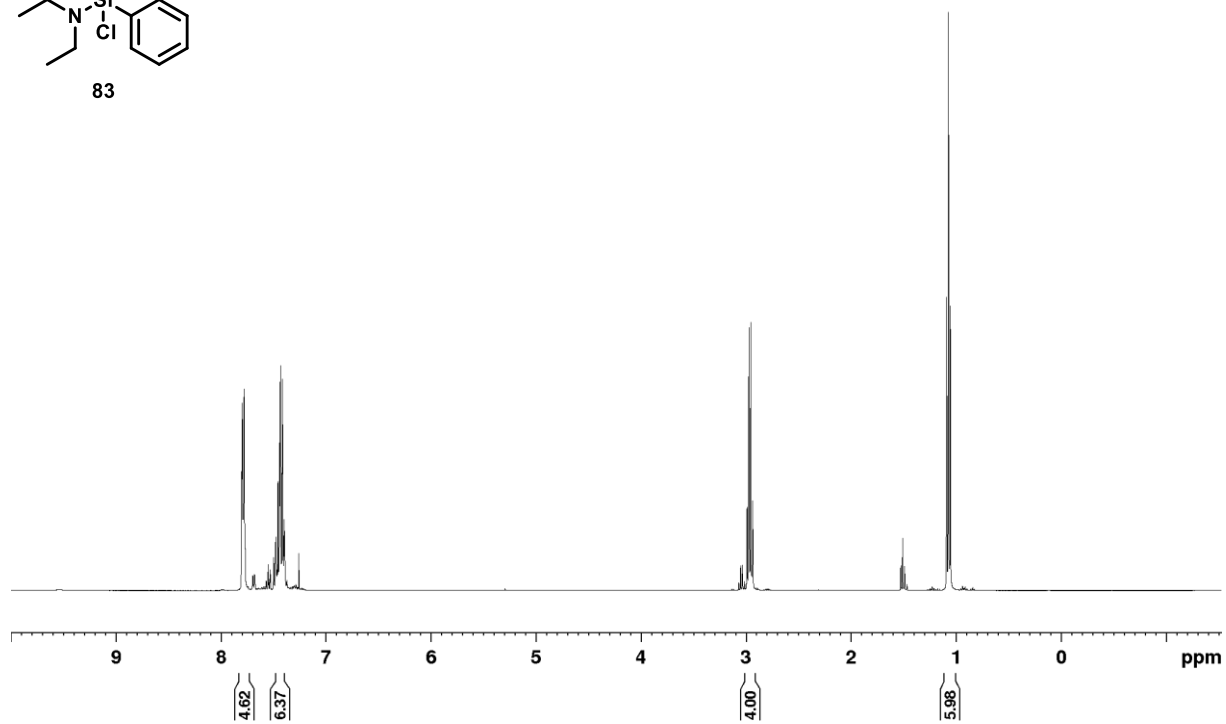
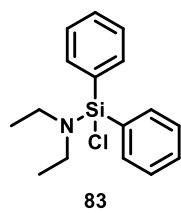

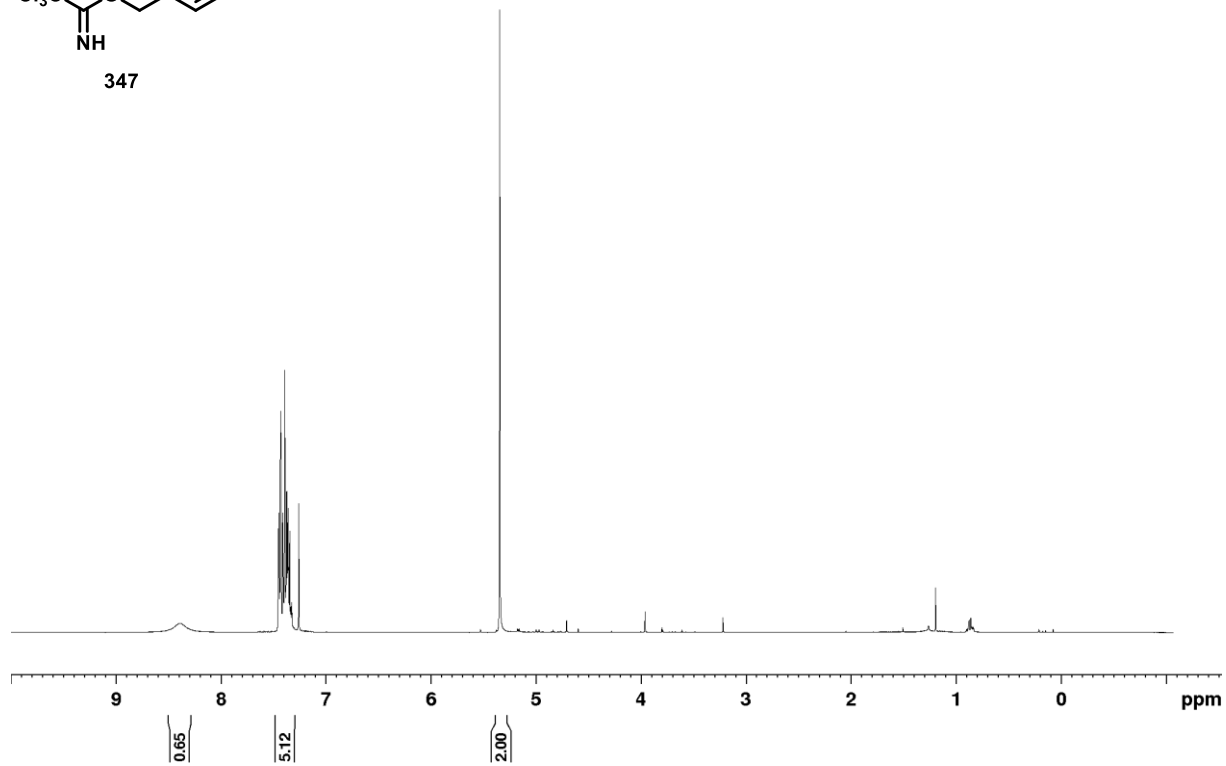
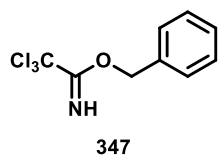
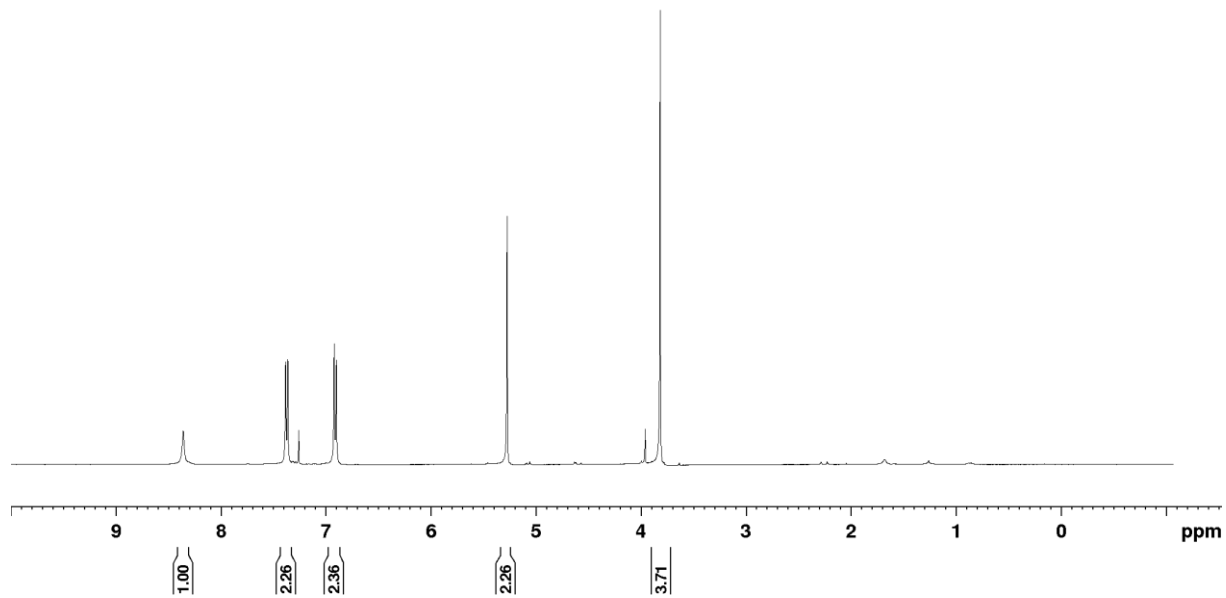
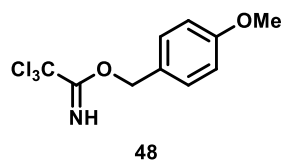

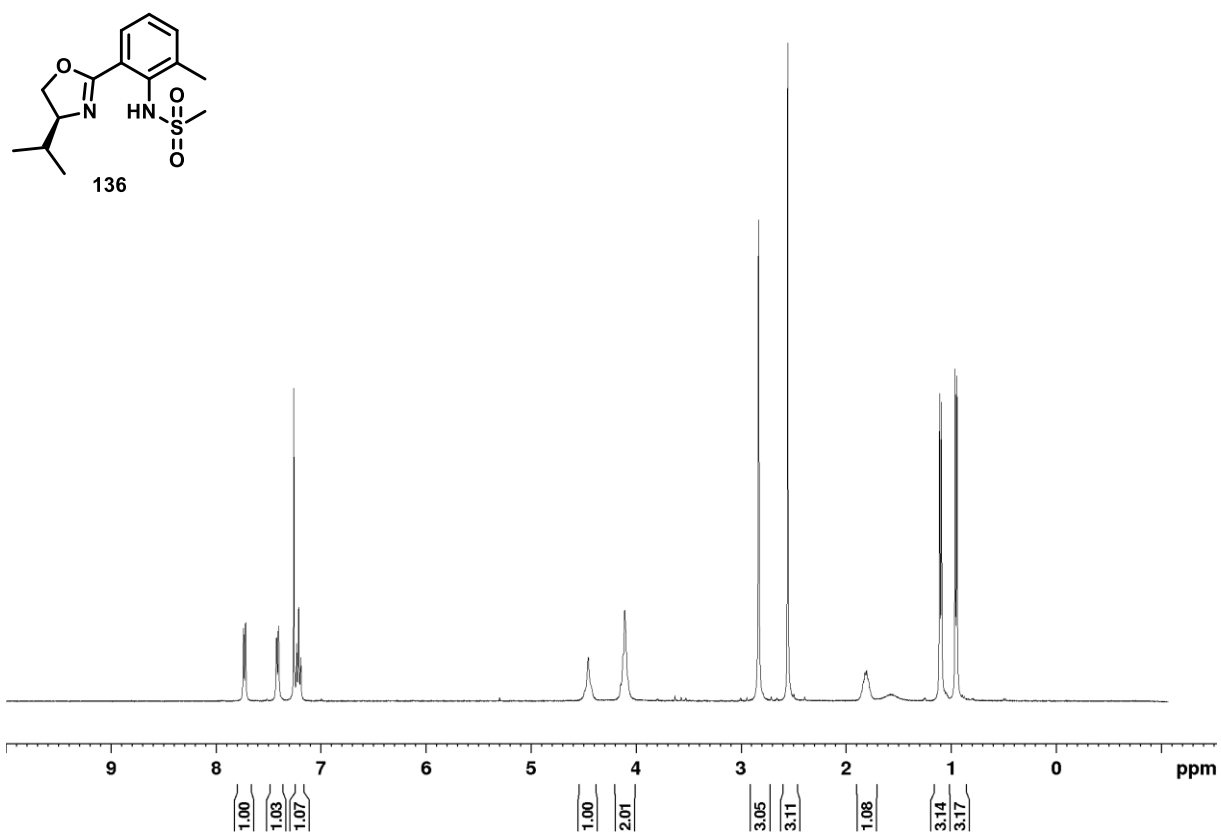
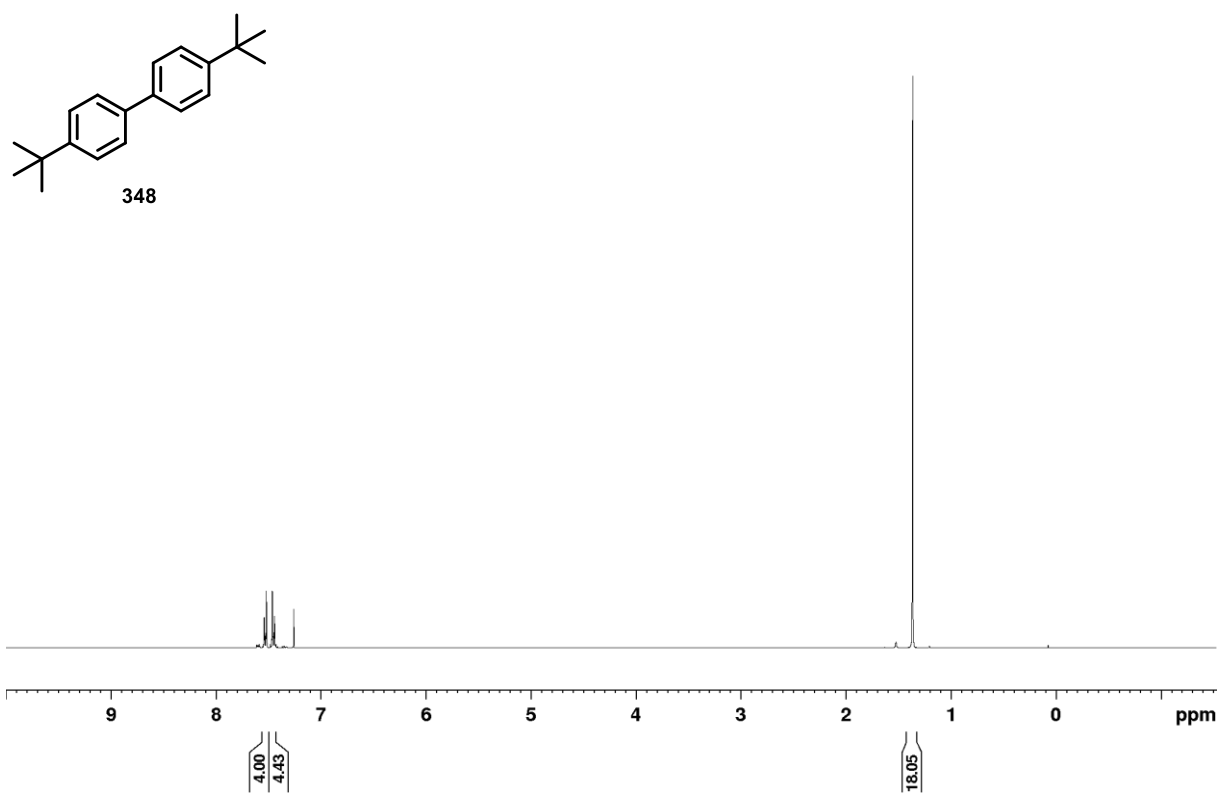

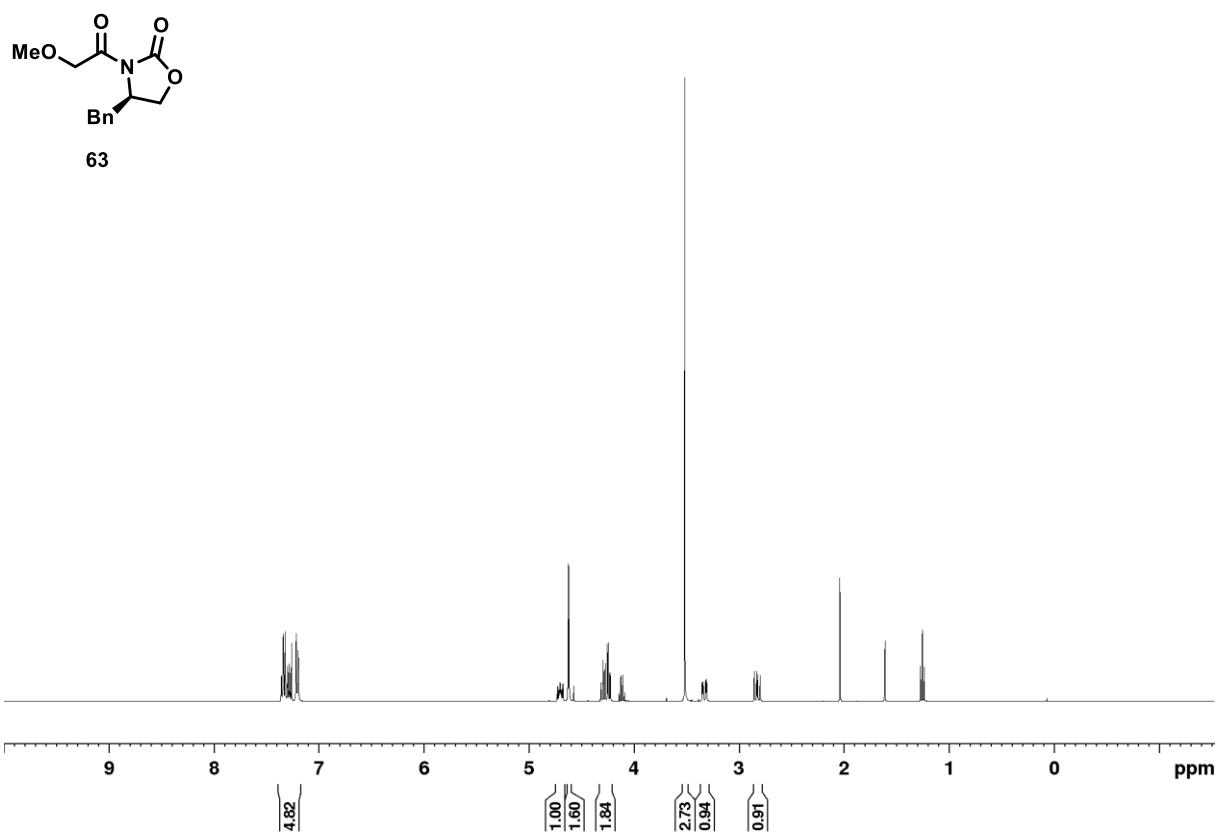
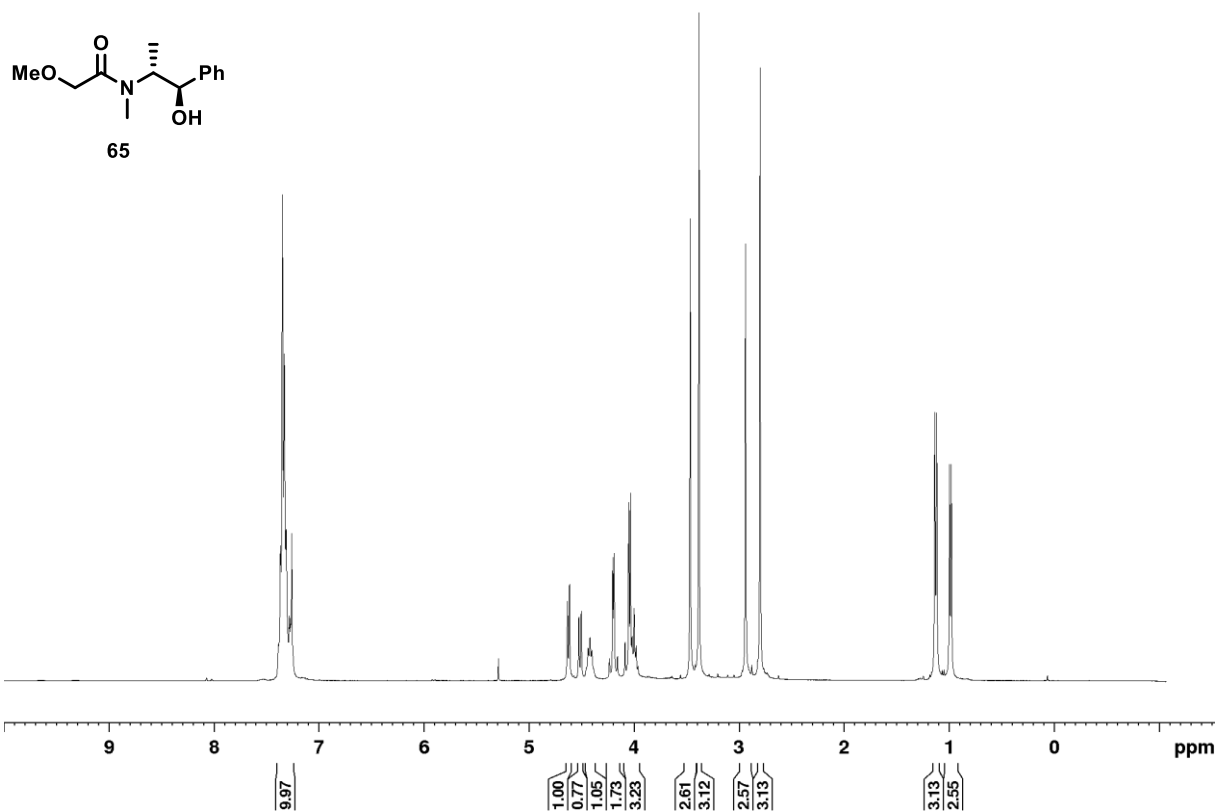



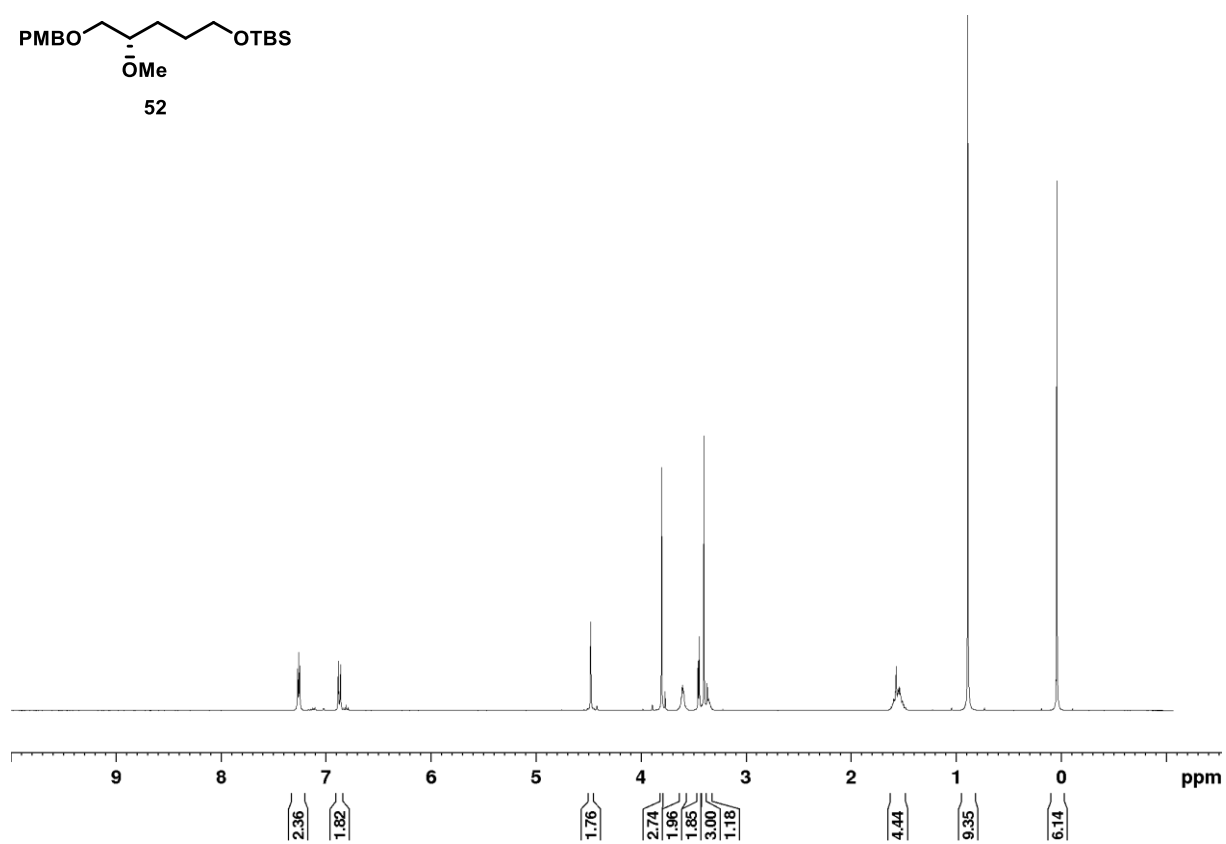
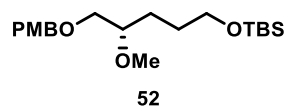
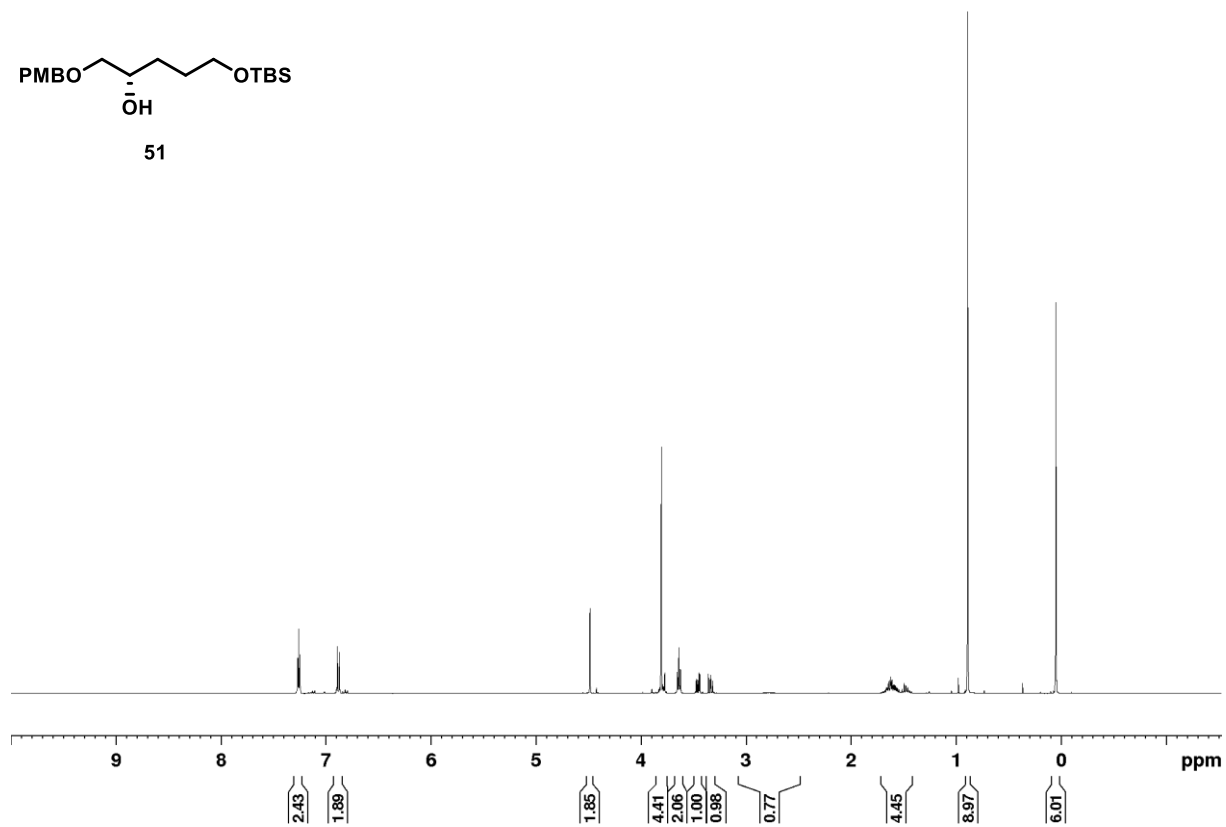
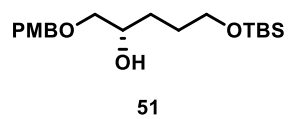

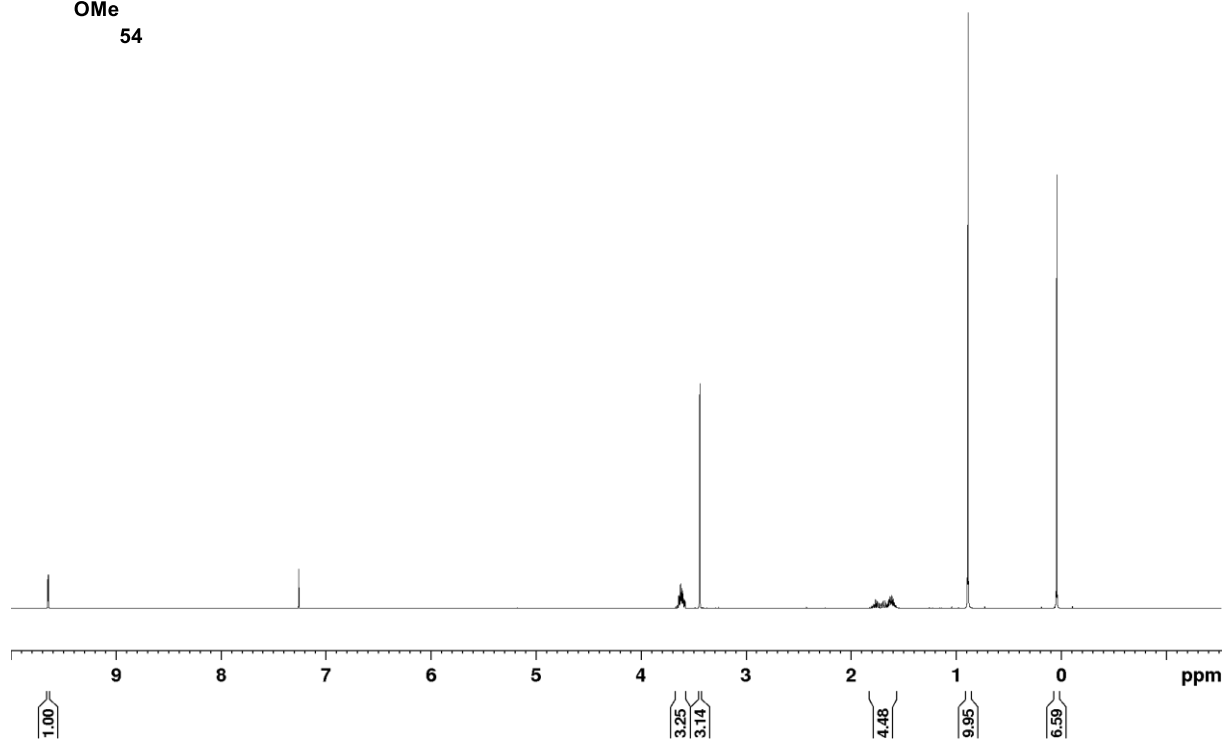
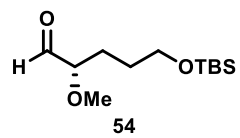
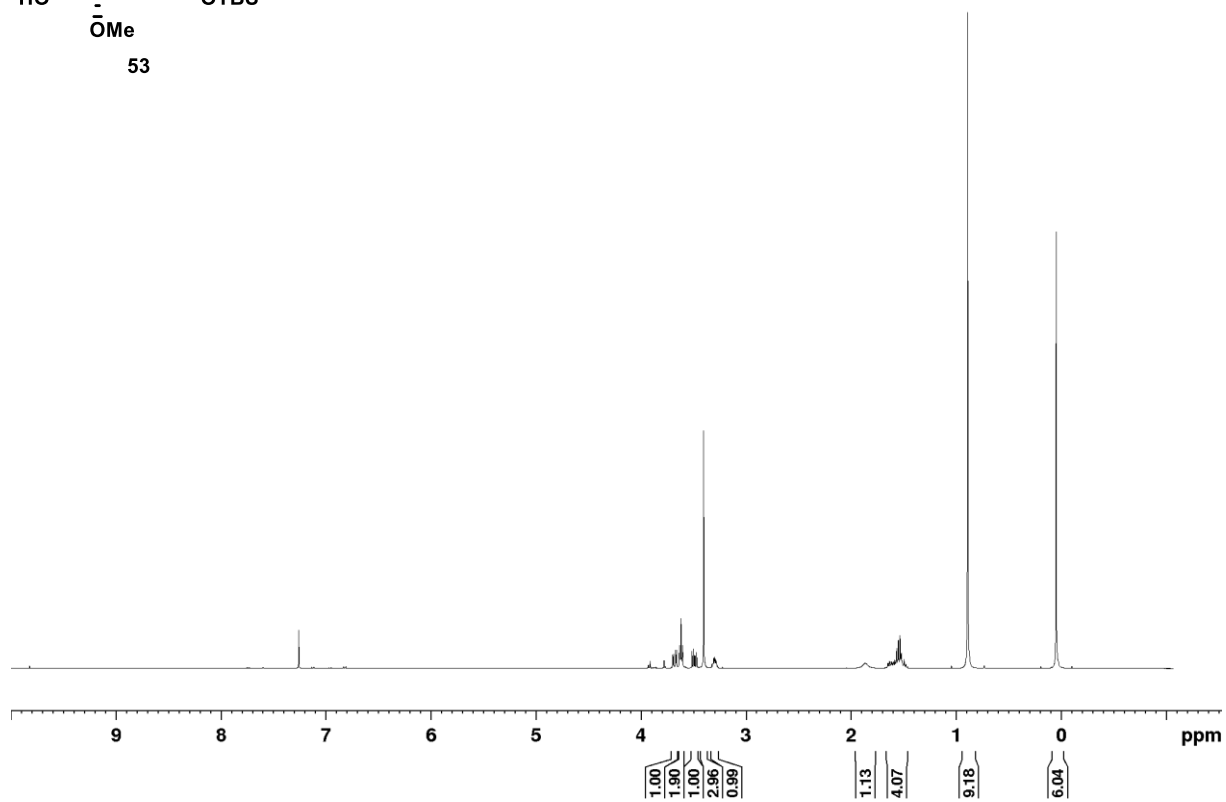
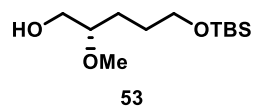

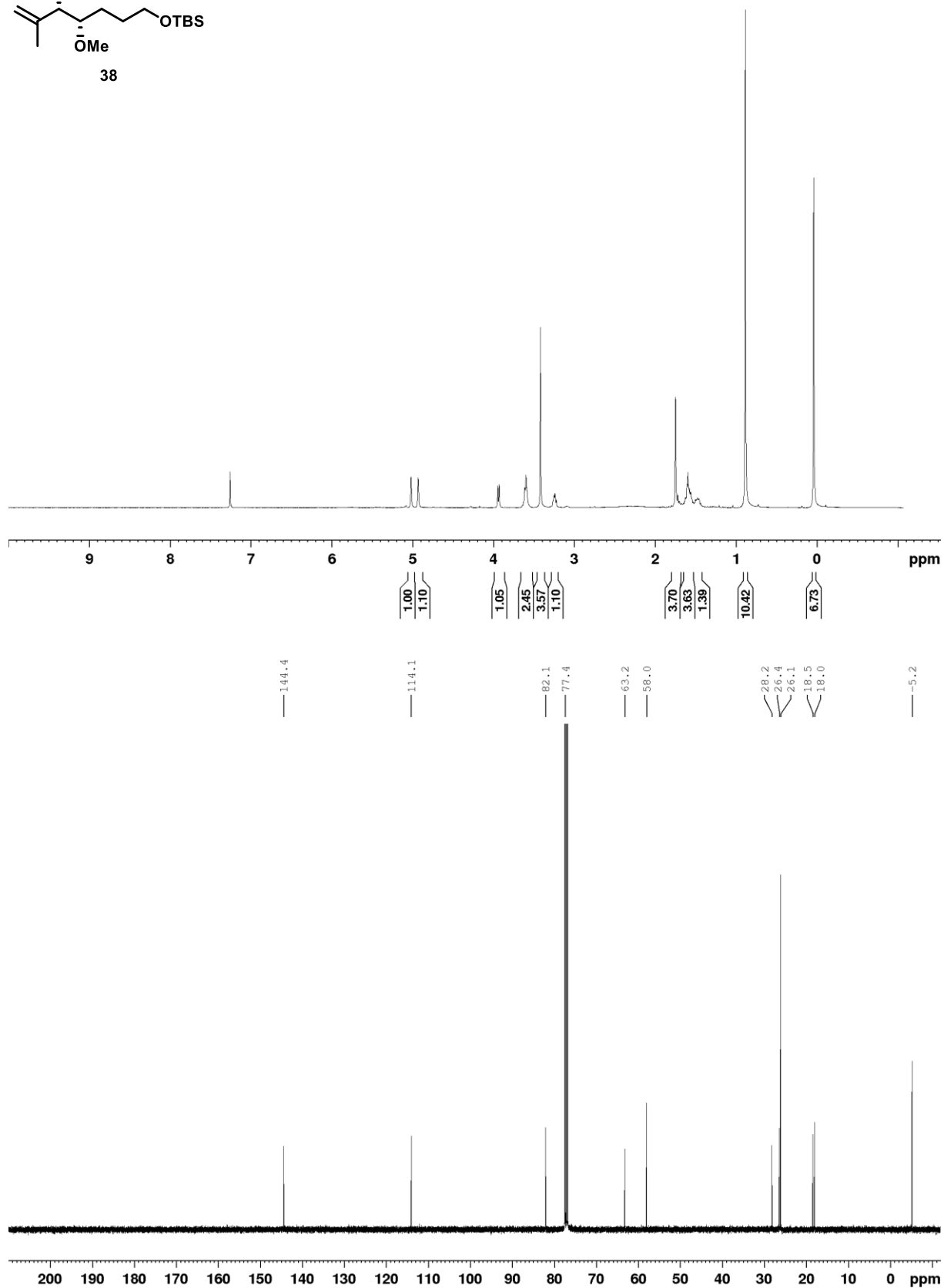
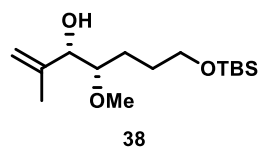

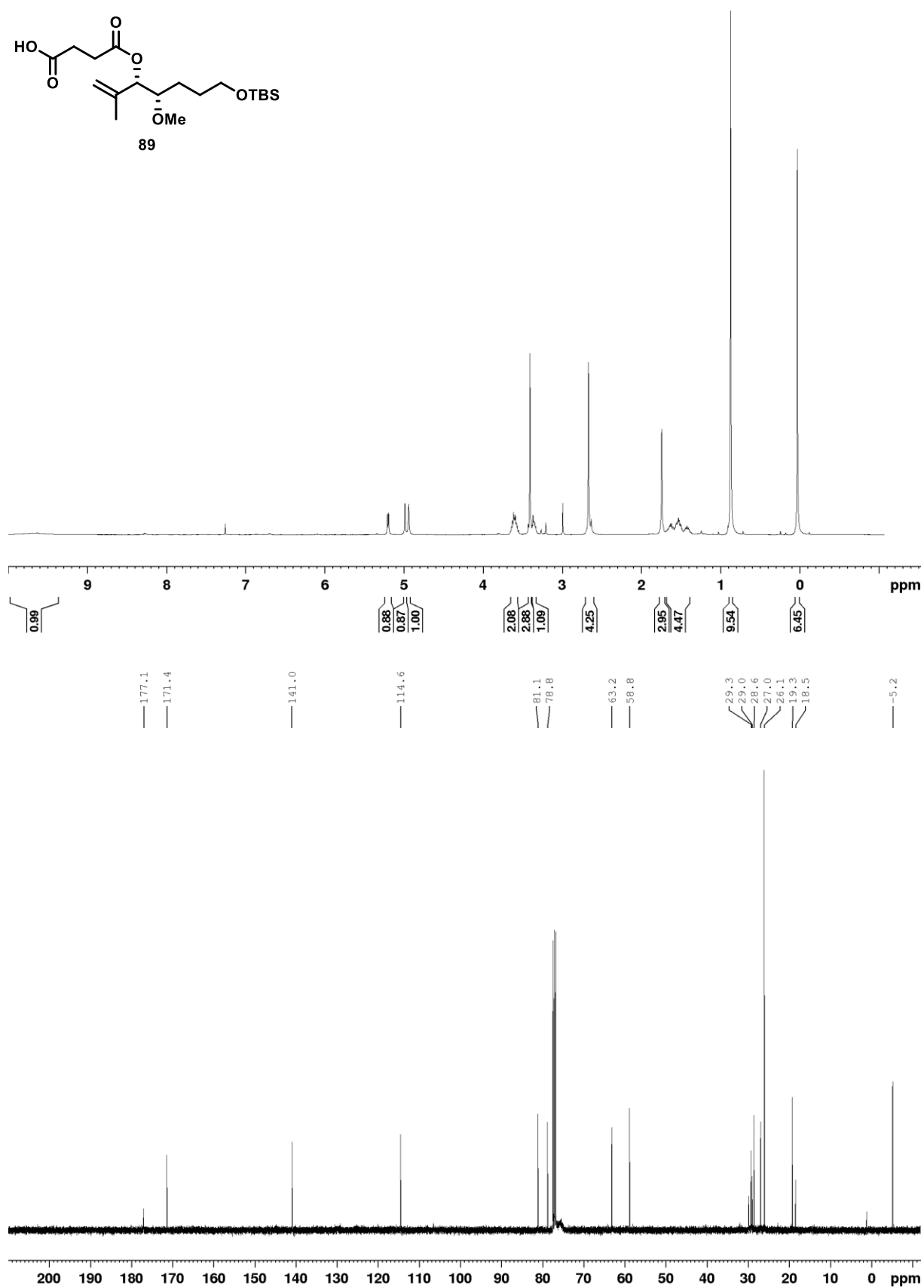
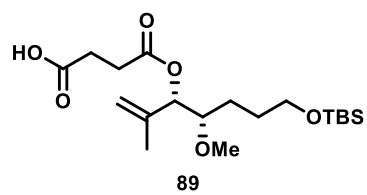

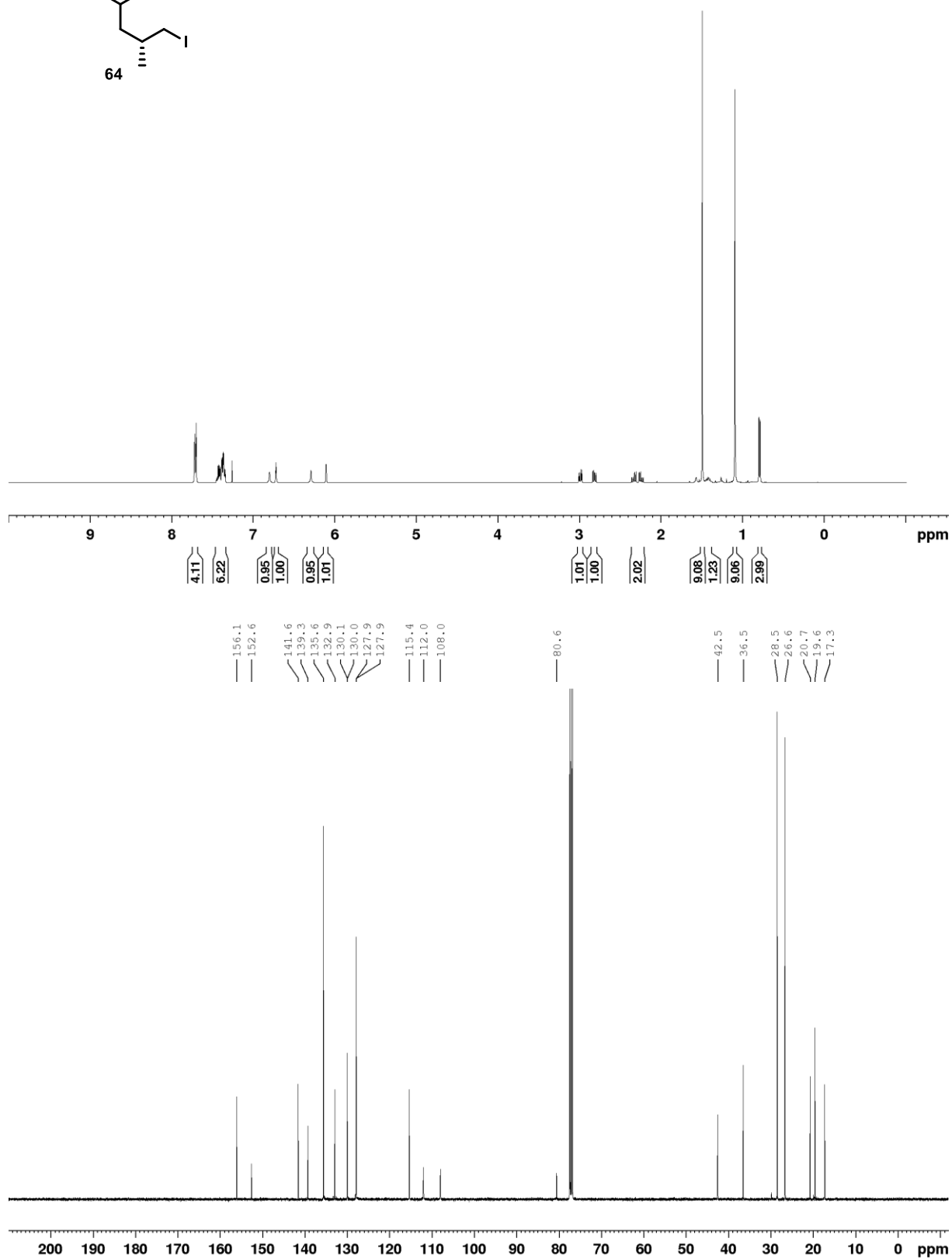
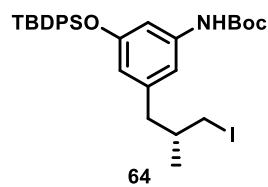

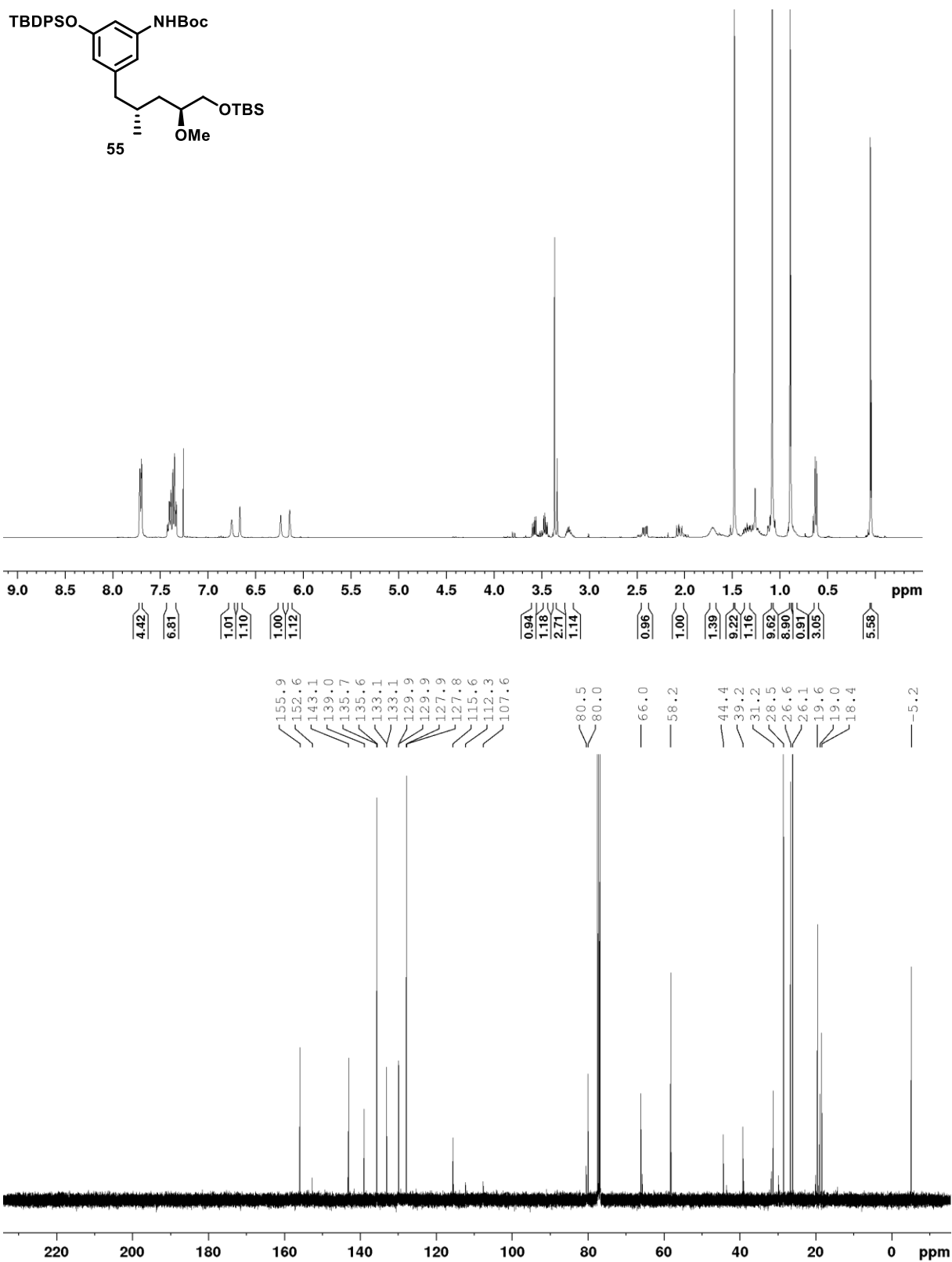

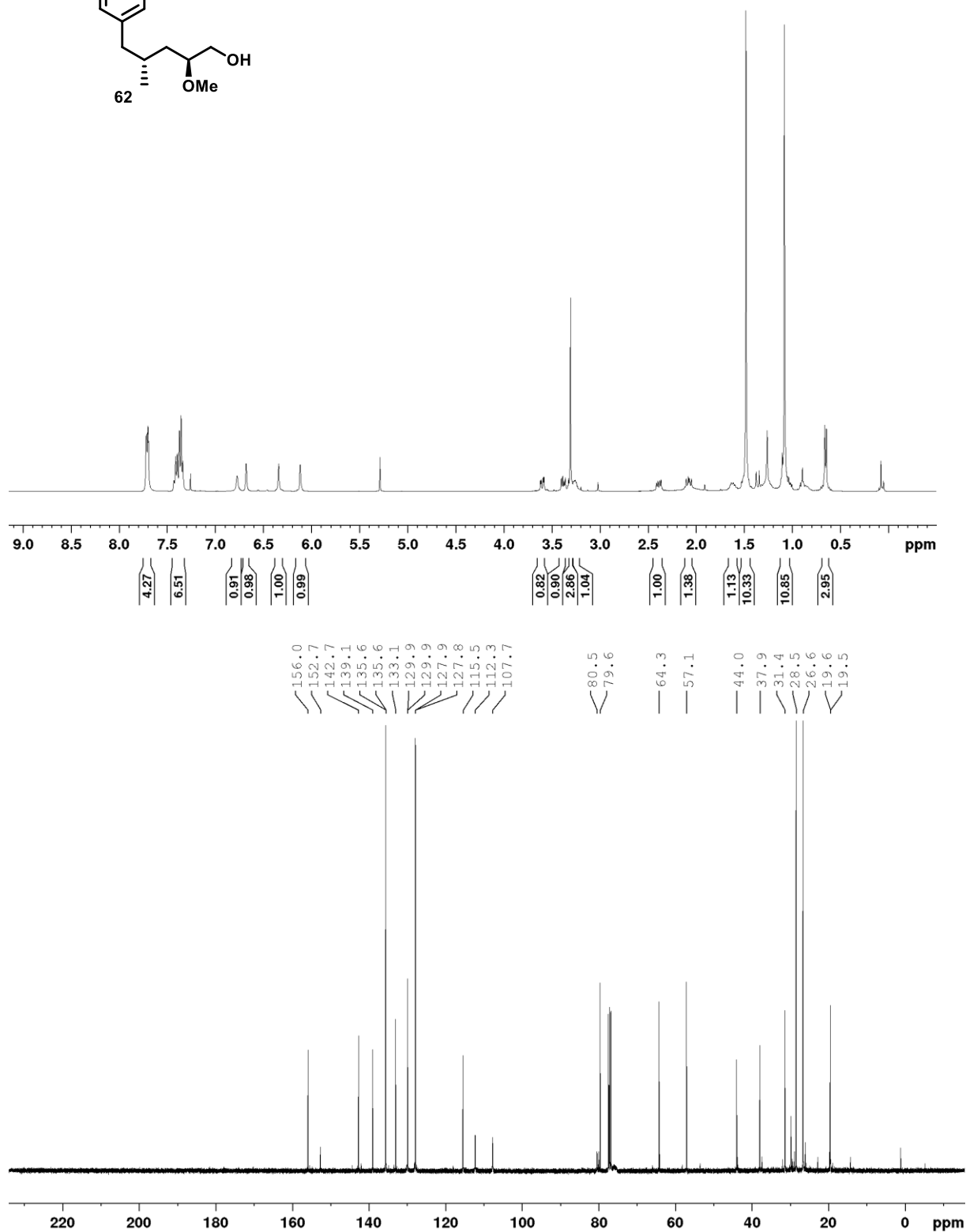
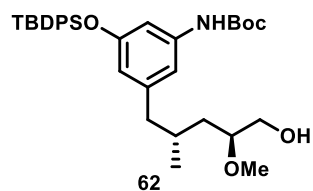

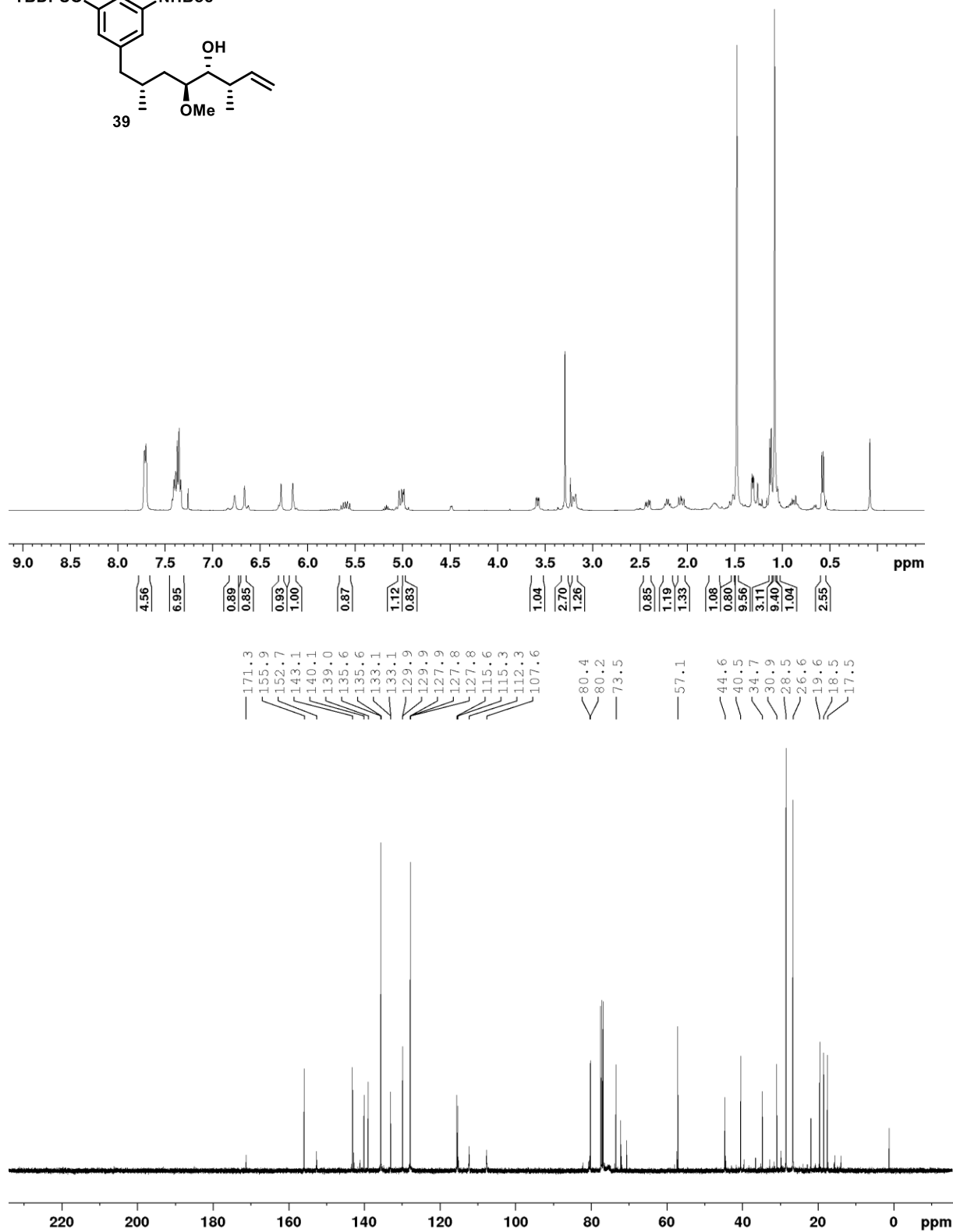
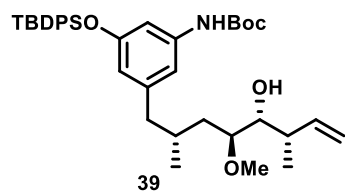



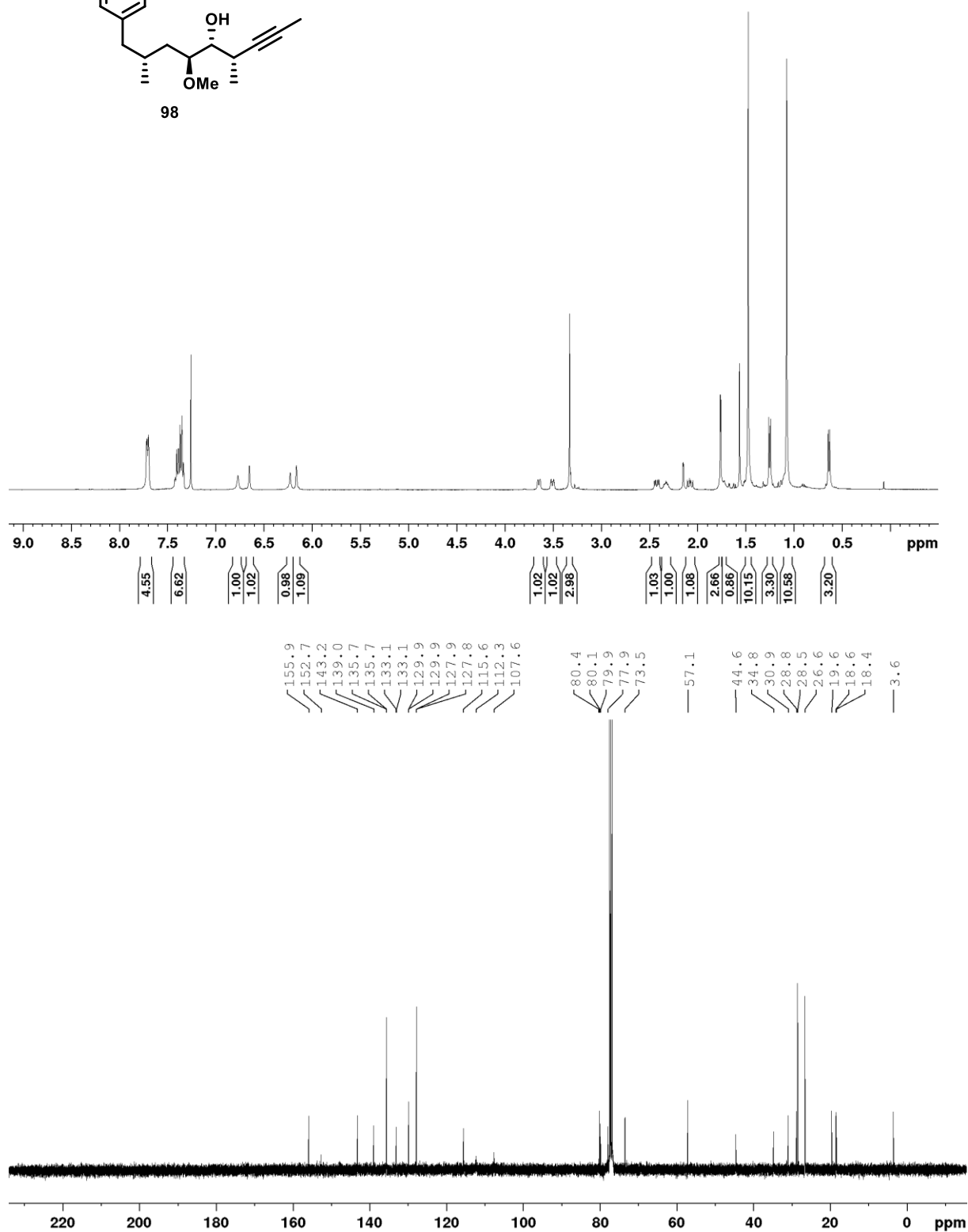
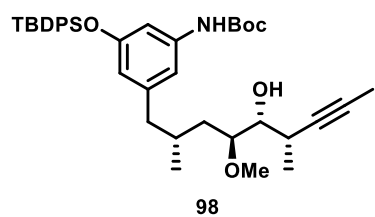



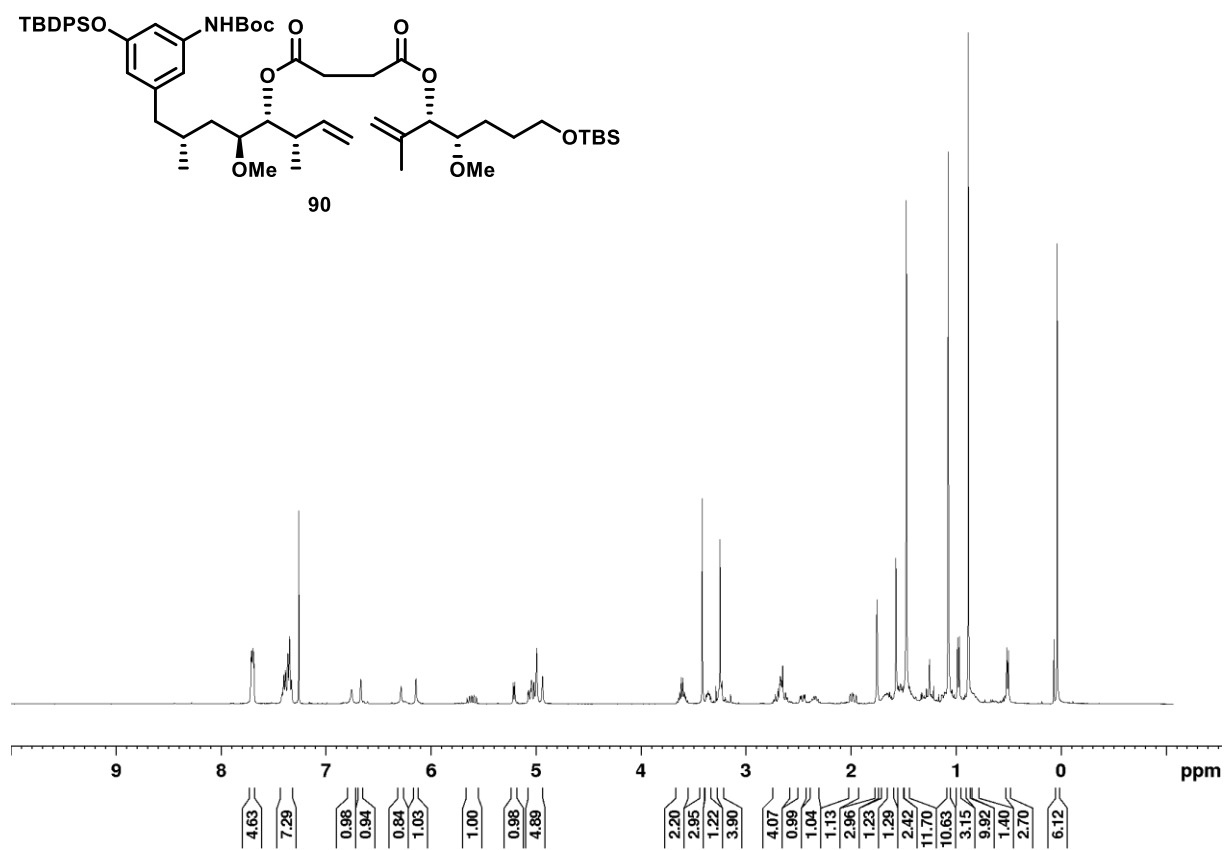
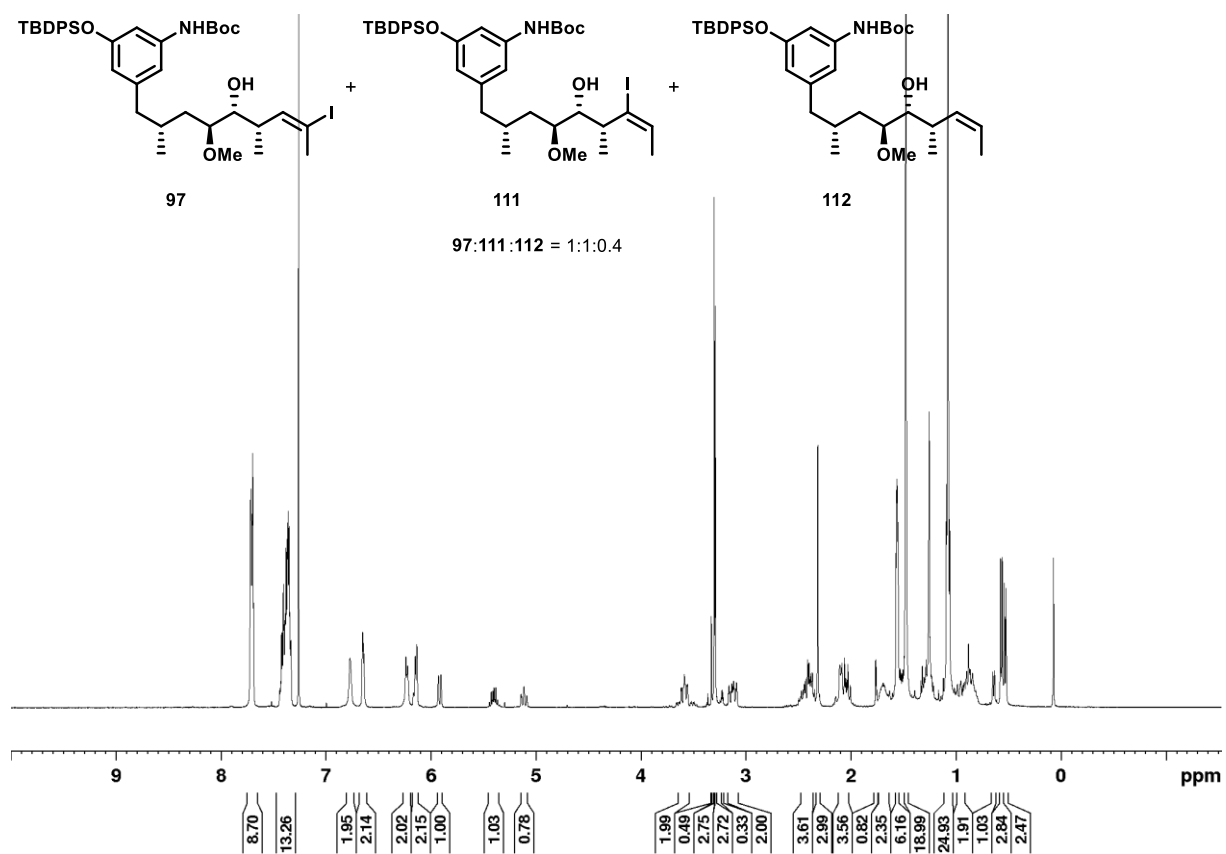

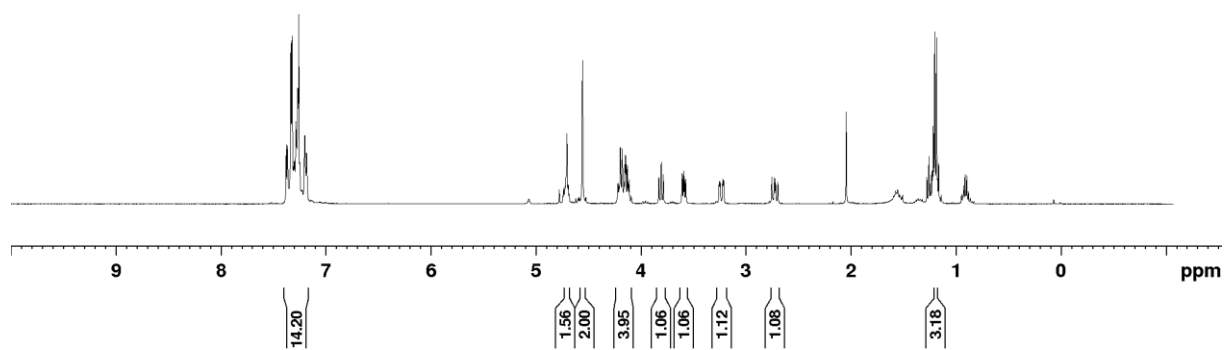
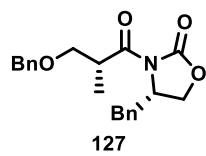
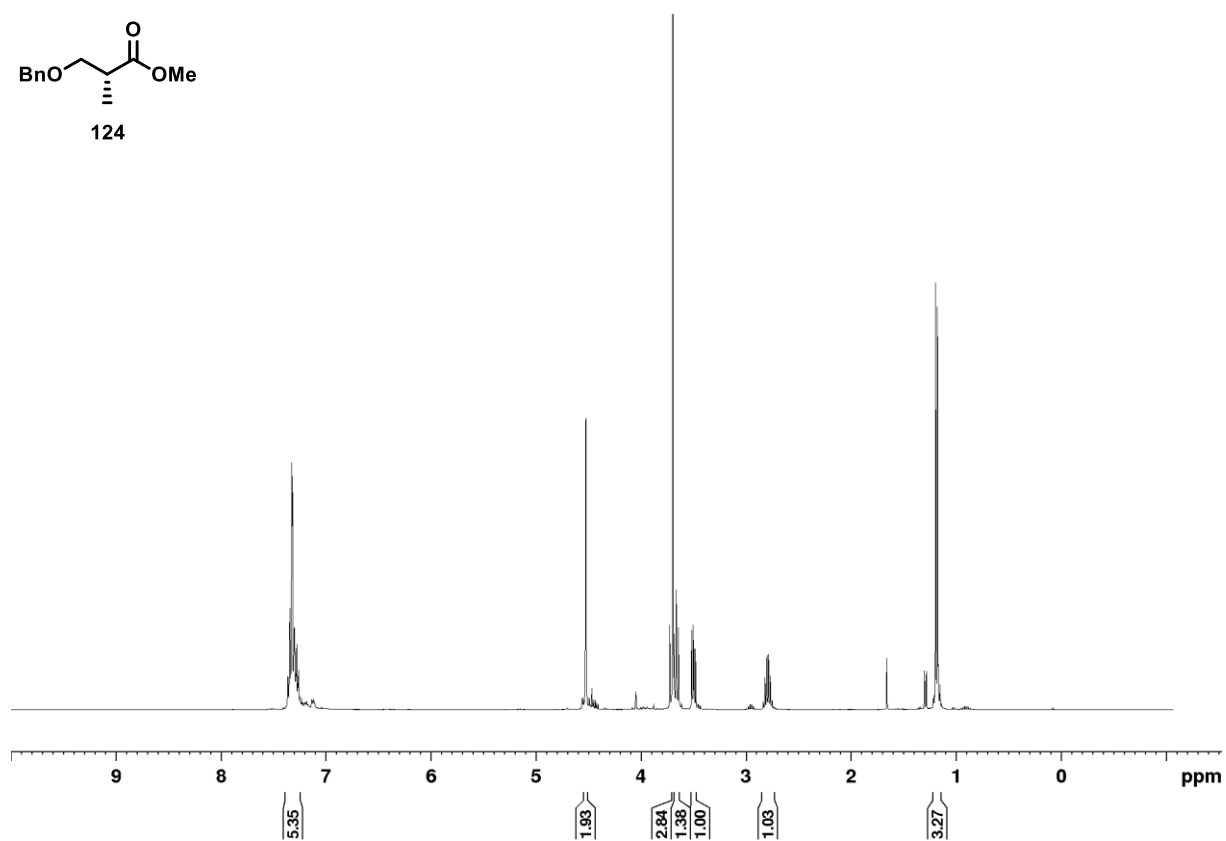
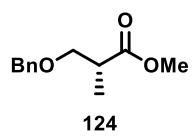

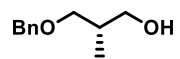

125

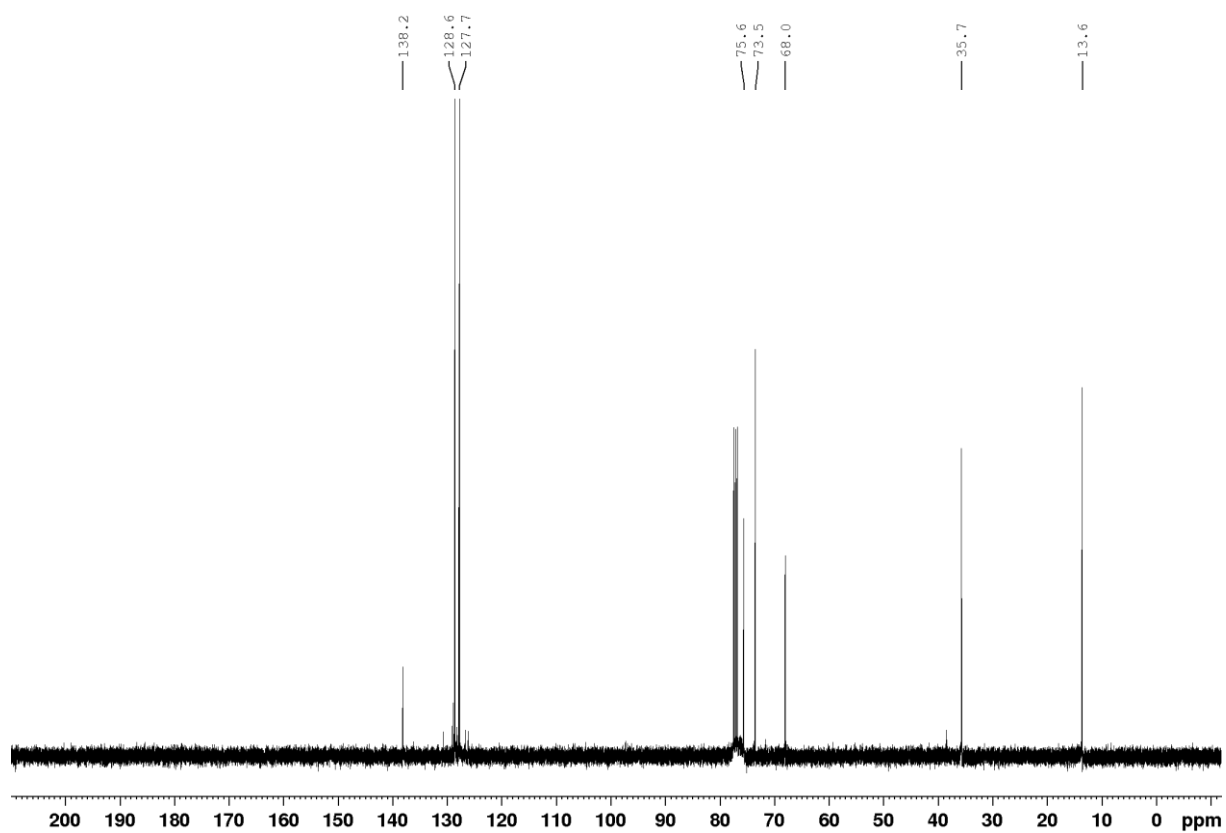
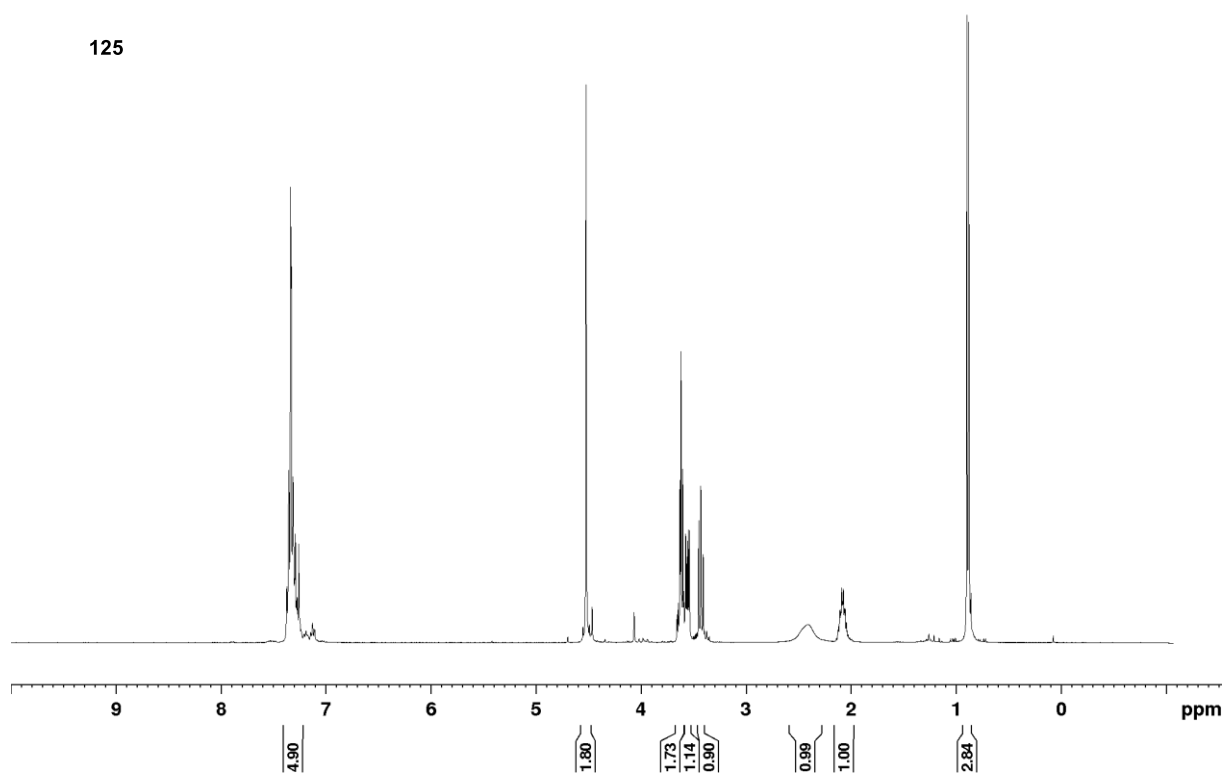

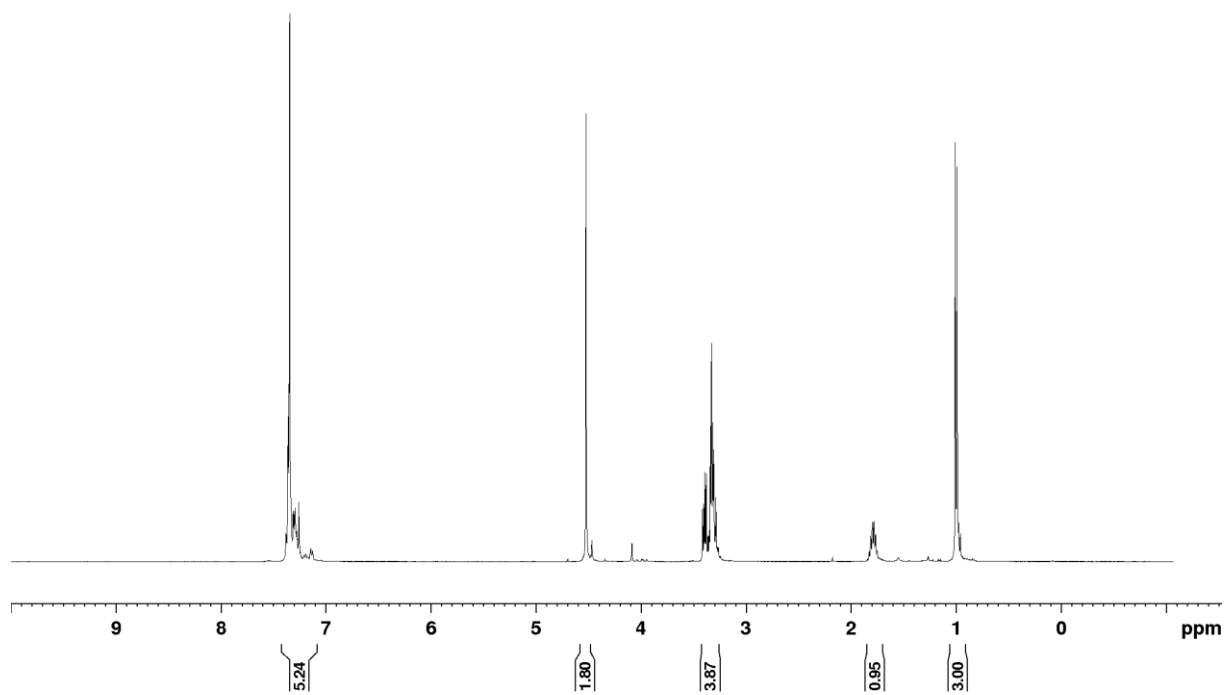
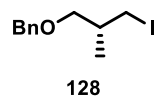

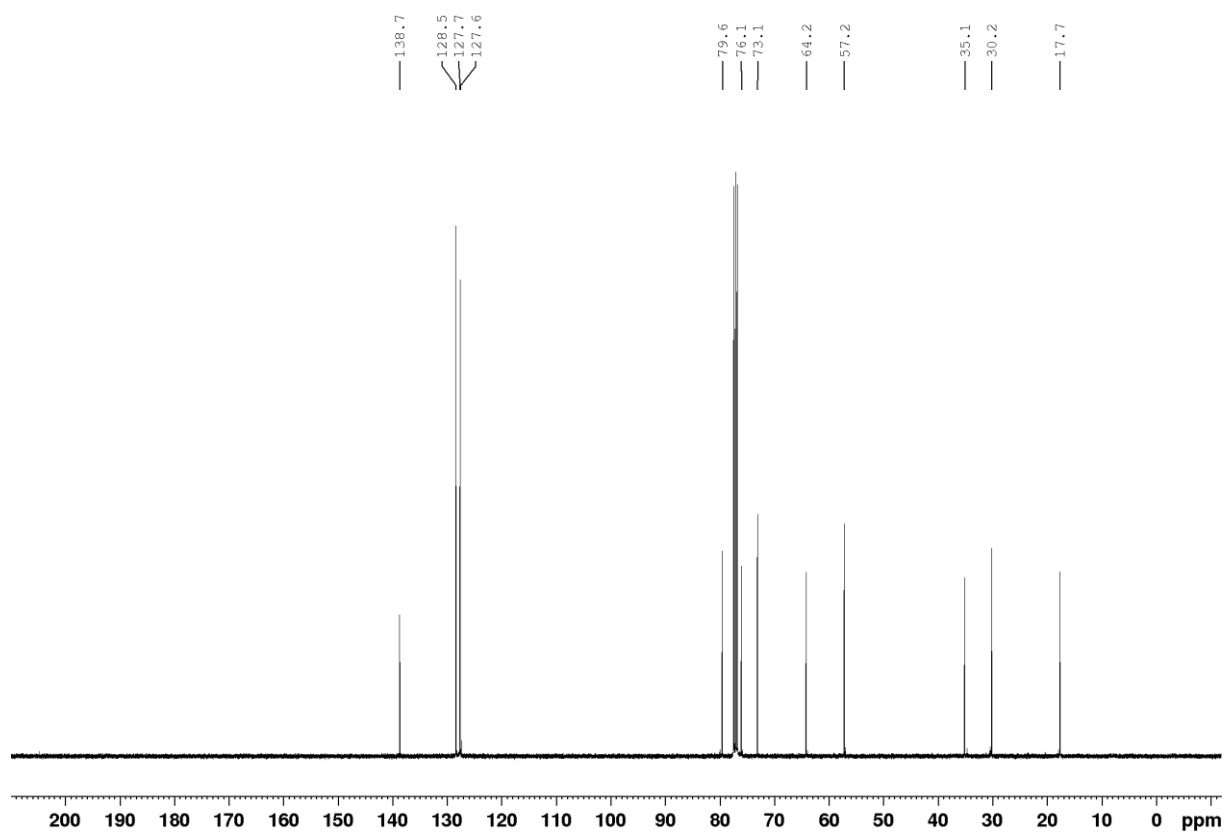
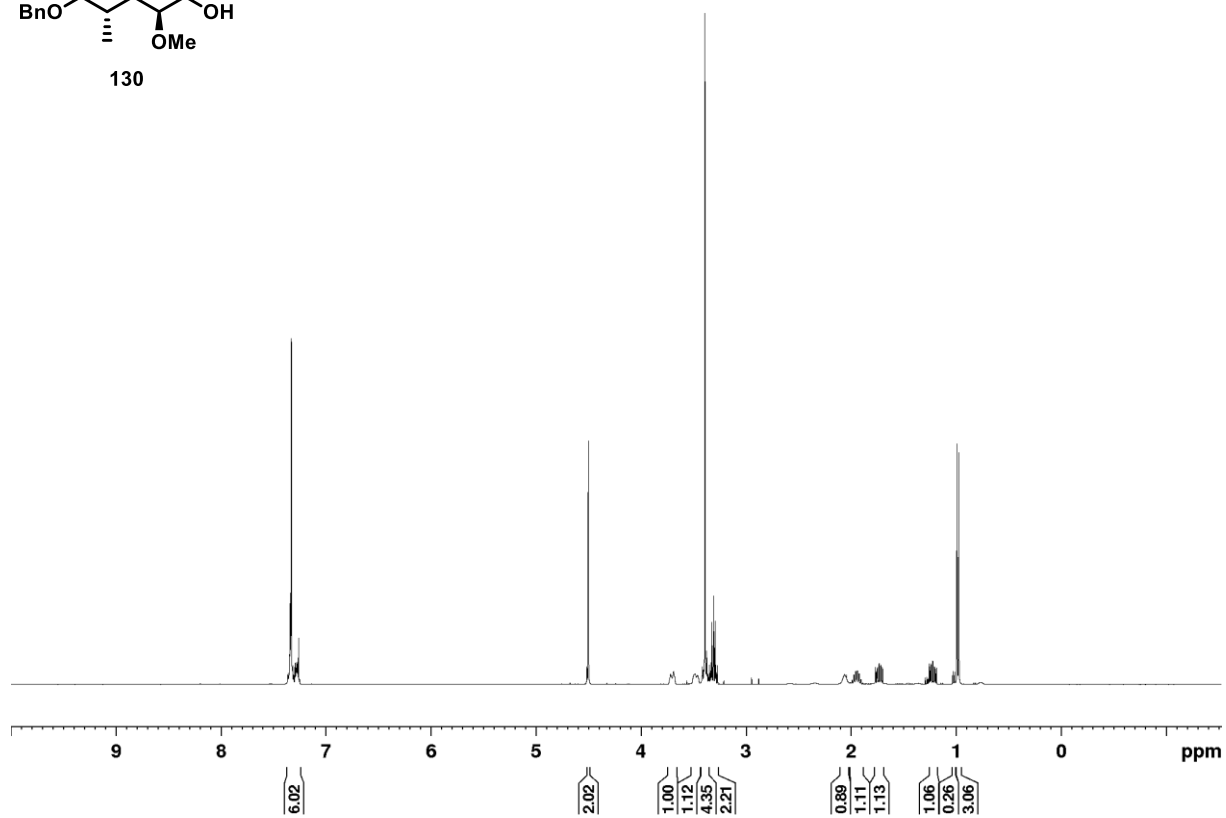
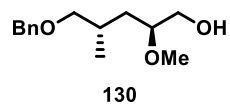

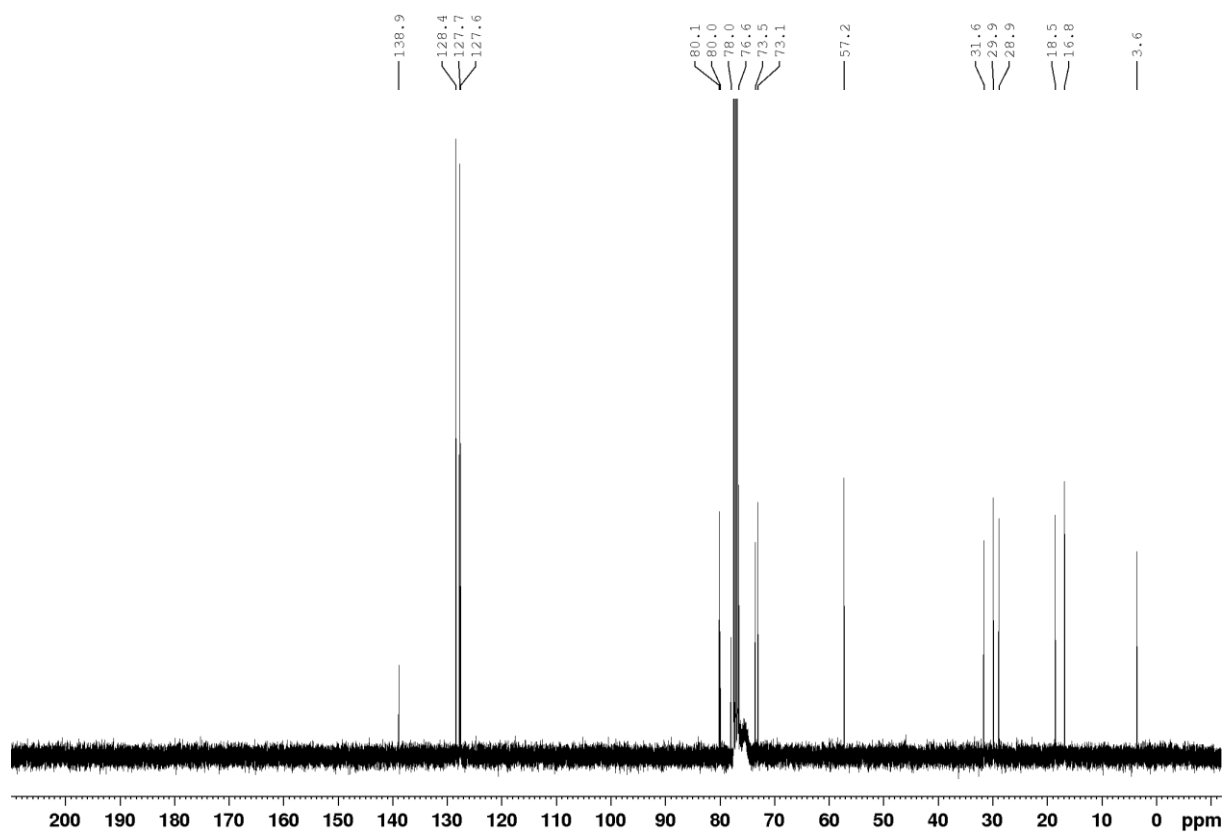
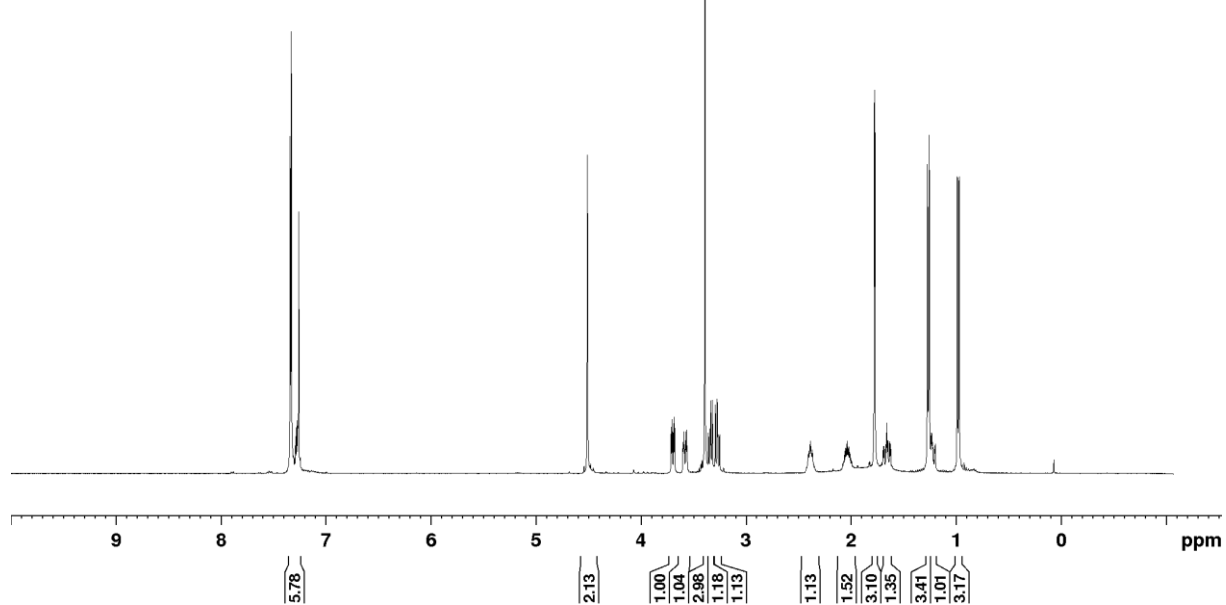
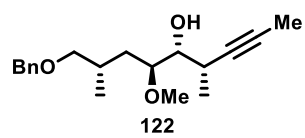



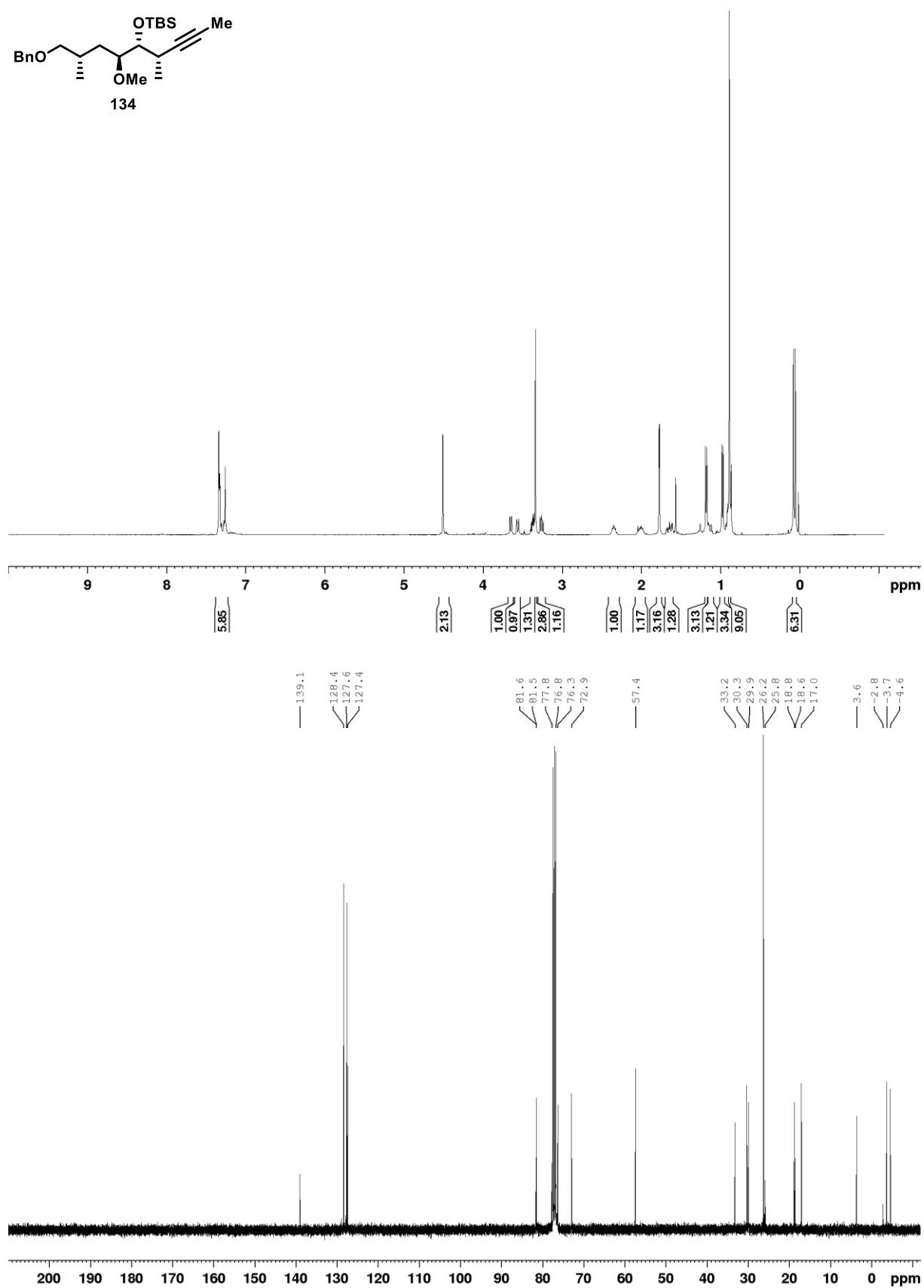
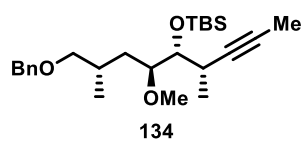

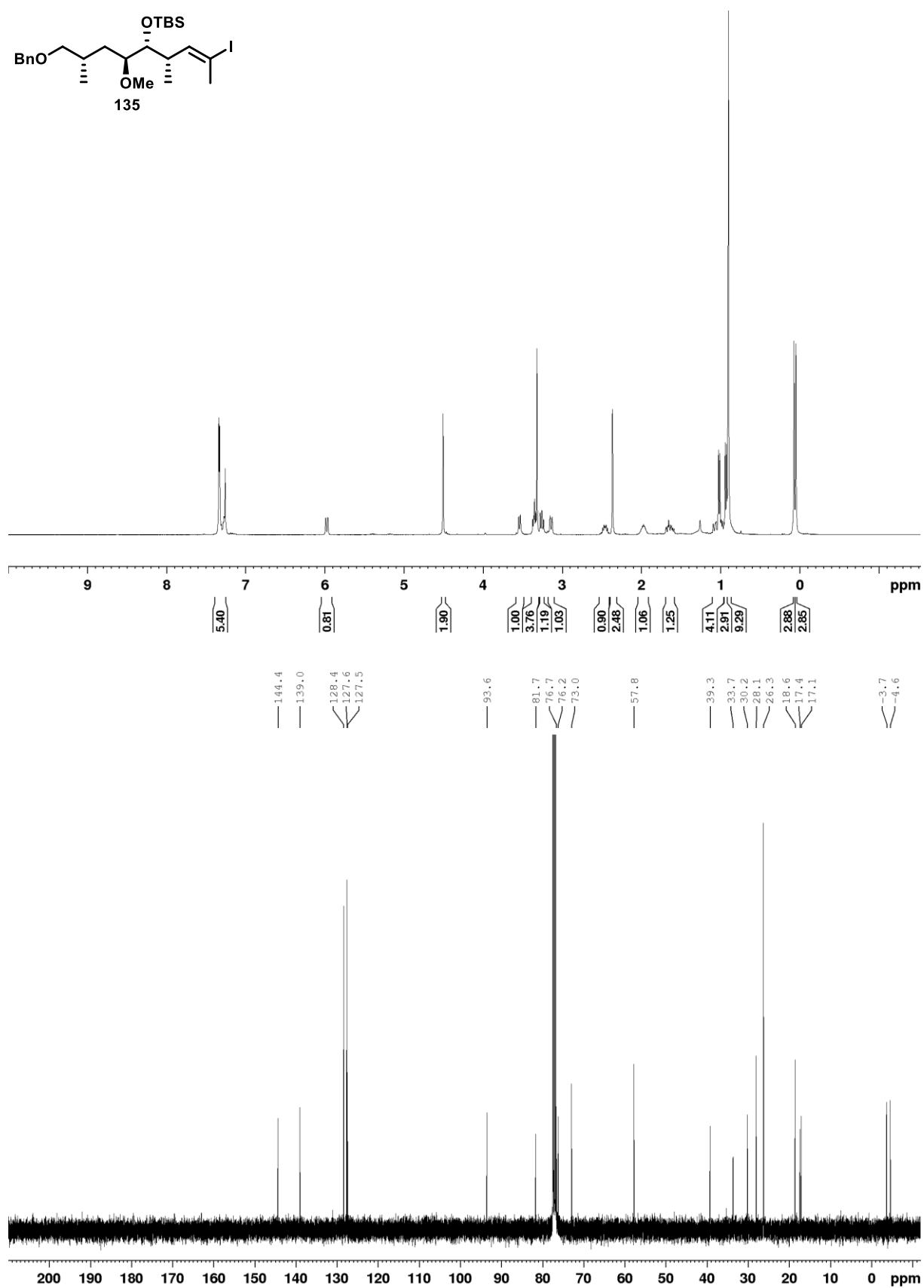
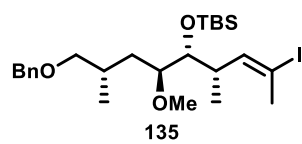

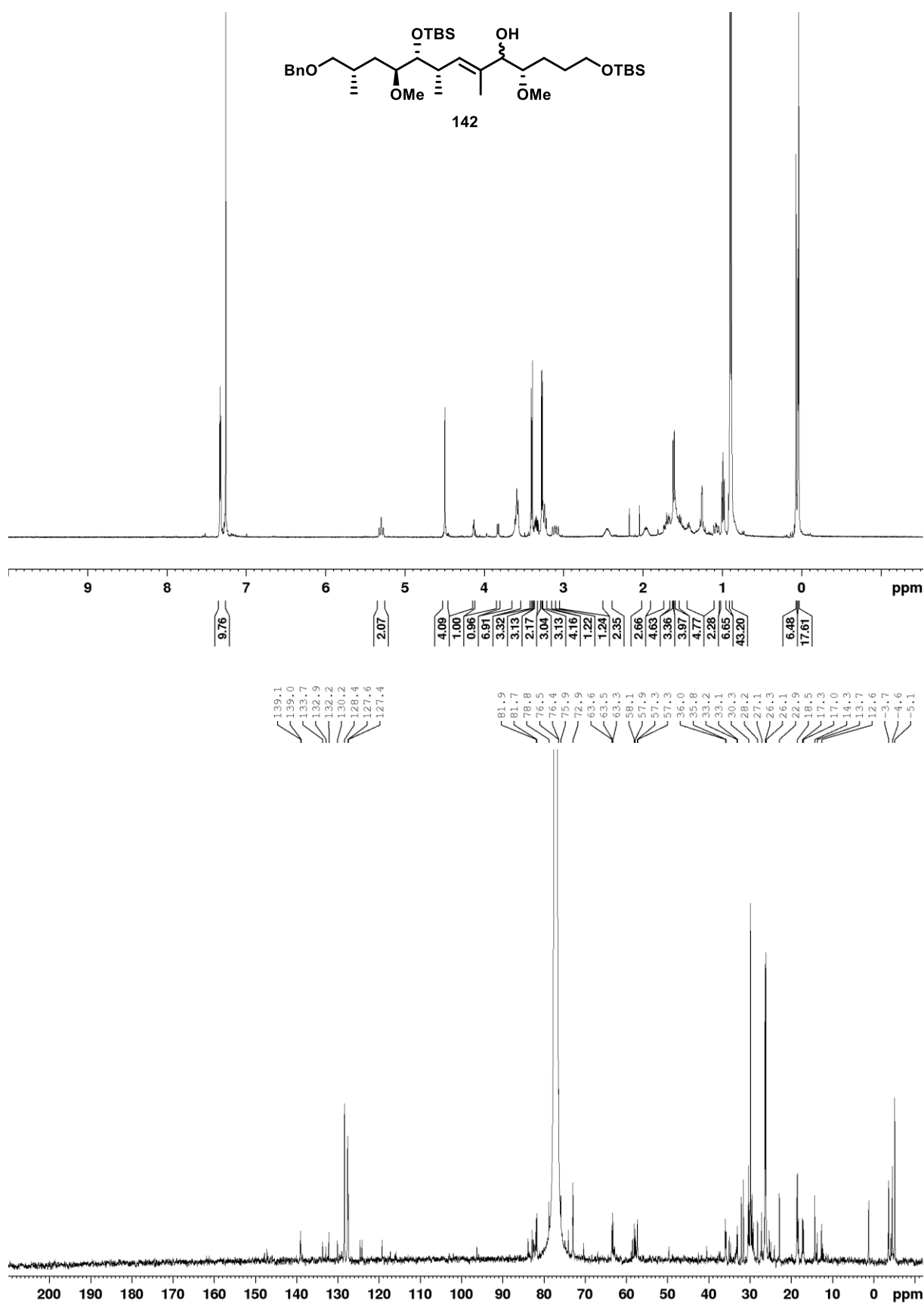

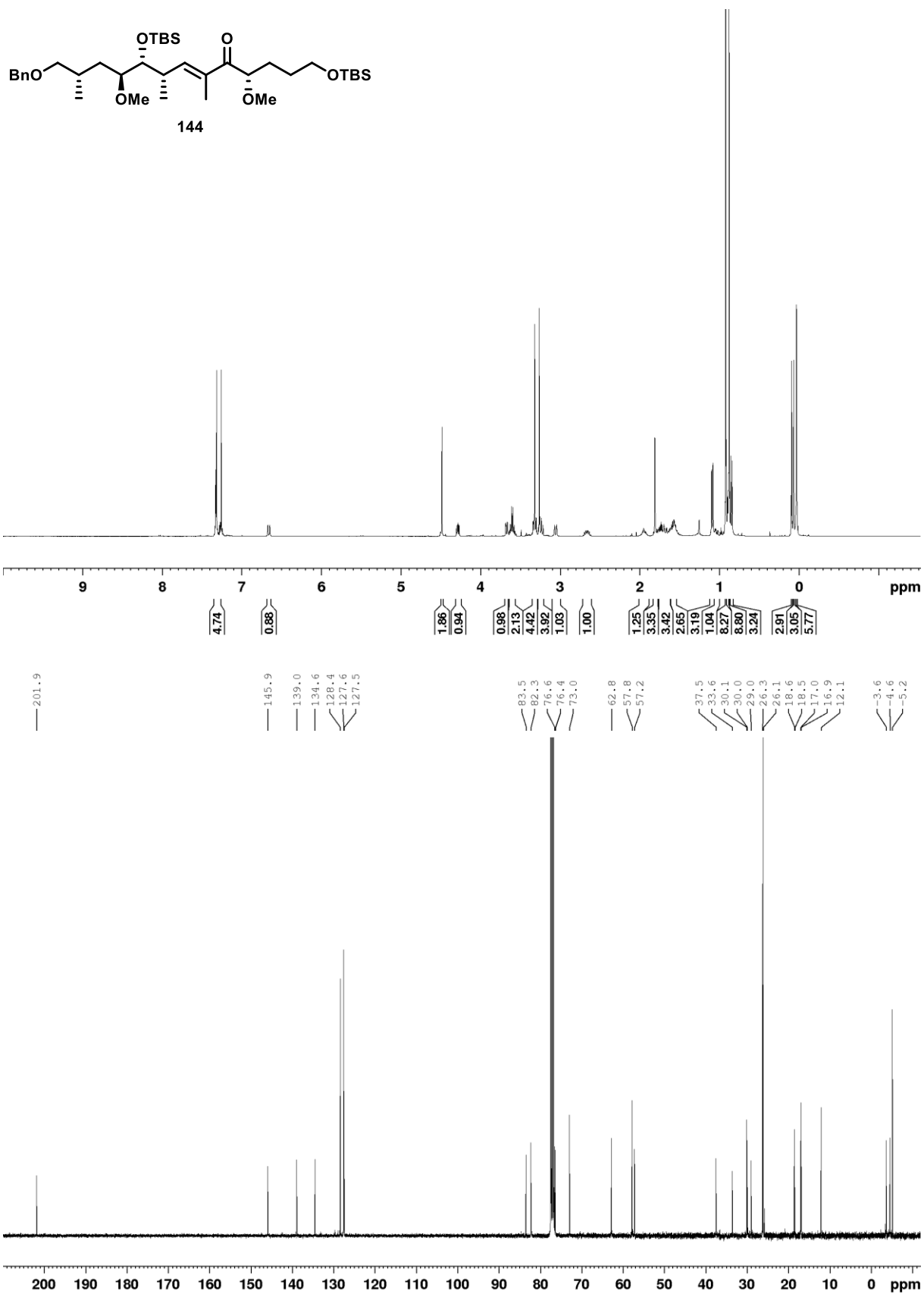

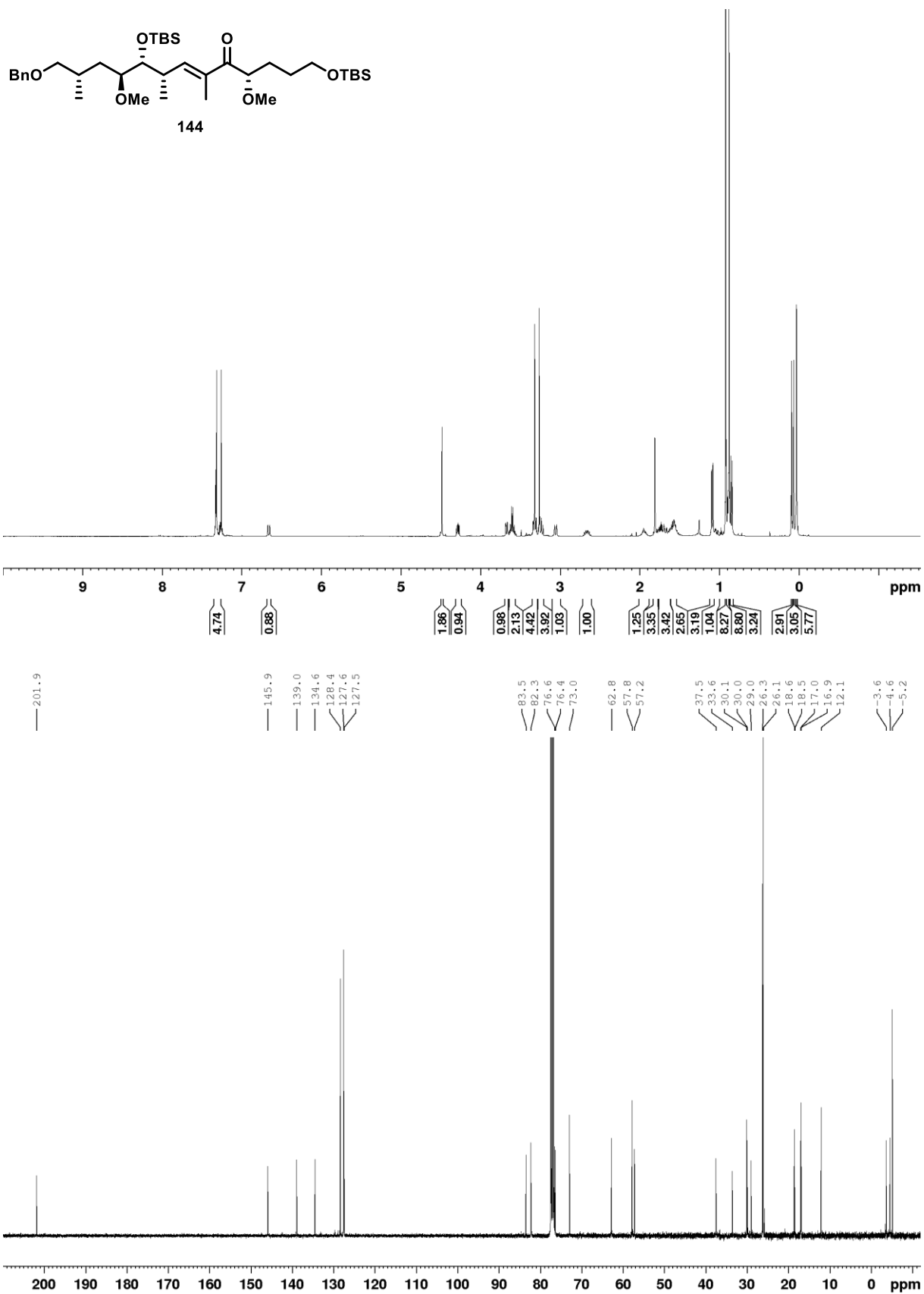

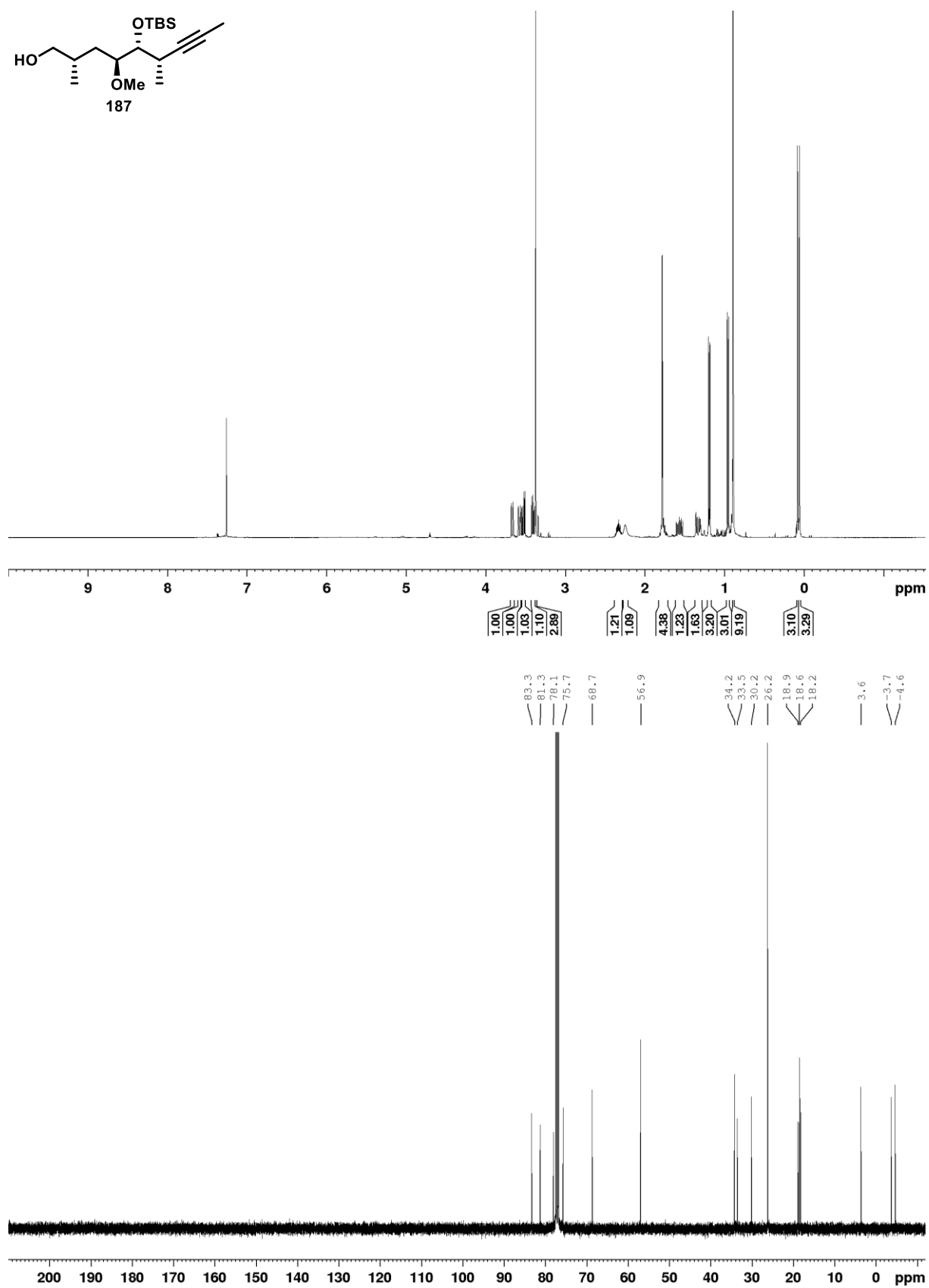

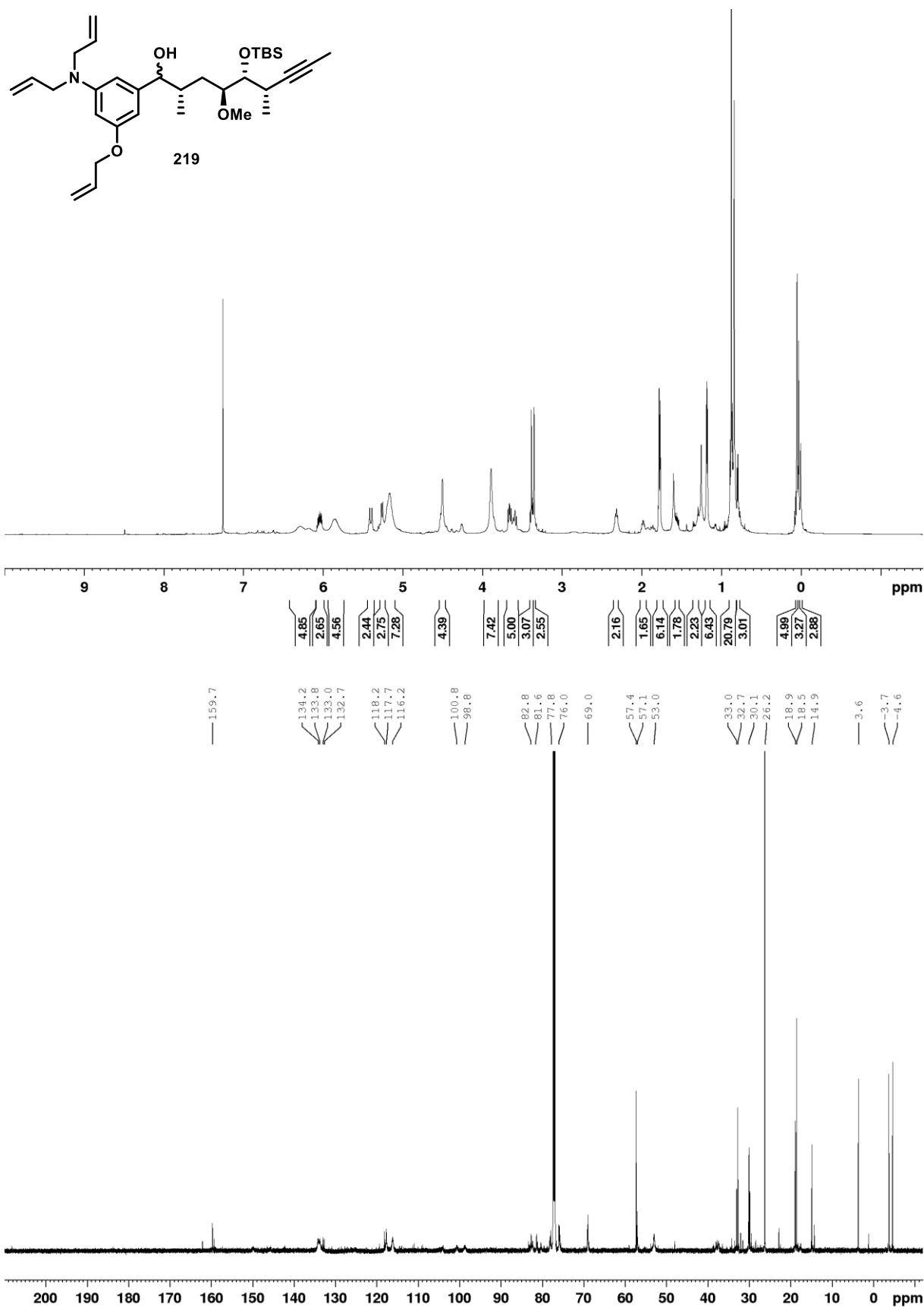

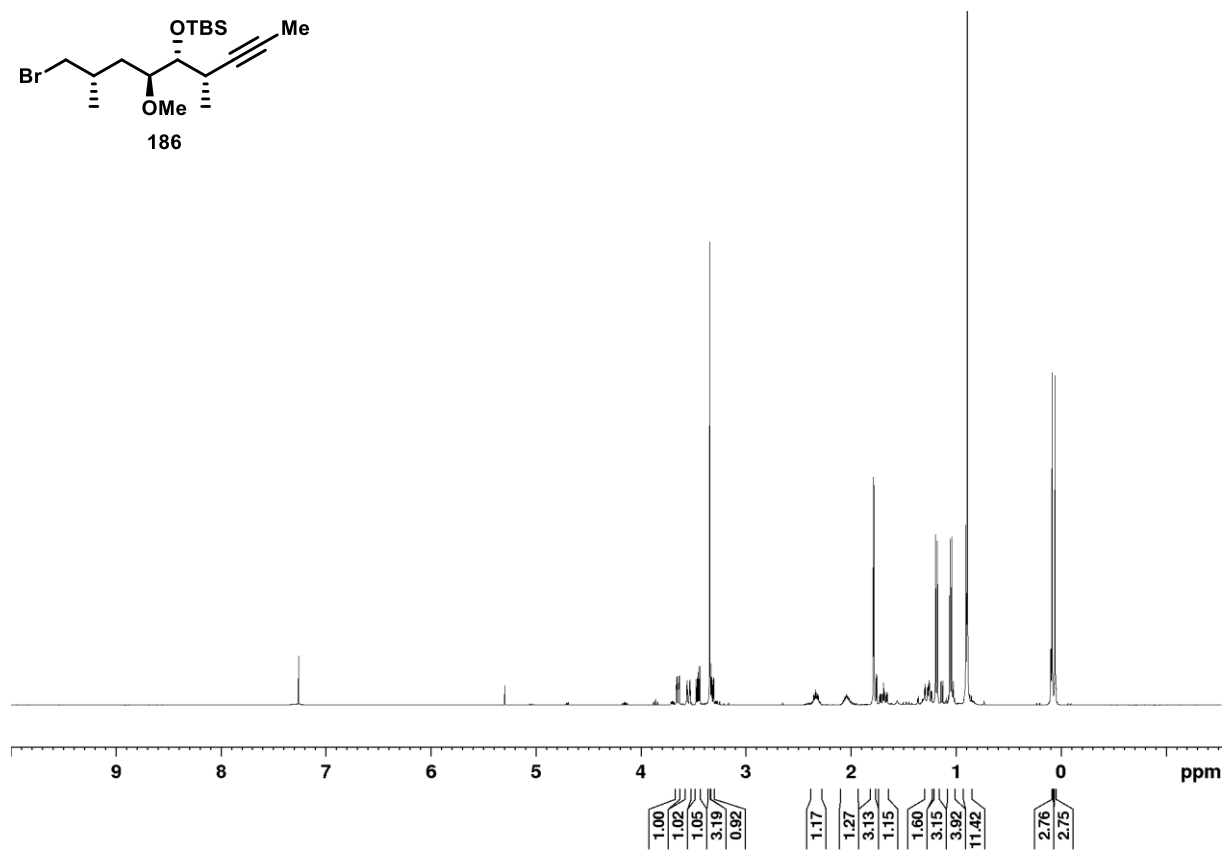
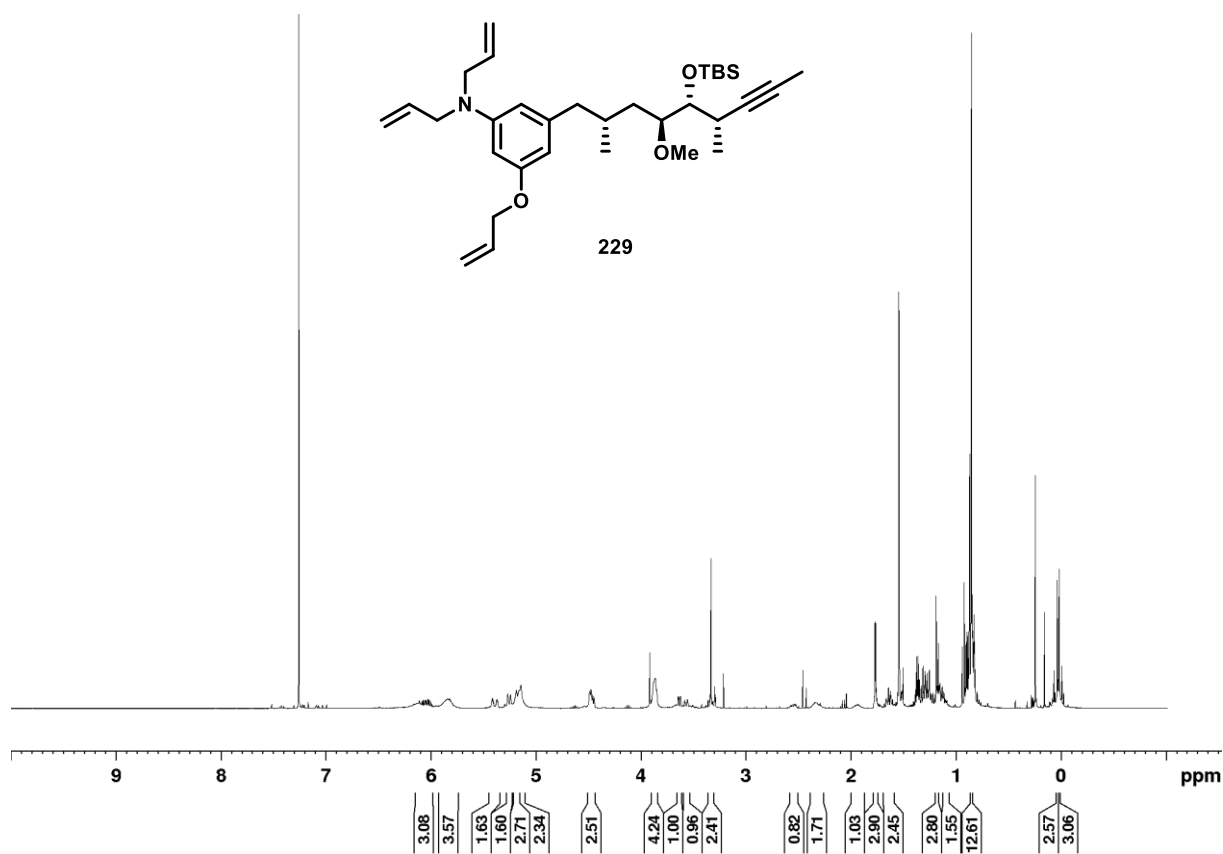



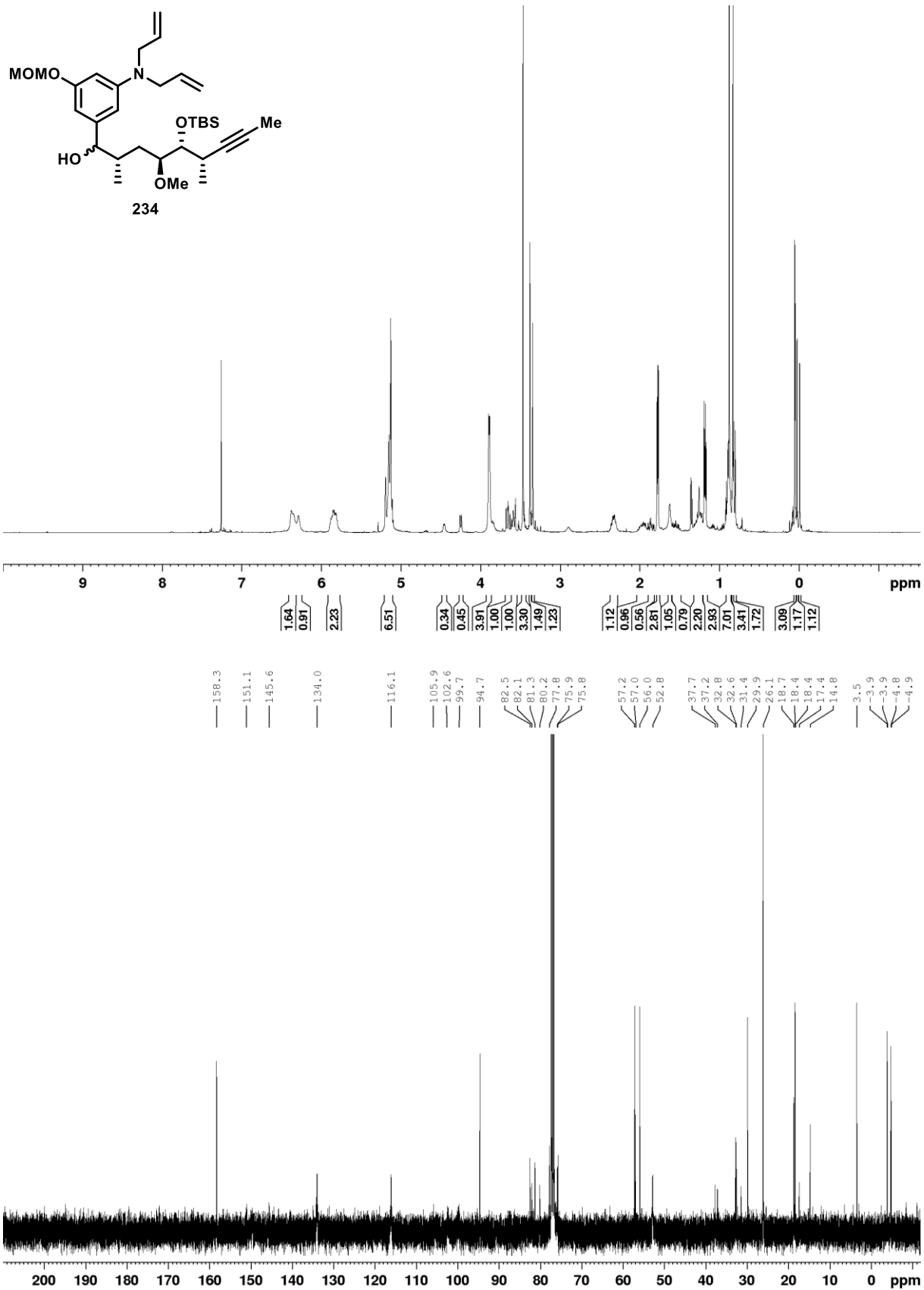

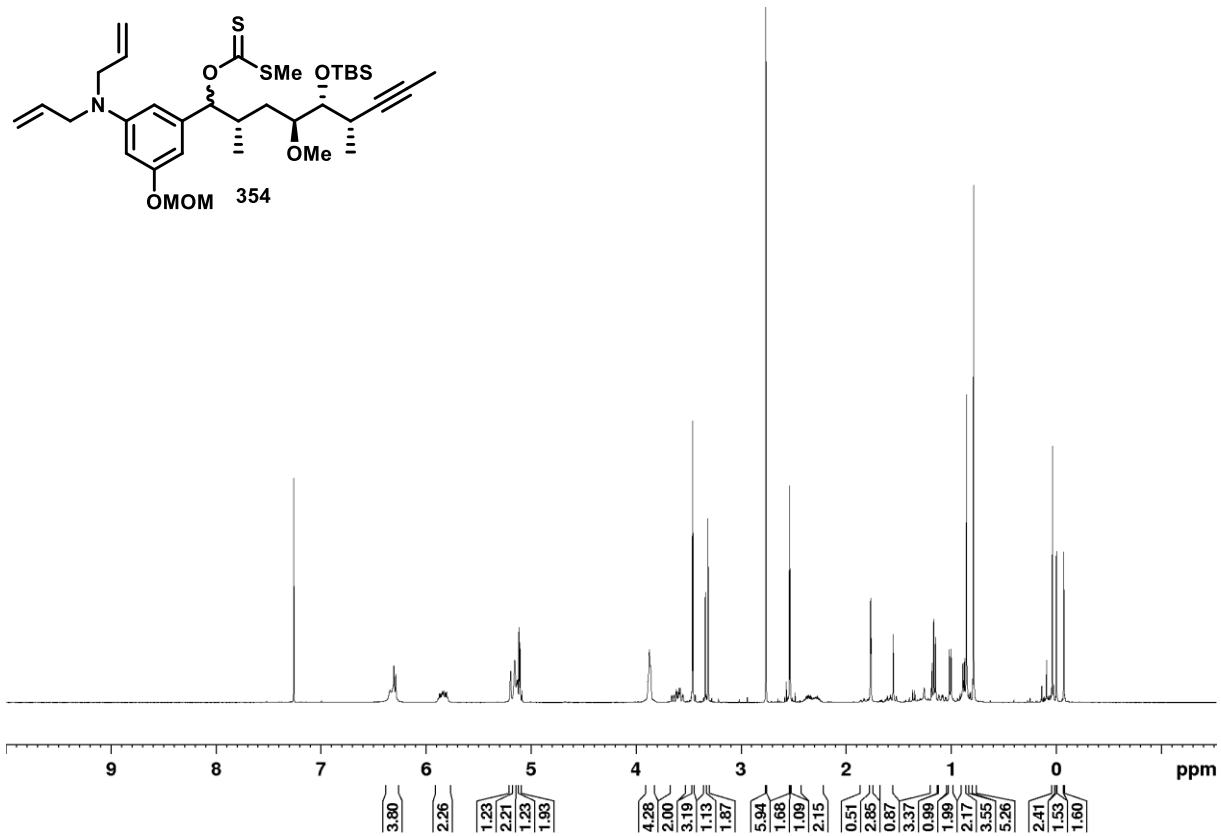

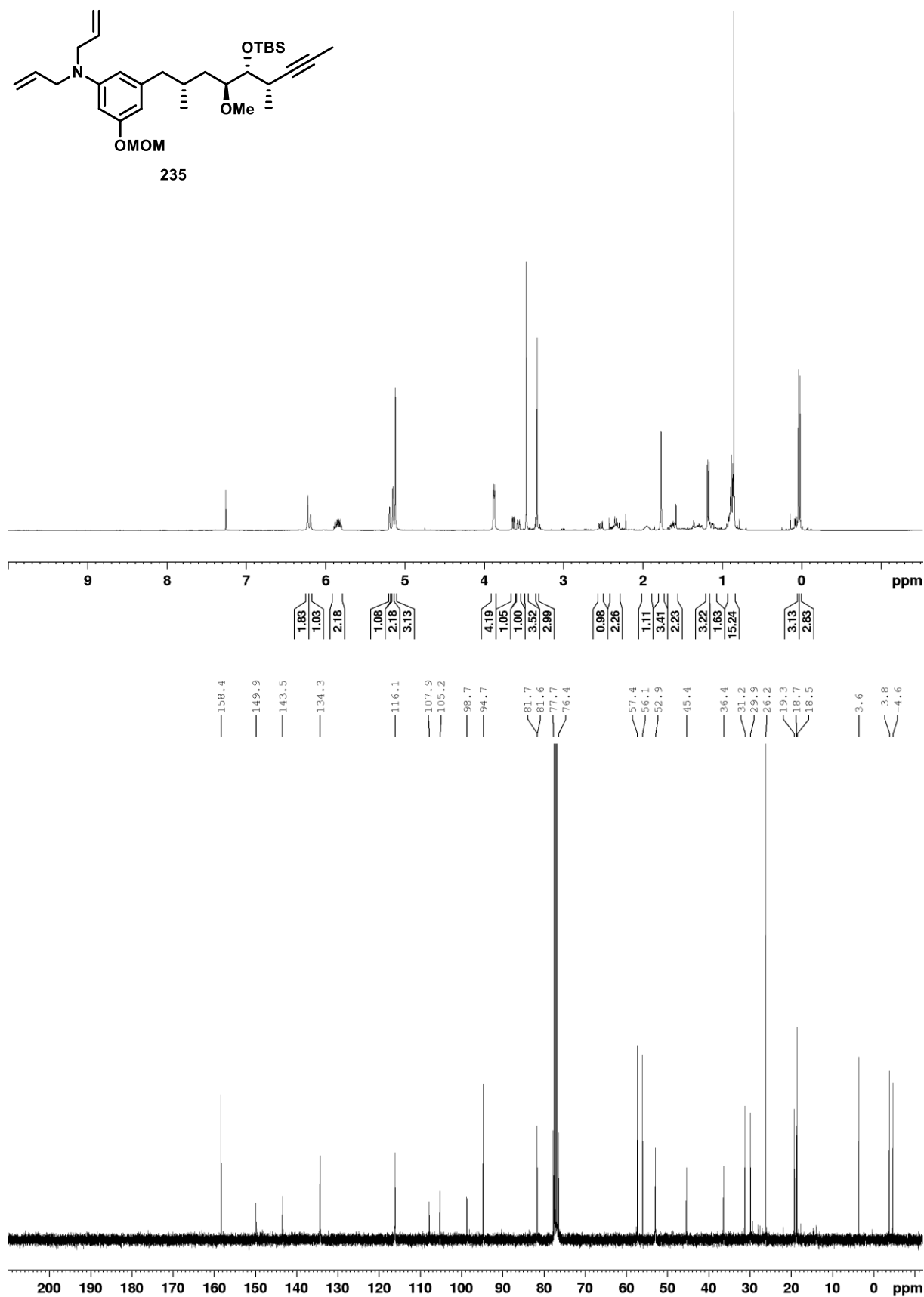
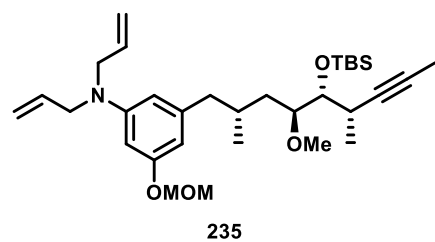

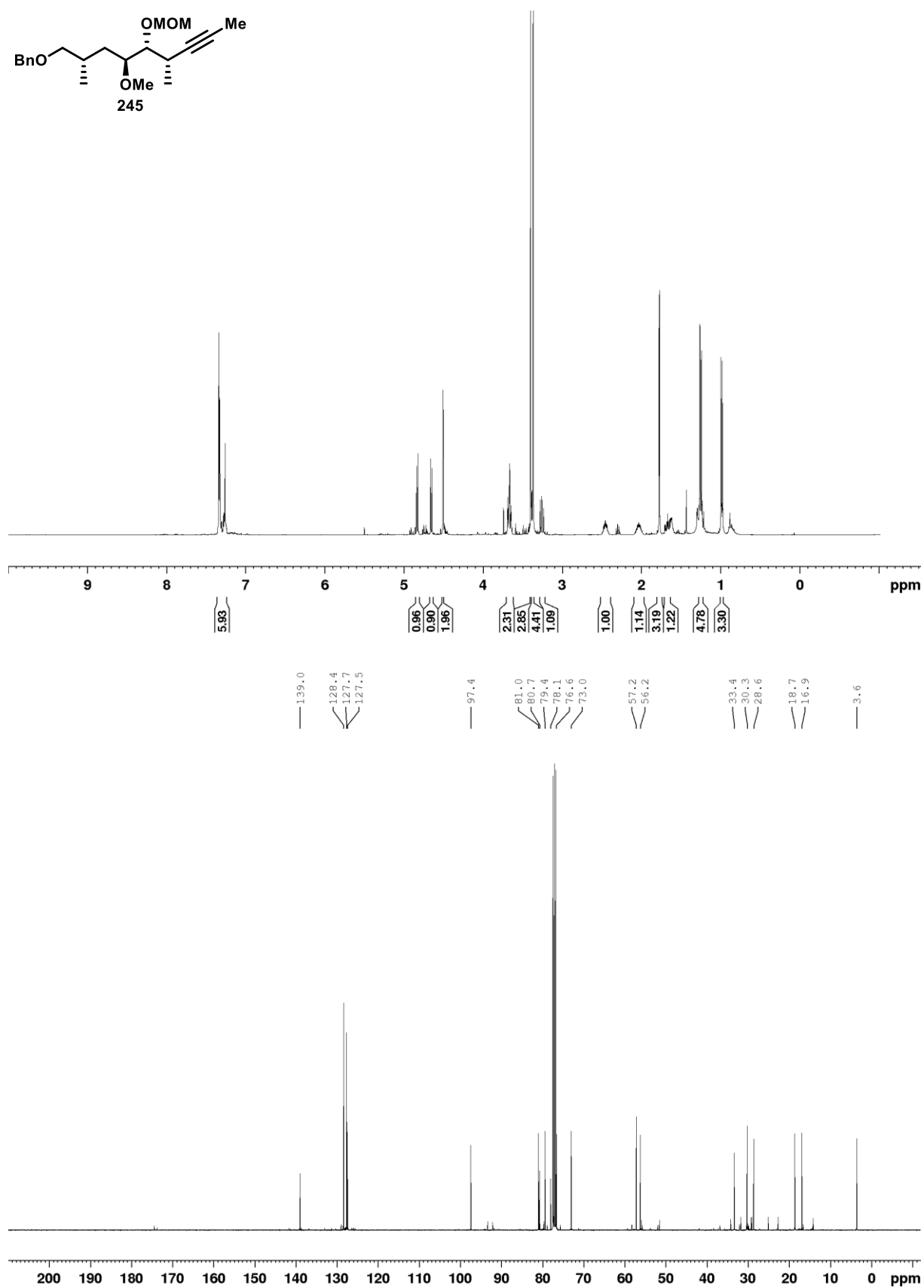

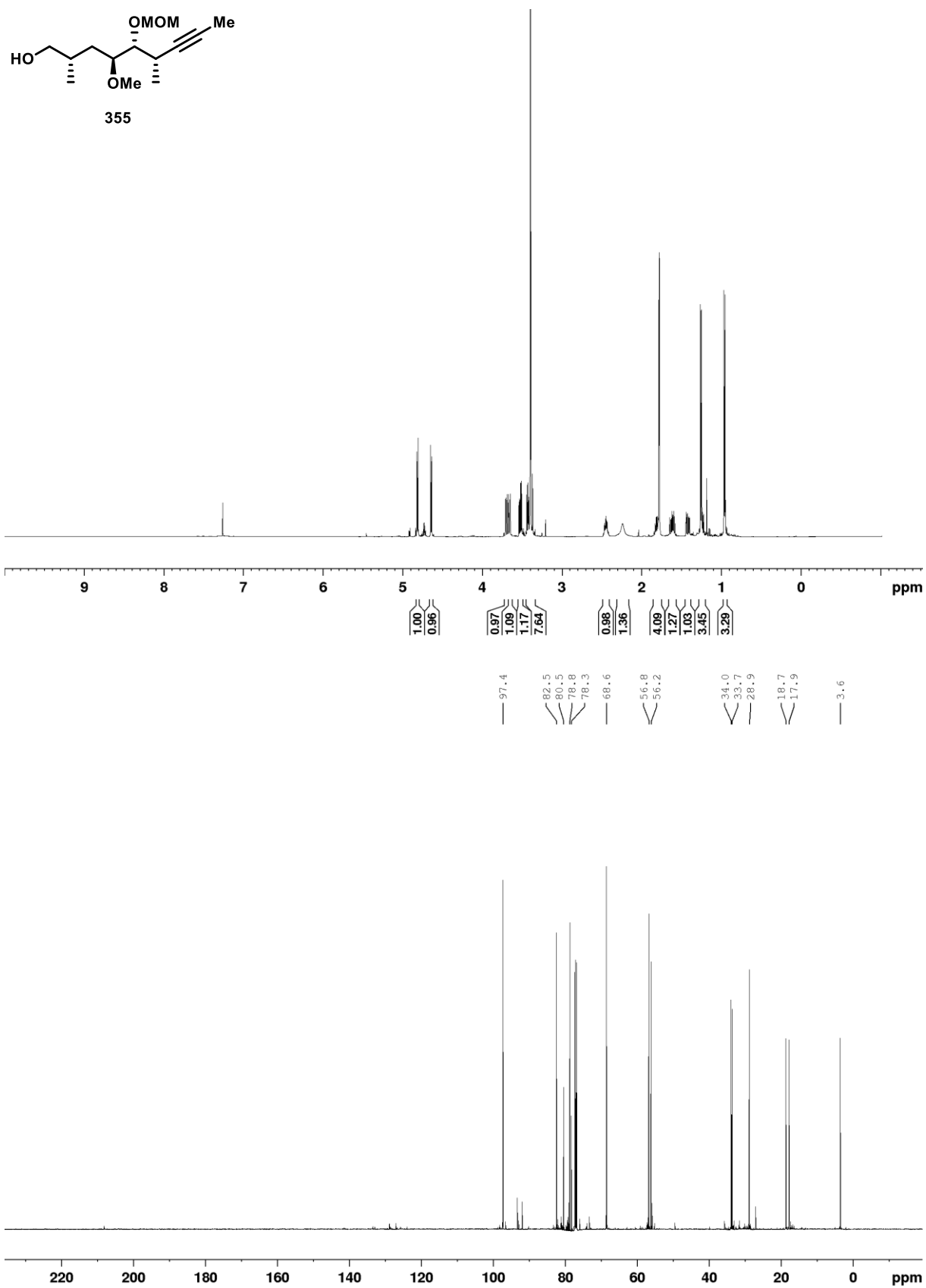

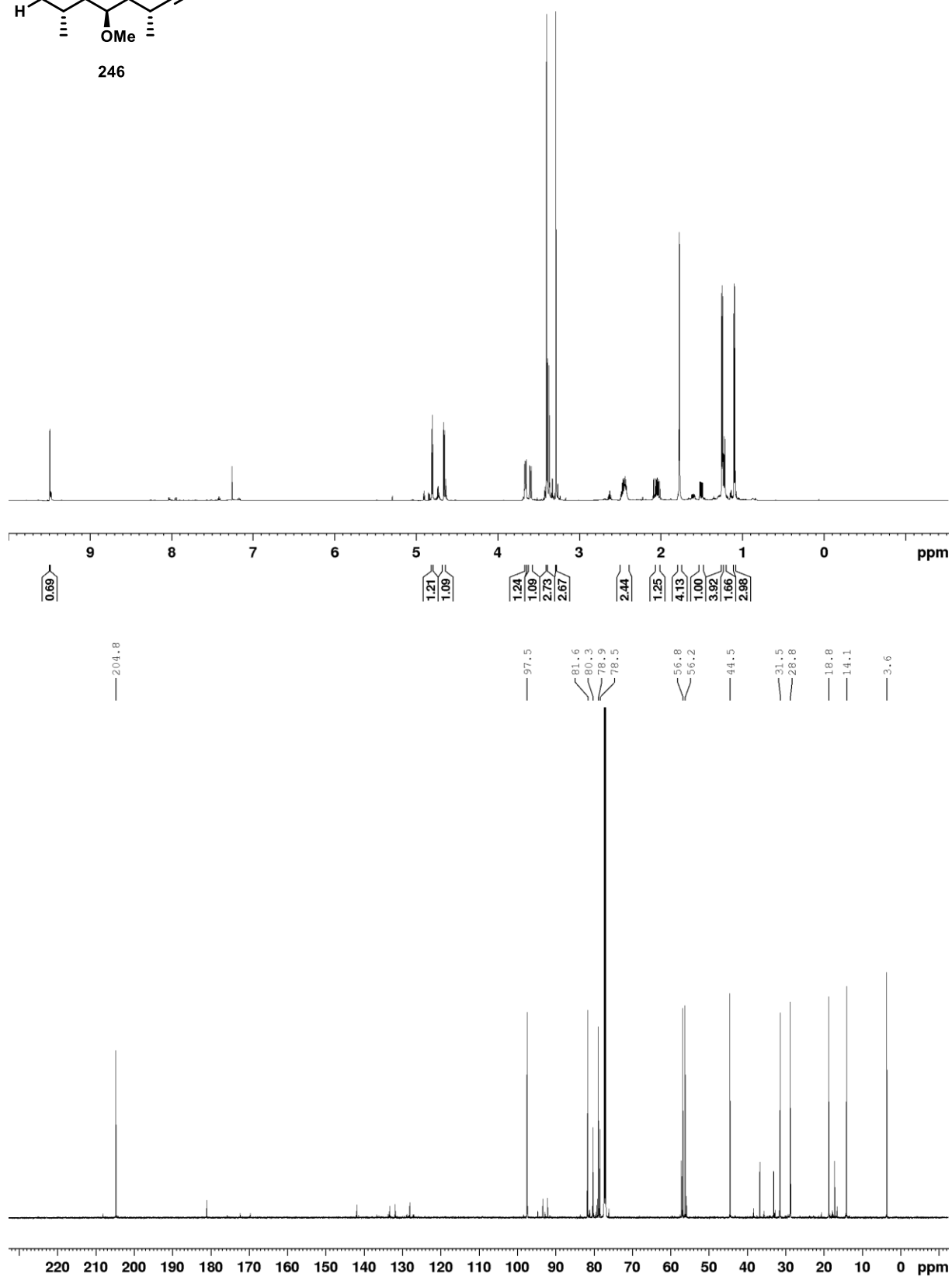
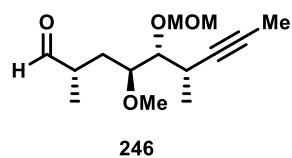

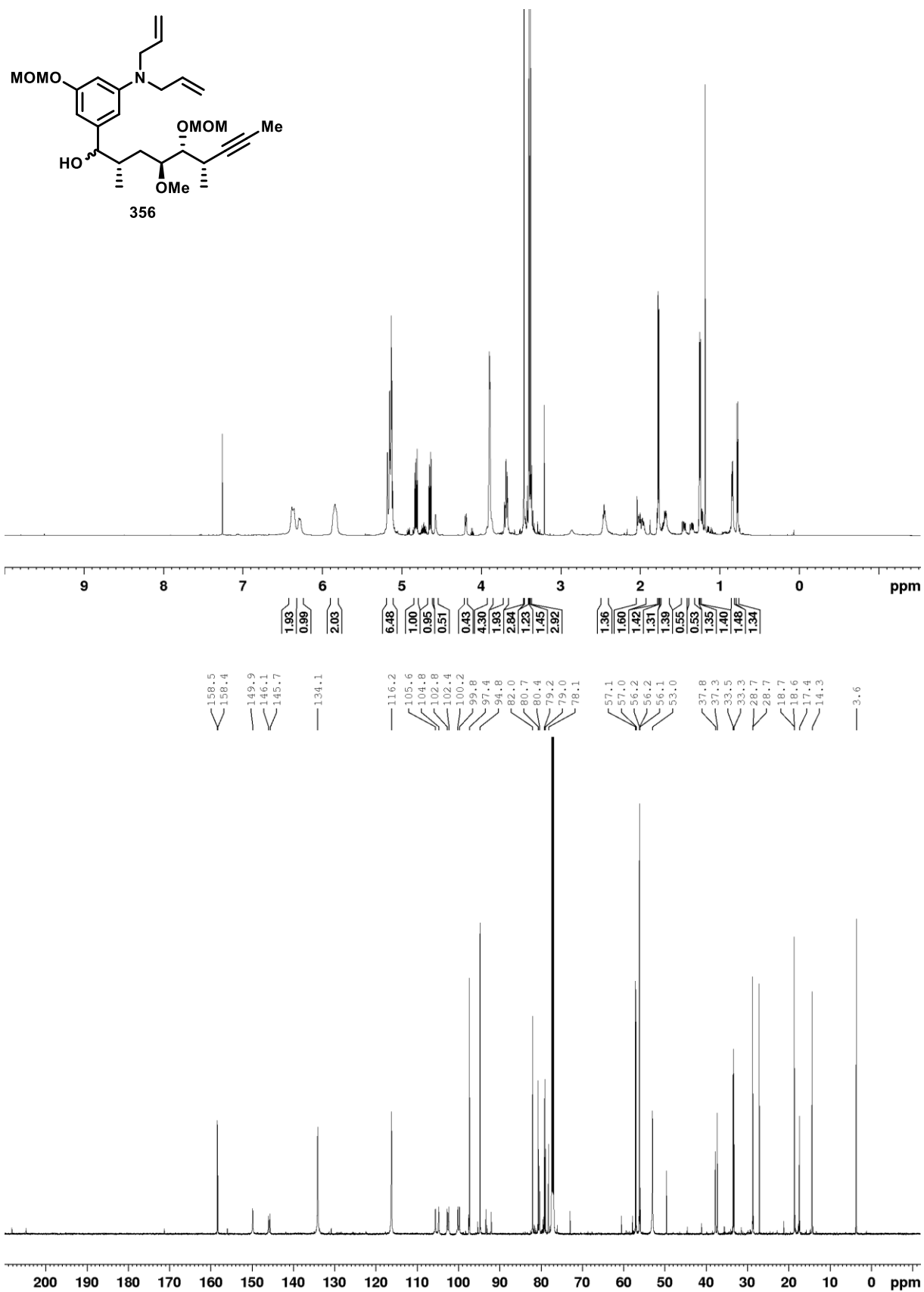

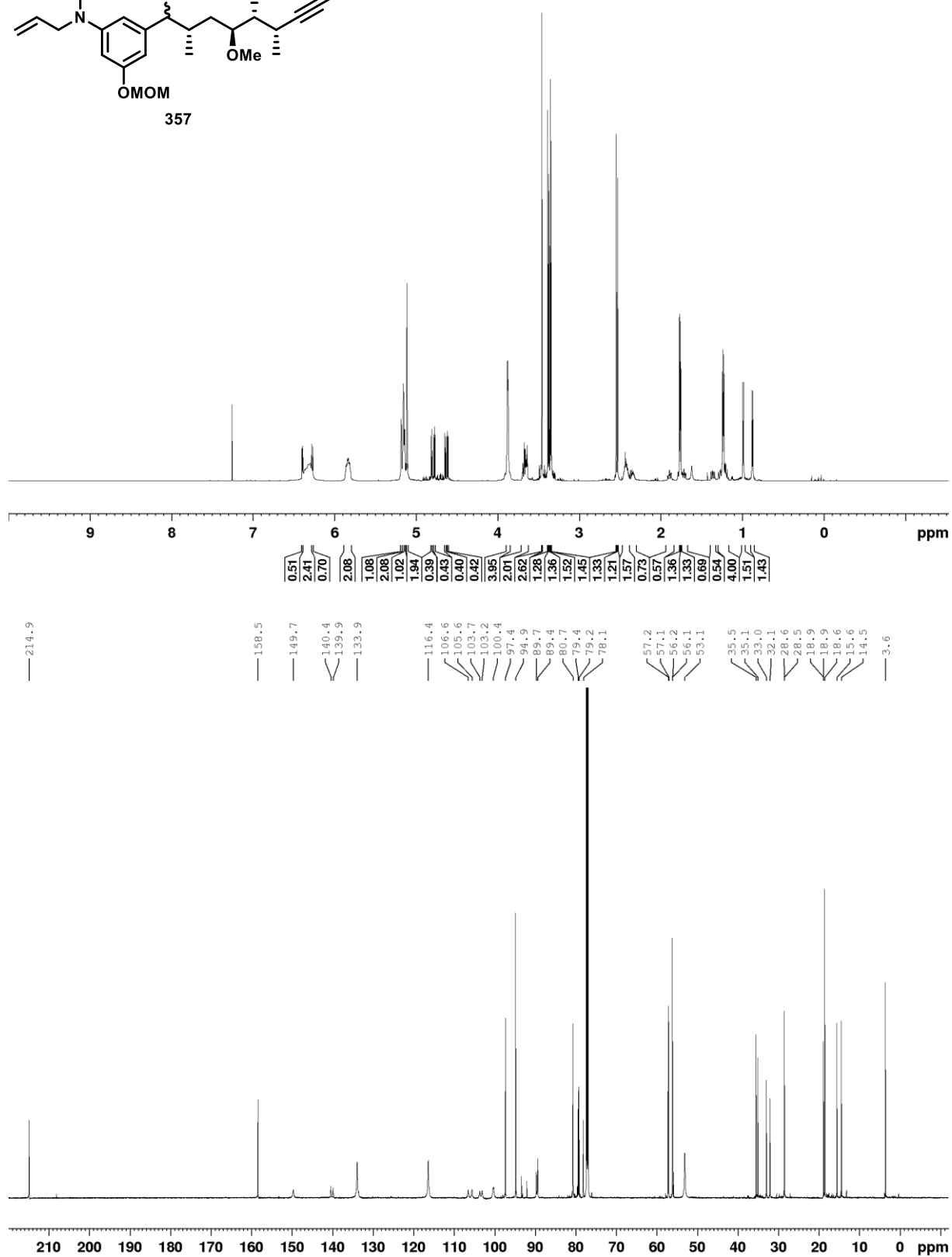
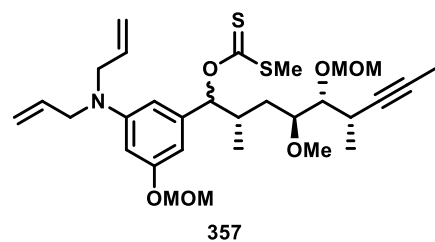



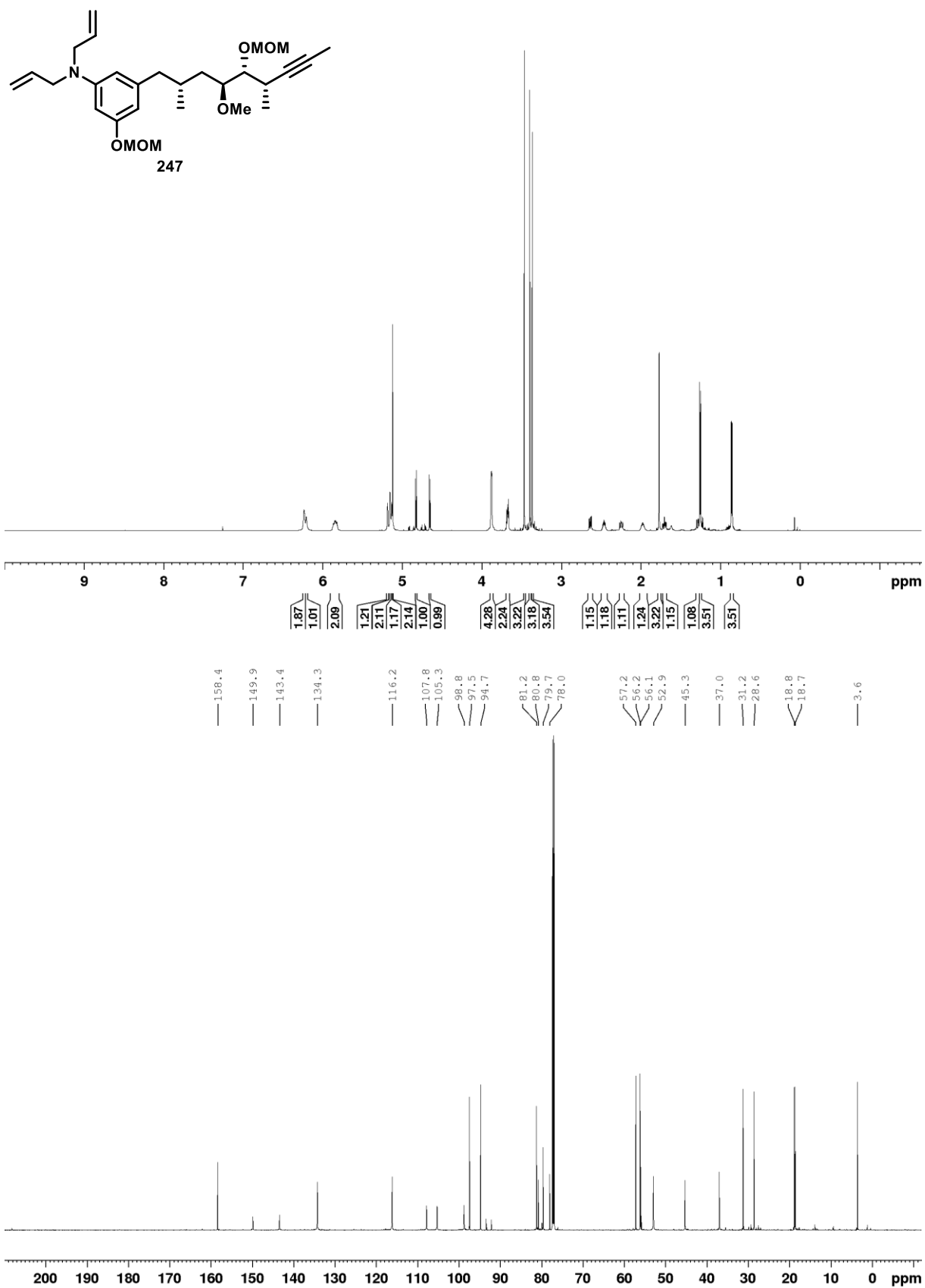

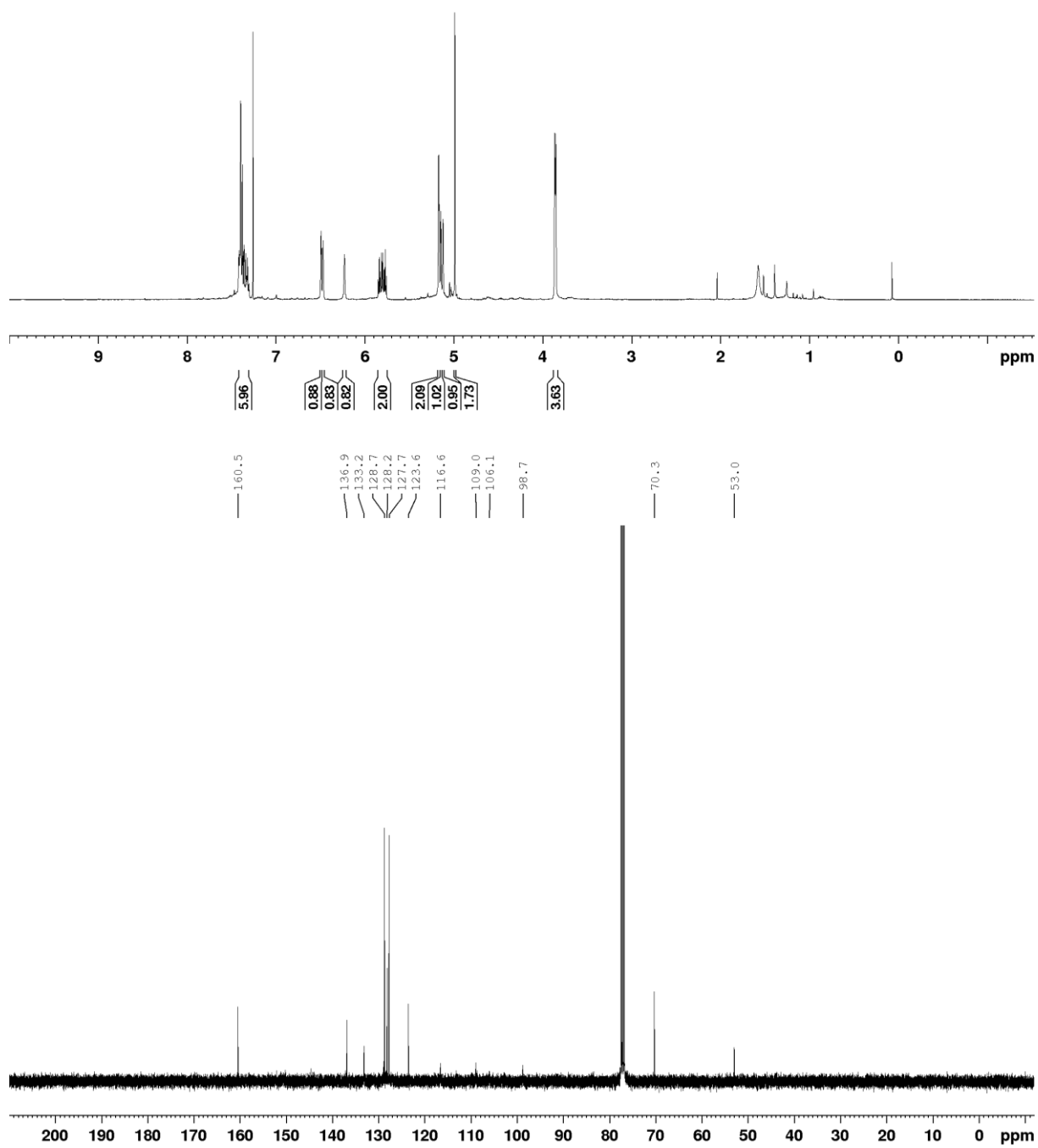
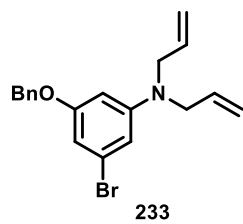

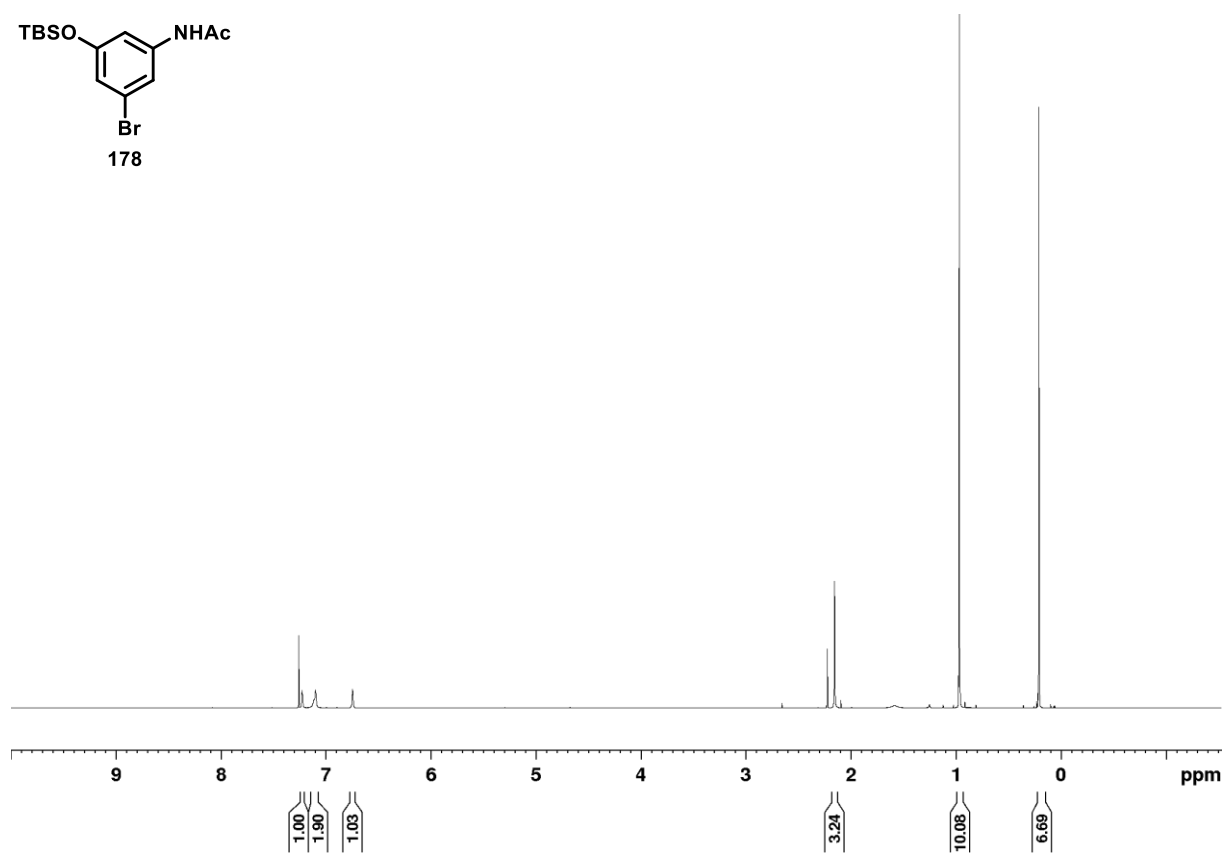
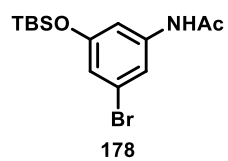
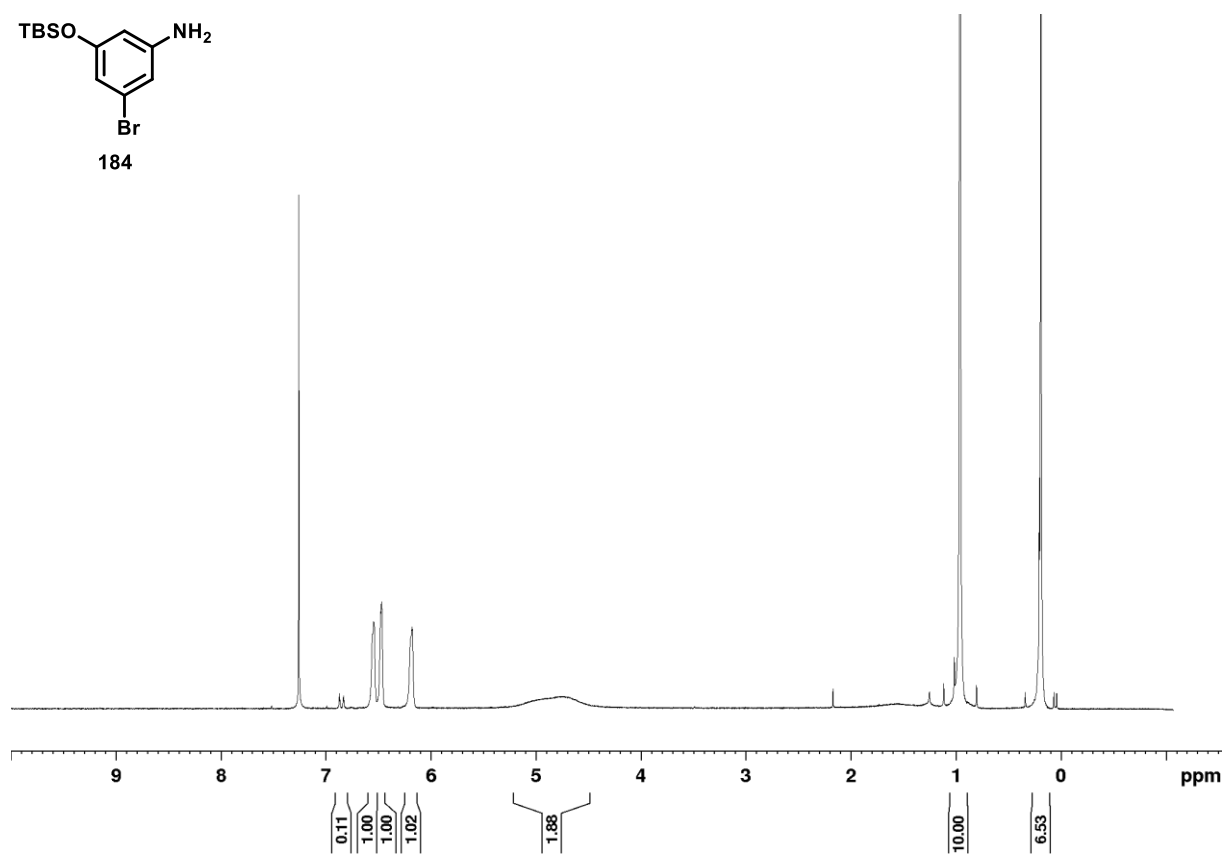
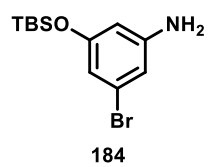

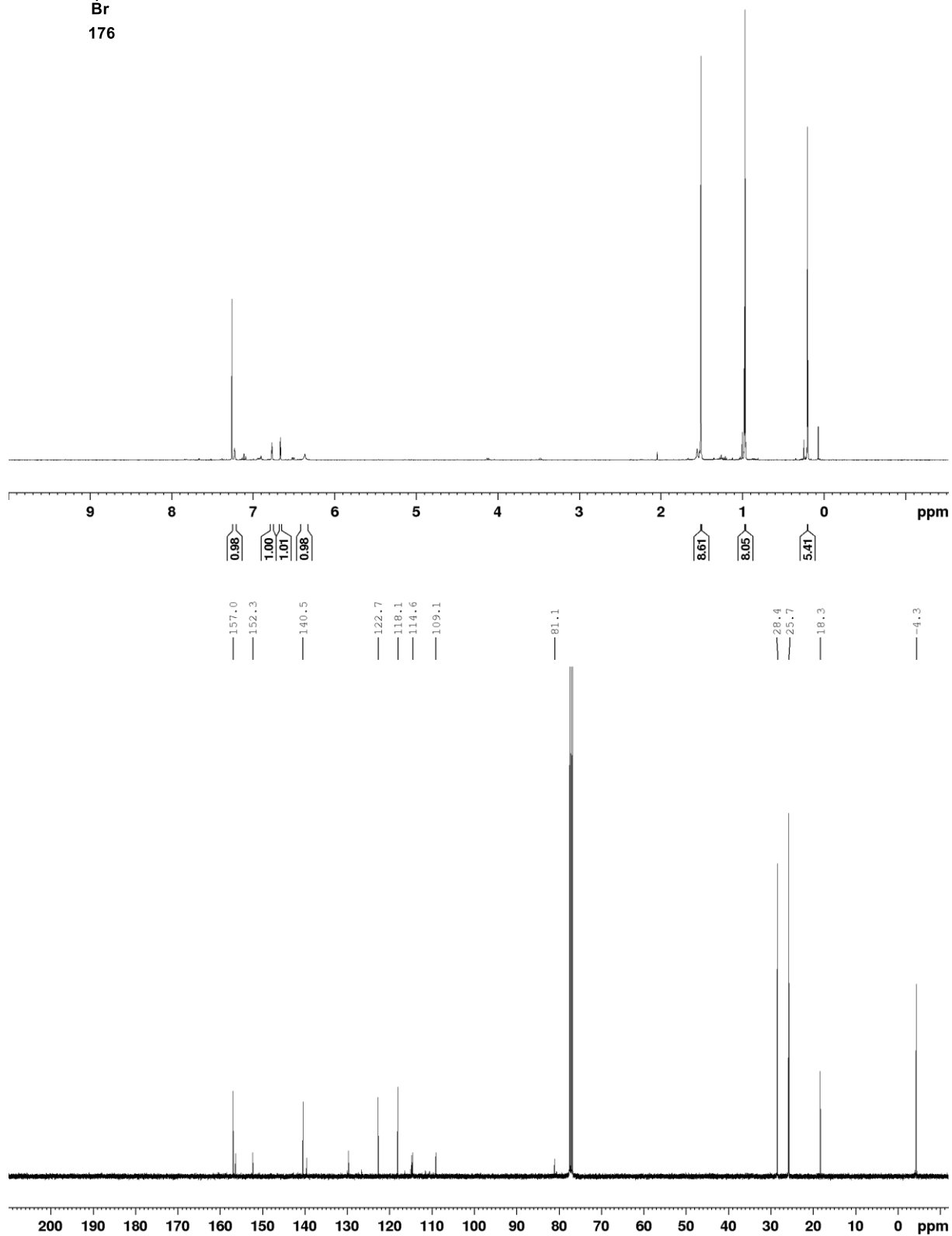
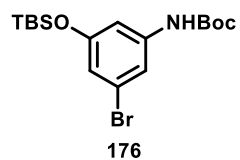

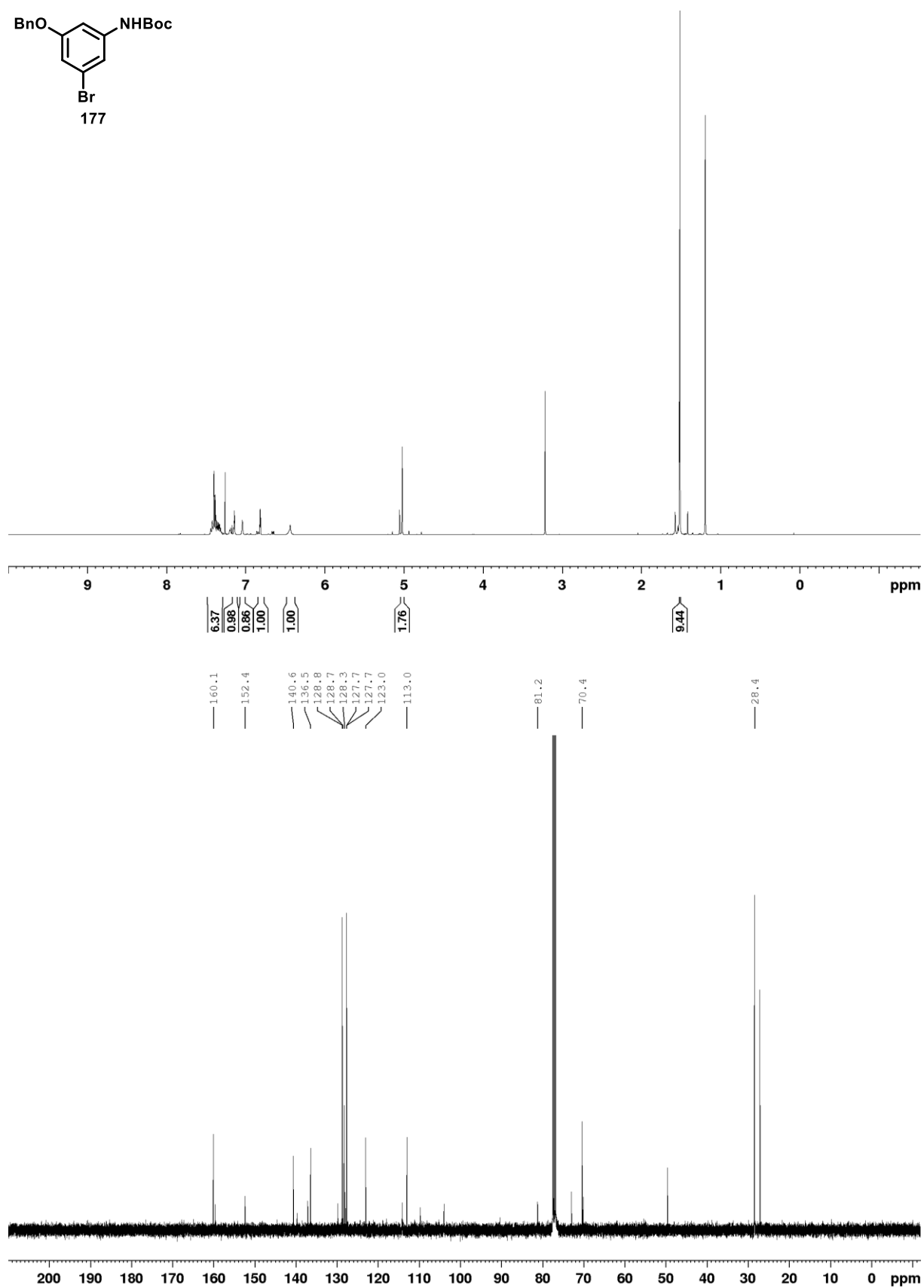
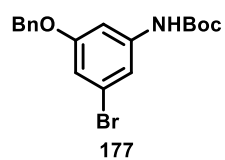

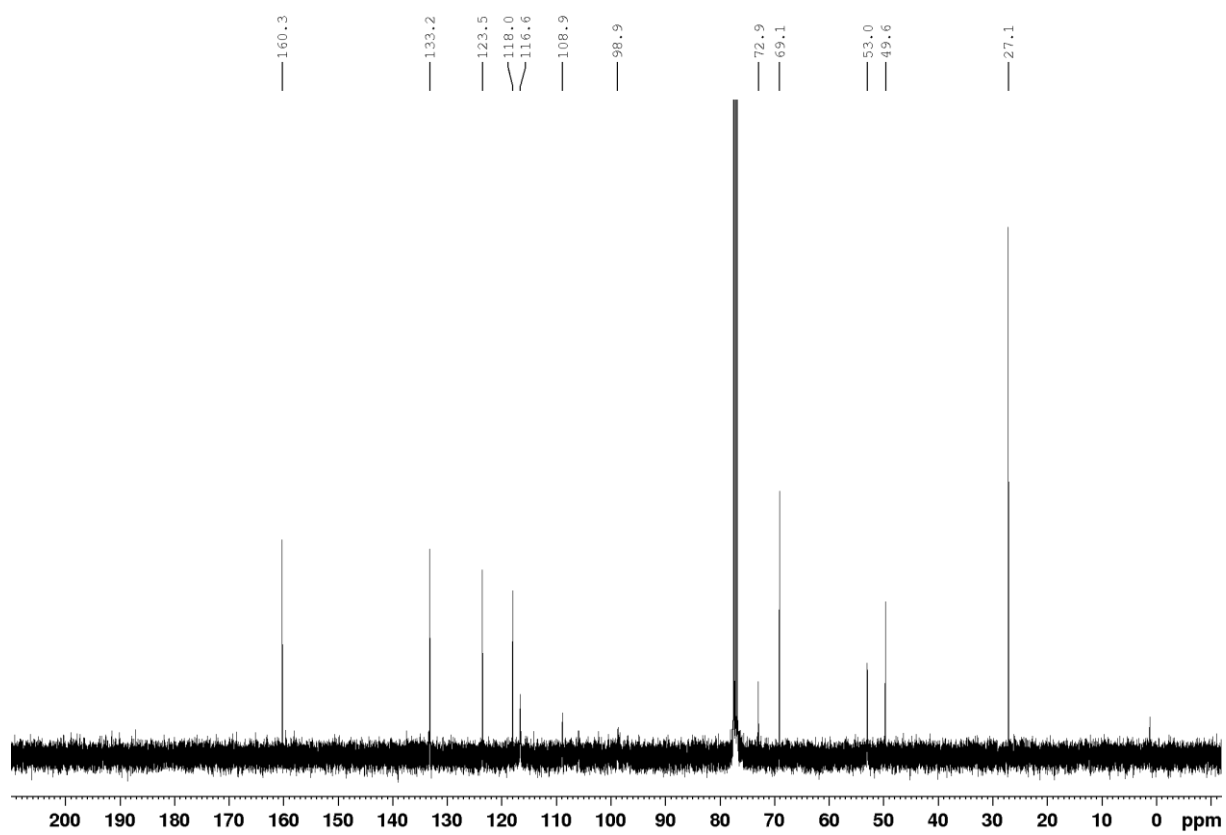
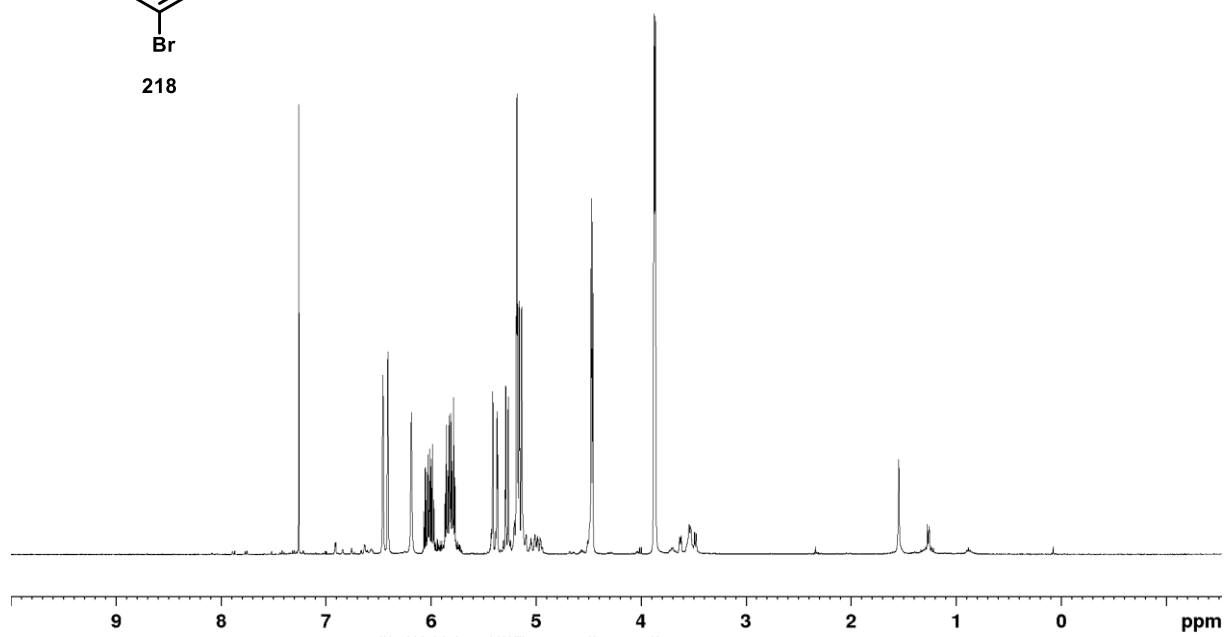
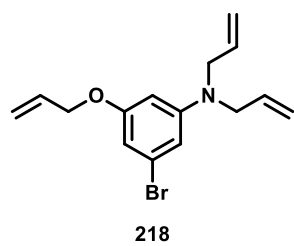

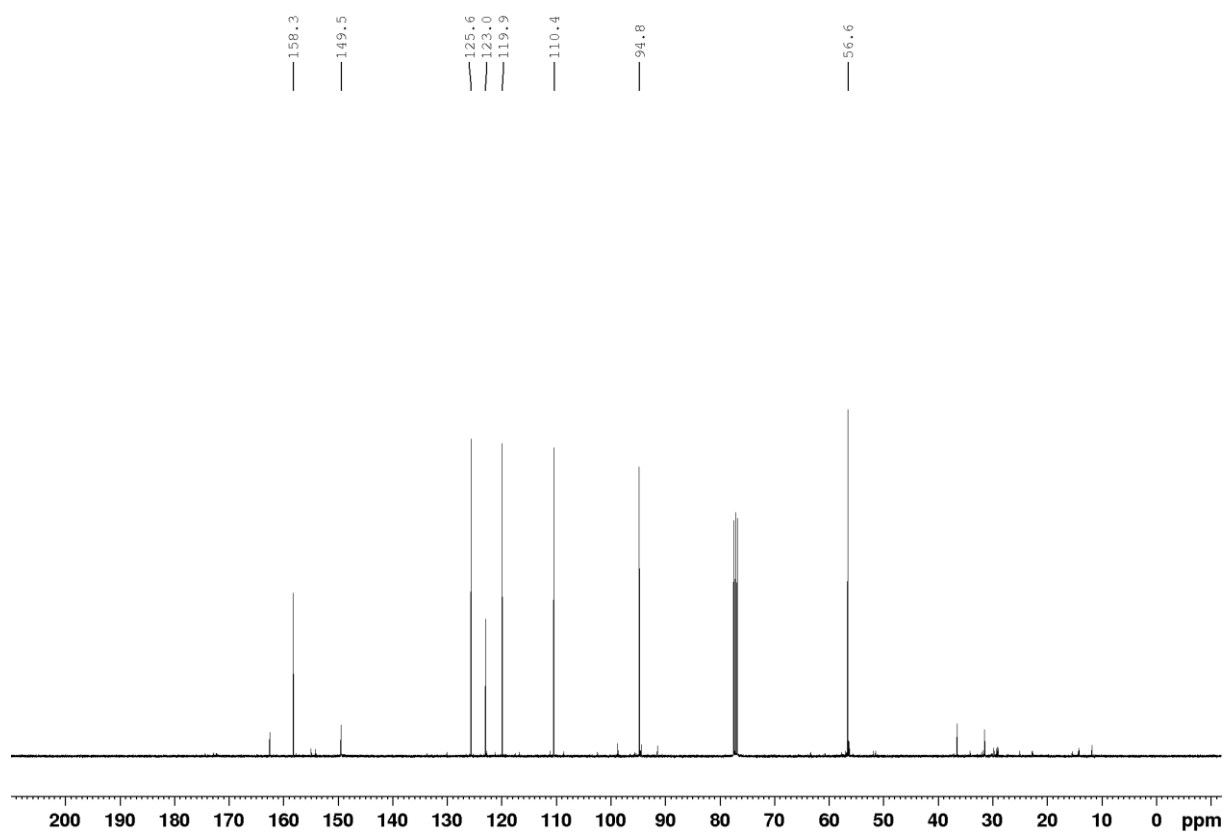
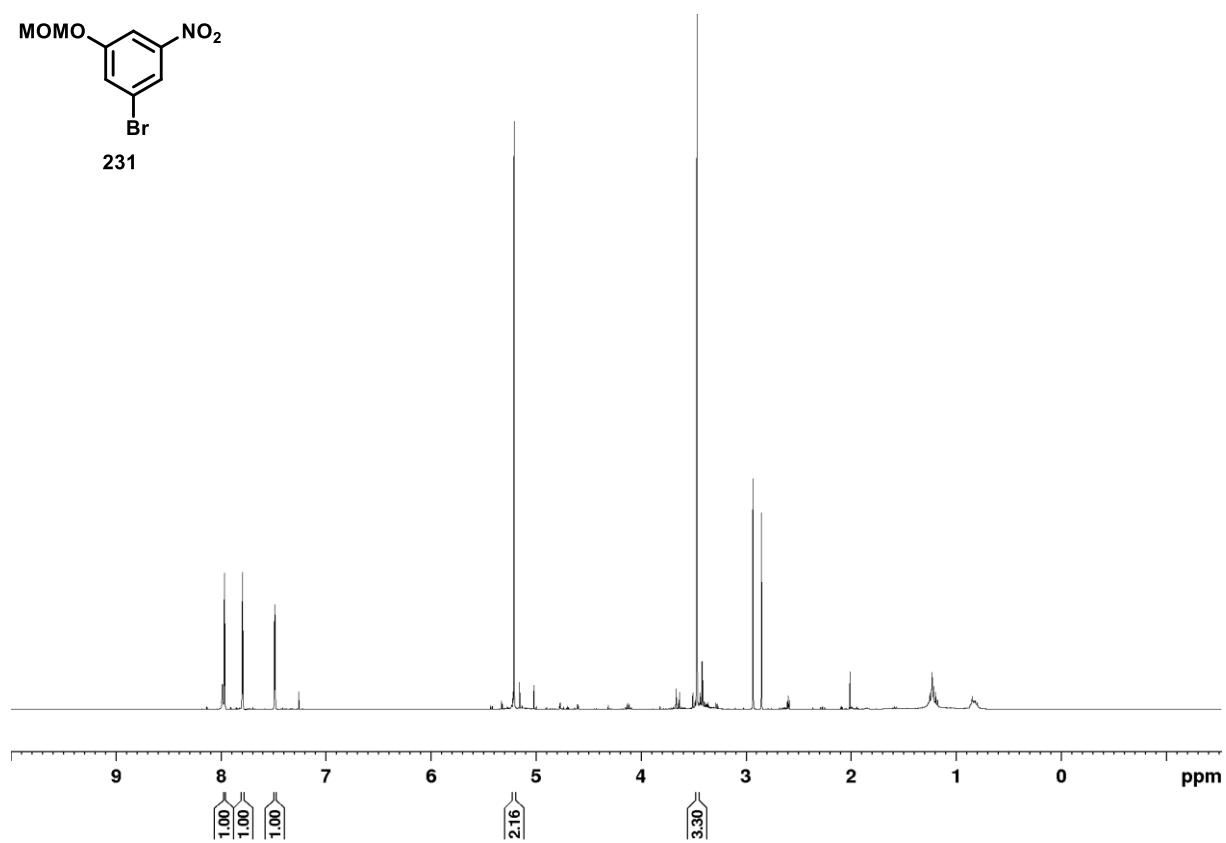
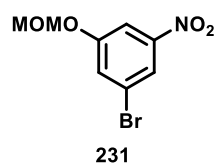

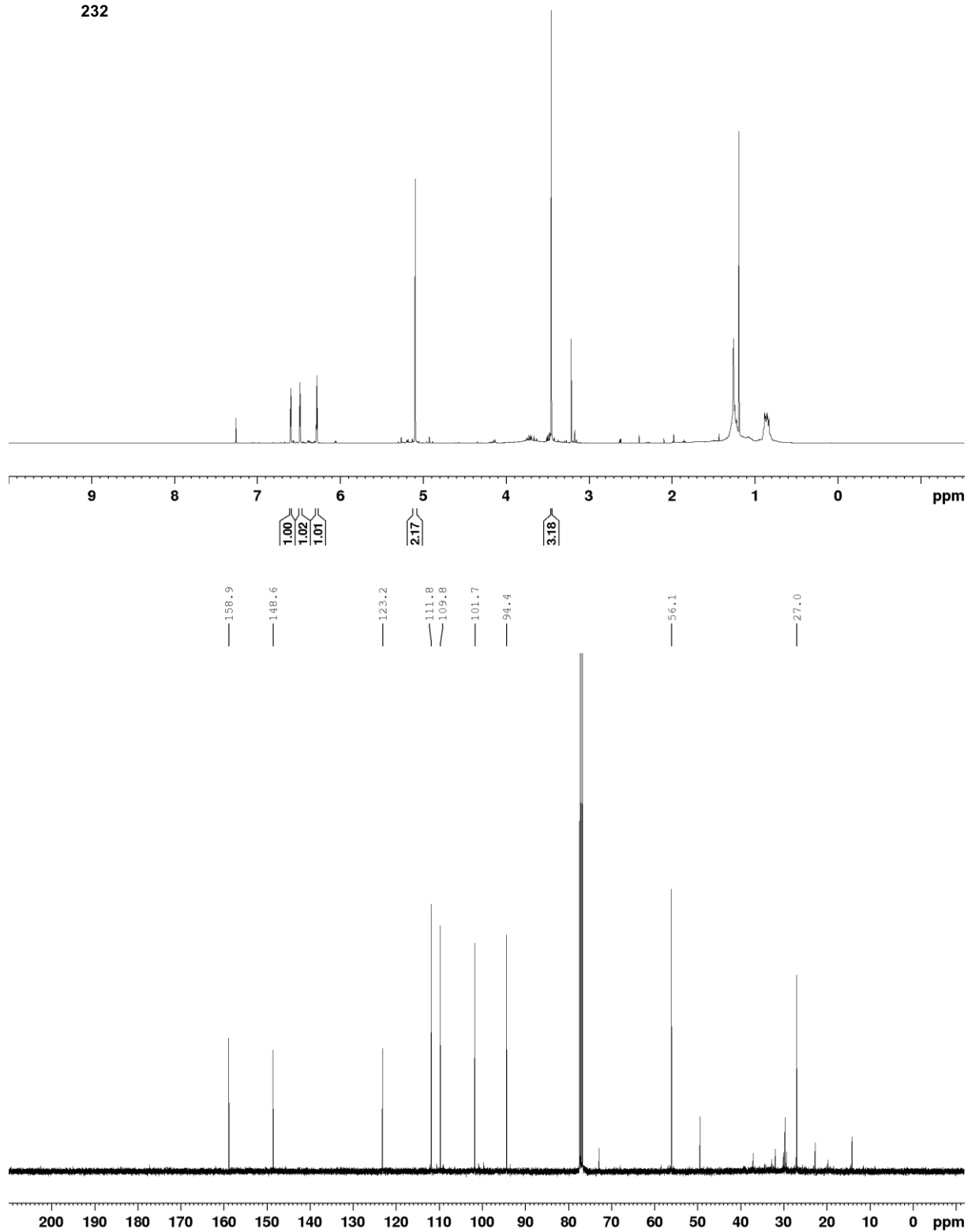
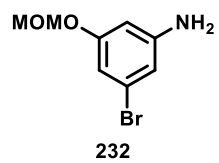



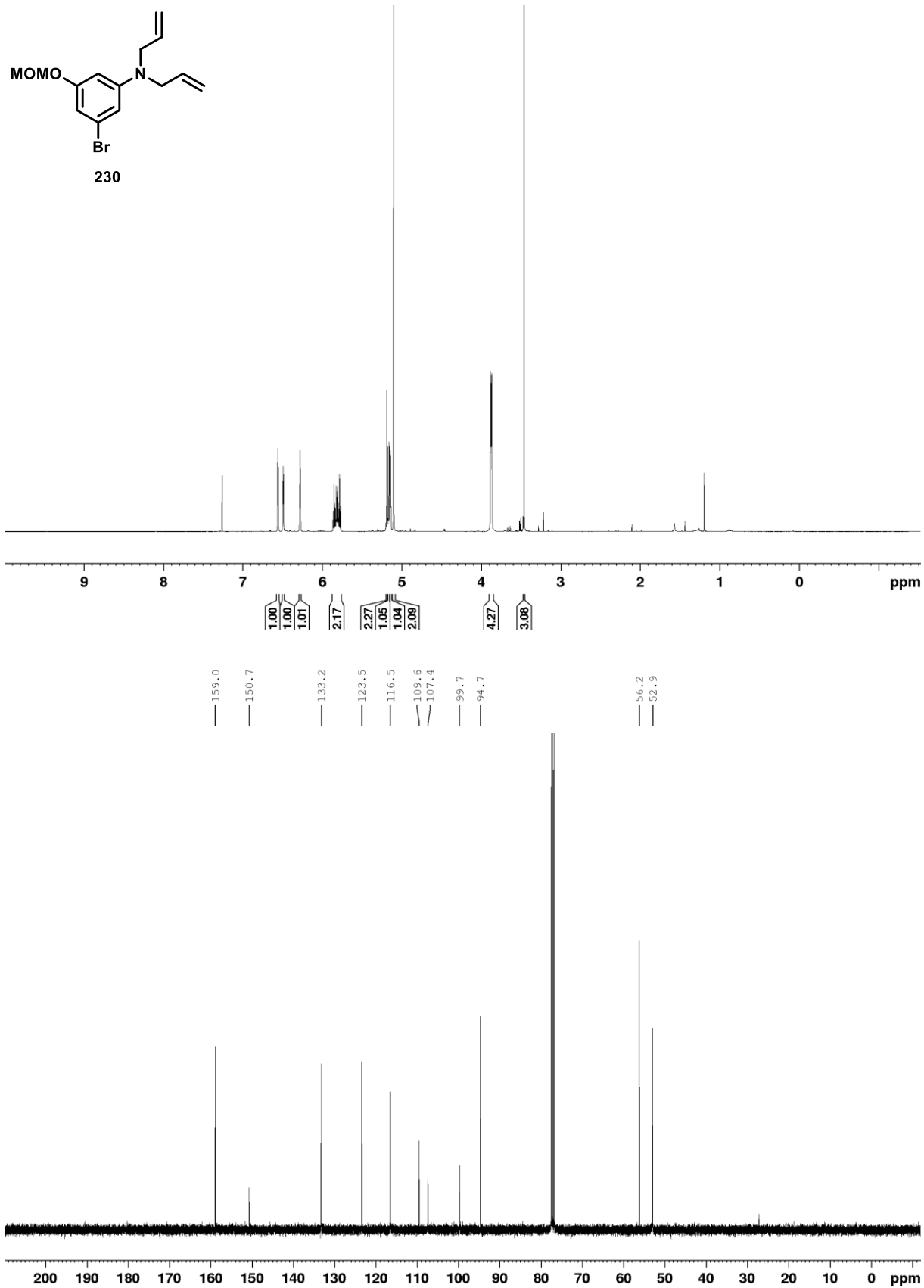

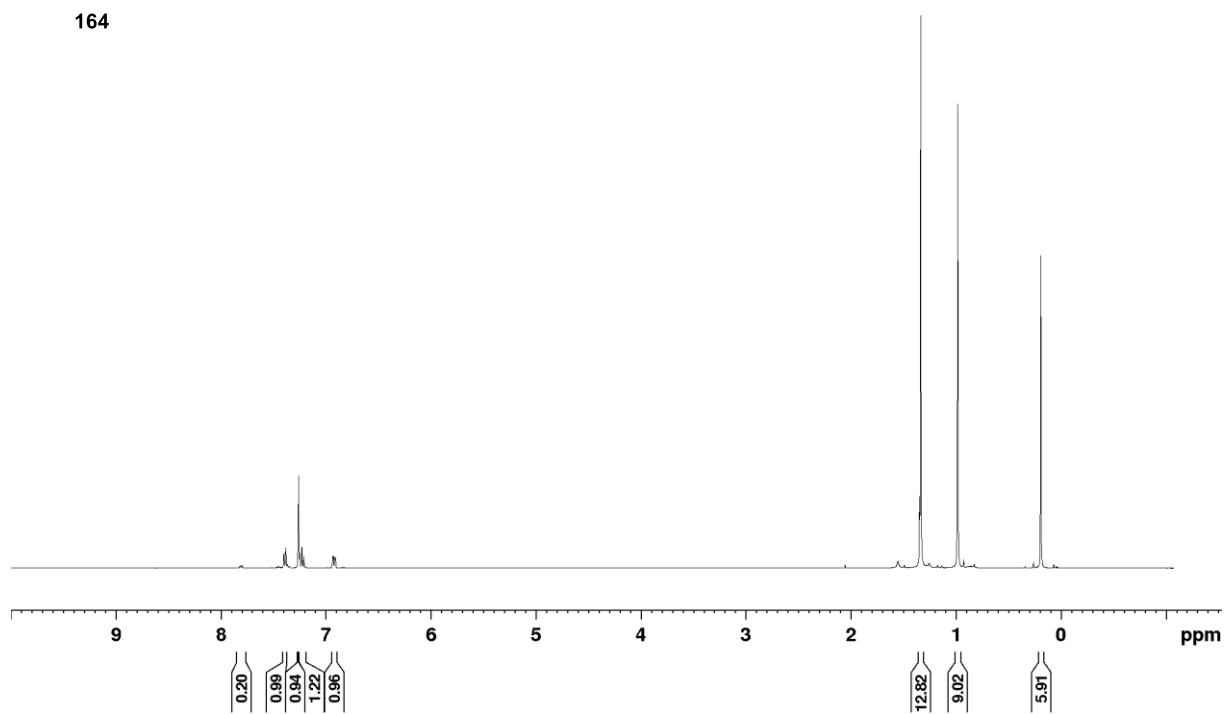
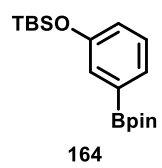
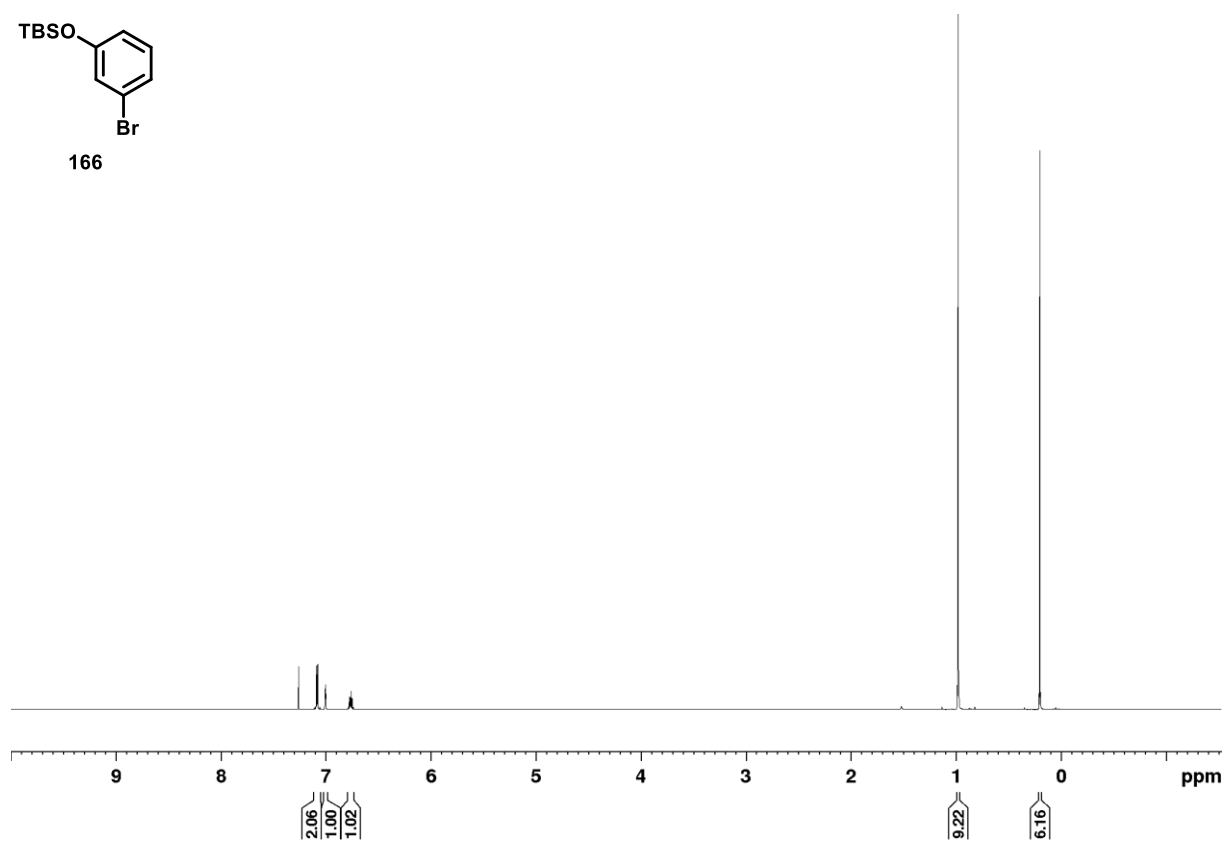
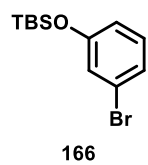

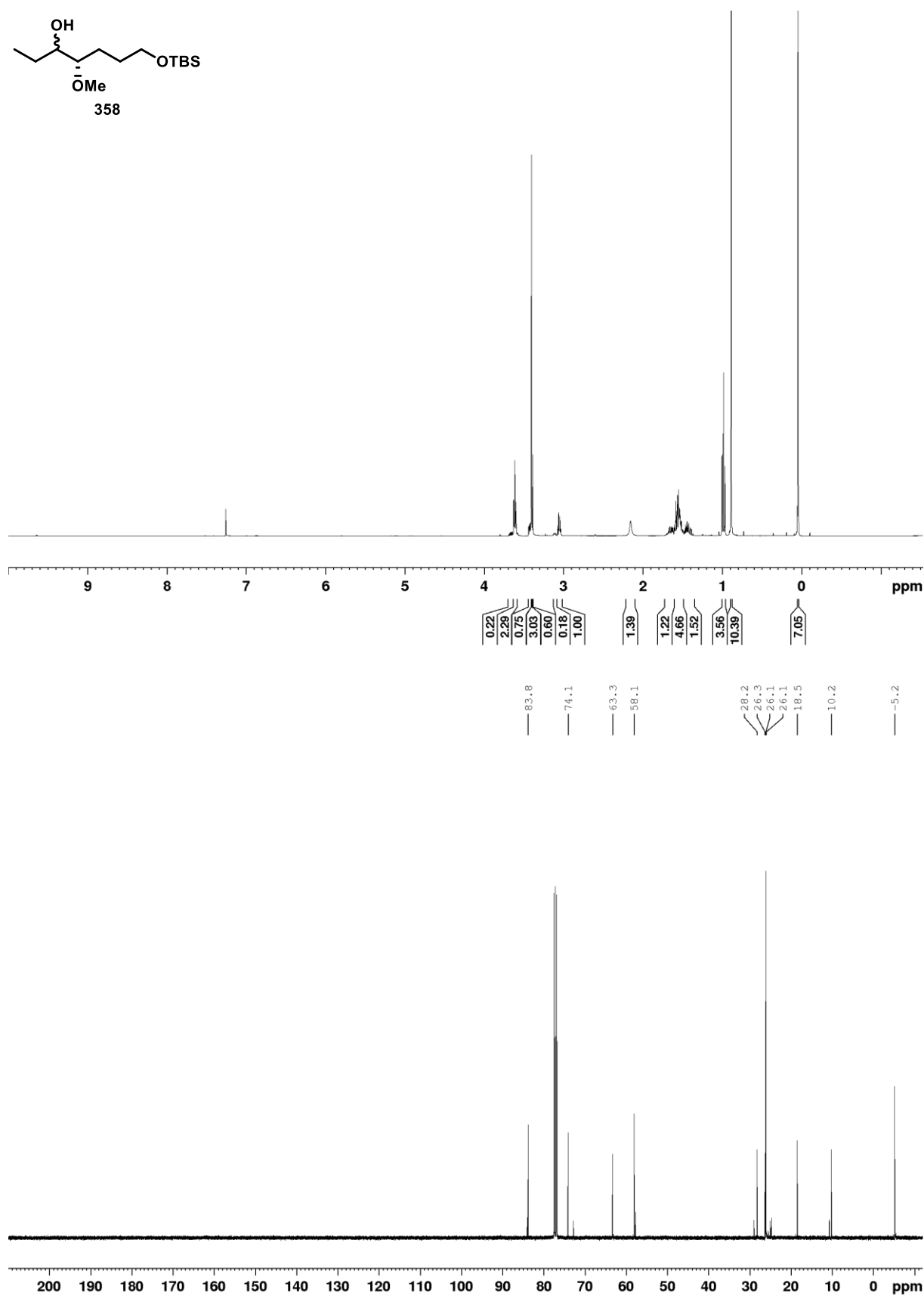
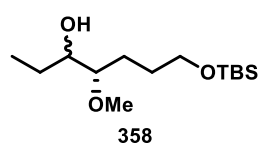

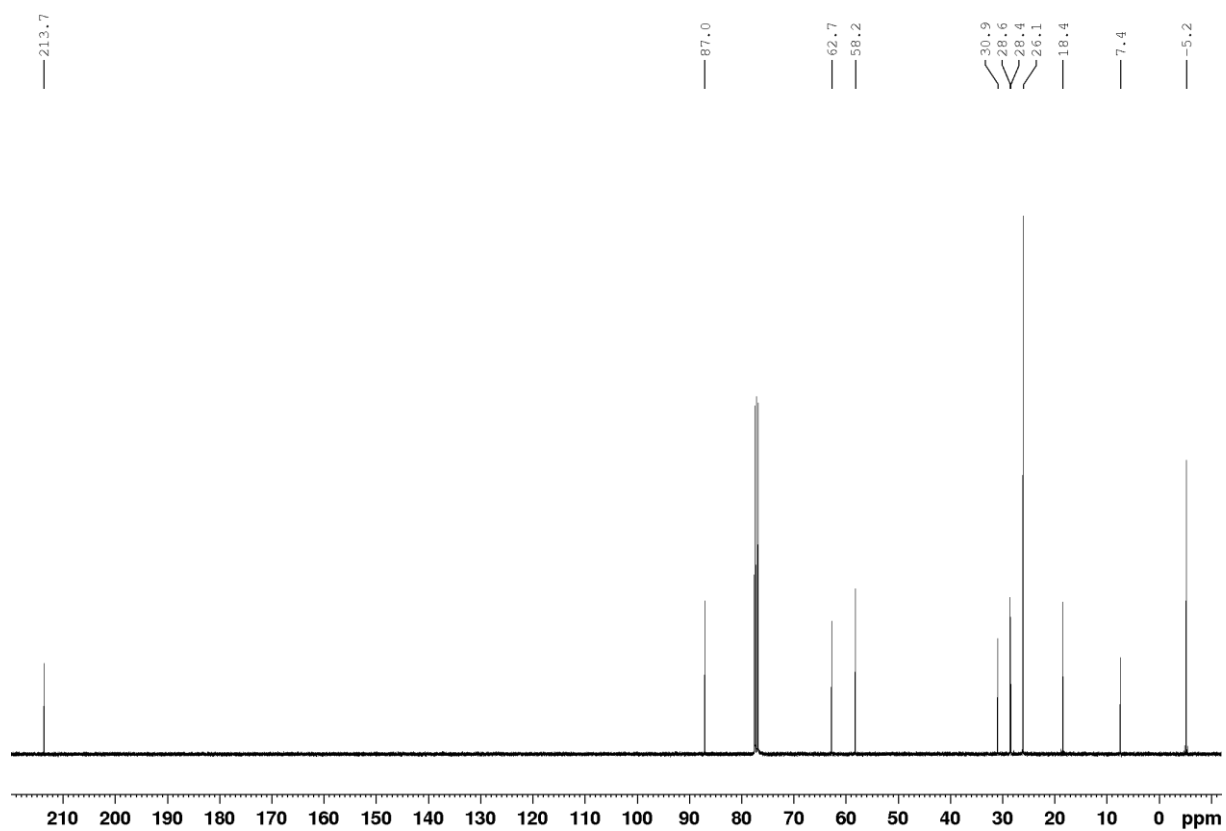
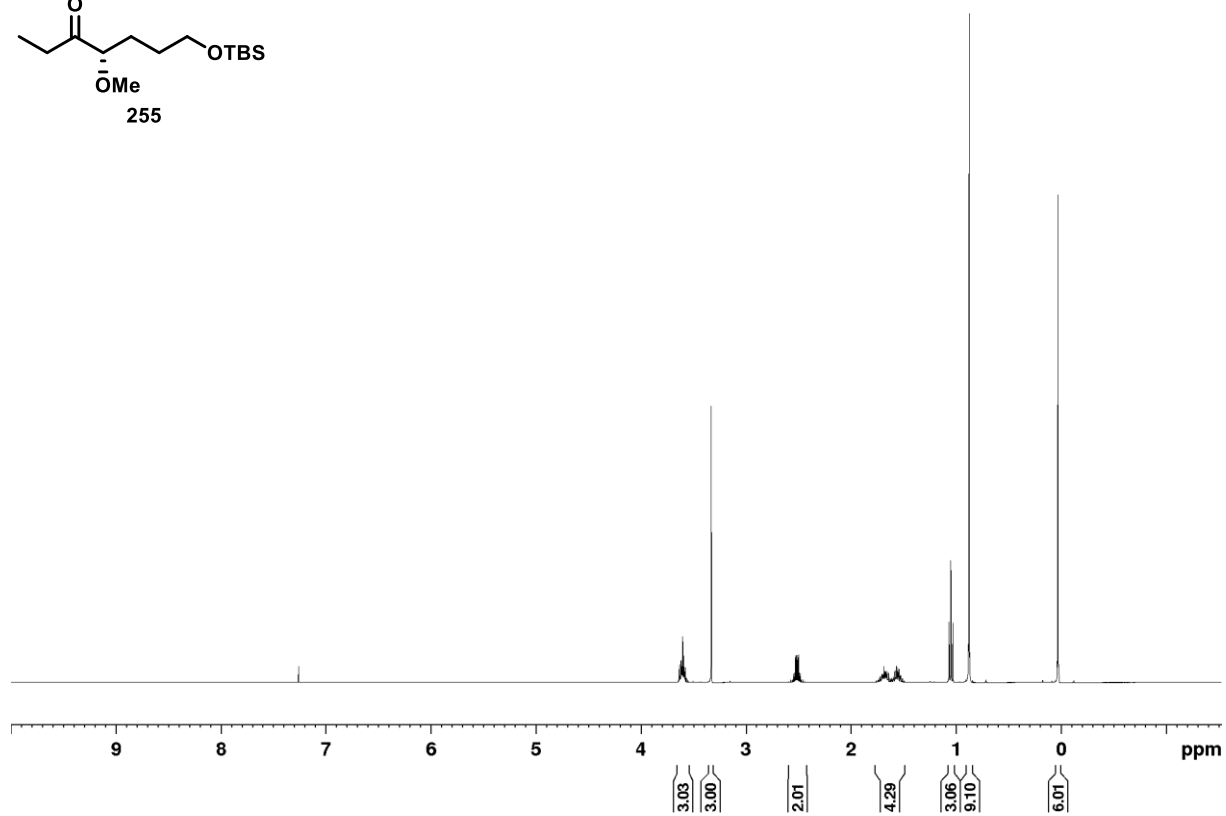
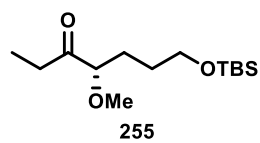

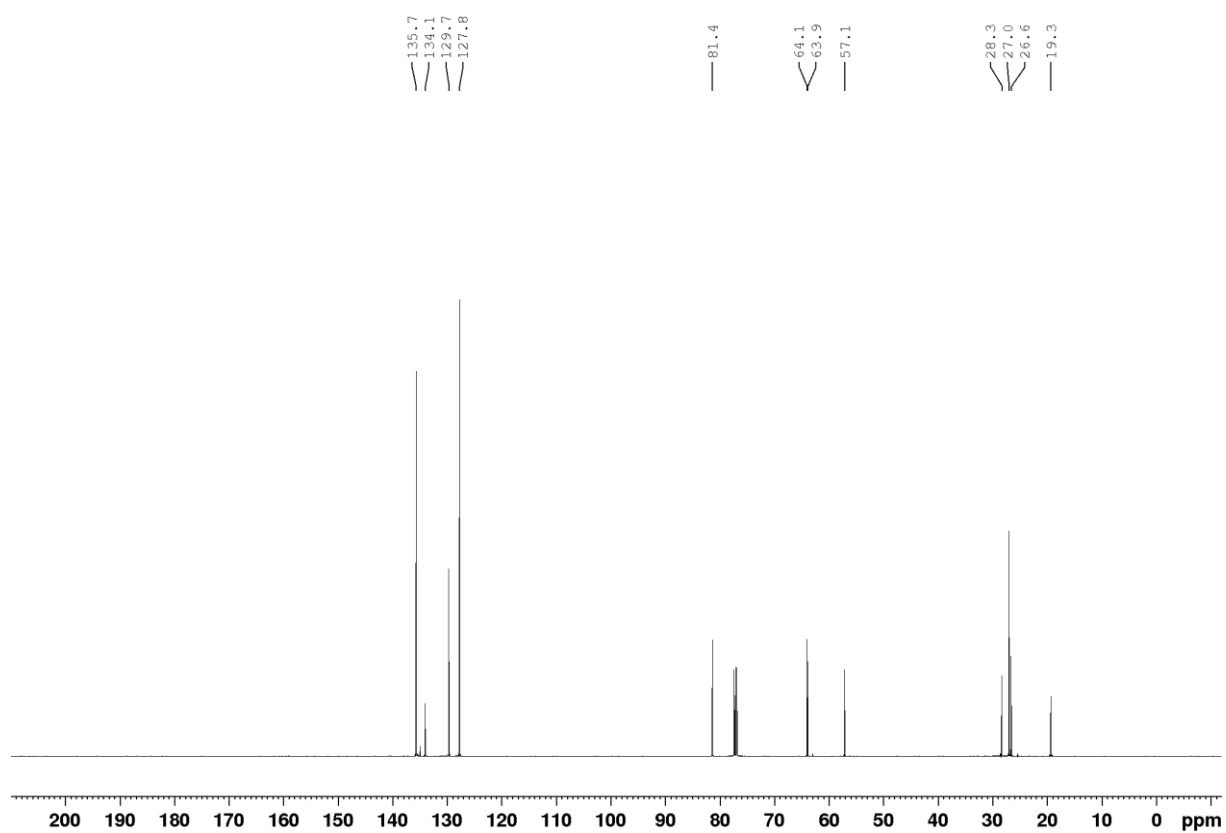
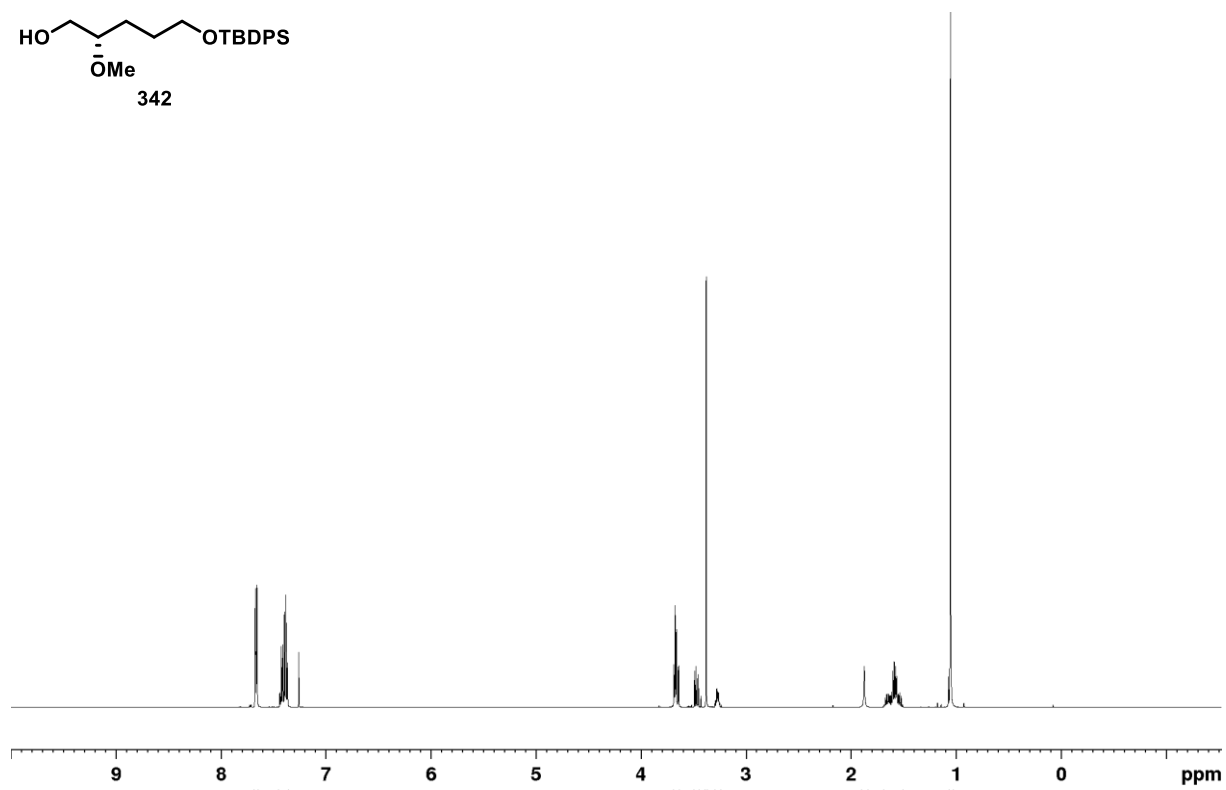
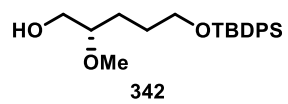

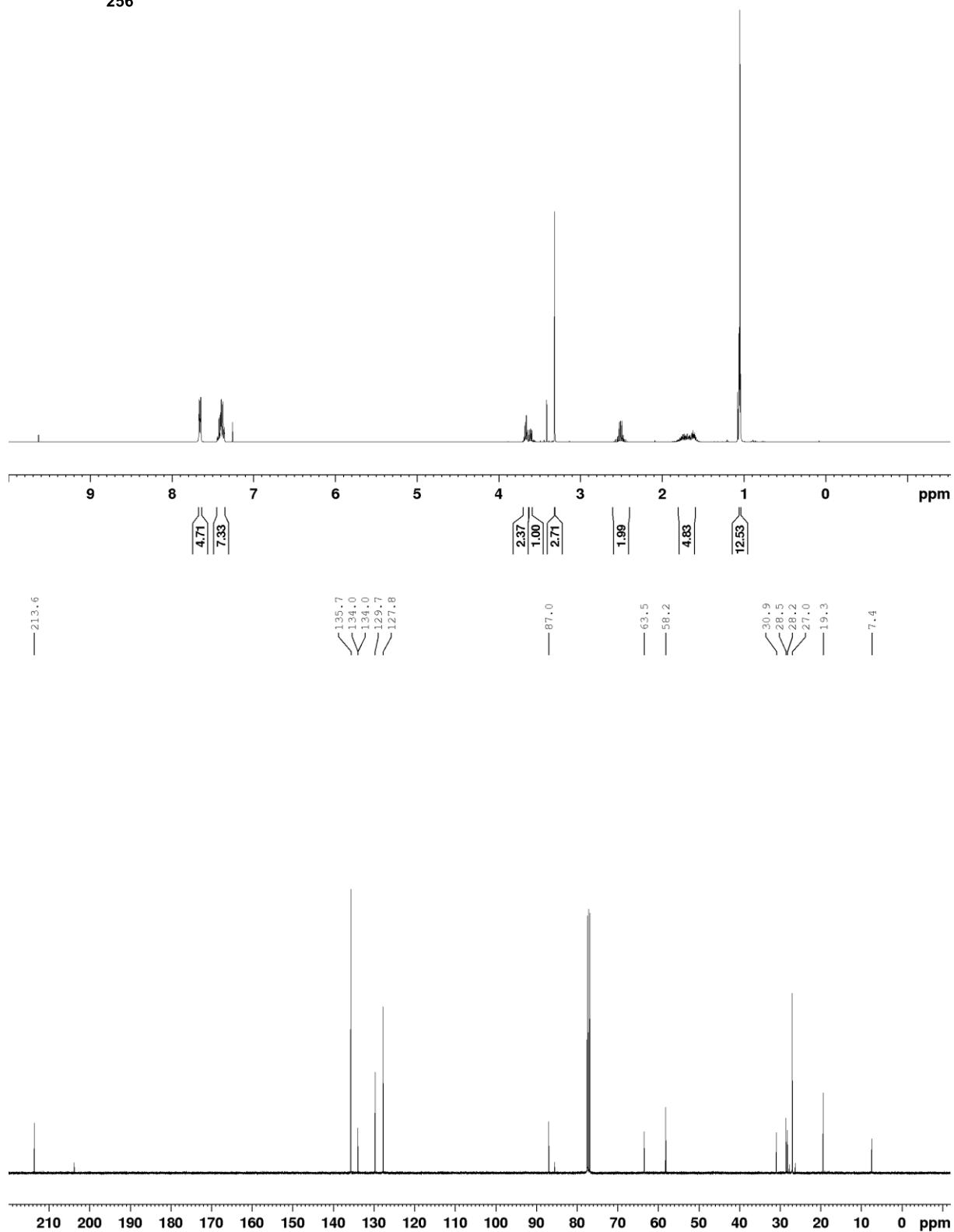
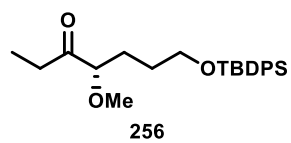

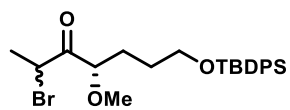

257 (crude)

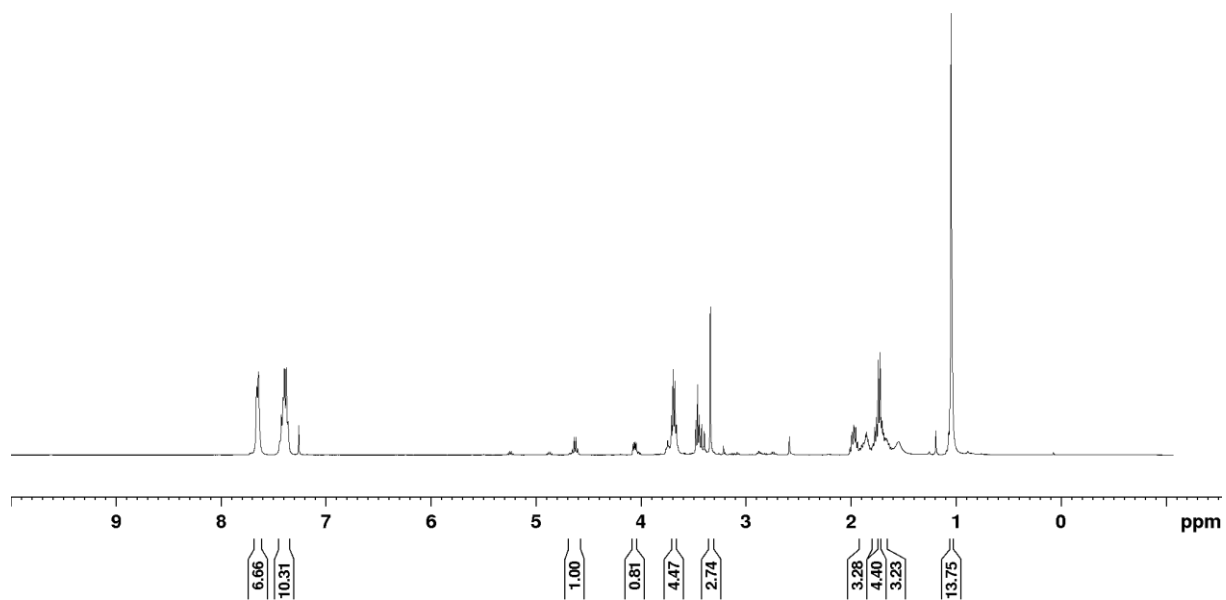

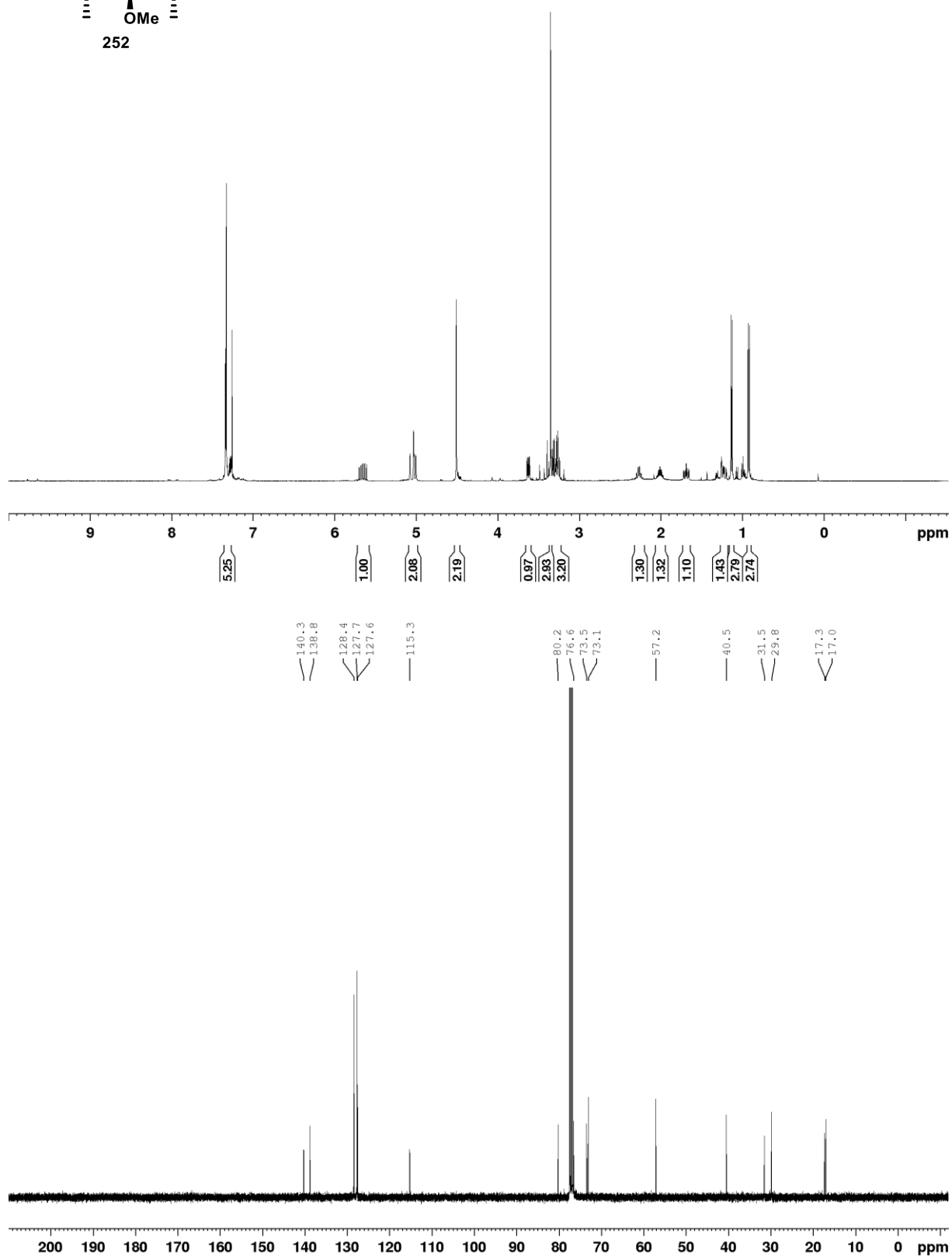
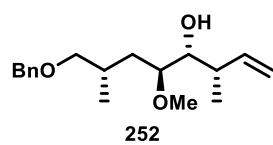





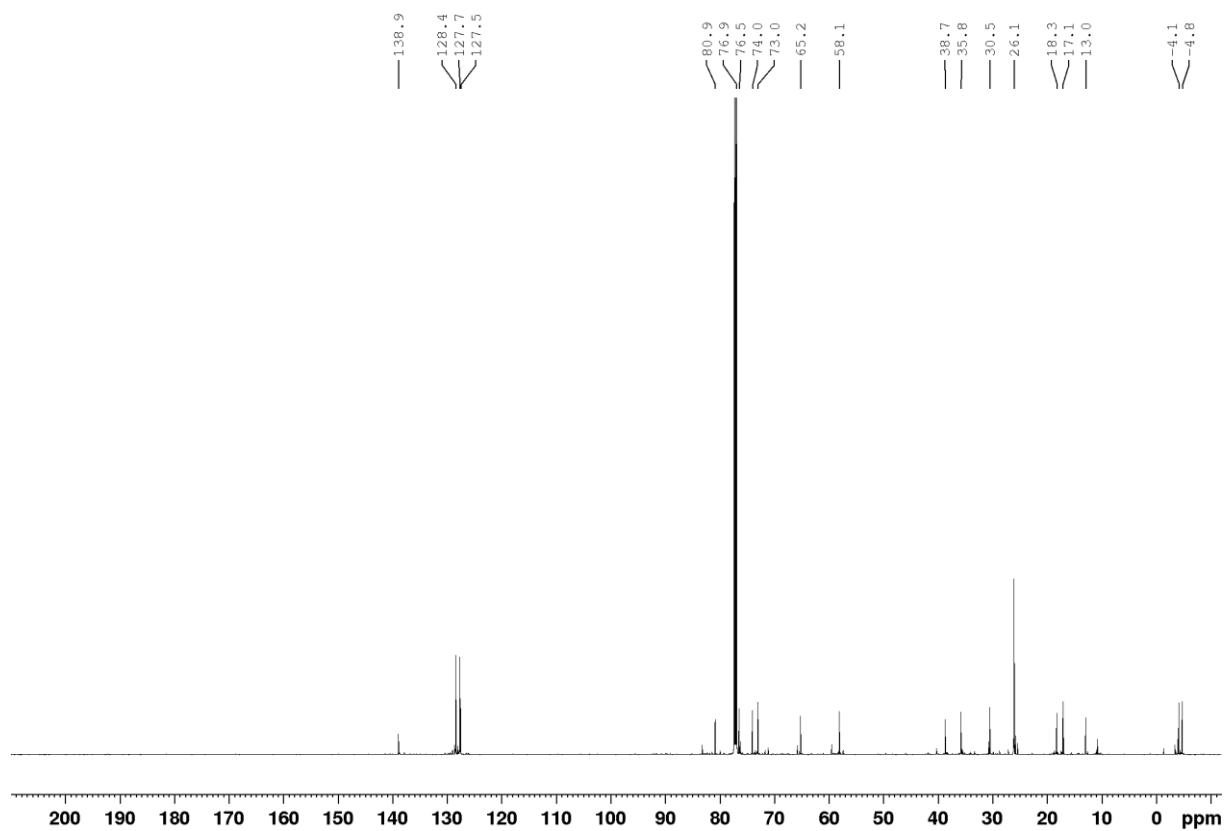
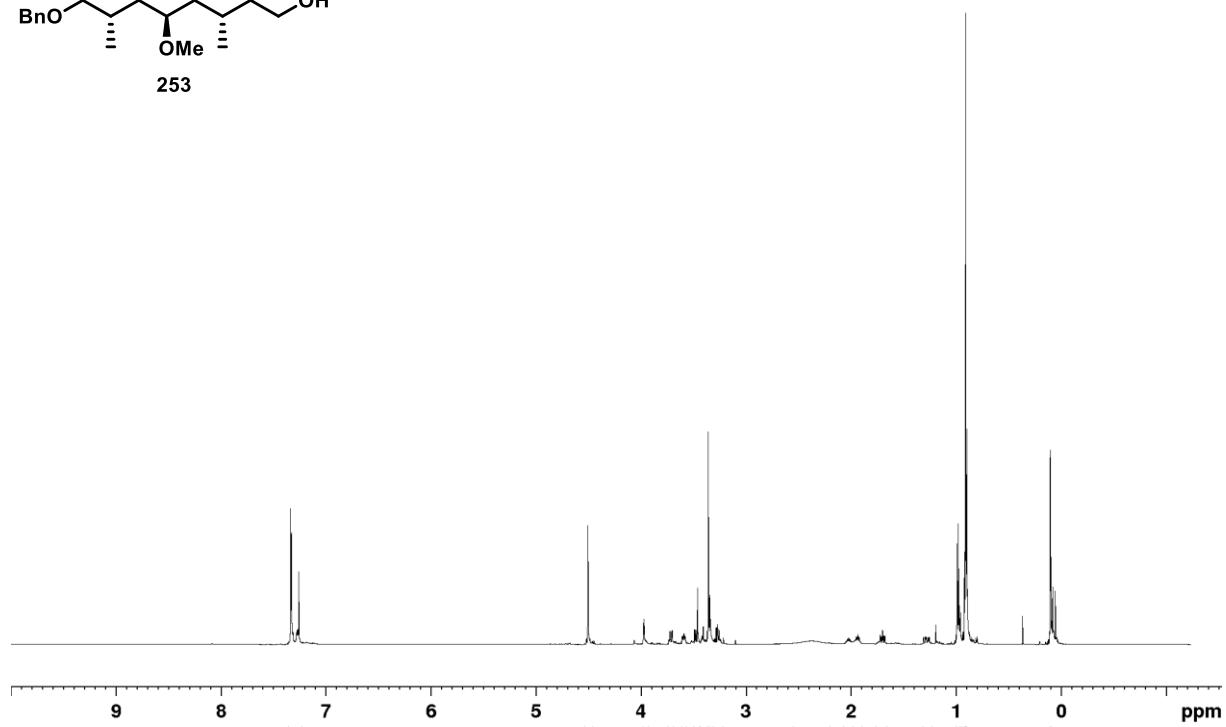
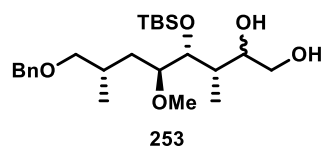

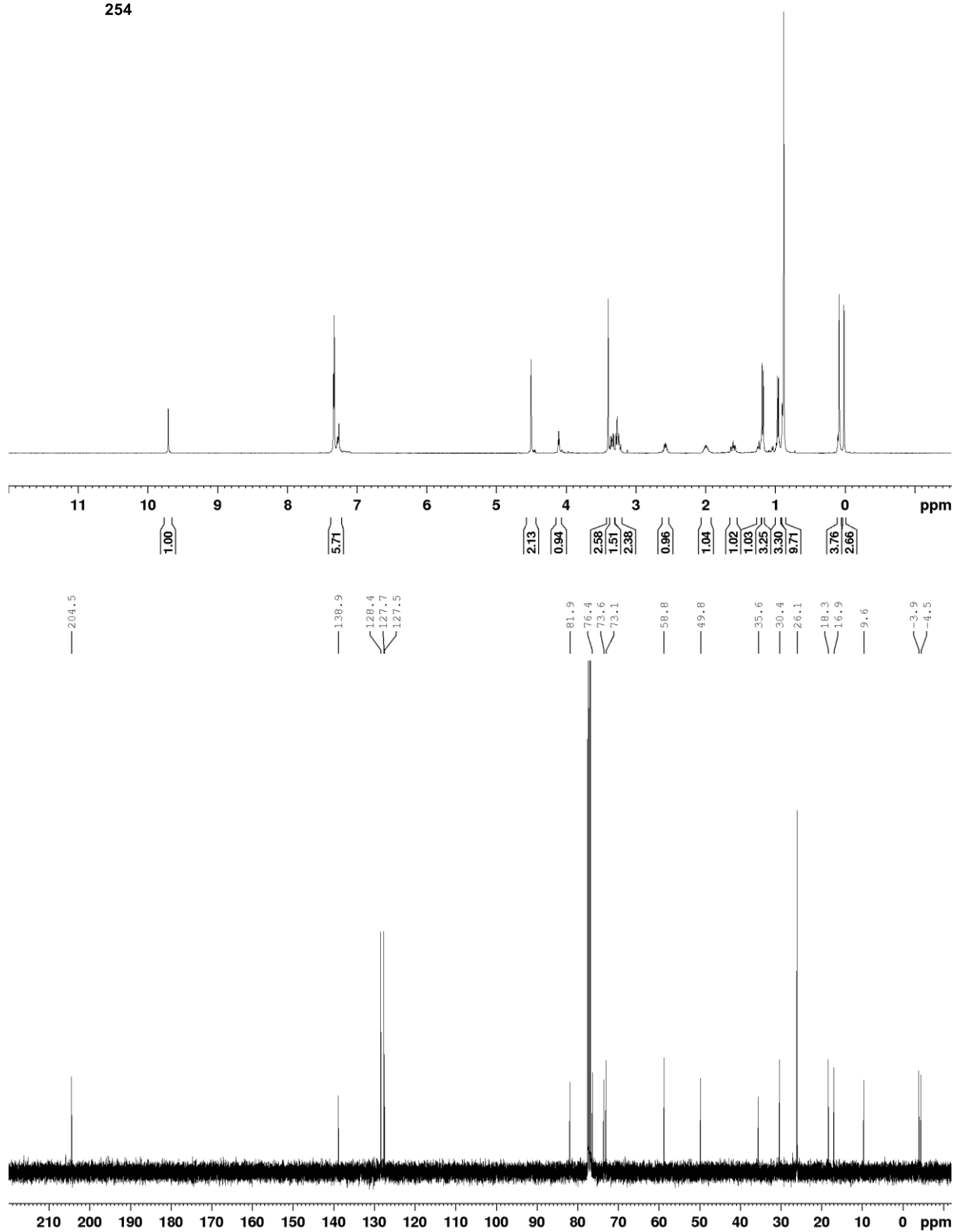
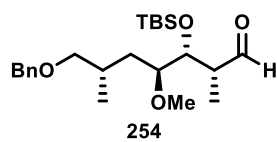

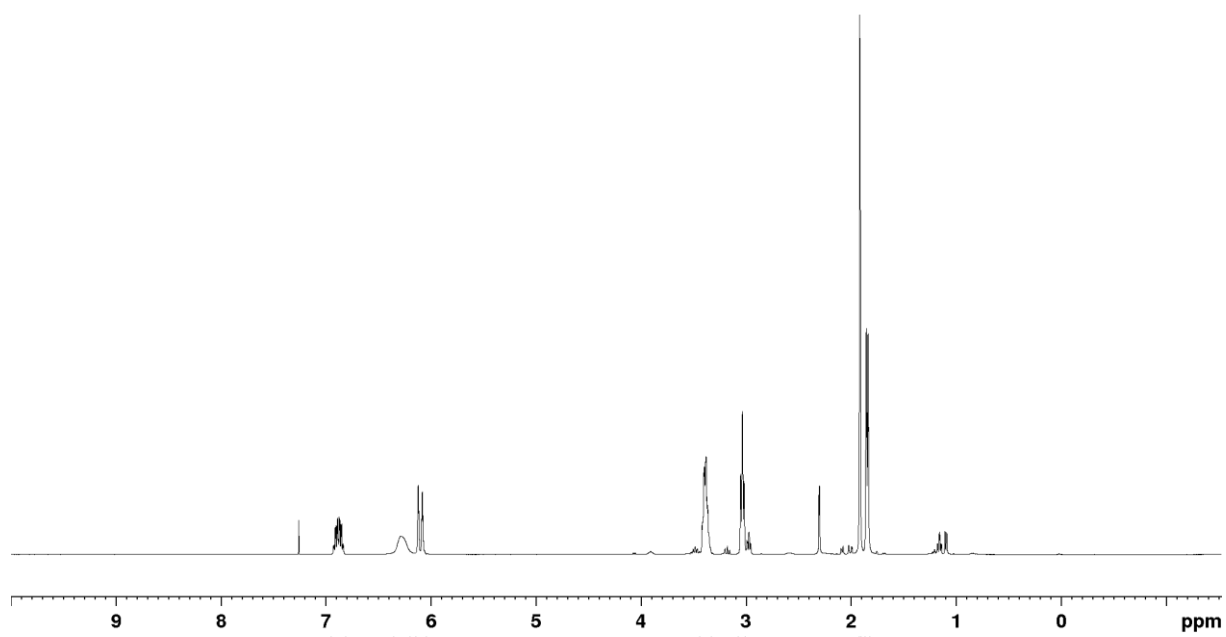
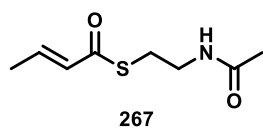

190.0  
190.0

170.5

141.7

129.9

39.7

28.1

23.1

18.0

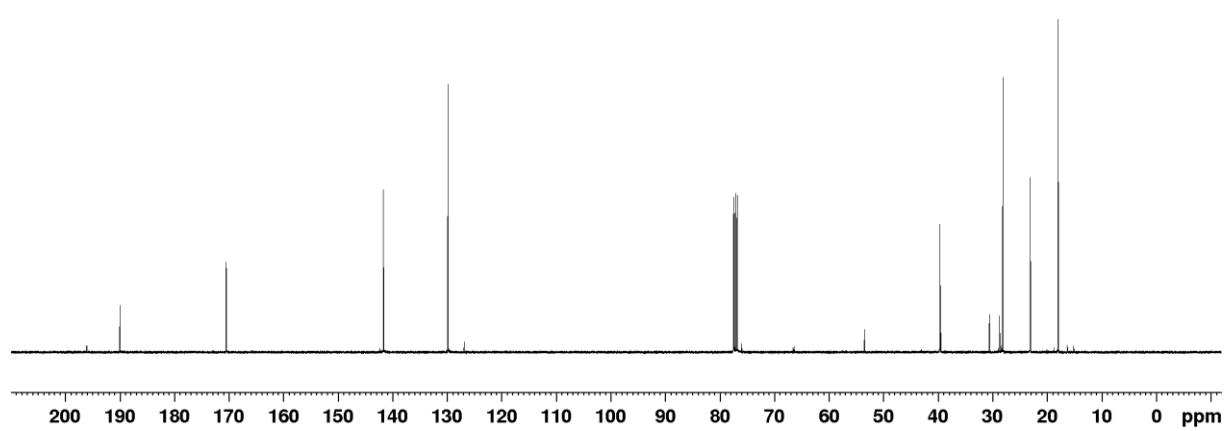

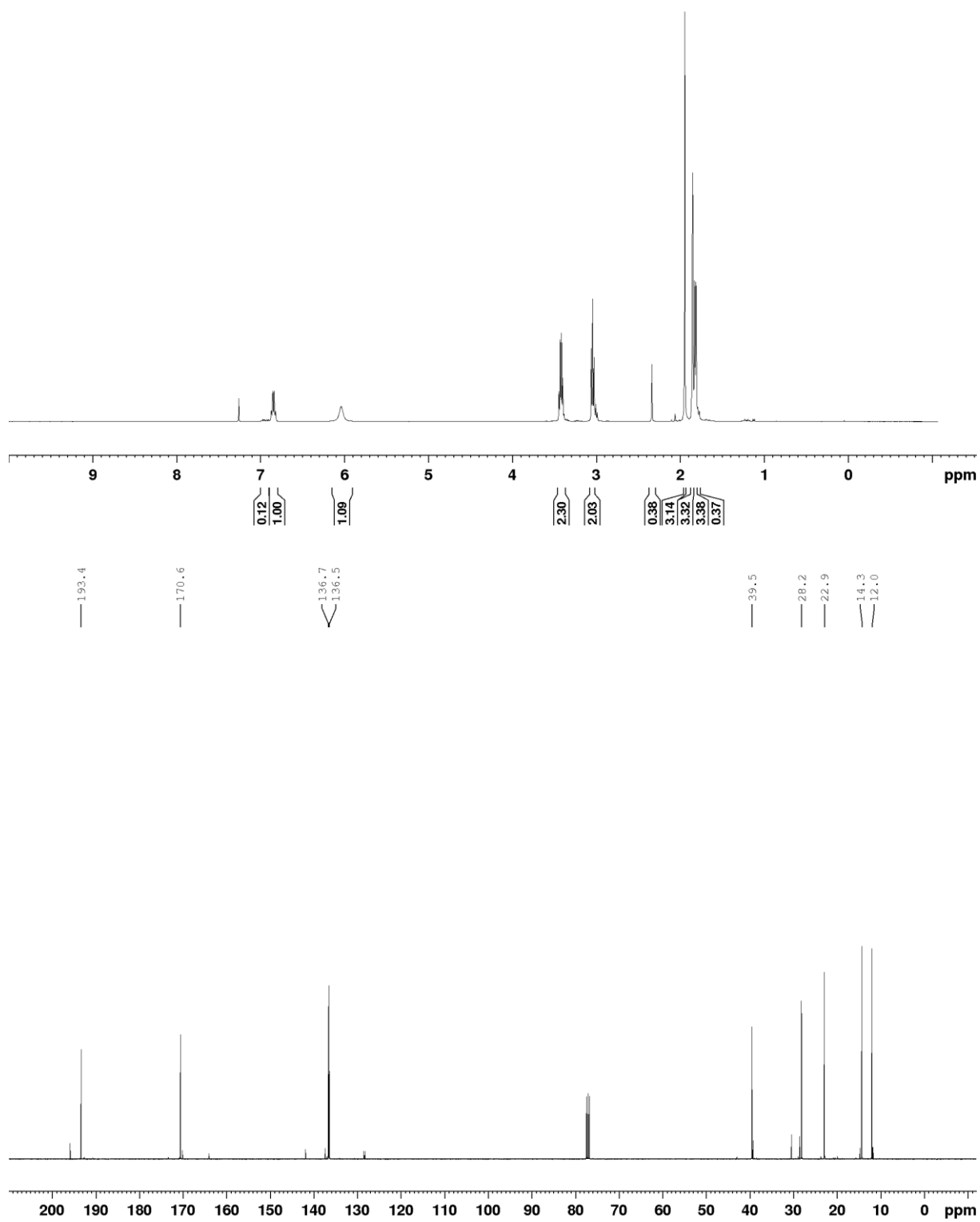
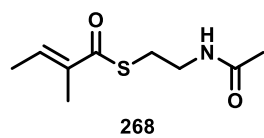

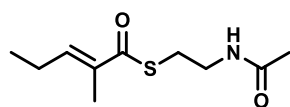

269

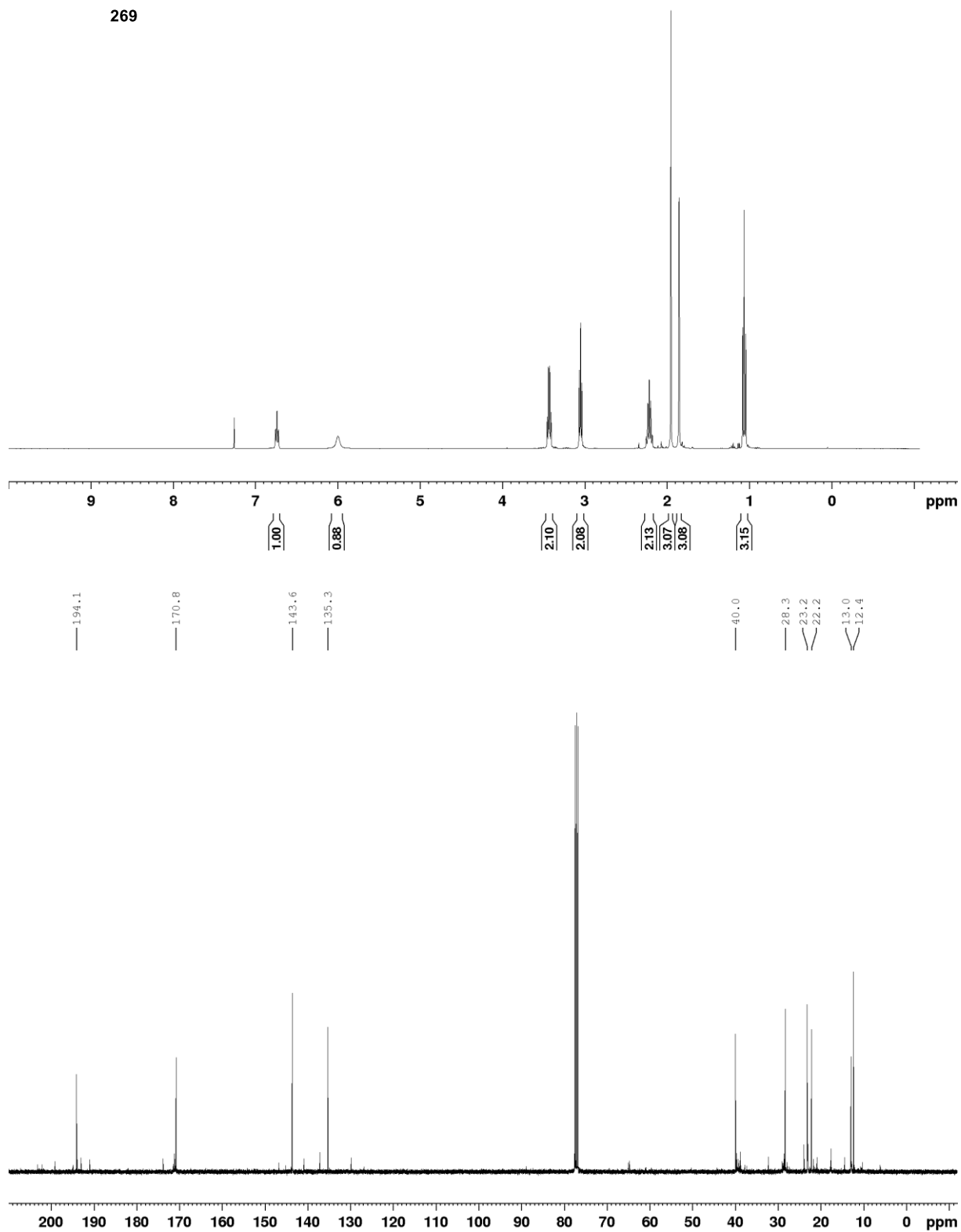

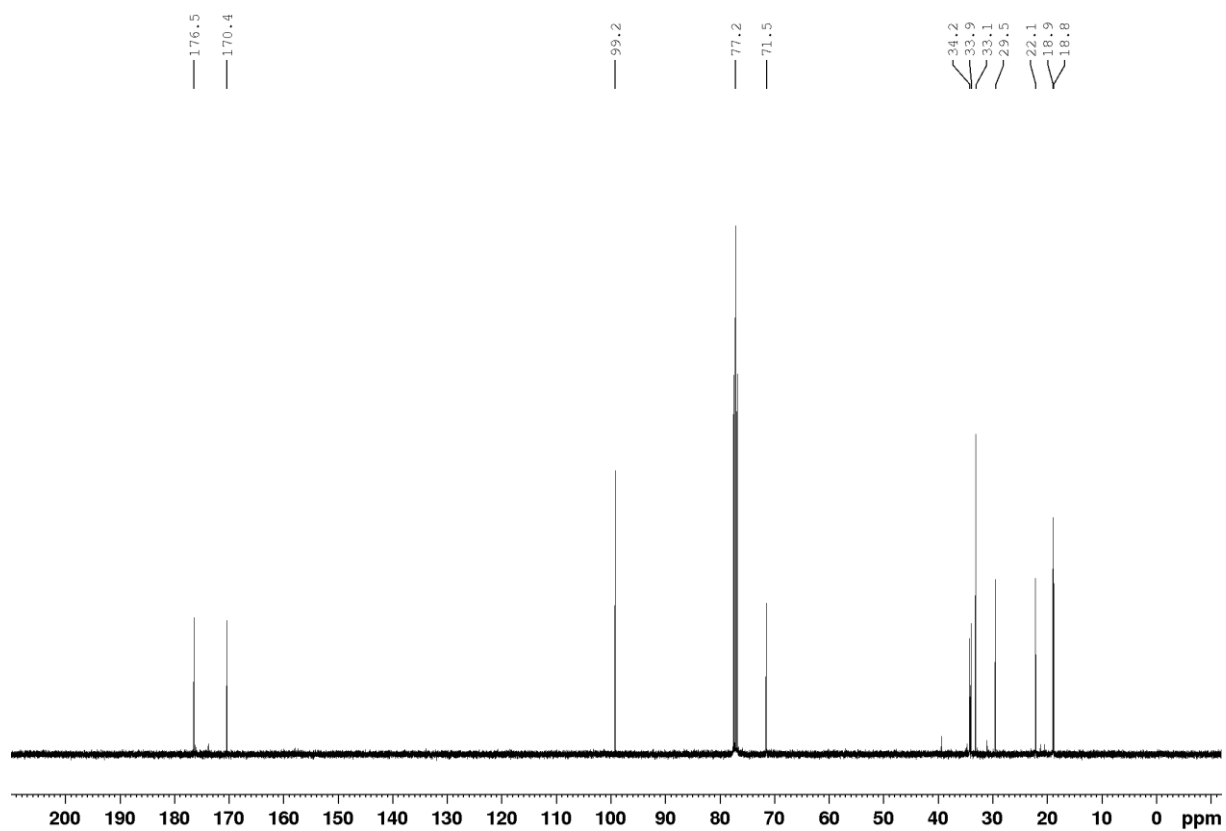
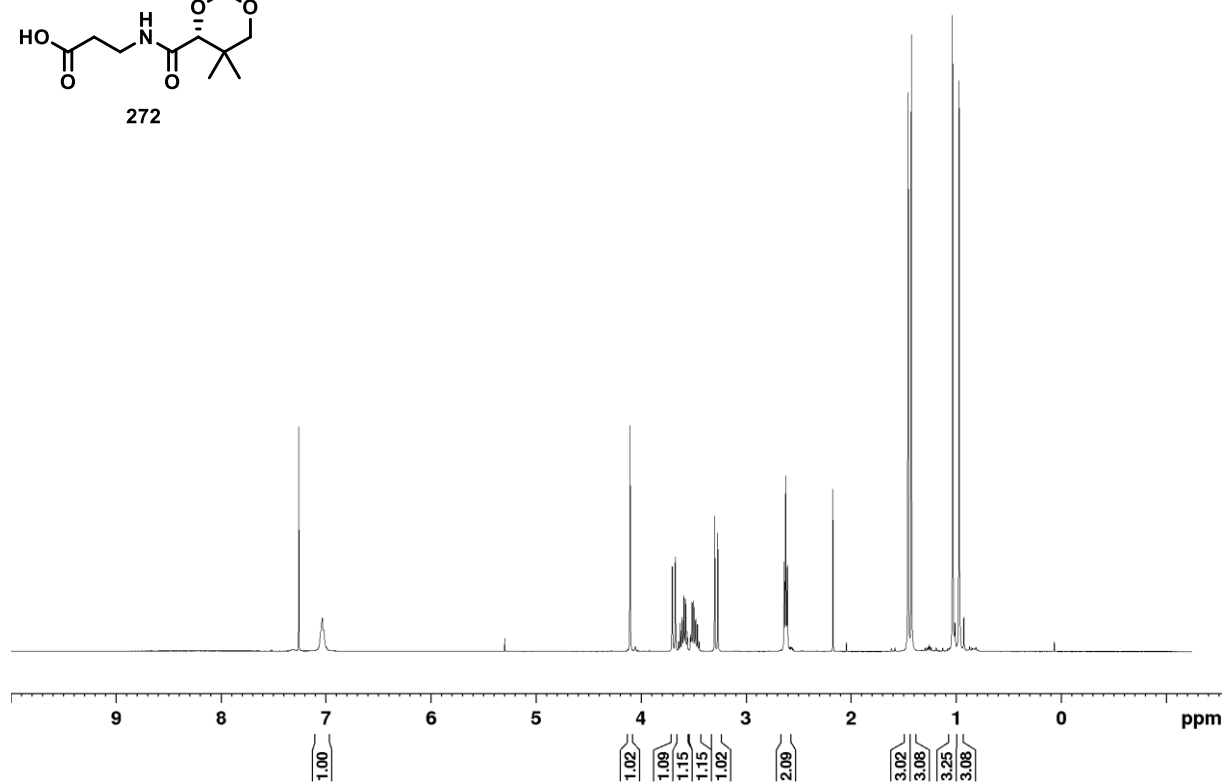
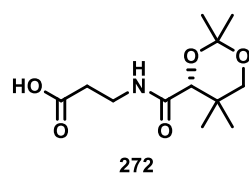

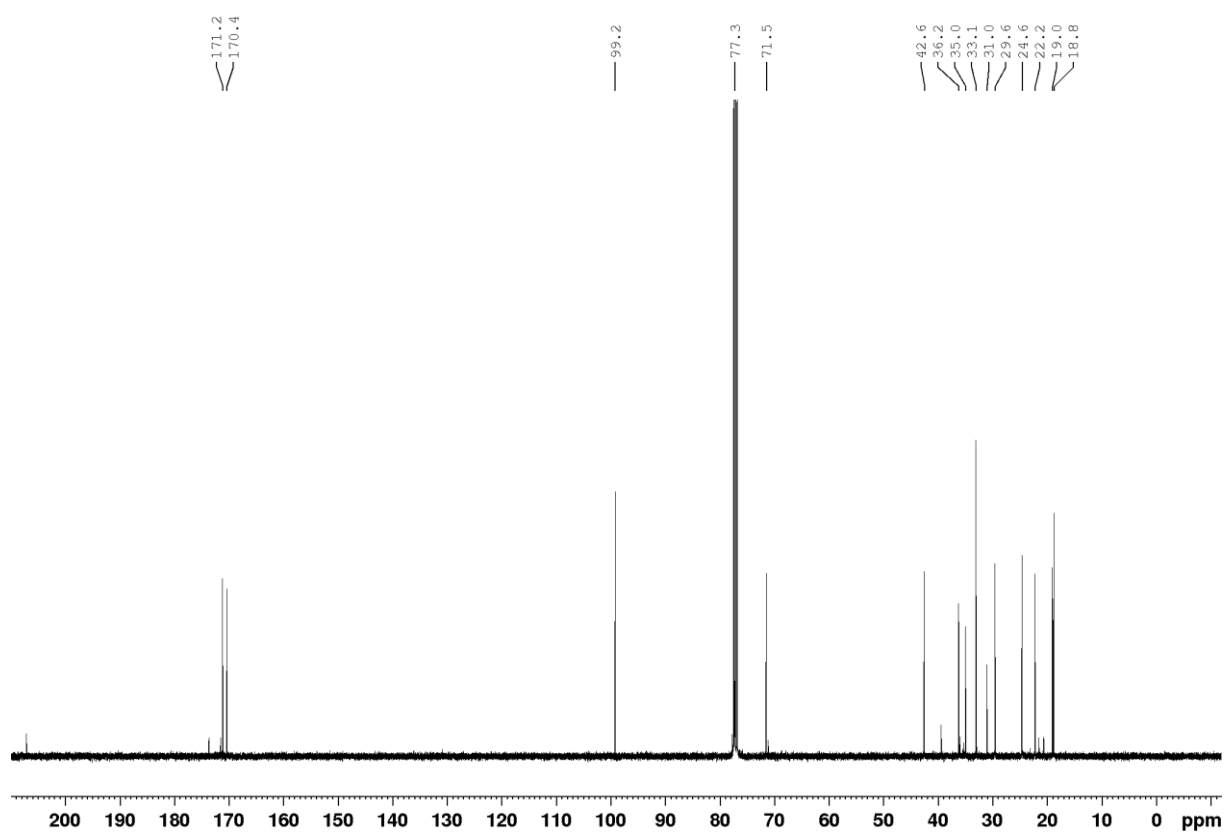
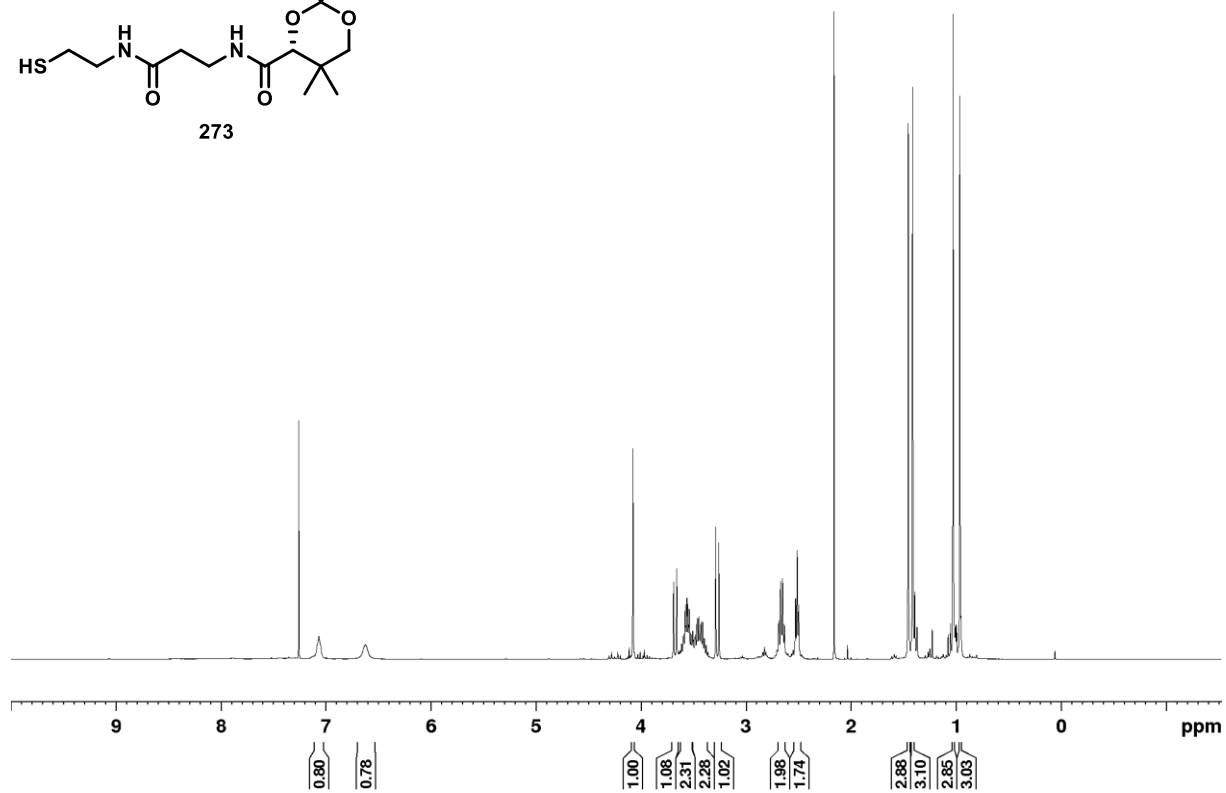
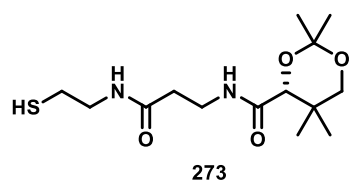



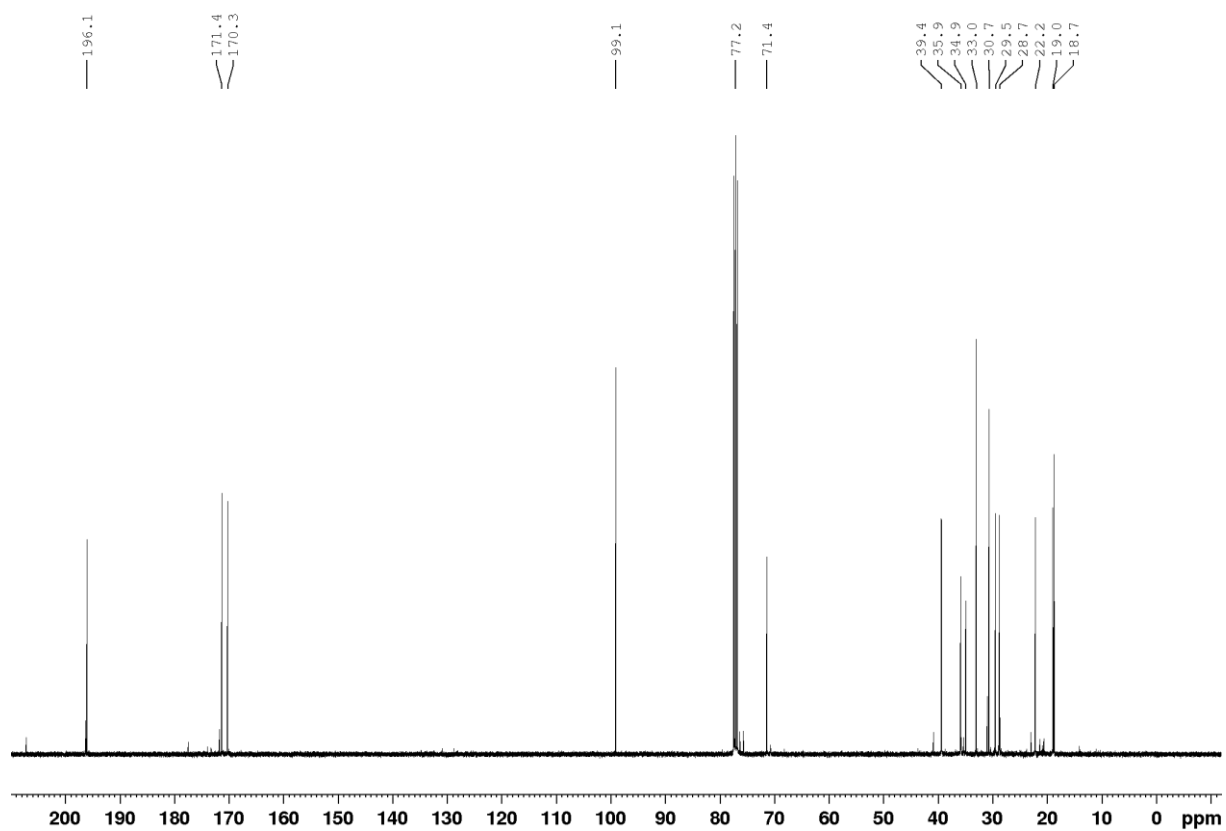
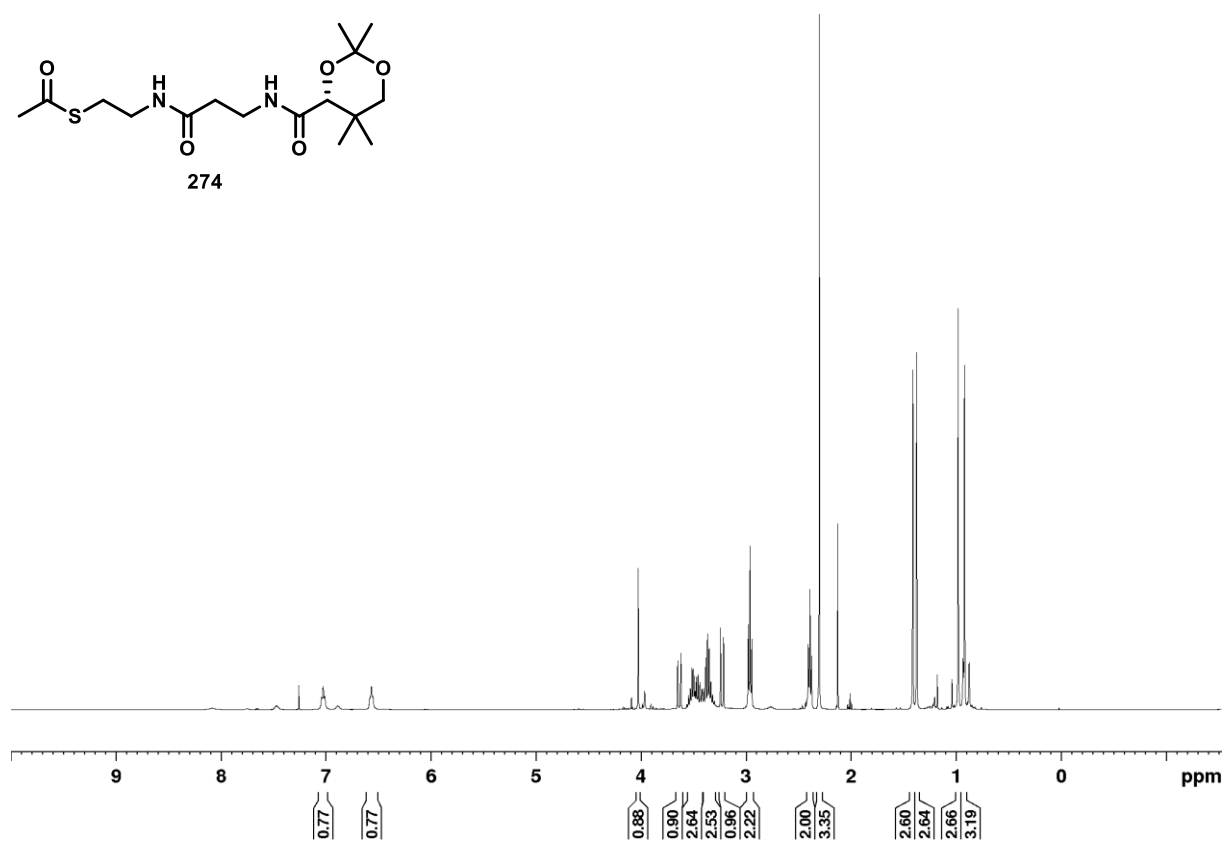
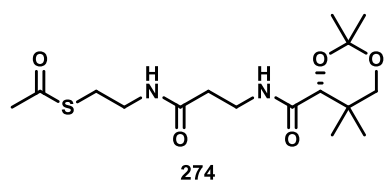

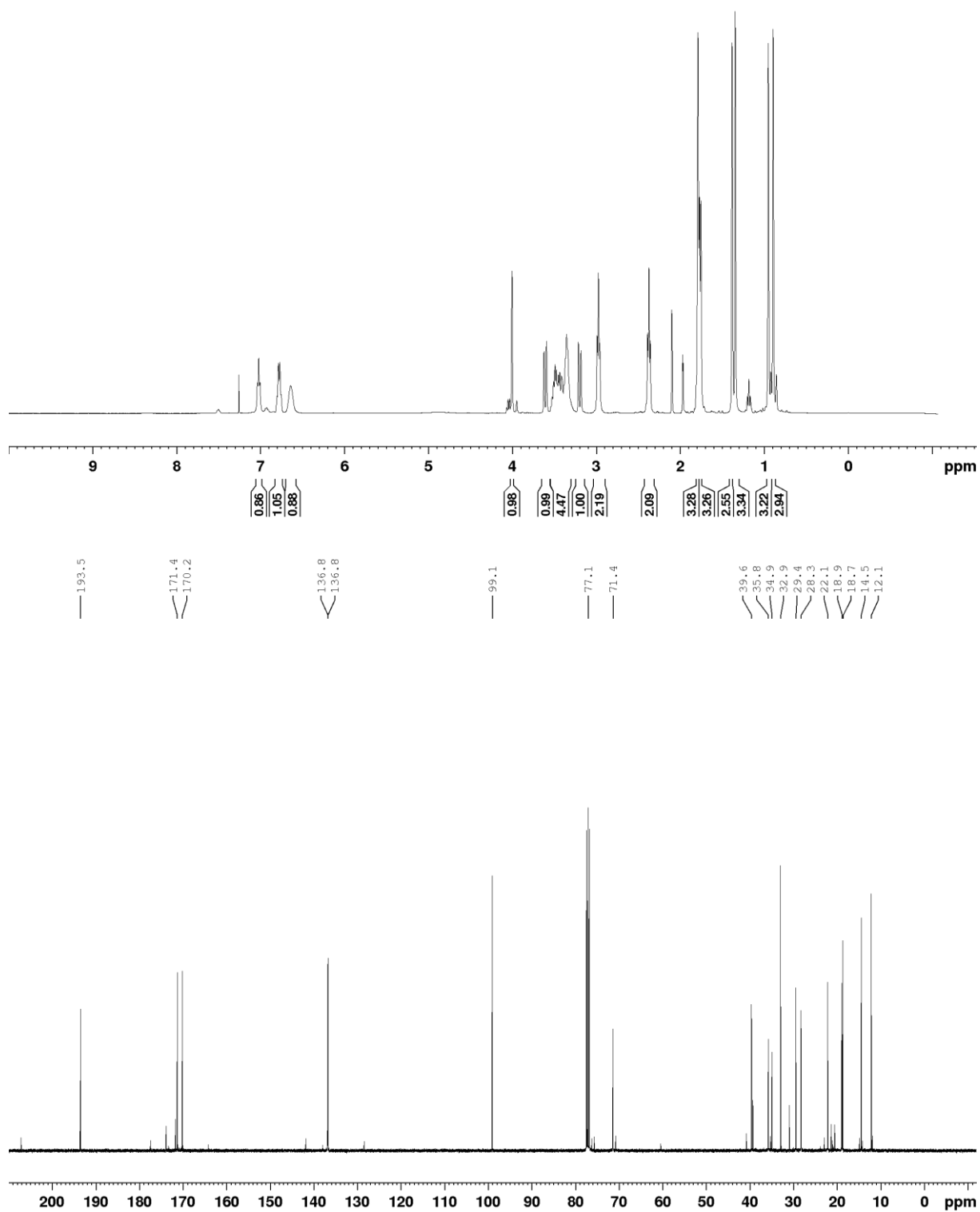
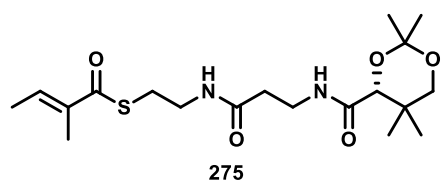

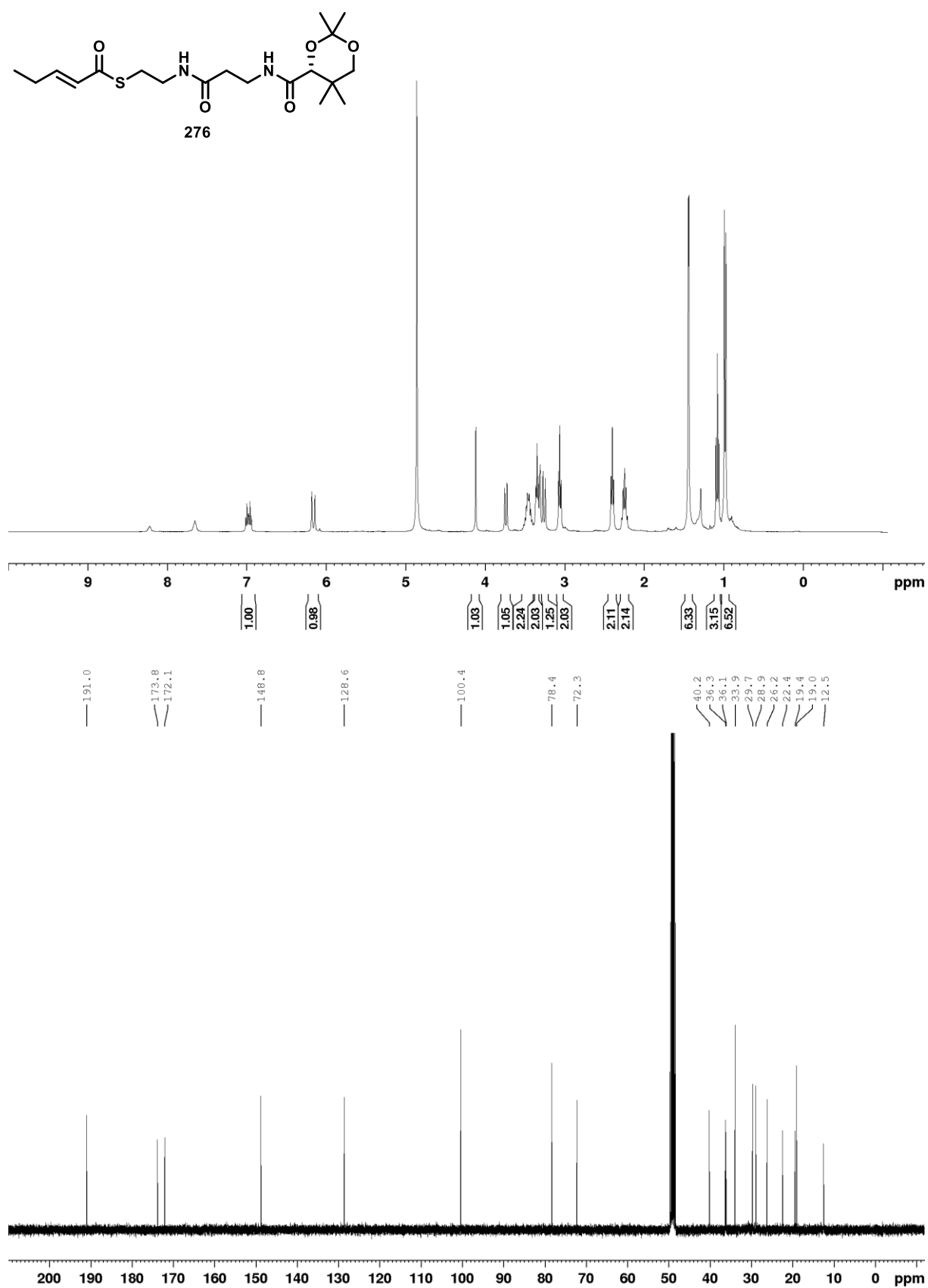

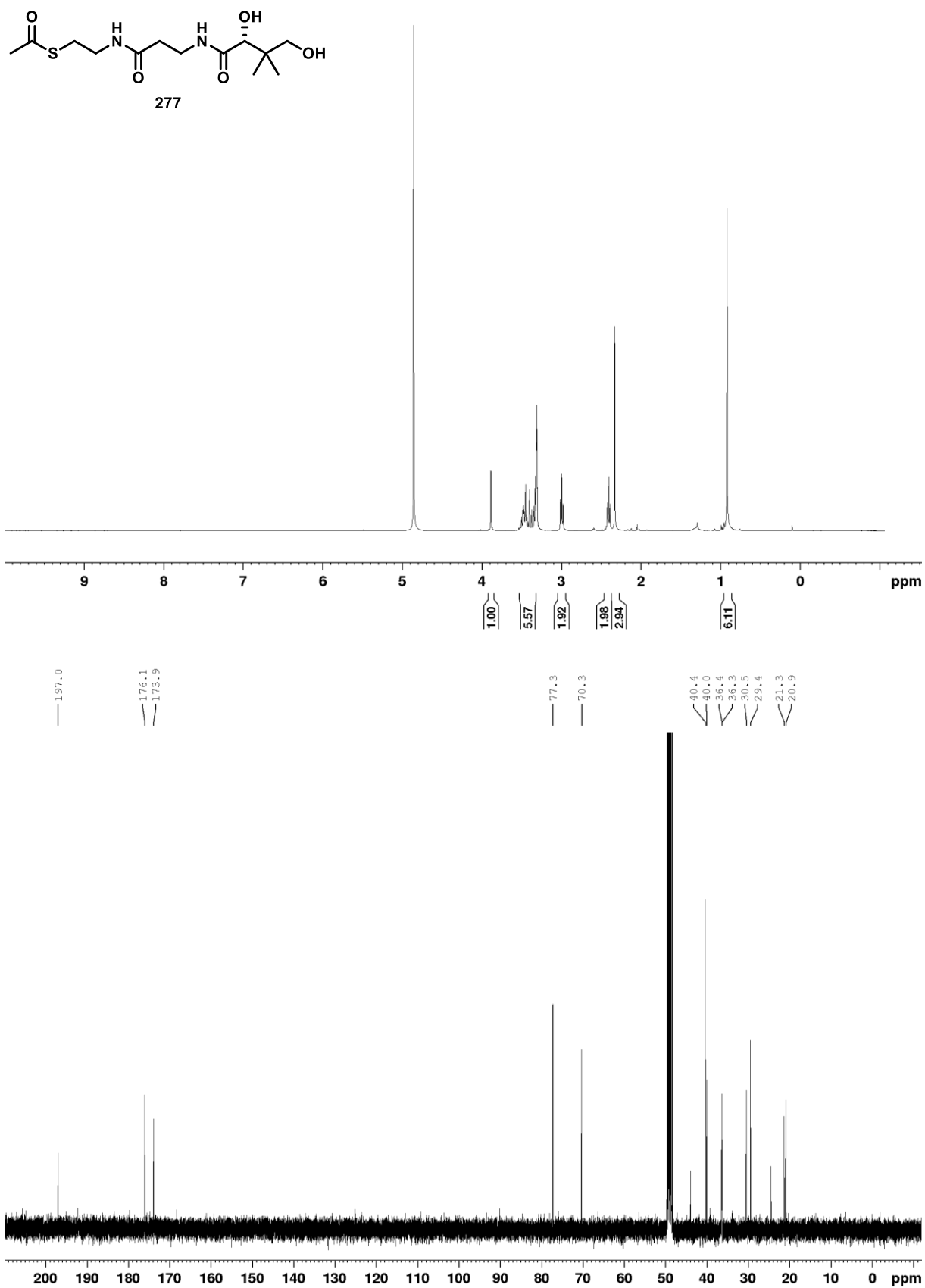

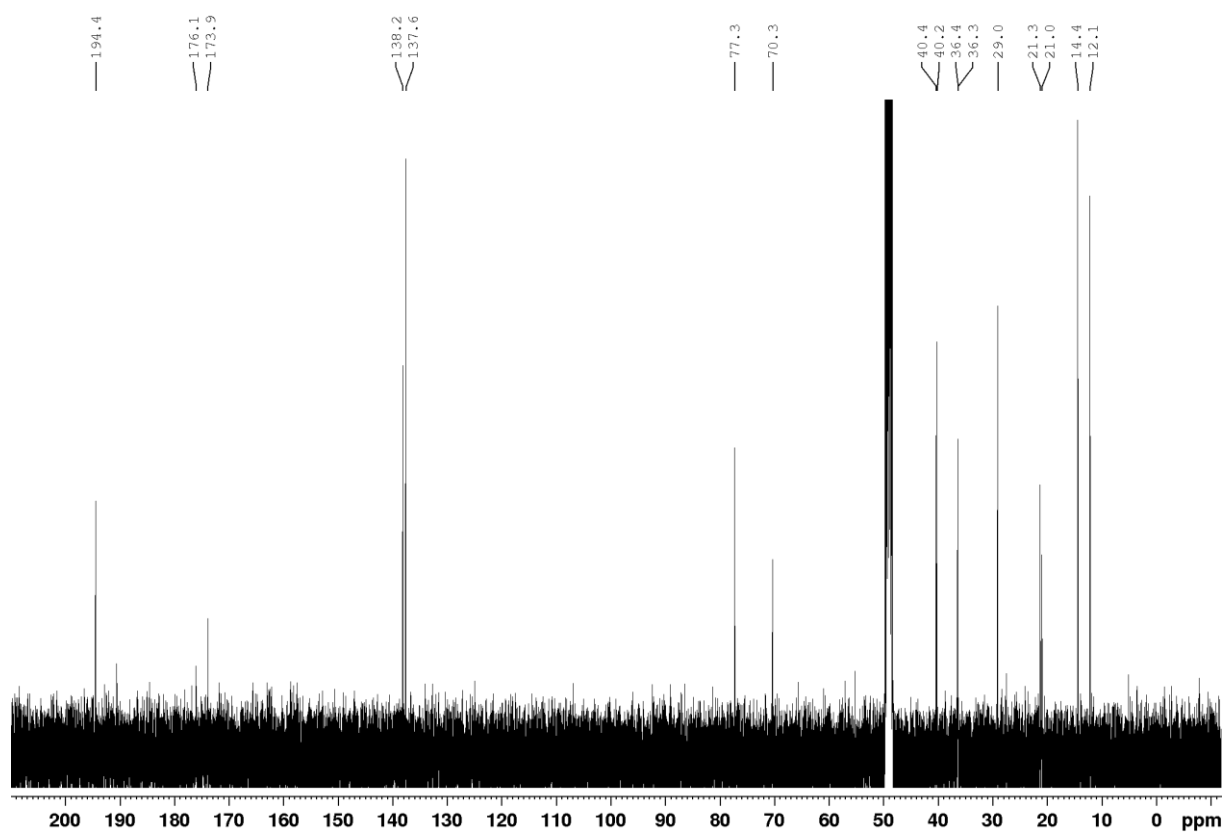
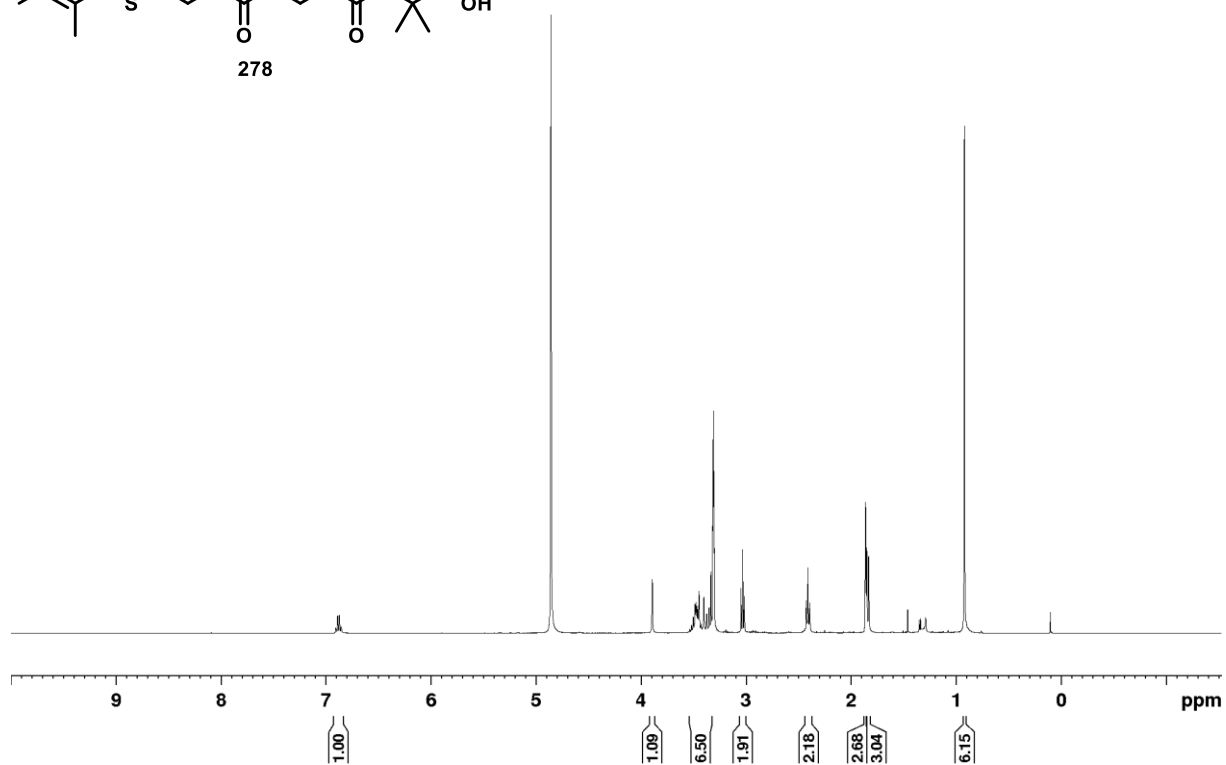
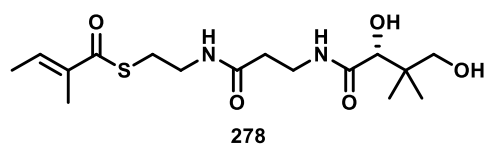

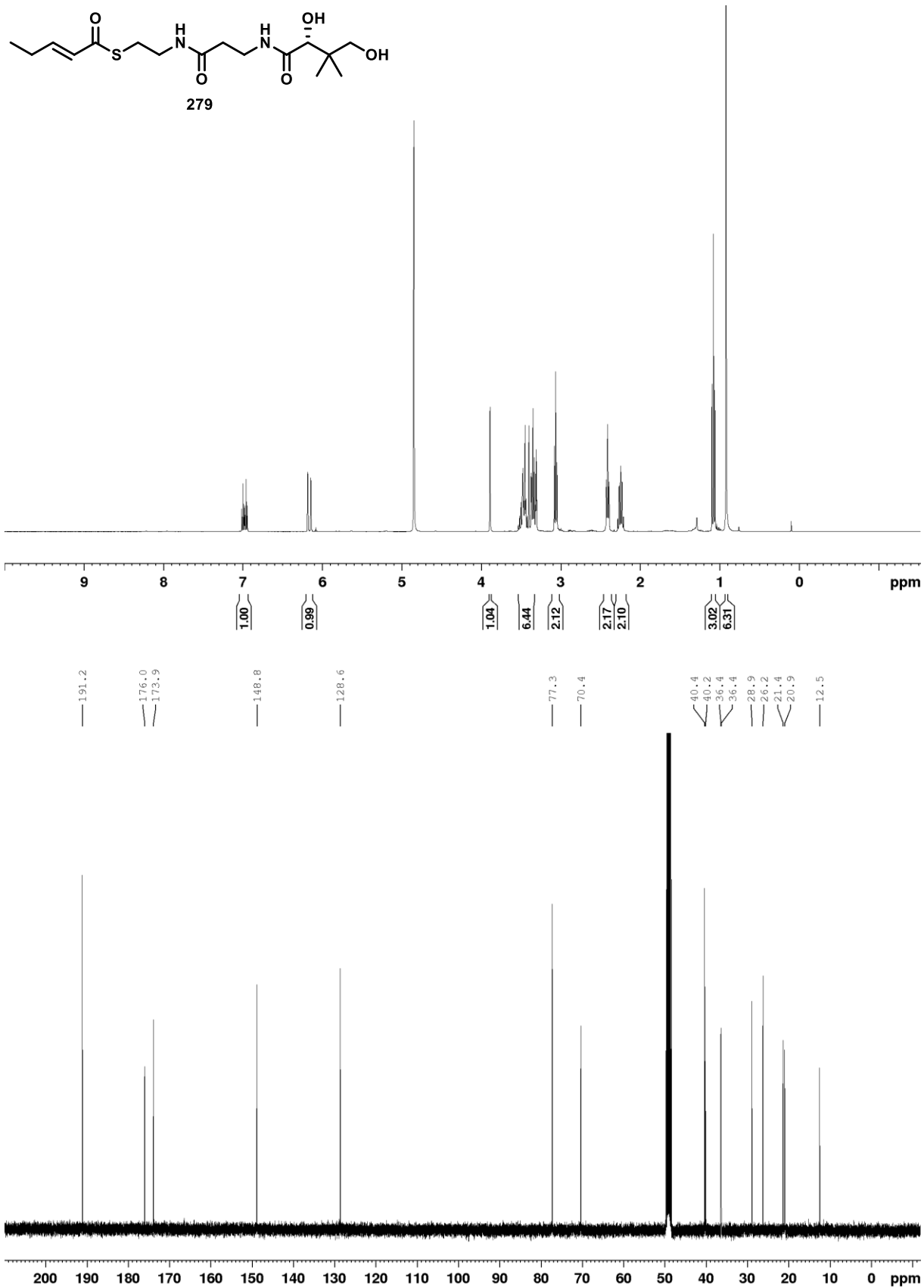

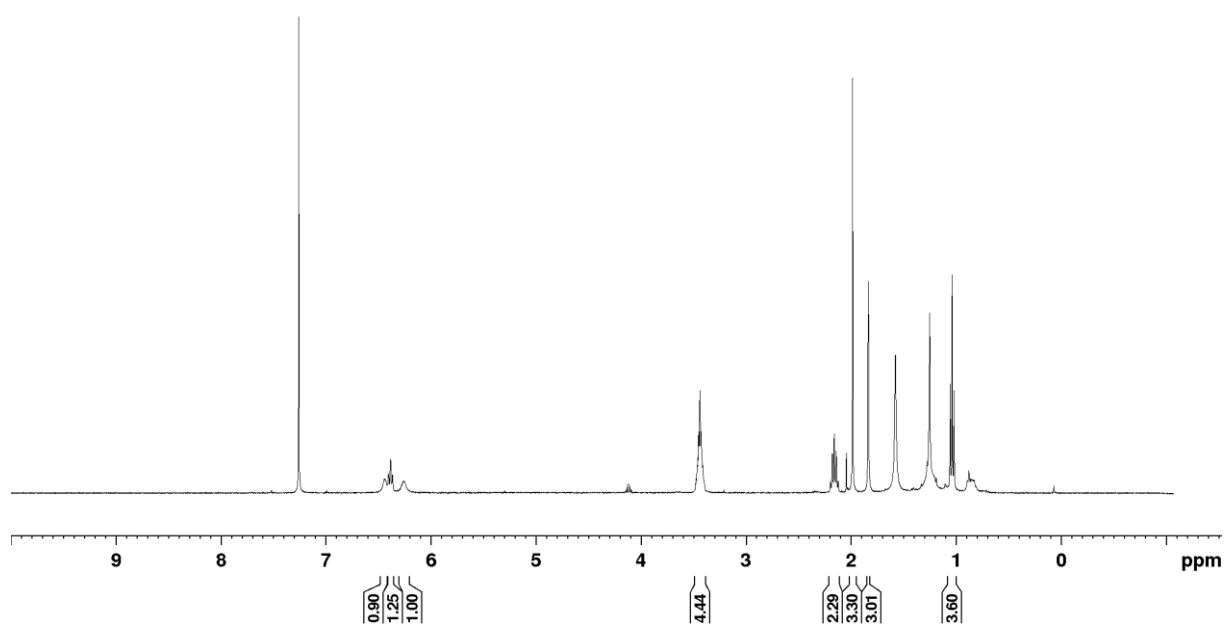
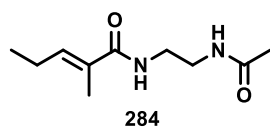
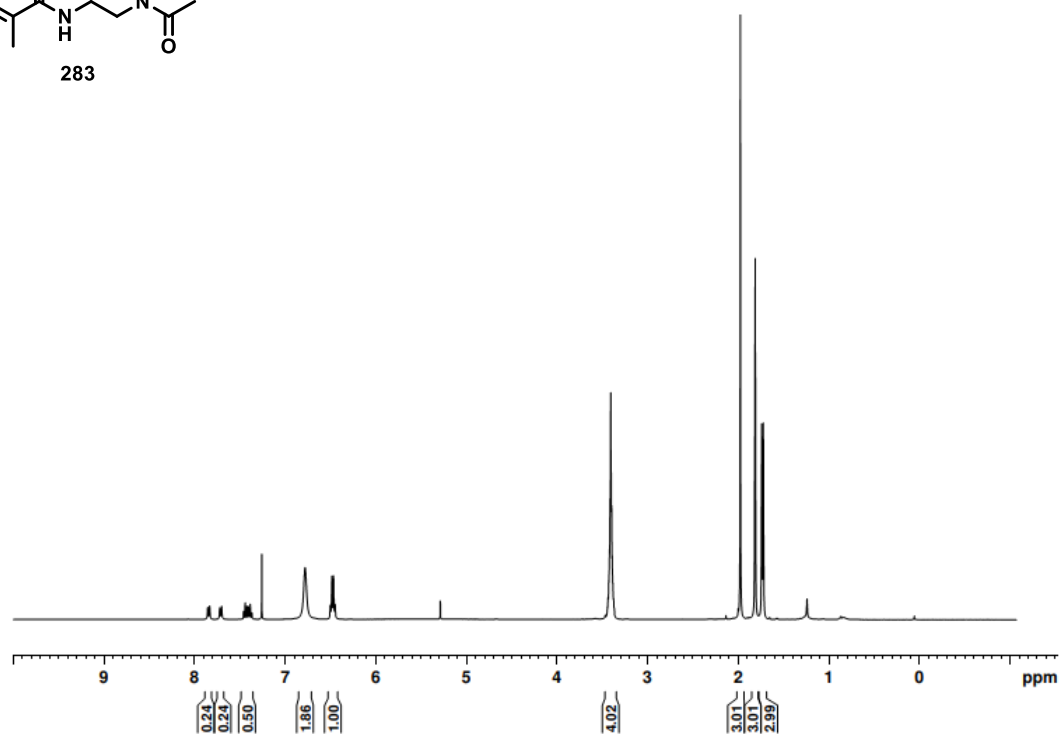
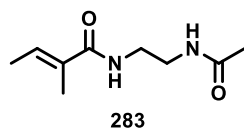

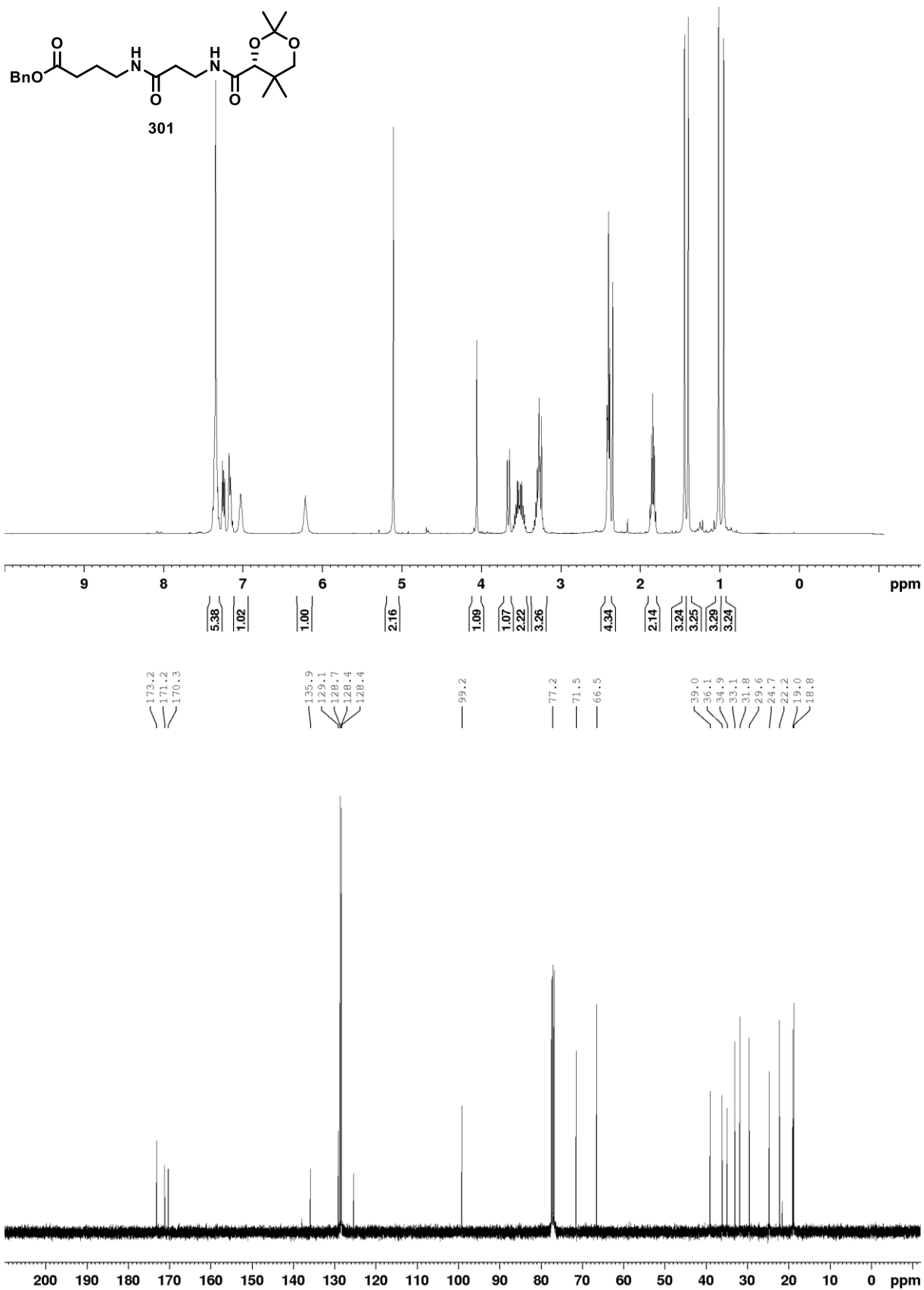



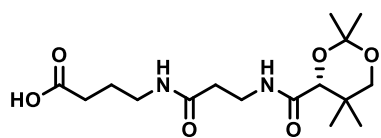

290

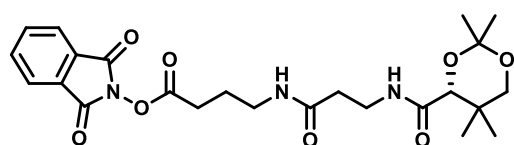
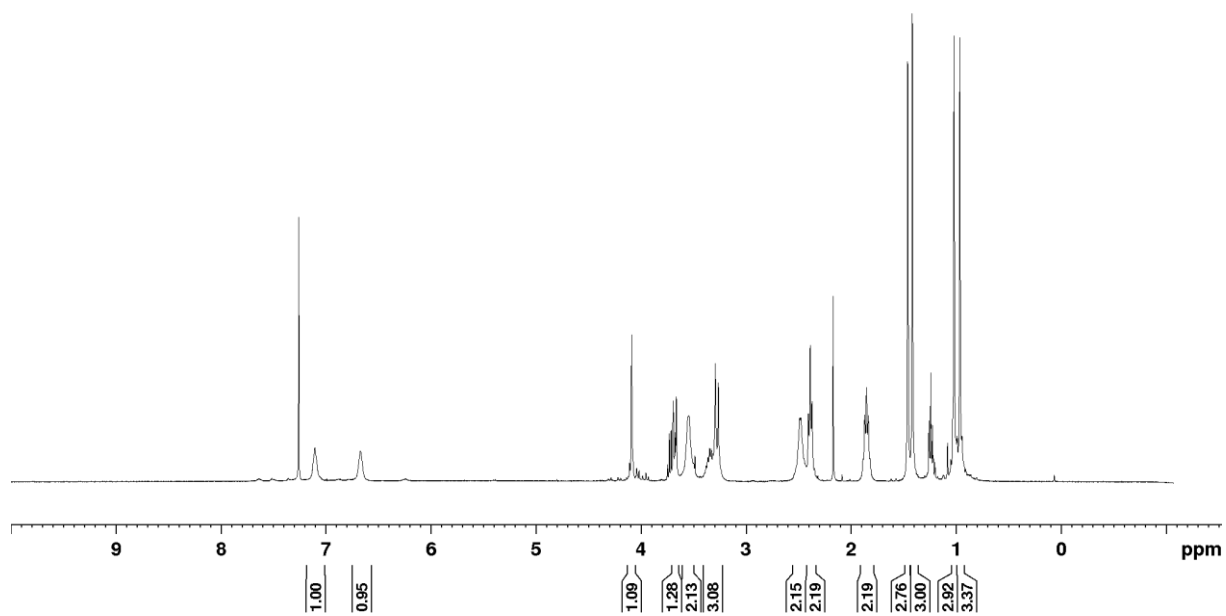

289

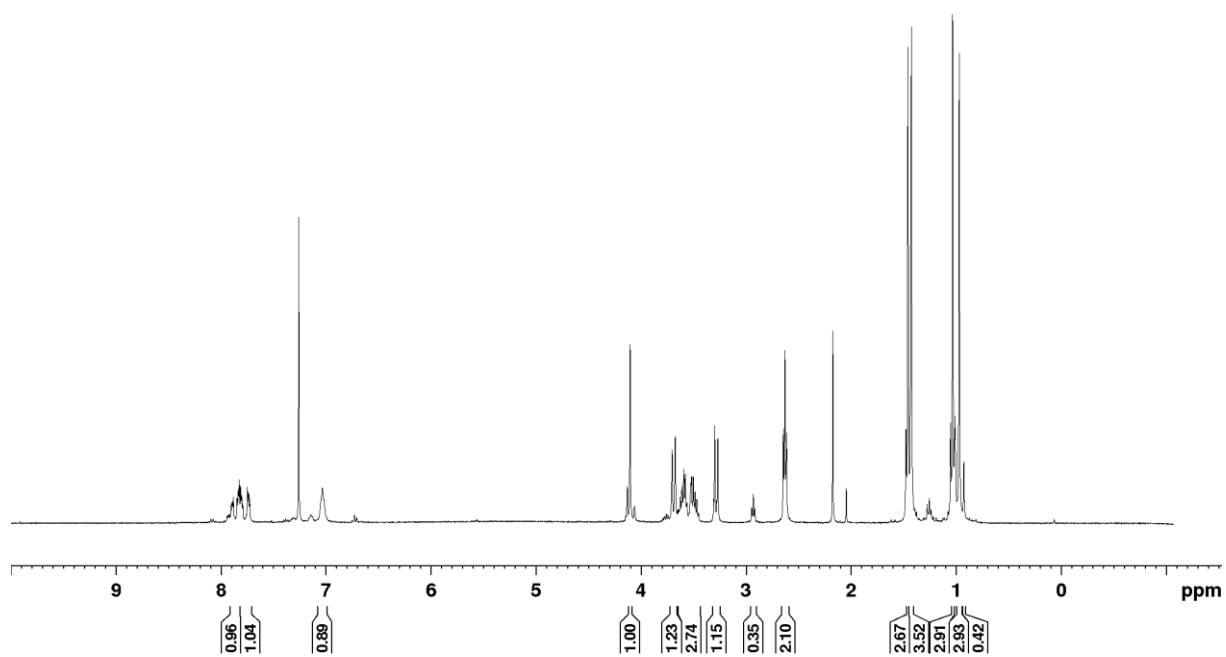

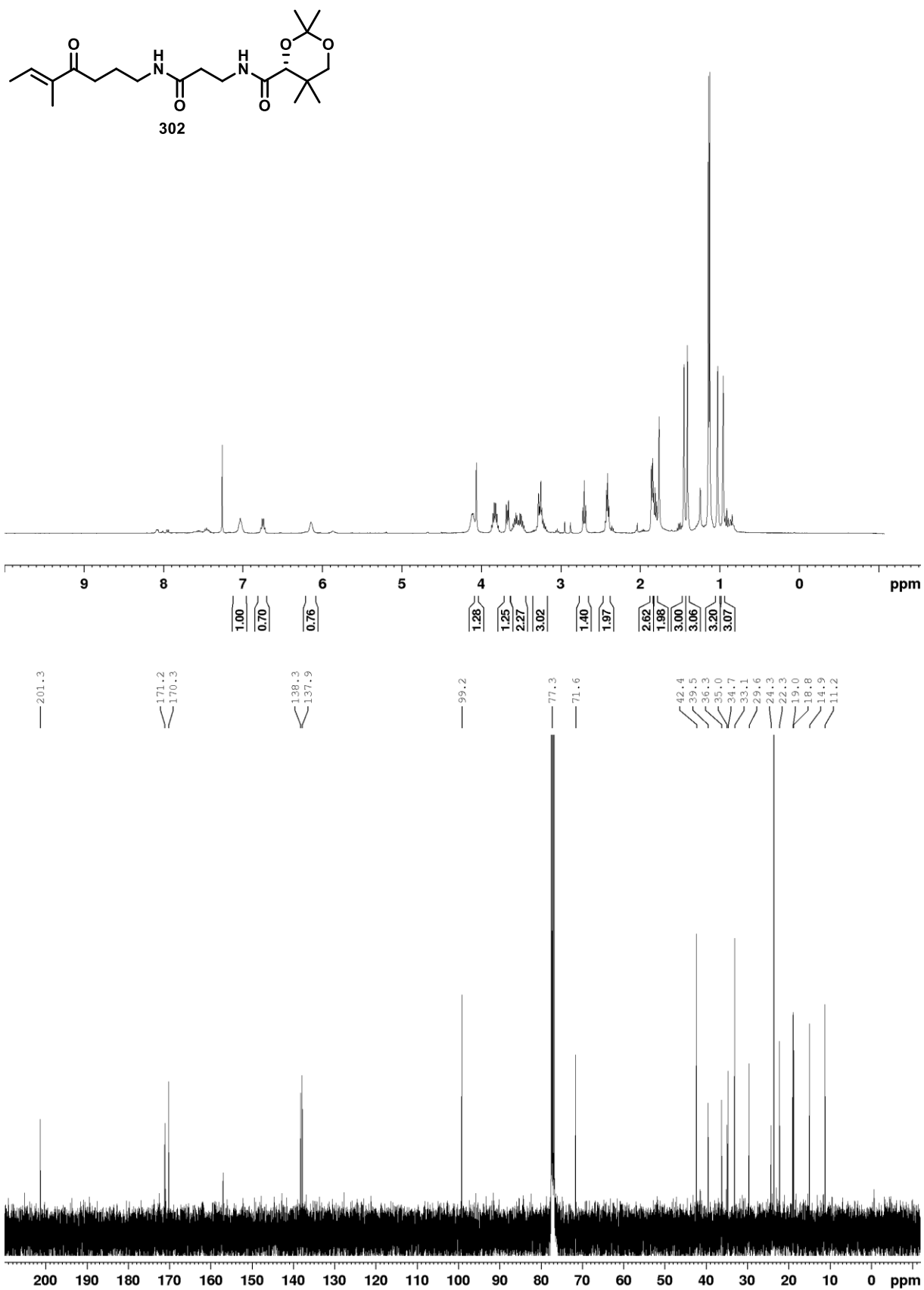

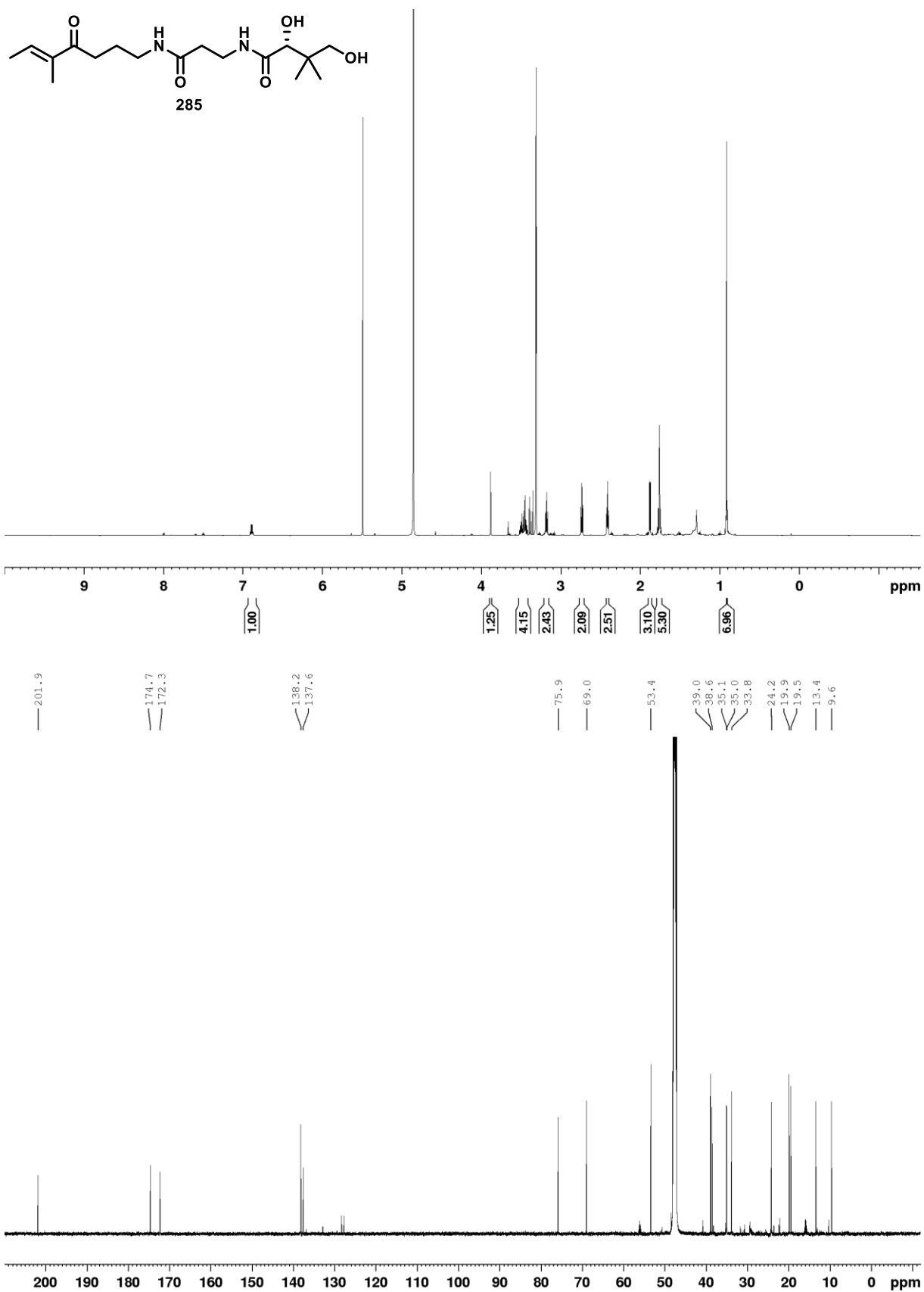

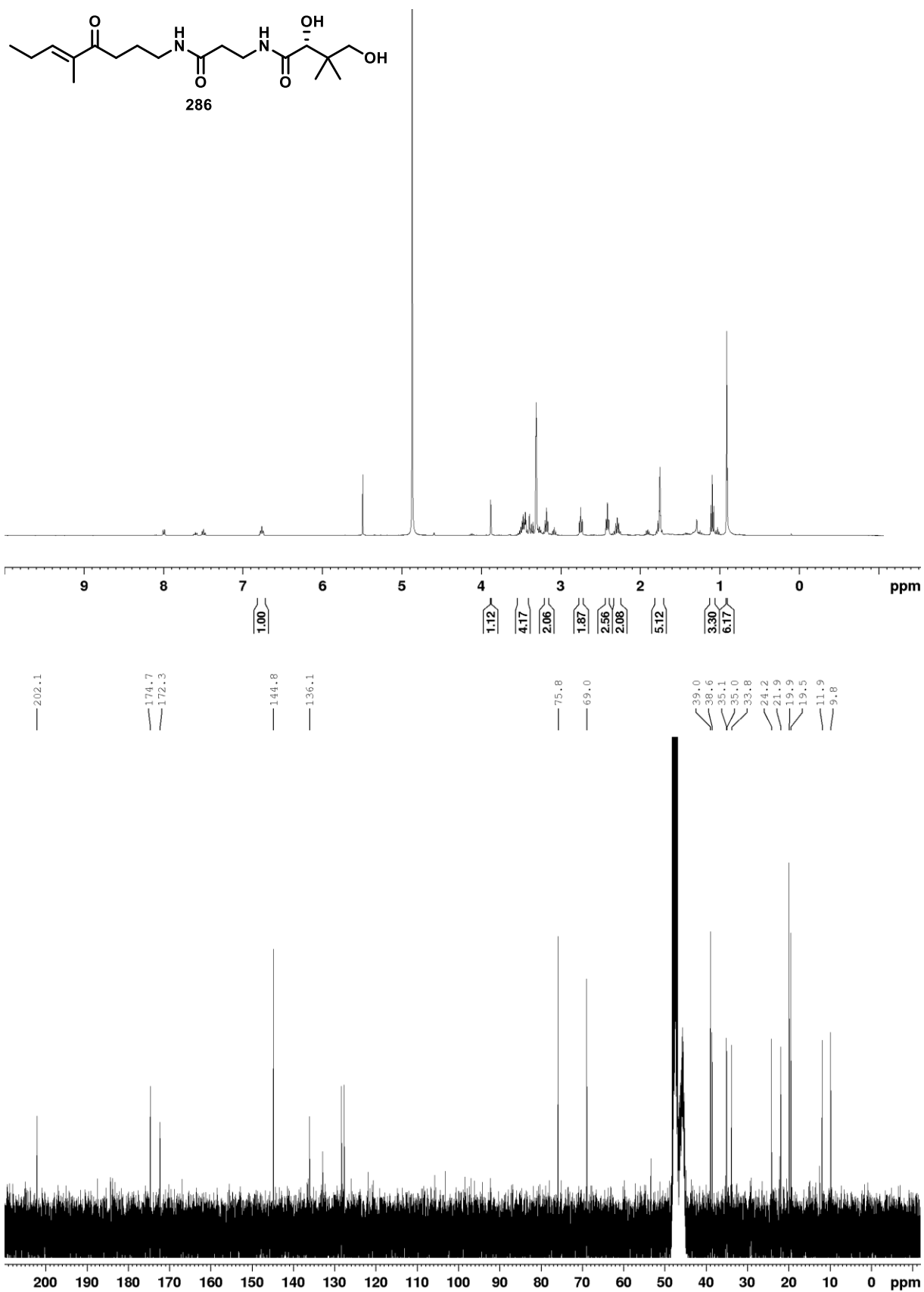

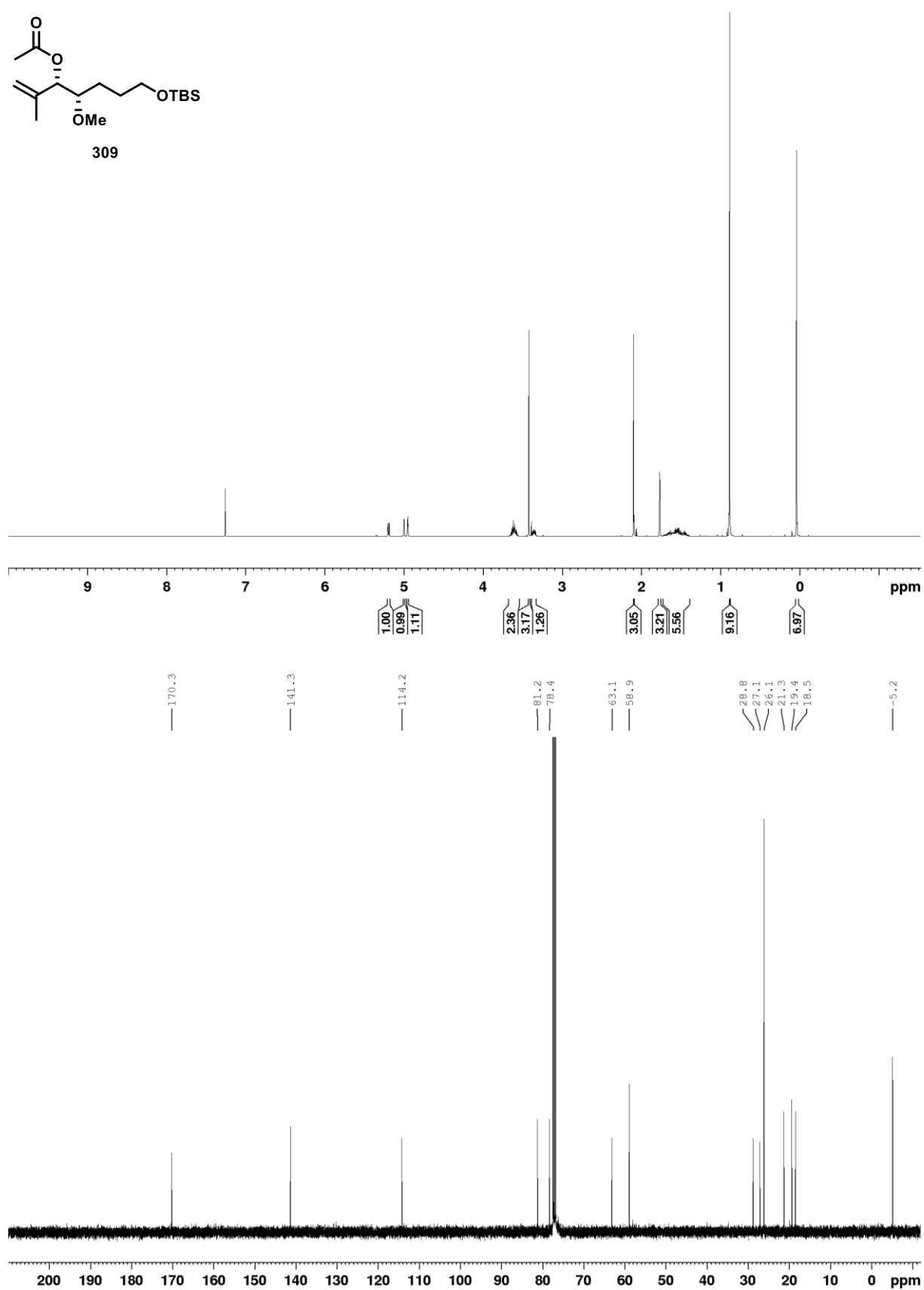
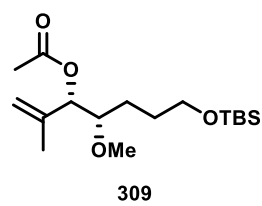

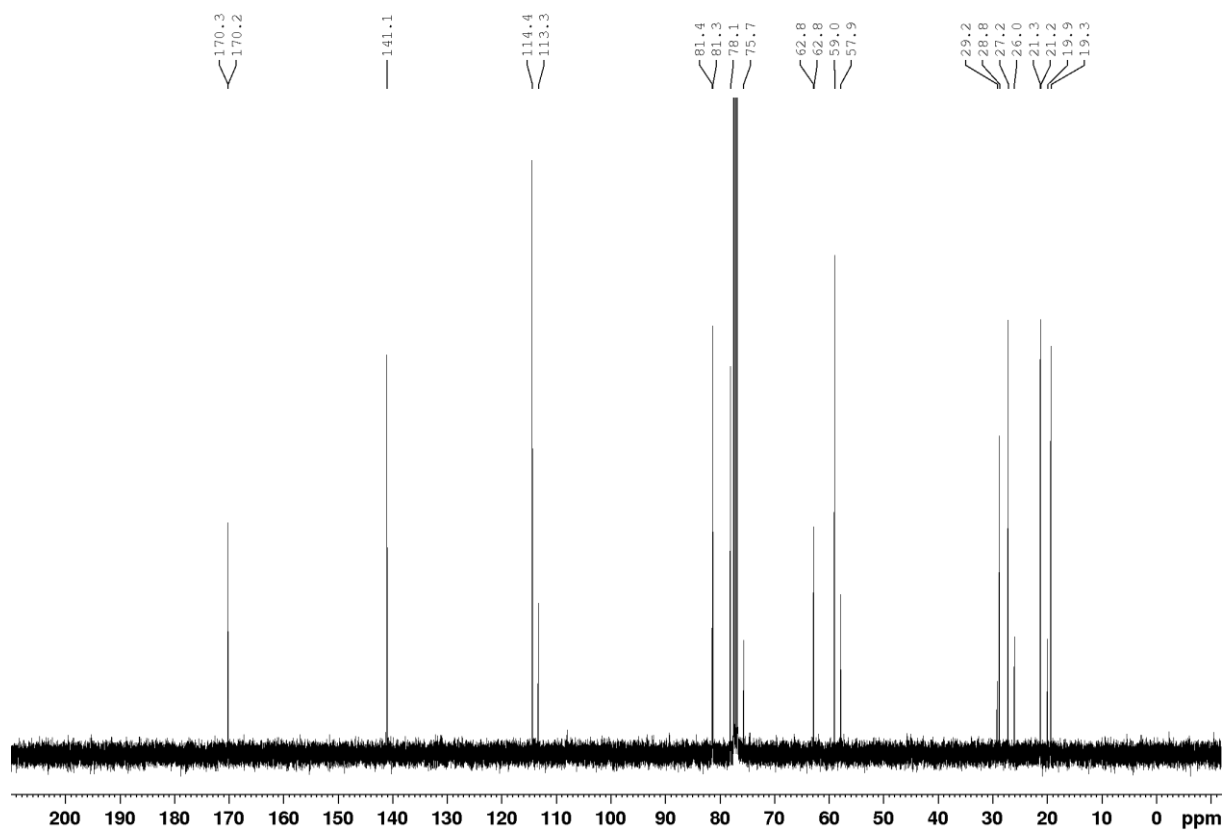
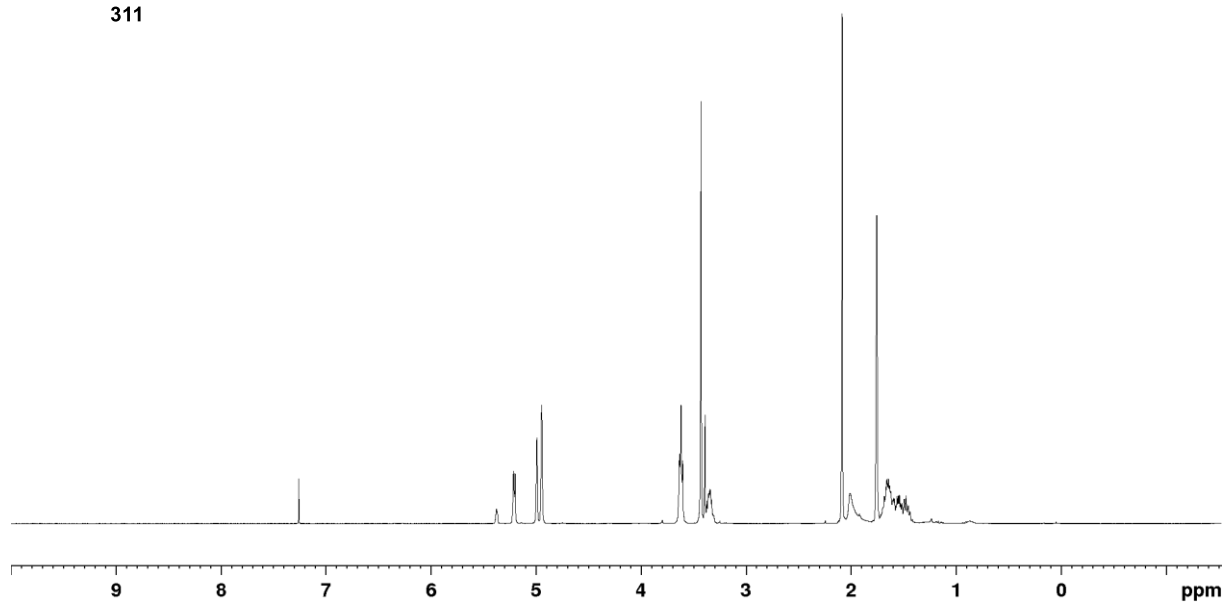
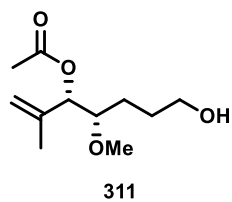

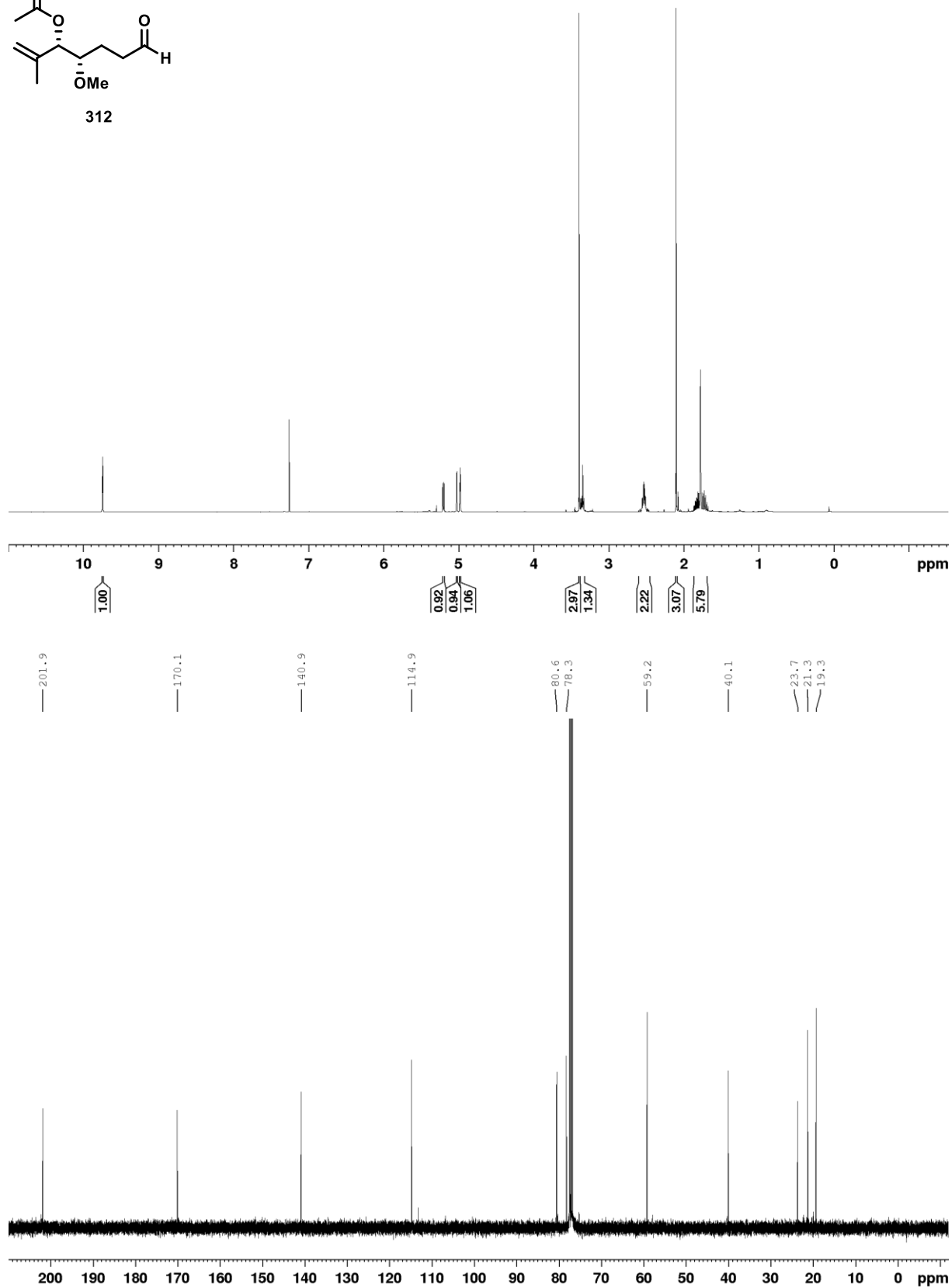
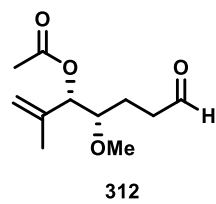

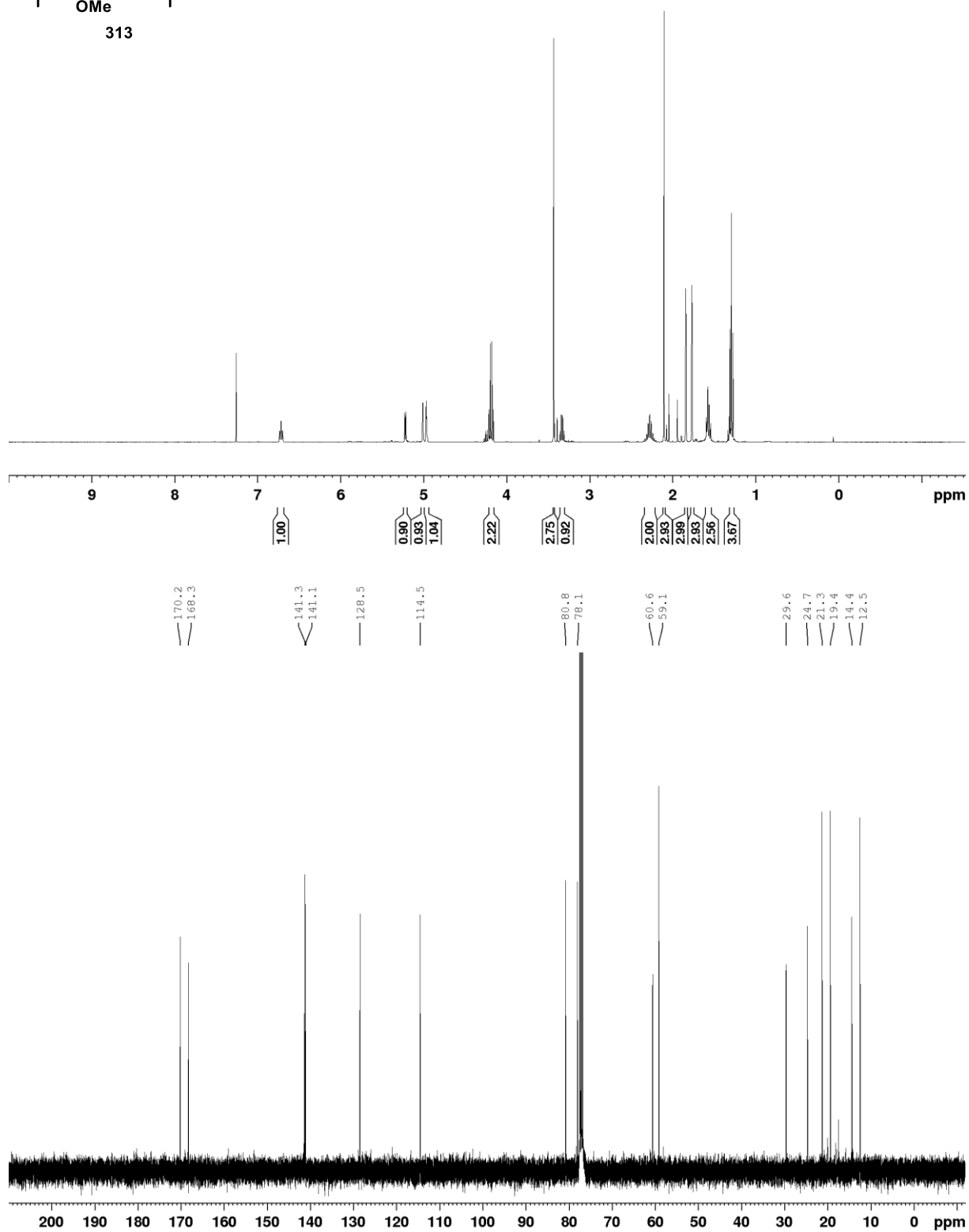
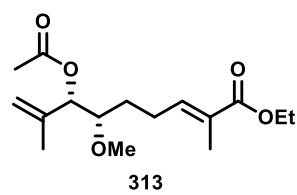



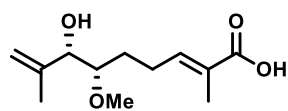

293

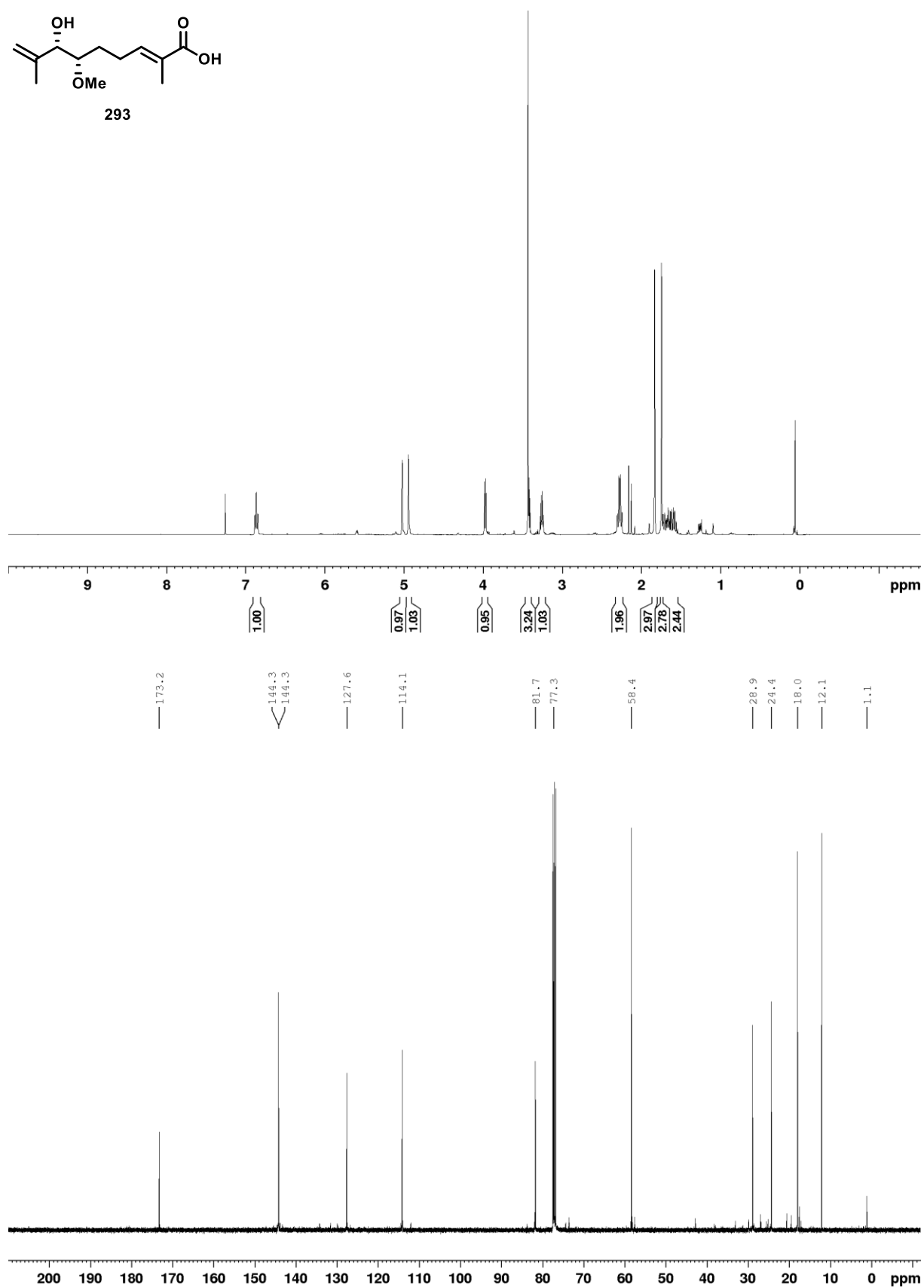

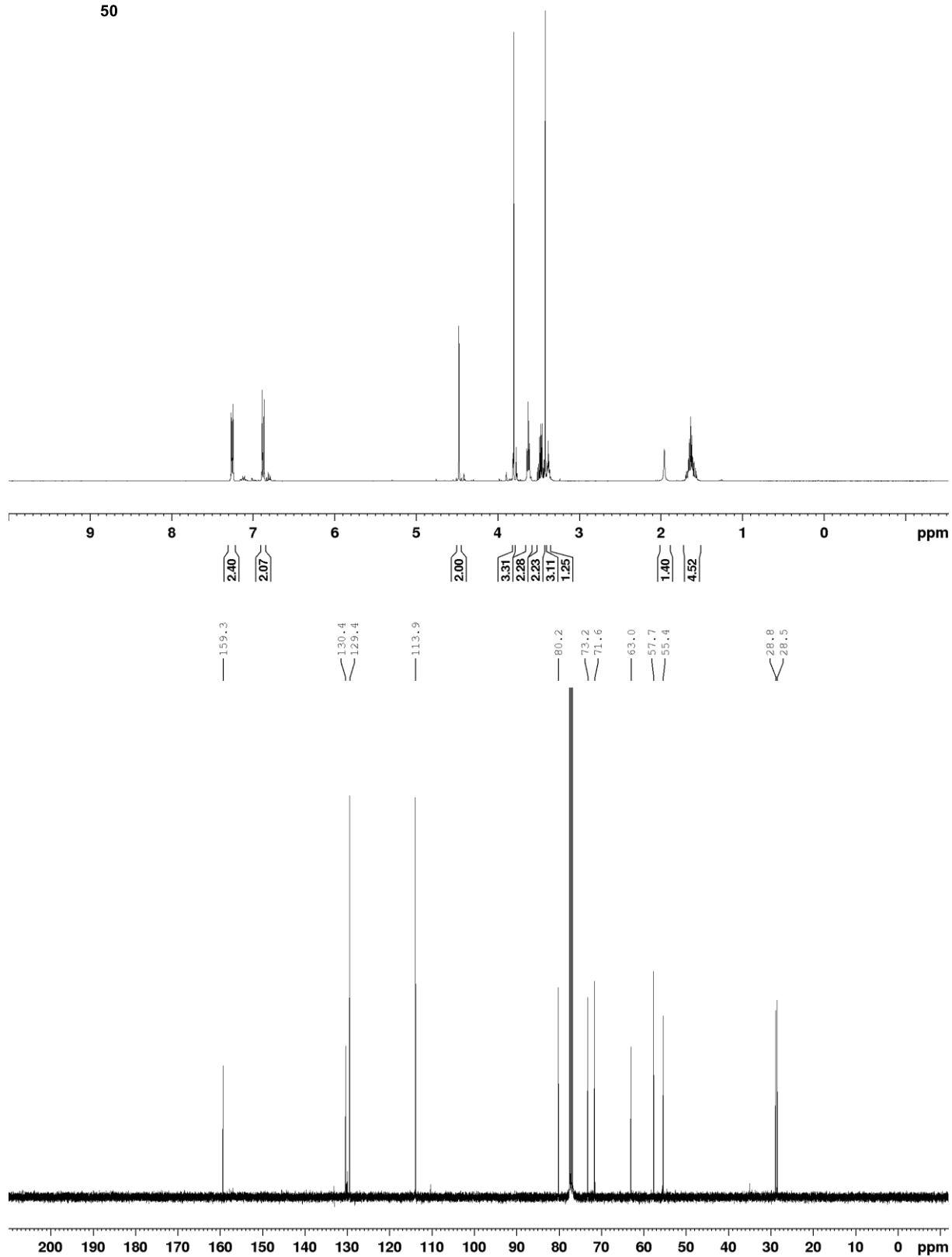
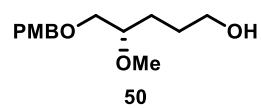

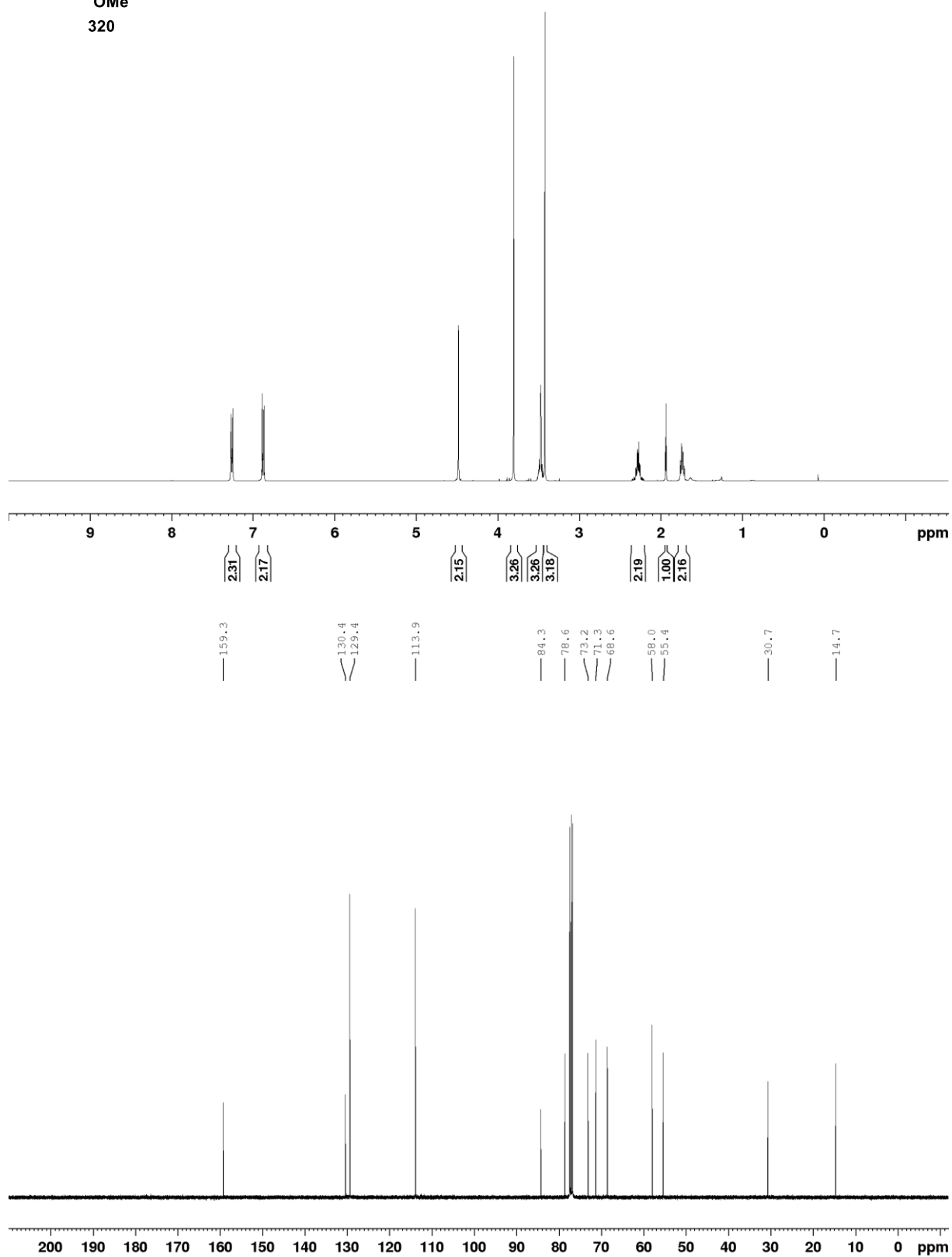
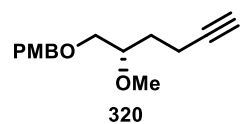

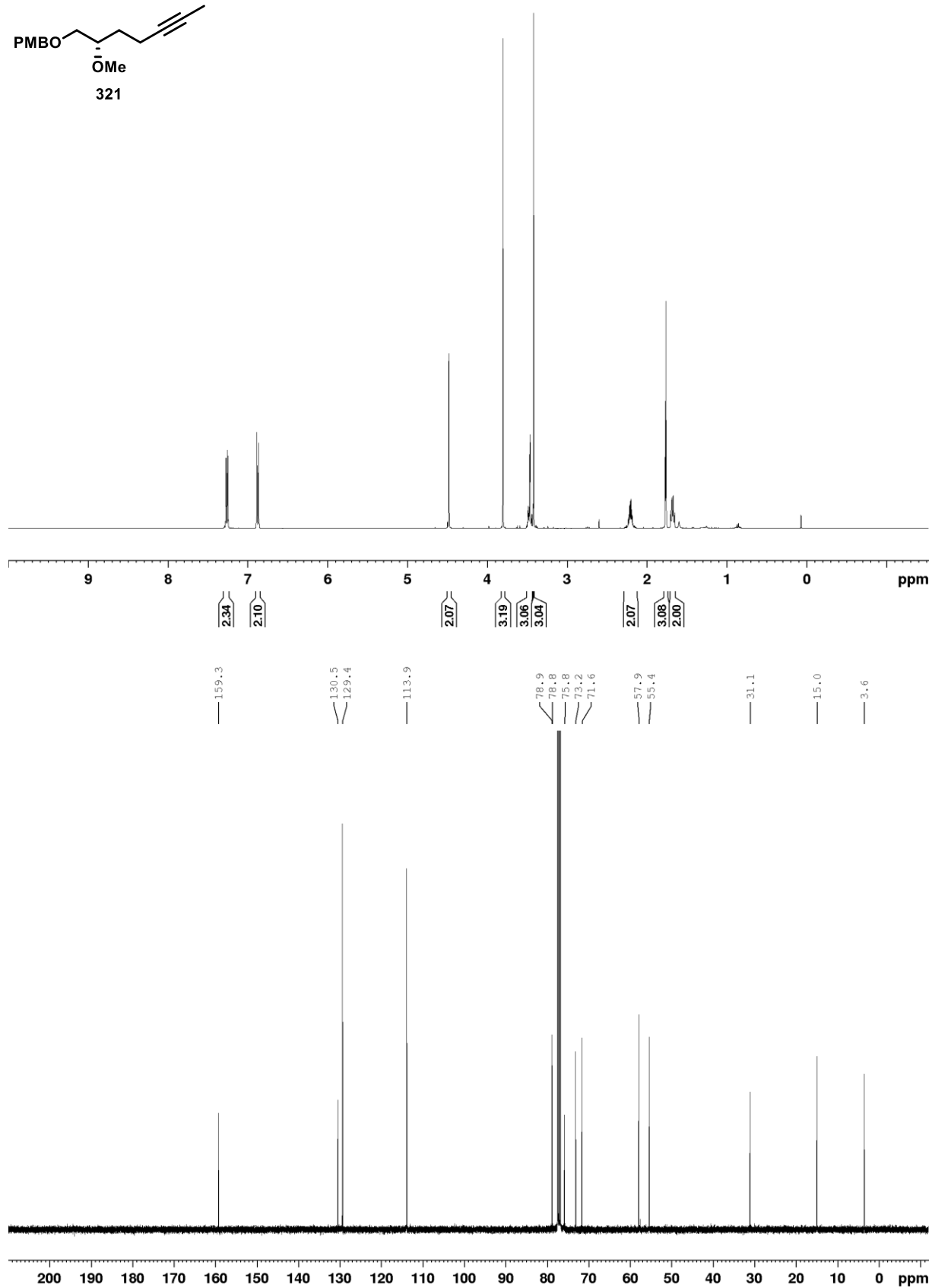
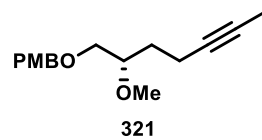

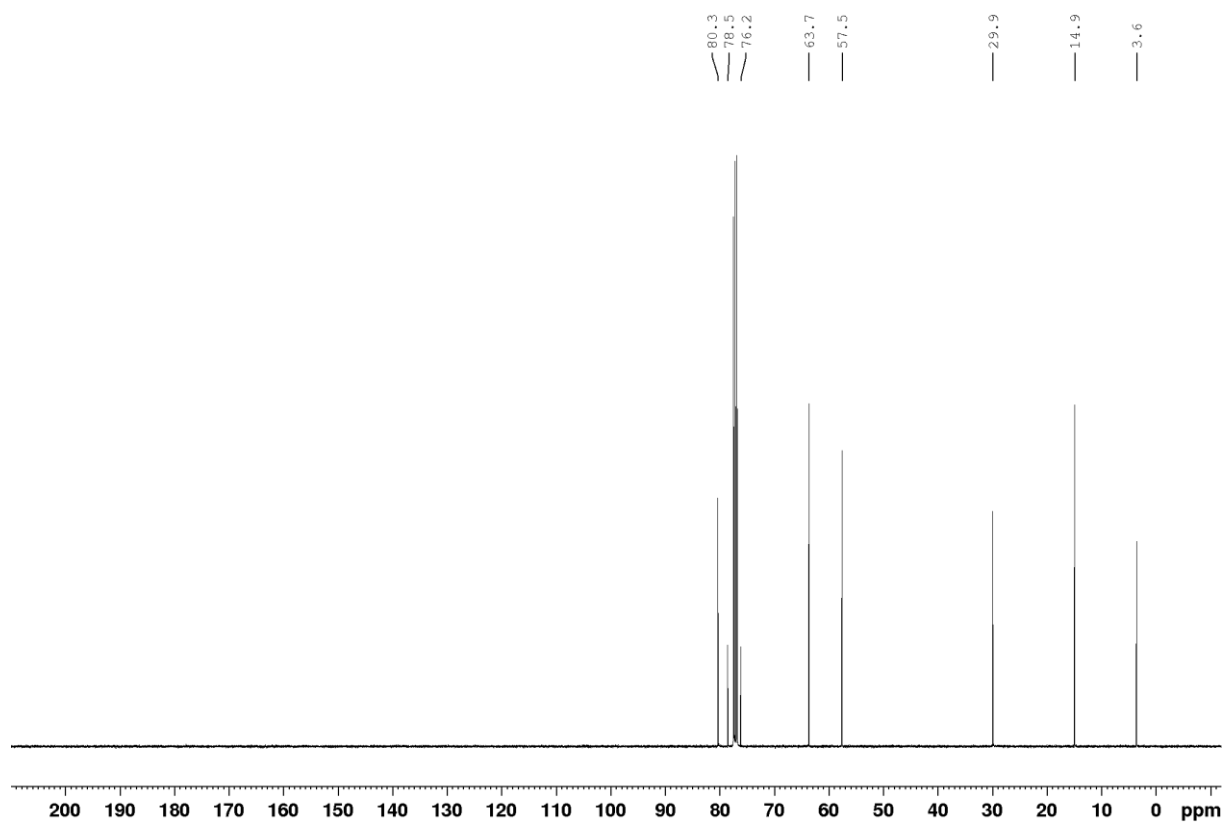
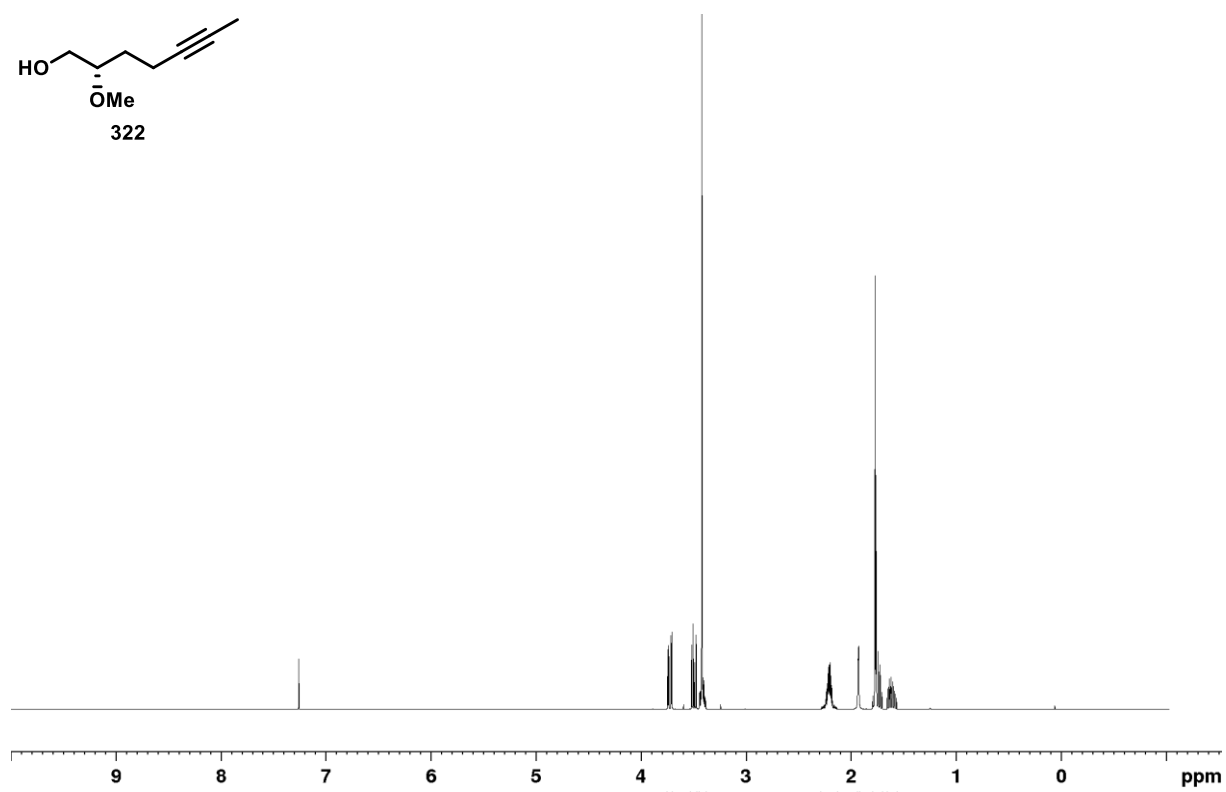
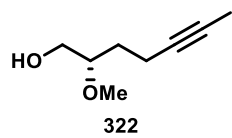

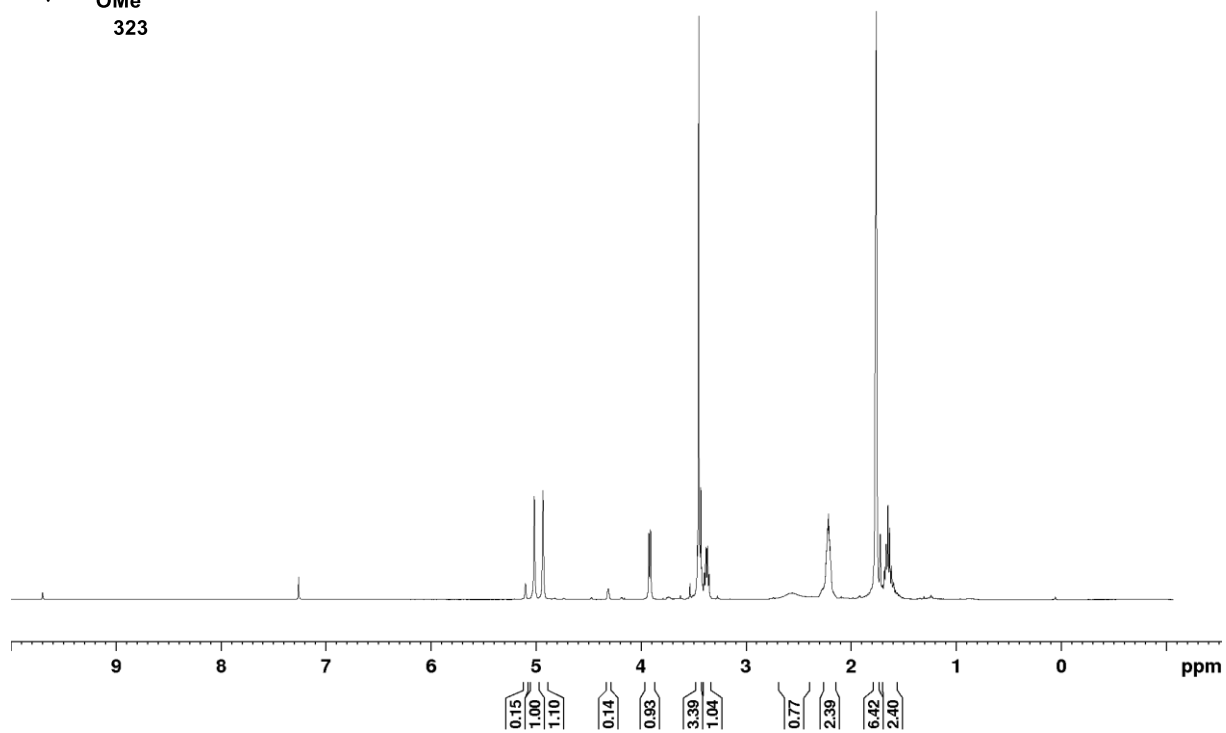
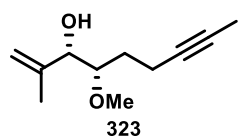

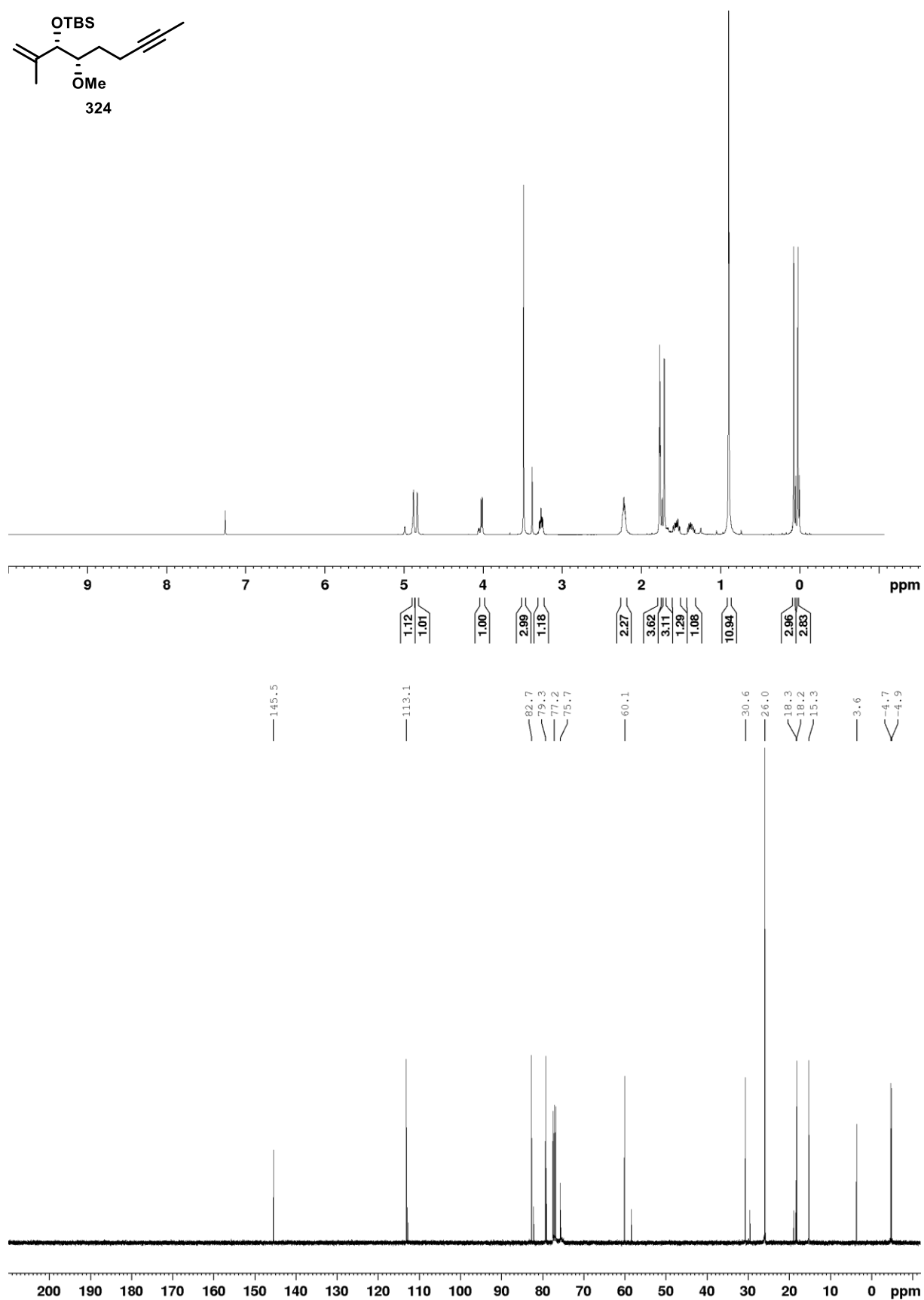
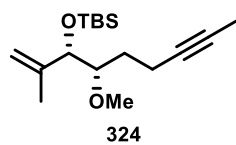

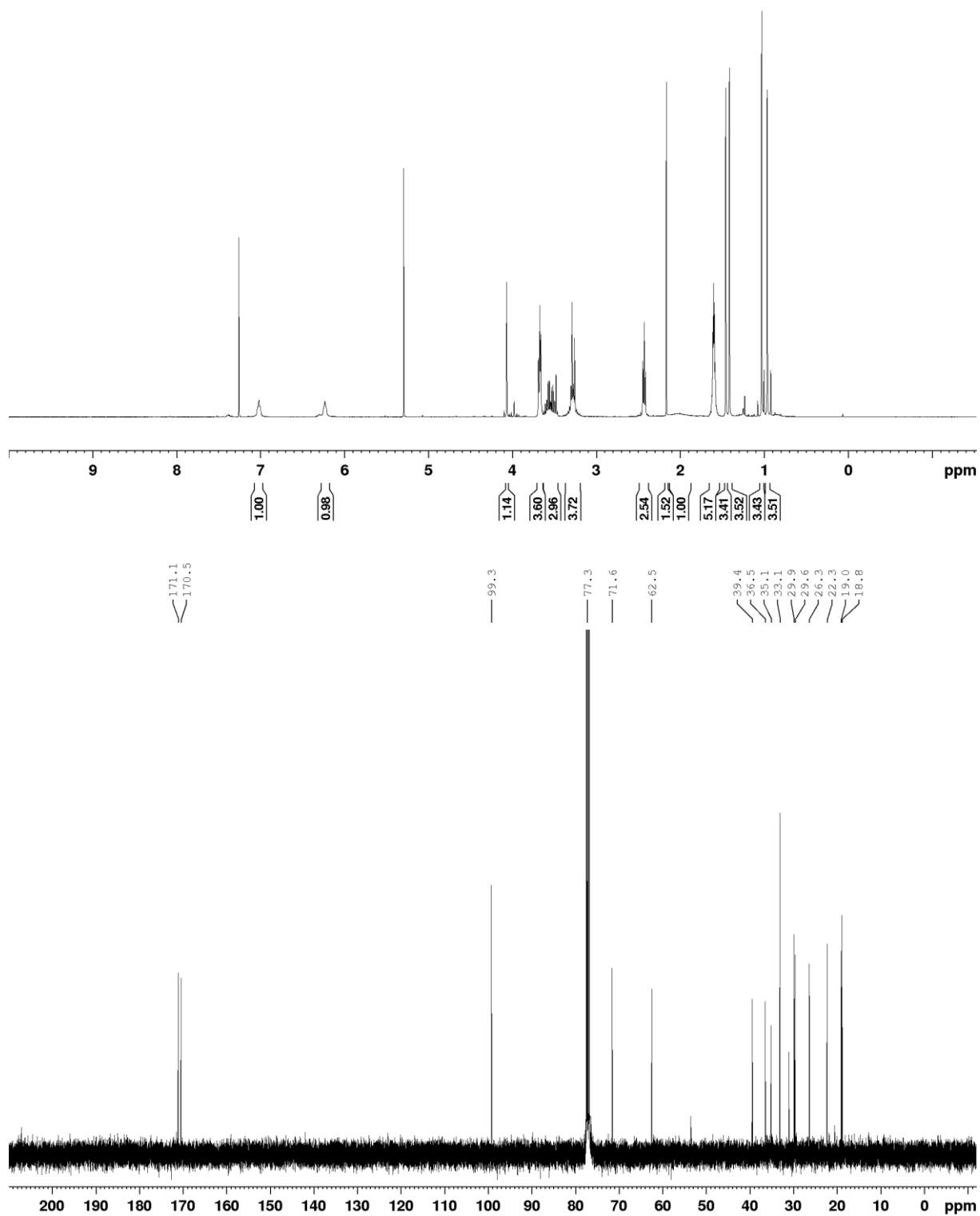
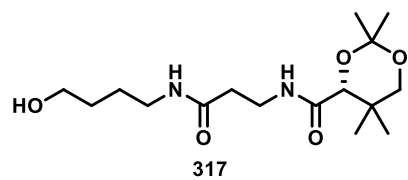



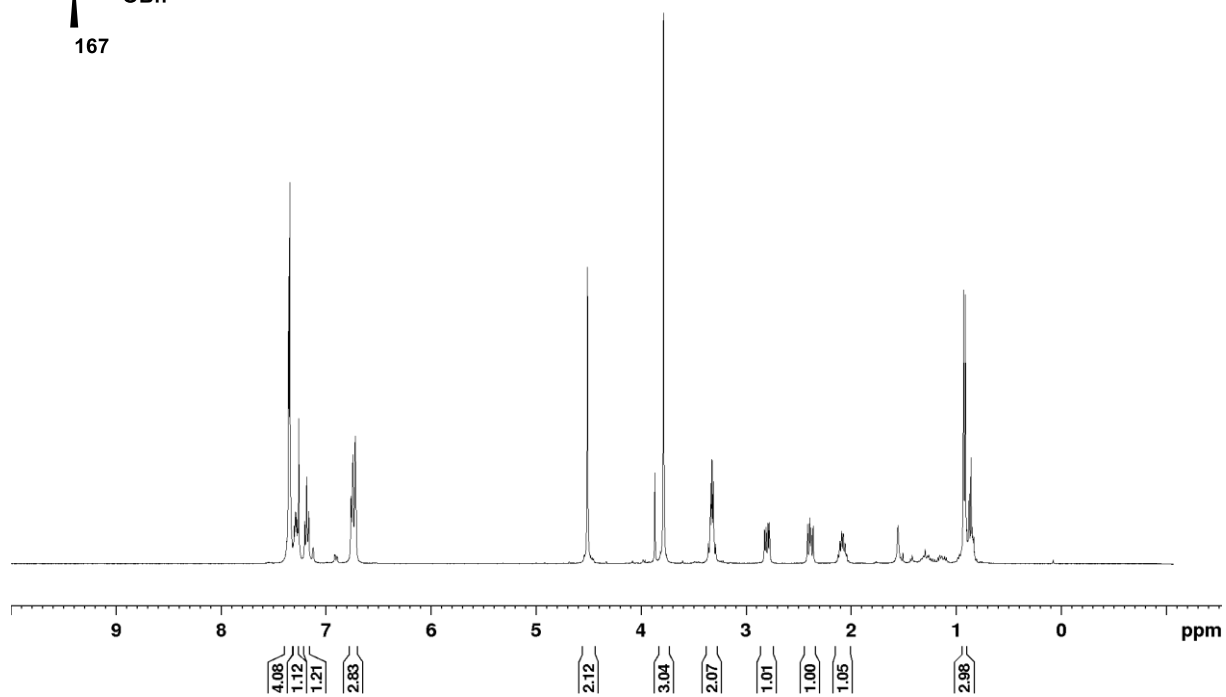
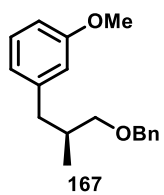
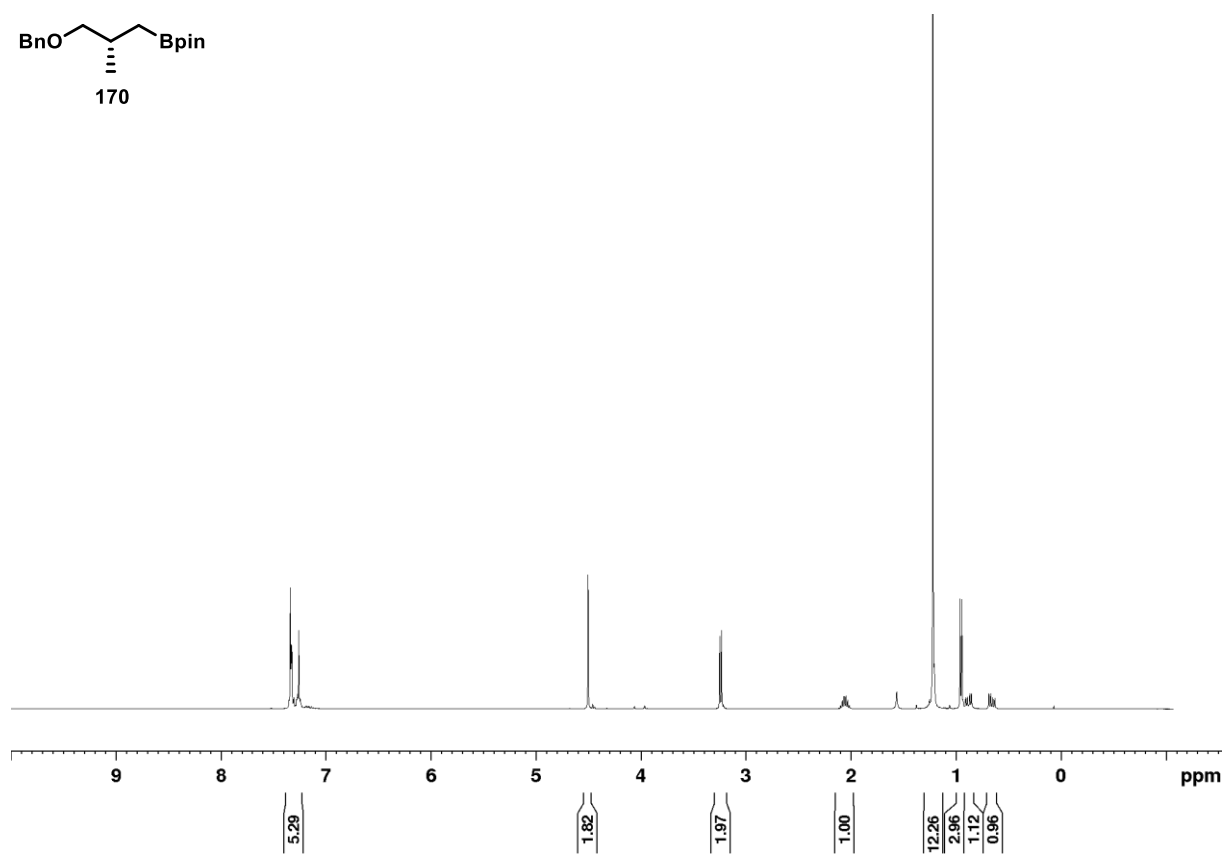
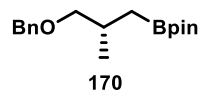

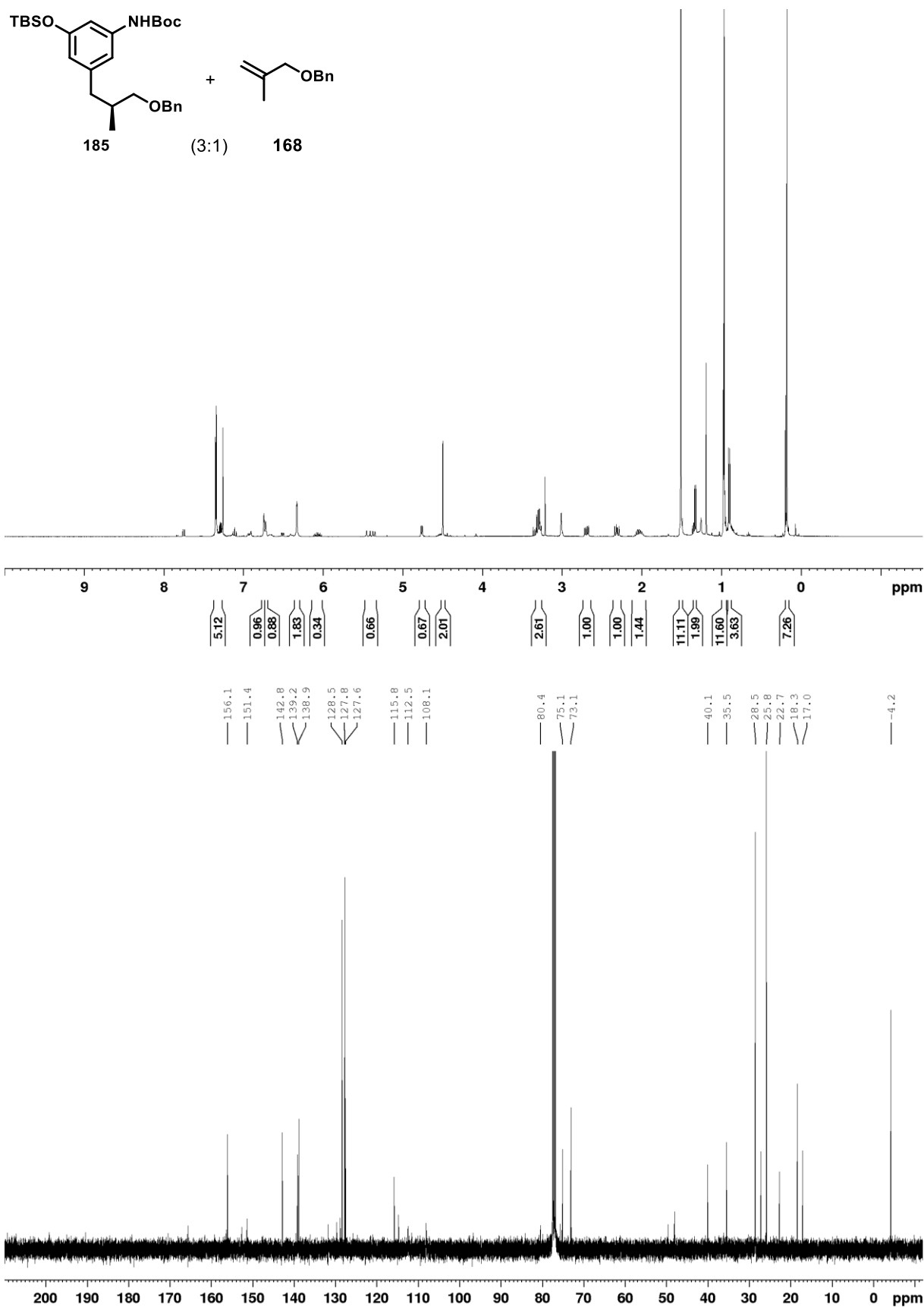

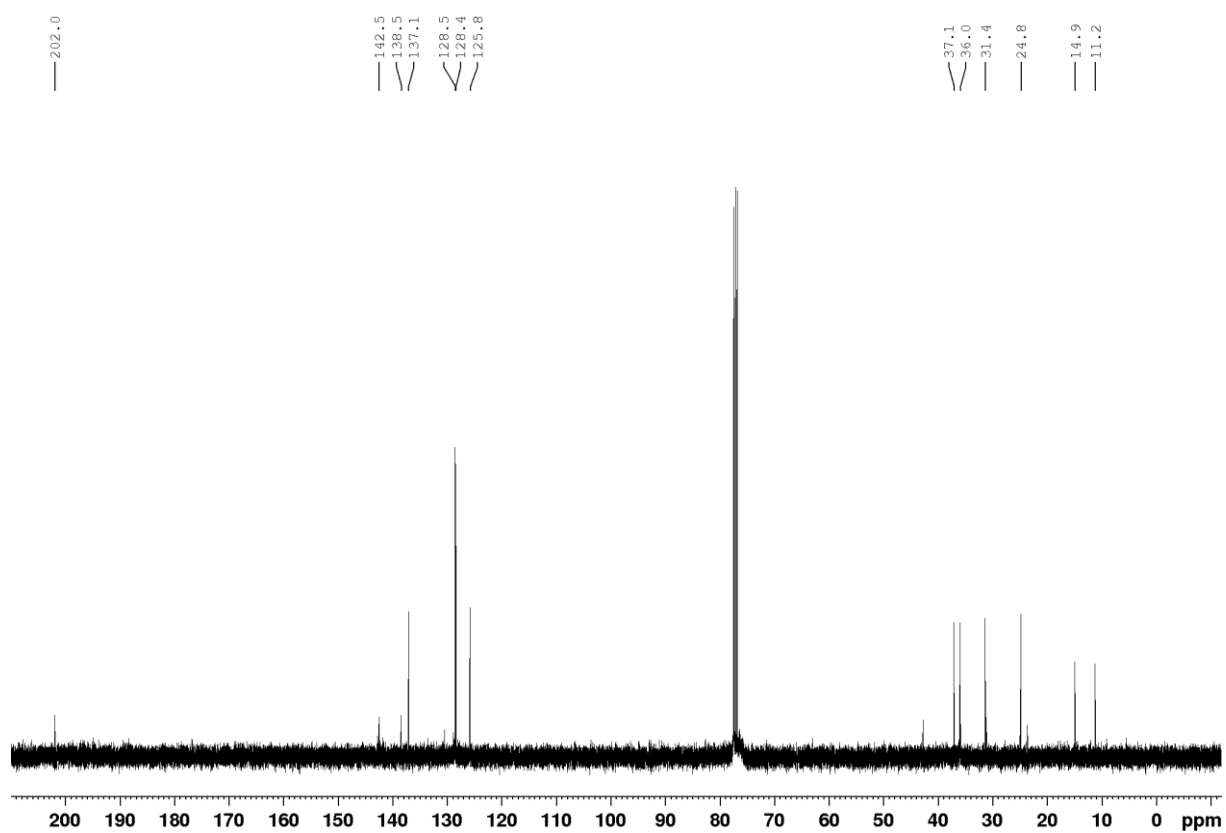
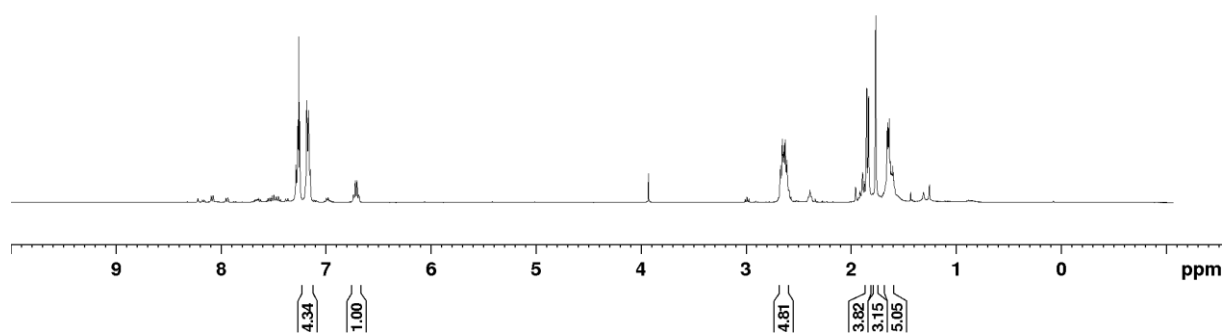
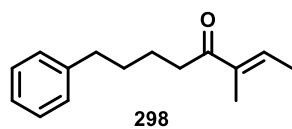

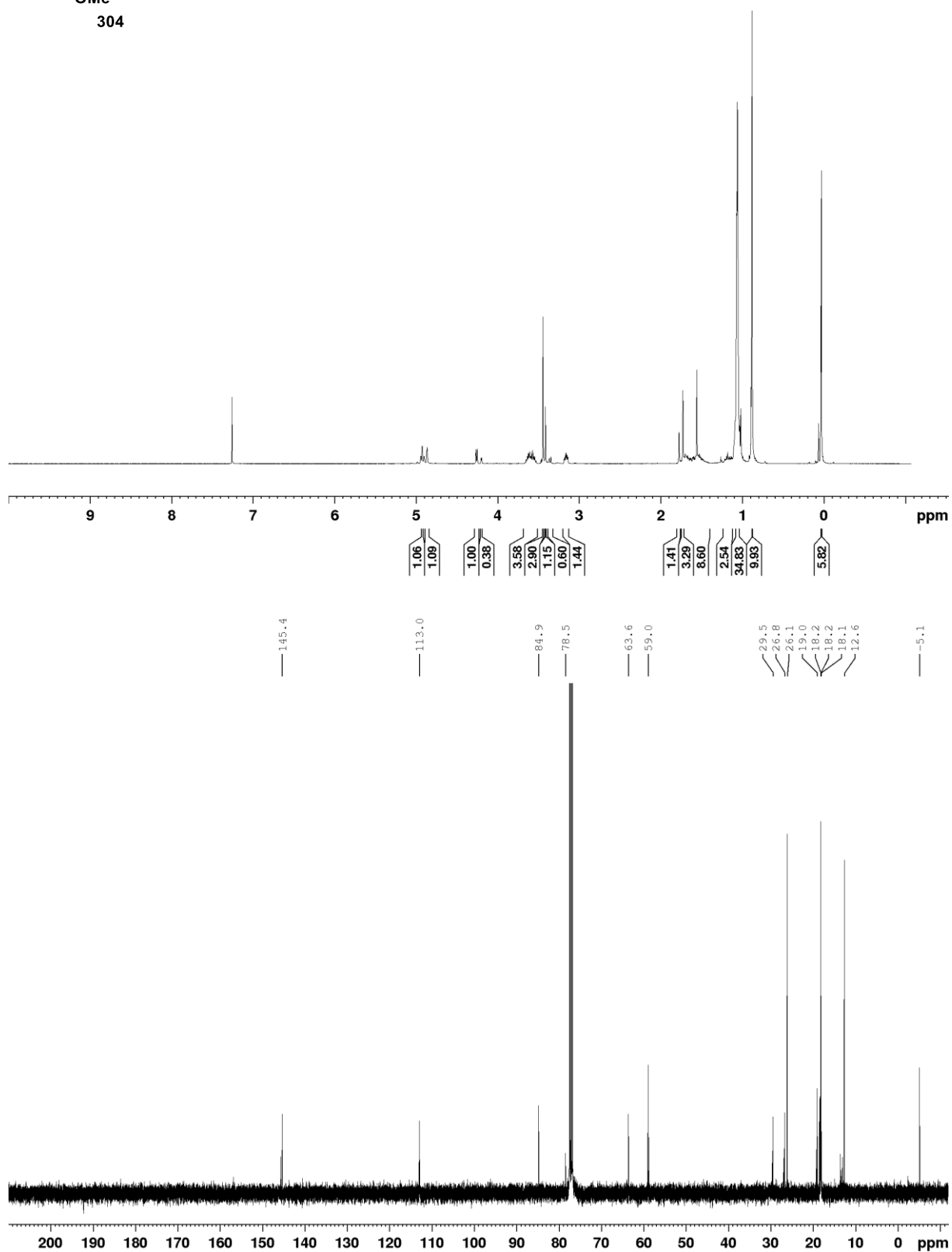
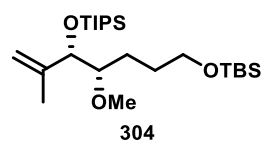

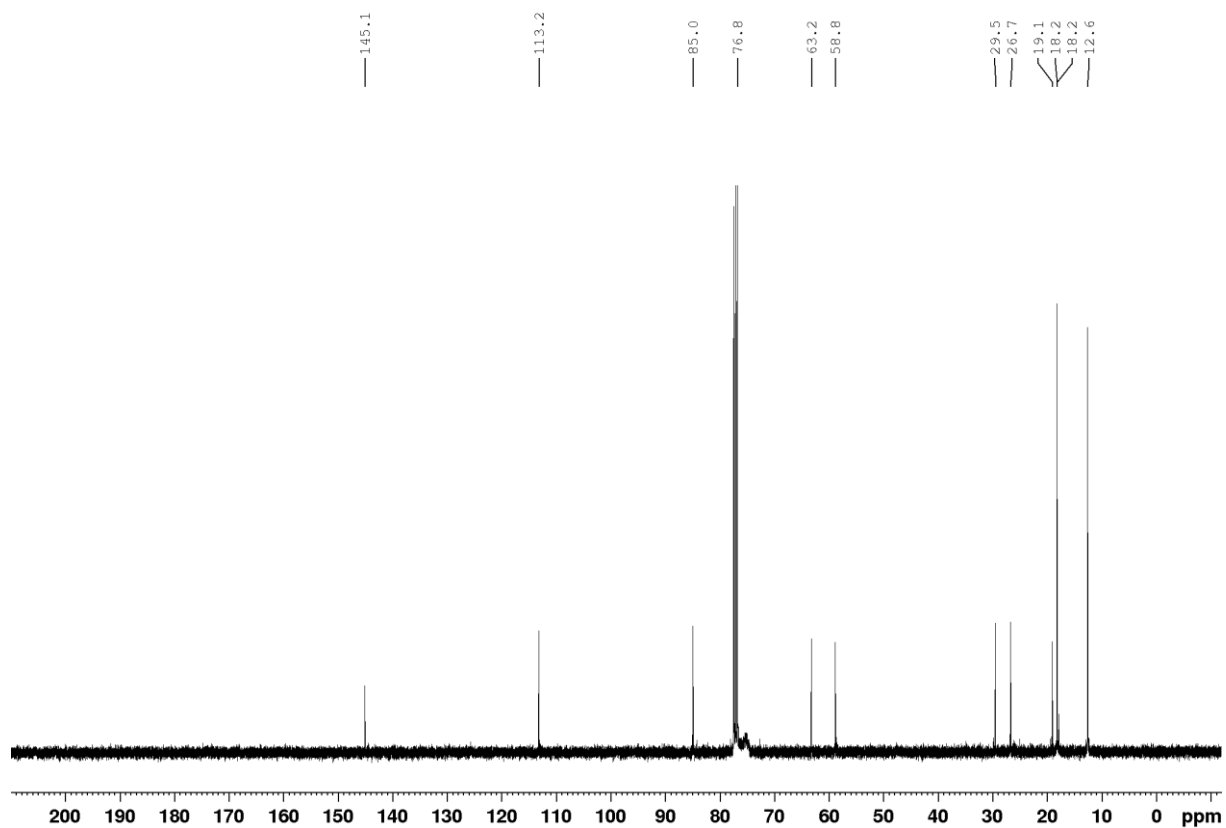
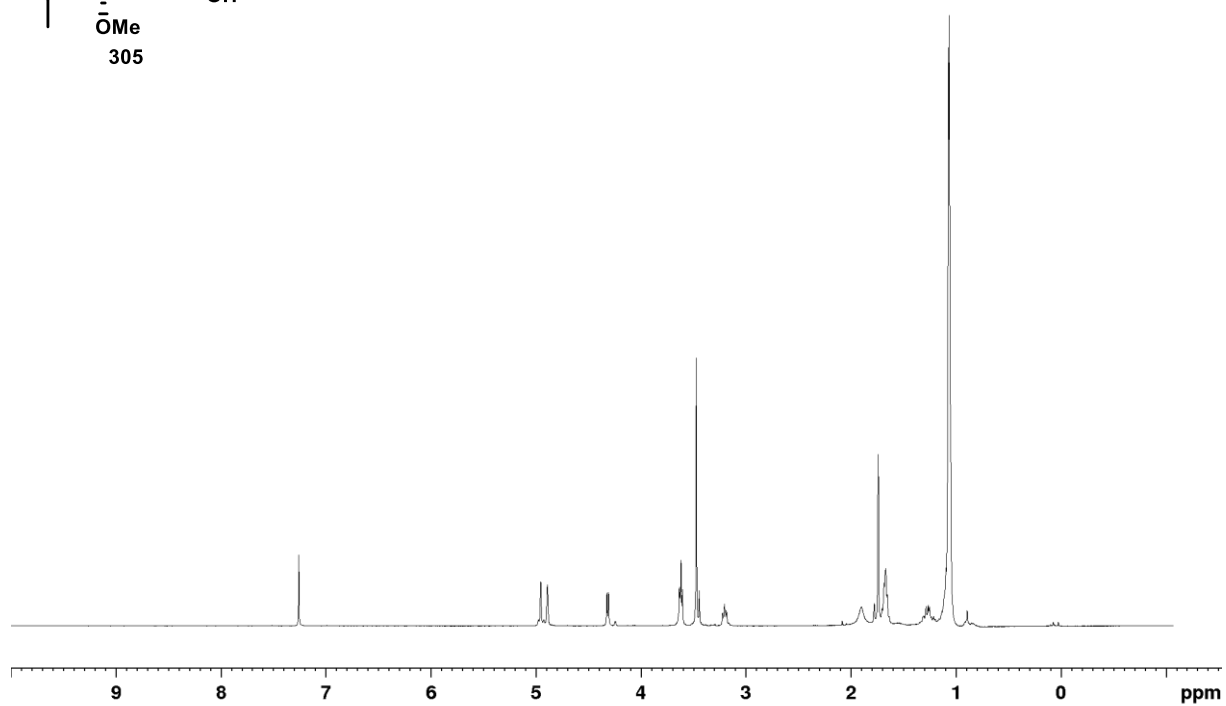
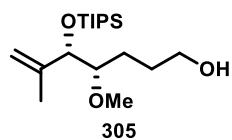

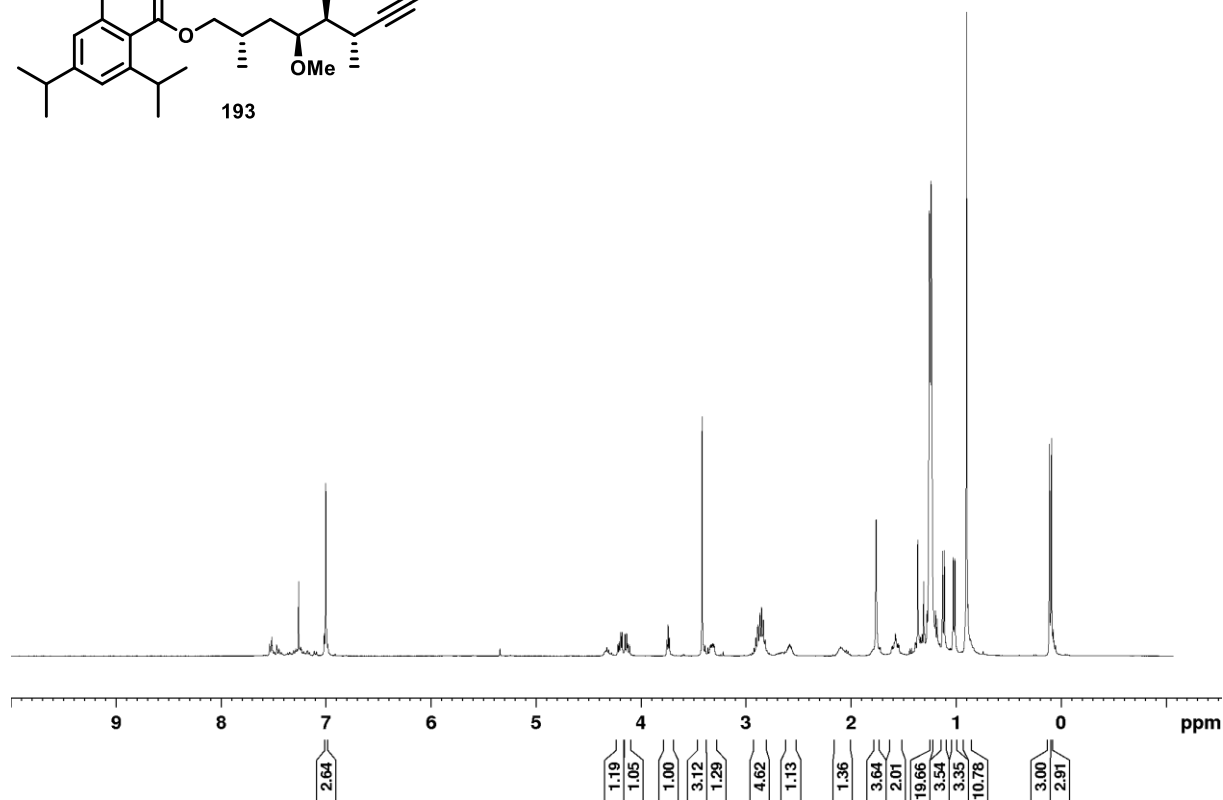
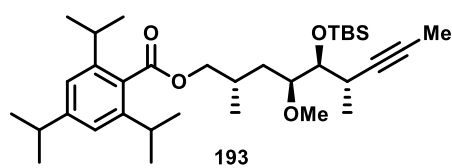
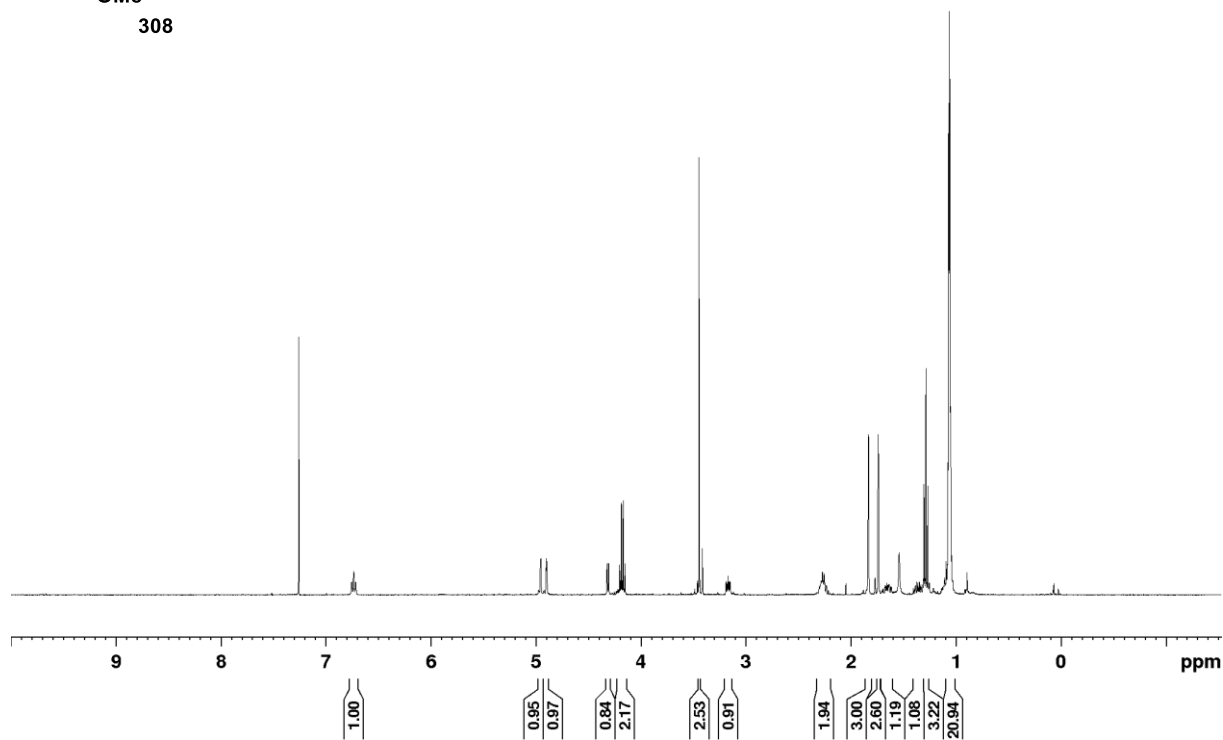
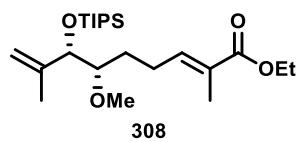

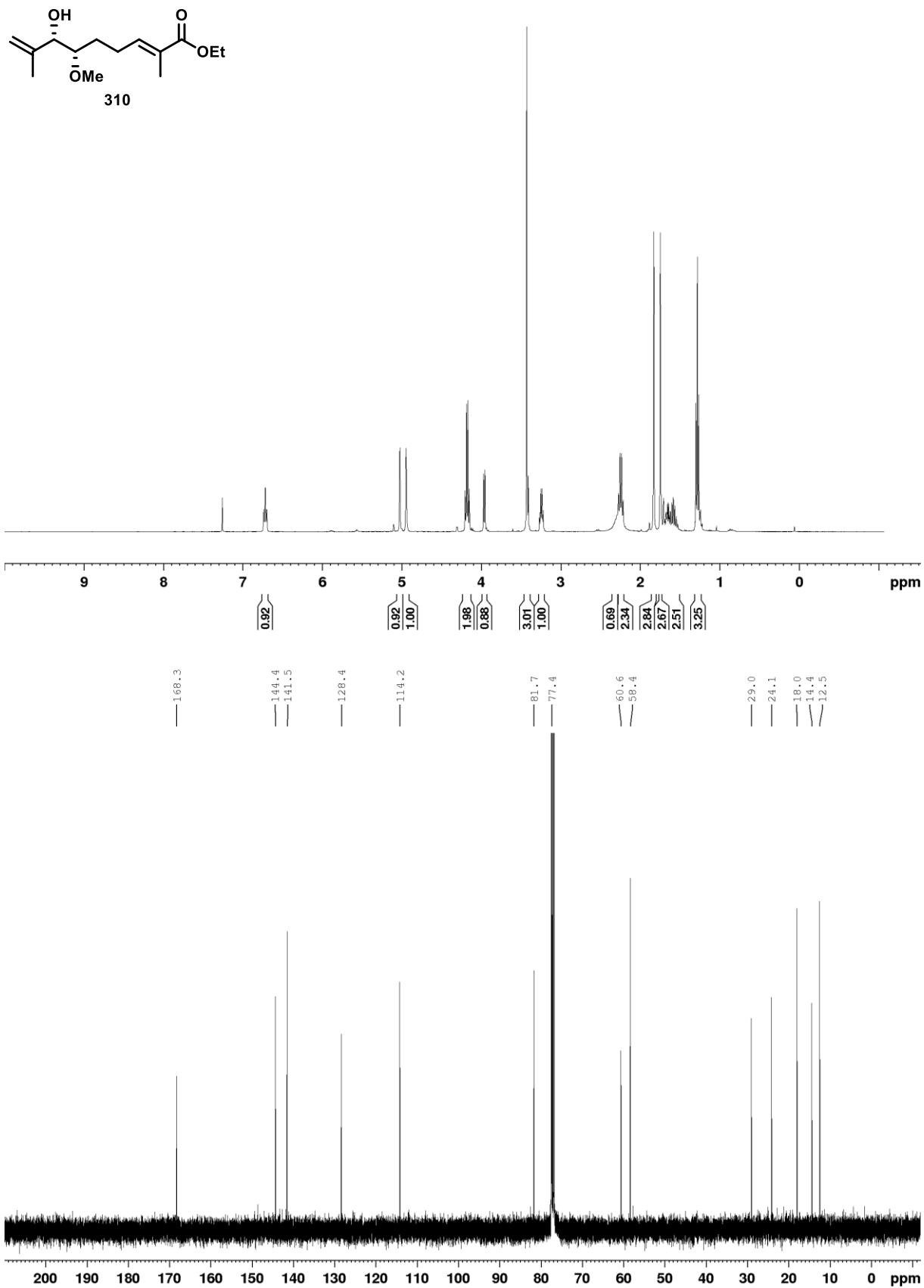

## Danksagung

Mein ganz besonderer Dank gilt meinem Doktorvater Herrn Prof. Dr. Andreas Kirschning. Nicht nur für die Aufnahme in die Gruppe und das spannende Promotionsthema, sondern insbesondere auch für die sehr offene und angenehme Arbeitsatmosphäre und die interessanten Gespräche und Diskussionen abseits der Chemie. Vielen Dank für die vielen gemeinsamen Grill- und Stammtischabende, die Sie immer gern unterstützt haben und wann immer möglich dran teilgenommen haben. Diese haben der Promotionszeit ein besonderes Flair verpasst.

Herrn Prof. Dr. Markus Kalesse danke ich ganz herzlich für die Übernahme des Korreferats und die spannenden und lehrreichen Vorlesungen im Bachelor und Master, die mein Interesse an der OC geweckt haben.

Ein weiterer großer Dank gilt allen MitarbeiterInnen der beiden Analytikabteilungen, allen voran Dr. Gerald Dräger für die technische und fachliche Unterstützung bei vielerlei Belangen. Bei Ines Roloff, Monika Griese und Linda Hermanns bedanke ich mich für die geduldige Unterstützung bei allen organisatorischen und bürokratischen Angelegenheiten.

Ein riesengroßer Dank geht an Janina und Tim. Mit euch wurde 131 zu dem was es war und die Zeit im Labor verging wie im Flug. Bei Helge, Friederike, Tim und Göran bedanke ich mich für das sorgfältige Korrekturlesen und die nützlichen Tipps und Hinweise. Duc und Conrad, allen vorgenannten Personen, sowie den weiteren Mitgliedern des AKKi danke ich für die schöne gemeinsame Zeit.



# Lebenslauf

## Persönliche Daten

|                       |                          |
|-----------------------|--------------------------|
| Name                  | Christian Bartens        |
| Geburtsdatum und -ort | 24.09.1991 in Hildesheim |
| Staatsangehörigkeit   | deutsch                  |
| Familienstand         | verheiratet              |

## Akademischer Werdegang

|                   |   |
|-------------------|---|
| 12/2017 – 12/2021 | <b>Promotionsstudium</b> an der Gottfried Wilhelm Leibniz Universität Hannover im Arbeitskreis von Prof. Dr. Andreas Kirschning, Thema: „Synthetic Studies Towards the SNAC Ester of <i>seco</i> -Progeldanamycin”  |
| 04/2015 – 09/2017 | <b>M. Sc. Wirk- und Naturstoffchemie</b> an der Gottfried Wilhelm Leibniz Universität Hannover, Masterarbeit im Arbeitskreis von Prof. Dr. Andreas Kirschning, Thema: „Synthetic Studies Towards New <i>seco</i> -Progeldanamycin Derivatives“  |
| 08/2016 – 02/2017 | <b>Forschungsaufenthalt</b> (Erasmus Stipendium) an der Umeå University, Umeå, Schweden im Arbeitskreis von Prof. Dr. Fredrik Almqvist  |
| 02/2016 – 03/2016 | <b>Forschungsaufenthalt</b> (Stipendium Deutsche Technion-Gesellschaft) am Technion – Israel Institute of Technology, Haifa, Israel im Arbeitskreis von Prof. Dr. Ilan Marek  |
| 10/2011 – 09/2014 | <b>B. Sc. Biochemie</b> an der Gottfried Wilhelm Leibniz Universität Hannover, Masterarbeit im Arbeitskreis von Prof. Dr. Andreas Kirschning, Thema: „Syntheses of Aromatic Azides and Their Applications in Fermentations With a Blocked Mutant of <i>Amycolatopsis Mediterranei</i> “ |
| 08/2004 – 06/2011 | <b>Abitur</b> am Gymnasium Michelsenschule Hildesheim   |

## Publikationen

P. Singh, D. E. Adolfsson, J. Ådén, A. G. Cairns, C. Bartens, K. Brännström, A. Olofsson, F. Almqvist, *J. Org. Chem.* **2019**, *84*, 3887-3903.

## Wissenschaftliche Beiträge

### Vorträge

- “Amide Synthases as Chemobiosynthetic Tools for Challenging Macrolactamizations”, 3<sup>rd</sup> European Conference on Natural Products, Frankfurt am Main, Sept. 2018
- “New *seco*-Progeldanamycin Derivatives: Tools to Study the Substrate Flexibility of the Amide Synthase GdmF”, German-Polish-Baltic Conference on Organic Chemistry, Hamburg, Mai 2018

### Posterbeitrag

- International Symposium on Synthesis and Catalysis, Evora, Portugal, Sept. 2019