

—
distribution to consumption

2

distribution to consumption

Food is City:

New Commons, New Rituals, New Technologies

Author: **Jörg Schröder**

Within Creative Food Cycles, the phase of distribution and consumption (Phase 2) is the one specifically linked to the city and to the daily practices of people. Food Cycles influence urban culture, economy, and society in the exchange and sharing not only of material values but also of ideas, beliefs, technologies—conviviality makes community. A broad range of urban activities is linked to food: to package, store, transport, deliver, offer, market, exchange, conserve, cook, bake, prepare, serve, eat, drink, talk, sing, also to scarcity and abundance, to use all and everything and to waste, to produce and pro-sume. Tangible and intangible cultural heritage as well as future building culture can be related to Food Cycles in many ways.

When aiming to explore new concepts and models of Creative Food Cycles, distribution and consumption are not only major fields of new cultural expressions inherently connected with innovations in this phase: they also offer most interesting accesses and starting points to reshape systemic and processual aspects of Creative Food Cycles as main aspect of everyday life. In this sense, the concept behind the selection of good practices for this phase highlights spatial manifestations in the city—moving, temporary, permanent. They innovate urban practices of conviviality and at the same time innovate urban space. Bound to and inspired by food safety, biodiversity, organic production, regional production, urban-rural linkages, health, food knowledge and education, the selected projects focus therefore on the material, spatial, and performative experience of Creative Food Cycles in the city.

Looking forward to the next steps of the Creative Food Cycles project such as the co-creative workshops and installations, the selection of good practices aims at exploring success factors for processes of this creative and cultural

approach: how they start from and push forward civic engagement and social awareness of sustainable foodsheds (supply and distribution chains) and how they foster knowledge and strategies towards urban metabolism as material and immaterial manifestation of resilience and circular economy. Furthermore, the selected projects aim also to enhance multi-actor approaches towards Food Cycles, with particular attention to two dimensions: first, regarding the new roles of architects, designers, and cultural actors in novel constellations between professionals, civil initiatives, entrepreneurial stakeholders, city governments, and active city society; second, regarding the role of creative spatial-material as well as digital-virtual expressions and experiments in Creative Food Cycles for the initial setup, processual involvement, and upscaling of projects of urban transformation: how they succeed to become new cultural practices but also how they influence urban change and urban space.

The collection of good practices shows how innovation in **Food Interactions**—interactions along the cycles and in general between food, city, and society—as new expressions of sharing and circular economy and of conviviality is gained with creativity. Hence, the aim to trace, explain, and push forward innovation is strongly bound to a design and research approach.

Cultural action not only as expression but as driver, influencer, and distiller of societal processes targets different steps, disciplines, and scales of design: initiating, enfolding, rooting innovation in and between product, communication, service, architectural, urban design, and in scales of objects, urban contexts, and new urban-rural networks. Innovation for the phase of distribution and consumption in Creative Food Cycles therefore is seen as the result of an interaction of three major fields: (1) In terms of resilience and

urban space, **urban commons** can become new places of sharing that enhance positive urban change; (2) In terms of participation and co-creation, new **urban rituals** can foster inclusion and creativity; (3) In terms of technologies, a major innovation for **technological and digital inventions** is seen in the linkage with **renewables**.

Sharing: New Commons

This category includes projects fostering new places of community-oriented and community-building Food Interactions. Starting from typological categories of market, kitchen, and table, the projects connect to a larger span of Food Interactions and foster different resilience and circular economy aspects. With the collective coordination of multiple aspects the projects can support sustainable urban transformation.

Firekitchen (Johanna Dehio) has been realised as artistic project involving people from the neighbourhood of Beixa in São Paulo. Firekitchen transforms processes into experiences that combines food preparation with the creation of the devices for cooking, and with the building of a kitchen unit, a dinner table, and a shelter, all made with renewable material clay. Inspired by the Brazilian Barro Preto pottery, clay forming, drying, and burning initiates conviviality and new commons, built on the social knowledge of its new inhabitants: a cultural activity that refers to the roots of the city and of human aggregation. The **Mpreis** supermarket in Innsbruck (Silvia Boday) fosters activities in the public space in the centre of town and is accessible to everyone—opposed to current trends to allocate supermarkets on roundabouts at city edges. The concept of Mpreis to provide a café and an inviting entrance area strengthen contribute to new commons, also as part of a regionally networked supermarket model and of regional supply chains. The added value of the supermar-

ket for the community is expressed in the quality of the floor, of the light and the views between inside and outside, strongly opposed to the “closed box” of standard supermarkets.

Les Cols (RCR), a star-restaurant outside of the metropolitan centre in Catalunya, creates new linkages between city and countryside and establishes temporary communities and a place of new commons to enhance culture and knowledge of biodiversity. Architecture supports the entrepreneurial and cultural initiative with the creative new interpretation of historic buildings, high quality working spaces for the cooks and transparencies between the building and the landscape. Experimental rediscovery of regional food products and food knowledge is linked with quality chains of regional production.

Accelerators: New Rituals

Projects in this category initiate and implement new urban rituals, originating from Food Interactions in temporary, moving, and permanent settings and constellations in the city. Creativity, social involvement and co-design contribute to new food practices in urban life. Performativity of urban space towards circular economy can be fostered by sensual and artistic experiences as driver of upscaling processes. The **Manifesto Market** (reSITE) induces new rituals in Prague by using an urban gap temporarily, seeding and initiating Food Interactions in a cross-fertilisation between artistic, cultural, and food concepts, with 20 restaurants and designer’s pop-up stores in 27 containers. The project joins economic sustainability with a strong design perspective that creates a new landmark, new narratives, and new urban activities. The design of the market itself includes experiments in architecture, branding, furniture, and cultural programming. The online platform of reSITE has been developed as part of the EU project Shared Cities.

The **Fish Market** in Bergen (Eder Biesel Arkitekter) creates space for a vision of urban life inspired by Food Cycles: it accelerates upgrading of the harbour area, contributes to the touristic concept for the UNESCO protected historic centre of Bergen. Still, it is mainly an urban space for the activities and the community of the inhabitants in the large open ground floor of the market hall, transparent to the city and the harbour. New rituals extend from distribution to tasting, from knowledge to experience of sustainable fishery and biodiversity, not at least through the position in the harbour and towards the sea.

The project **Nest We Grow** (UC Berkeley & Kengo Kuma) is a platform of learning and gathering activities throughout the seasons of the year, according to the life cycle of local foods. The installation-building on the Japanese island of Hokkaido provides a new experience of the time-line of people and food, linked to the surrounding environment and weather. It initiates new rituals of community life, knowledge-sharing, culture in food and renewable resources. The focus on sustainability is fostered by the architecture of the Nest building, using renewable materials and traditional construction techniques in a modern composition.

Made in Cloister (Rosa Alba Impronta & Davide de Blasio) is a cultural project that contributes to the urban regeneration of the historic city in Naples. New rituals are explored and constituted in the interaction between artists and food, that involve the neighbourhood with social tables. With the concept of "Nutrition not consumption", manifestations and a market as part of the cultural project seek new ways to foster artisanal quality production in order to enhance local circular economy and biodiversity.

Technology: Renewables and Digitisation

This category highlights projects that use and invent innovation in digital technologies not only in communication and data, but also for the production and life-cycles of food settings that become lived and experienced **Food In-**

teractions. It includes knowledge and abilities of crafts and low-tech approaches to boost the use renewable materials, local techniques, and inspiring cultural contexts.

Shape-changing Pasta (Morphing Matter Lab) is a research and prototyping project in digital design and fabrication that invents a process towards “flat-pack” pasta in manifold shapes and “personalisation” in the digital fabrication platform. The research in cooperation with the Italian company Barilla combines digital methods with professional and artisanal knowledge of forms of pasta, of the use of raw natural materials, and of contexts of cooking and dining. The project extends inventions in durable and small packaging, to the use of renewable resources, circular economy and new food culture: *the city is where you share meals.*

The cultural project **Last Fisherman Standing** (We Are Foodpioneers CIC) uses ICT technology for a digital platform that samples tales, passion, and knowledge of small scale fishing industries. The project combines digitisation as social aggregator with material experimental events: pop up market, cookery class, boat building workshop. Communication design, research of manufacturing practices and traditional knowledge, and storytelling are merged towards learning practices that enhance a creative use of cultural heritage for circular economy: *the city is where you build common knowledge.*

The **Yatai Food Cart** (Note Architects) is part of a bottom-up architectural movement in Japan to connect the new awareness for regional contexts and sustainability with everyday practices of life in the megacity Tokyo, in order to foster life quality and cultural richness of Japanese urban space. Modularisation and digital design make these moving pop up kitchens and bars fit for self-construction. The project fosters an increased use of wood as renewable material in form of square timbers and plywood, based on lessons learned from traditional wood techniques in mobile food stands: *the city on the move.*

Manifesto Market is a gastro and cultural market established by the non-profit organization reSITE, located on a former wasteland in the heart of Prague. The project commissioned by Martin Barry, reSITE founder, to a trio of young female architects –winners of a student competition where the initial design was conceived– has been completed within 18 months.

Manifesto is built by 27 containers, 3 bars and more than 20 restaurants, located between two billboards, overlooked by an elevated highway and next to an unused railyards of Prague's Masaryk Railway station.

Everyday, the market welcomes a very diverse cross-section of visitors and more than 25 nationalities work at Manifesto while about 150 jobs were created. Manifesto is not a typical marketplace or food hall and it focuses on personal experiences. In an intimately designed and comfortable place, the curators make cuisine from white tablecloth restaurants accessible at street food prices. The daily program of top local DJs, live music, performance, summer cinema and classes is attracting those seeking a cultural experience for free.

Pointing to the organizer's penchant for the future city and international flare, the project has been conceived as the first fully cashless market in Czech Republic and it has been awarded the Best Retailer prize for the year 2018.

Two dozen top local purveyors, restaurants, chefs and Czech microbreweries offer special menus that cannot be found elsewhere in the city. At least one-third of the containers are dedicated to emerging businesses, providing them with a low cost of entry opportunity and good visibility and exposure, as a testing ground of their gastro ideas. Next to them, Michelin-rated chefs act as mentors. Manifesto is a truly collaborative project, developed in collaboration with local cultural powerhouse, Aerofilms. Manifesto Market provides a highly curated experience focused on food and culture in parallel to a low cost of entry for independent retail and gastro entrepreneurs working next to experienced brands in a creative environment.



image of courtesy of Manifesto Market _ ph: Jakub Červenka

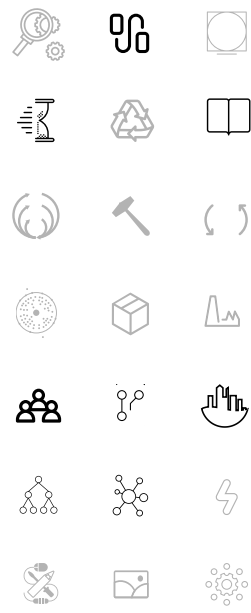
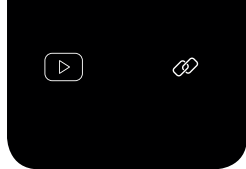

Manifesto Market

Author: reSITE _ Radka Ondrackova reSITE

Location / Year: Prague, Czech Republic / 2018

CAT1

CAT2
DISTRIBUTION
TO CONSUMPTION

CAT3

- PROCESS
- PRODUCT
- MATERIAL
- TABLE
- KITCHEN
- MARKET
- MODULE
- BUILDING
- INSTALLATION

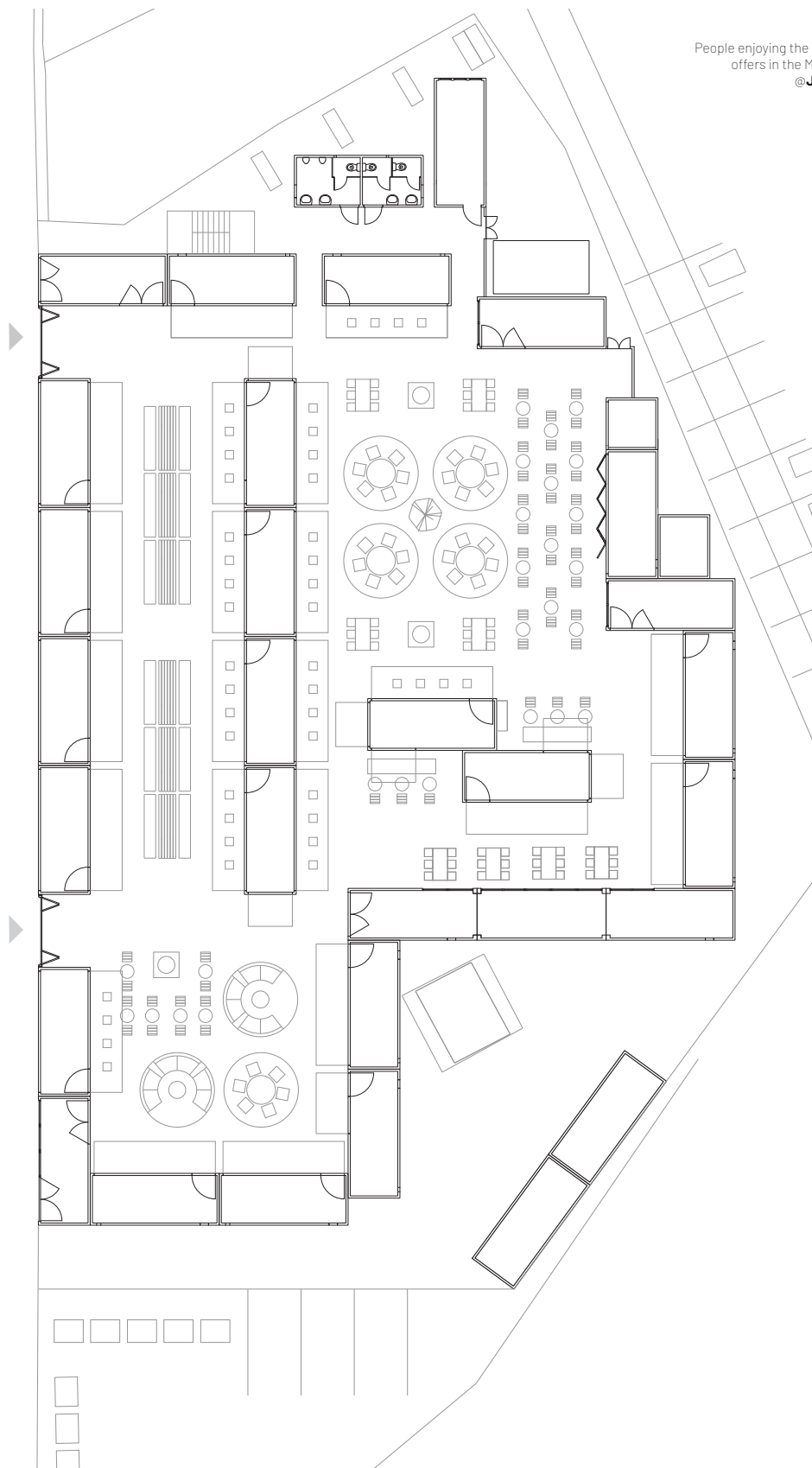

cover img

People enjoying the diversity of food offers in the Manifesto Market @Jakub Cervenka

fig 01 (up)

Layout plan of Manifesto Market © Elvira Islas

fig 021 03(right)

Cultural events in the evening at the Manifesto Market © Jakub Cervenka



Firekitchen is an exemplary process in which raw materials, food ingredients and clay are transformed into a usable kitchen unit, dinner table and shelter. It proposes an open public production and a common feast shared around a long table.

The project had its origin in the cultural center Vila Itororó in Brazil, where a carpenter from Bahia refused to cook the traditional Brazilian "Moqueca de Peixe" before coming back with a large, black clay pot and fish caught by his father.

This story demonstrates the basic assumption: a good dish cannot be prepared without the right pot!

Firekitchen focuses on the relationship between the object, the recipe for a specific dish, the people and cultural environment providing ingredients, by an applied research and an experimentation process.

The design workshop took place in the neighbourhood of Bixiga, Sao Paulo. The quarter is strongly influenced by co-existence of different cultural backgrounds.

A diversity of people with different knowledge, skills and interests participated. Four topics structured the collective creation of a functioning kitchen: drinking, cooking, stove and shelter.

All participants were involved to activate a commonly built kitchen, cooking, sharing experiences and recipes during a feast. With this method, Firekitchen explored the whole process from raw material to a usable product, which is low complex and can be understood without extensive knowledge or access. The sensual, archaic moment of putting the hands into the mud and cooking on fire frees the access to implicit knowledge.

The fireplace constitutes the centre of communication and cultural production, processing food or materials.

Clay pots can be found in all cultures, distinguished in construction and function due to local appearances, resulting in differentiated shapes for the preparation of ecologically reasonable and well-balanced recipes.

Observing and learning from vernacular intelligence, Firekitchen benefits from the multitude of elaborate objects, by fostering the connection to meaning and origin of dishes and utilities.



Image of courtesy of Joanna Dehio – ph: David Moritz

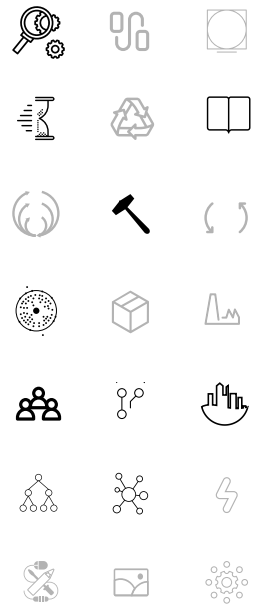

Firekitchen

Author: Johanna Dehio

Location / Year: São Paulo, Brazil / 2017

PROCESS

PRODUCT

MATERIAL

TABLE

KITCHEN

MARKET

MODULE

BUILDING

INSTALLATION



- Typology:
 1 Copaleo / Mexico
 2 Ibrik / Arb. World
 3 Asanka / Ghana
 4 La Chambe / Columbia
 5 Donabe / Japan
 6 Mushi Nabe / Japan
 7 Güvec / Turkey
 8 Kartoffelpf / Germany
 9 Römerkopf / Germany
 10 Mezcalero / Oaxaca
 11 Iichancha / Guerore
 12 Tajine / Marocco
 13 Barropreto / Brazil
 14 Upesi / Kenya
 15 Comal / Mexico

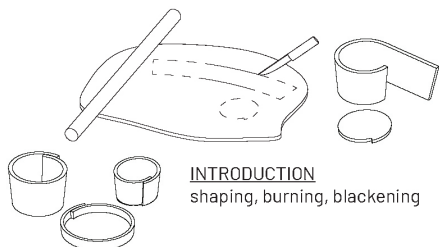

INTRODUCTION
shaping, burning, blackening

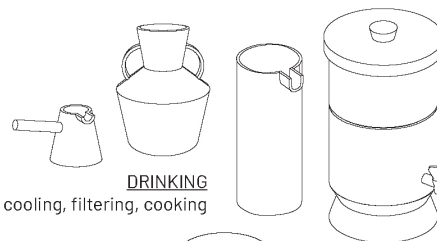

DRINKING
cooling, filtering, cooking



COOKING
steaming, boiling, baking, frying



FIRE
stove, oven, grill, rocket stove, smoker



fig 01 (up)
Drawings of cooking utilities © Johanna Dehio

fig 02 | 03(right)
Participants of Firekitchen workshop and different cookware in use ©Johanna Dehio

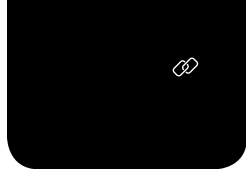

Nest We Grow is an open, public structure in the community able to reveal the creation of food and enhance its consumption while bringing the two closer together. The project's main intent is to bring people in the community together to store, prepare and enjoy local foods in the setting of Hokkaido, Japan.

Nest We Grow is spatially made up of food, and programmatically designed for food, according to a life cycle thinking: growing, harvesting, storing, cooking, dining, and composting. All members of the community help to complete each stage, allowing the structure to become a platform for group learning and gathering activities in the Nest throughout the year.

The structure is designed of platforms and walkways allowing visitors to wander and become immersed in the vertical and horizontal multitudes of local agriculture.

The ground level holds a community kitchen where people can gather, prepare food, and dine.

The wood frame structure mimics the vertical spatial experience of a Japanese larch forest from which food is hung to grow and dry. A tea platform in the middle of the nest creates a gathering space where people can visually and physically enjoy food around a sunken fireplace.

The Nest takes advantage of the transparent plastic corrugated sheets on the façade and roof, allowing light in for the plants, and heating the space during colder months, extending the usability of the Nest. Sliding panels in the façade and roof open to facilitate air movement through the structure during the summer and warmer parts of the day.

The openness of the façade allows the building to incorporate the surrounding natural environment into the interior climate, but can also be closed off to create a buffer between the two.

The funnel-shaped roof harvests rainwater and snowmelt. The collected water is delivered to tanks that are then used to irrigate the plants in the concrete wall.

The shape signifies the Nest's ability to bring nature in the form of air, water and light into the Nest.

image of courtesy of Ling Eunreock, Hsin-Yu Chen, ph: Shinkenchiku Sha



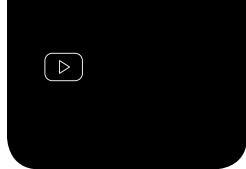

Nest We Grow

Authors: UC BERKELEY (Prof. D. Buntrock, H. Chen), KENGO KUMA AA (T. Saikawa)

Location / Year: Hokkaido, Japan / 2014

cover img

Outside view with the design team of Nest We Grow
© Shinkenichiku Sha

PROCESS

PRODUCT

MATERIAL

TABLE

KITCHEN

MARKET

MODULE

BUILDING

INSTALLATION

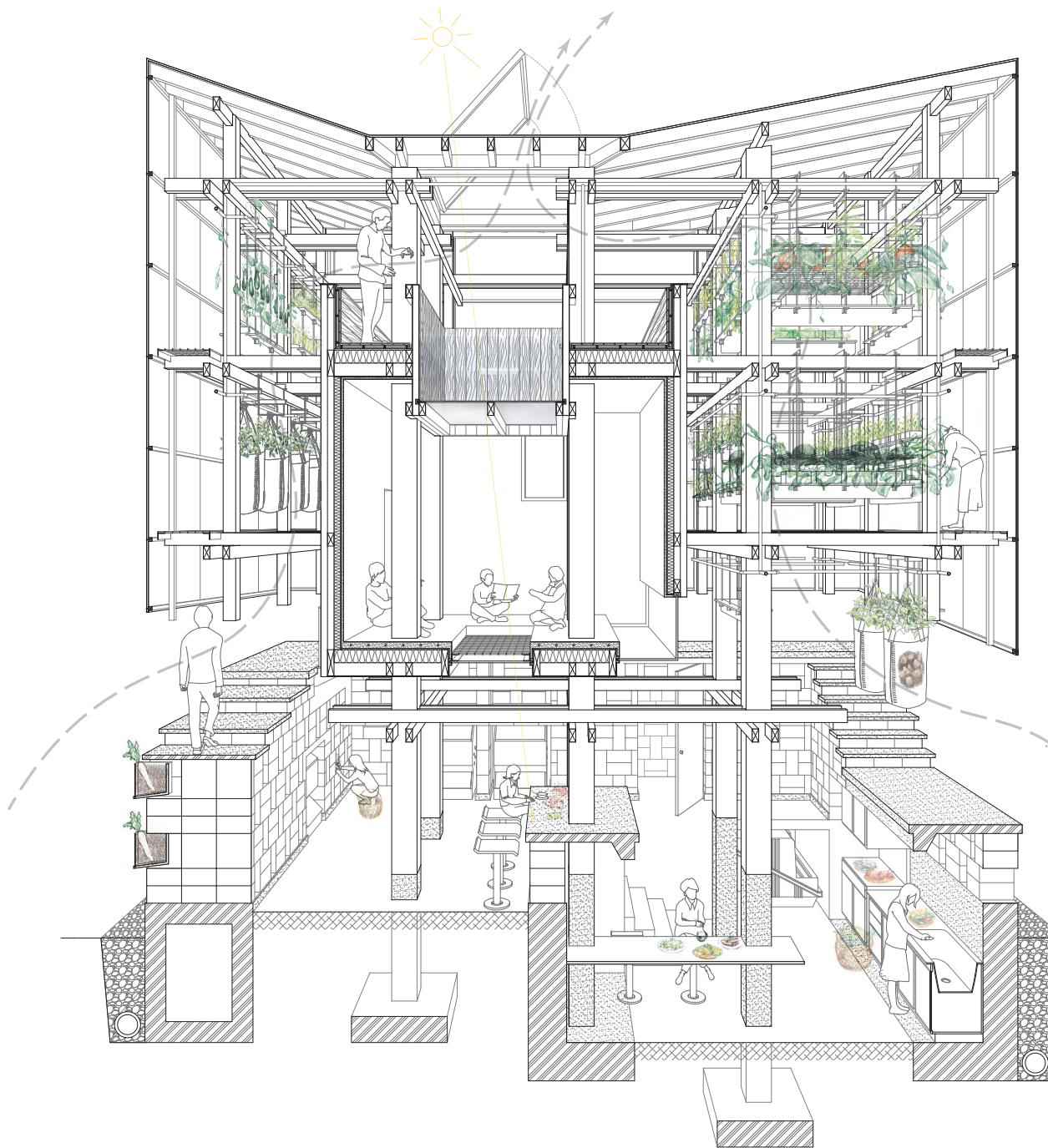
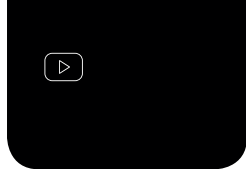

fig 01 (up)

Section of the Nest showing food cycle © UC Berkeley, KKAA

fig 02 | 03 (right)

02. Local fishermen hanging up salmon to store it with vegetables © Shinkenichiku Sha
03. Interior Tea/ Dining Space © Shinkenichiku Sha



Since 1990, Fina Puigdevall has been managing the Restaurant Les Cols d'Olot, as well as being both the owner and chef of this establishment situated in the mountain range by which it is known and her own birthplace. Fina Puigdevall's cooking conveys much with few elements. When creating the dishes she likes to remove everything that she considers is not essential, while not losing the essential poetry. It is a light and essential style, purified but generous. It conveys sincerity, balance, austerity and naturalness, in an authentic and emotive way, with imagination, intuition and sensitivity. It is a style of cooking which reflects her own way of being.

The culinary proposals which this restaurant offer are rooted in the land and the landscape surrounding it.

For this reason Puigdevall has initiated a process of research and recuperation from the area's traditional vegetable growing. She works with a very particular vision of products which we can find in the Garrotxa area: buckwheat, the Vall d'en Bas potato, sweetcorn, poultry (chicken and duck), "fesols de Santa Pau" (a small white bean), ratafia, the Olot "tortell" (a kind of ring-shaped cake or doughnut), pork and sausages, wild river trout, snails, wild boar, truffles, sweet chestnuts, turnips, wild mushrooms, herbs and even flower.

Les Cols likes to offer the most intimate and familiar food experience but with an up-to-date language.

Nature and landscape are taken as a source of inspiration, adapting the products of the land by giving different meaning and tastes. This philosophy, which has inspired also the architectural refurbishment of the restaurant re-designed by RCR Arquitectes in 2002, is the same that inspires Fina Puigdevall's cuisine.

The project gives great importance to the culinary rituals, conveying the visitors to enjoy each one of the pleasures that surround the tables: the luxury of the light and the silence; the importance of the gesture and the look; the serenity of the atmosphere; the hospitality.



image of courtesy of Fina Puigdevall - Les Cols - ph: Joan Valera

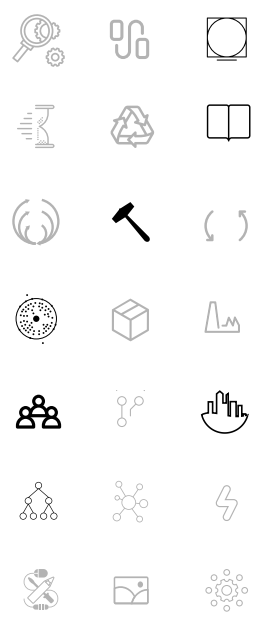
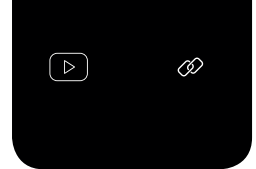

Les Cols

Authors: RCR ARQUITECTES (M. Subirás, J. Padrosa + F. Puigdevall)

Location / Year: Olot, Spain / 2002



CAT 1

CAT 2
DISTRIBUTION
TO CONSUMPTION

CAT 3

cover img

Fina Puigdevall in the restaurant designed by RCR Arquitectes
© Joan Valera

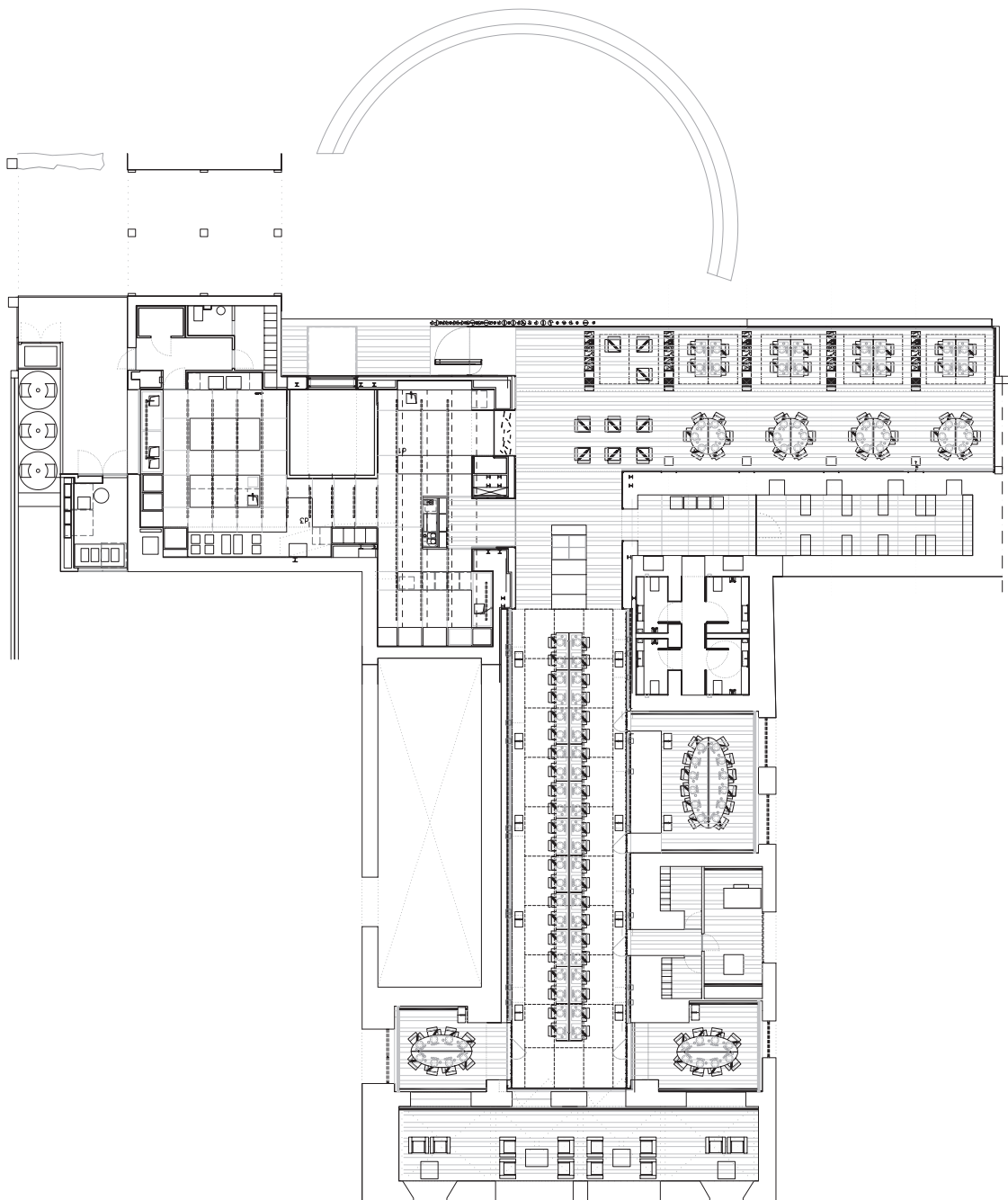

fig 01 (up)

Ground floor plan of Les Cols restaurant
© M.Subirás, RCR Arquitectes

fig 02 | 03 (right)

The new design of the basement is the key-concept
to connect the old farmhouse and the landscape © Eugeni Pons

PROCESS

PRODUCT

MATERIAL

TABLE

KITCHEN

MARKET

MODULE

BUILDING

INSTALLATION

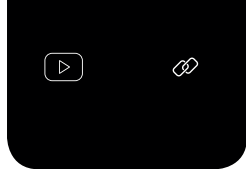

From Chinese dumplings, Japanese ramen, and Italian pasta, to Mexican tortillas and French breads, flour plays an important role in our civilization and supplies us energy as a staple food across culture and history.

To Italian, the geometry of pasta carries both functional and aesthetic meanings. Different sauces ought to be paired with different shapes. Numerous geometries of pasta allow different absorption rates of sauces, provide distinct mouth-feels, and carry unique aesthetic and culture values. However, we know that flat pasta can save more packaging and shipping spaces compared to 3D ones. For example, comparing flat pasta with macaroni, flat pasta can help to save 67.3% of the packaging space. Additionally, thin and 3D-shaped pasta is fragile during shipping. Here we propose a shape-changing concept for the food industry, where edible materials are manufactured into highly compact 2D segments and transformed in the kitchen or on the dining table into 3D structures. This concept enables the company to benefit from low shipping costs due to the compactness of the 2D segments, while ensuring the functions of the 3D end products are uncompromised.

Under a research grant provided by the Italian leading pasta manufacturer - Barilla, we developed a few types of morphing pasta, including helical shapes, thin-hairs, saddle shapes and a few others. In one weekend, we went on a hiking trip with the morphing pasta. We cooked and ate the pasta into the woods. When possible contexts were brainstormed for the pasta, outdoor activities (e.g. hiking) that have constraints in packaging space were brought up as great use cases. We dreamed of shape-changing pasta to be brought into outer space one day, as packing space becomes even more precious for space travels. Additionally, the method could be accomplished through digital fabrication by understanding the material compositions and mechanical behaviours as well as supporting personalization for everyday life. Shape-changing pasta can become a bridge to encourage participative innovation, as well as benefit food distribution to consumption under the food cycles concept.

* **Morphing Matter Lab** members are: Ye Tao, Youngwook Do, Humphrey Yang, Catherine Mondoia, Jianxun Cui, Guanyun Wang, Wen Wang, Prof. Lining Yao. The research was conducted pursuant to a grant from Barilla G. & R. Fratelli, Italy



image of courtesy of Morphing Matter Lab

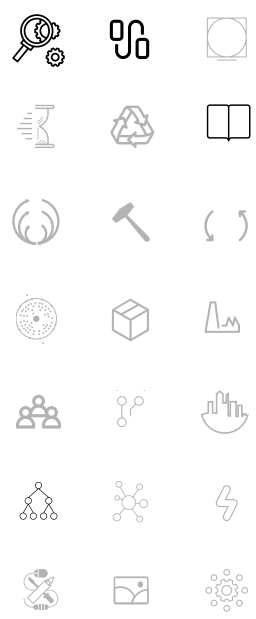
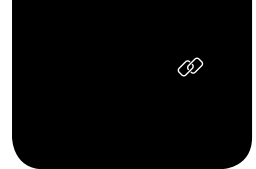

Shape Changing pasta

Authors: MORPHING MATTER LAB*

Location / Year: Carnegie Mellon University - Pittsburgh, USA / 2002

- PROCESS
- PRODUCT
- MATERIAL
- TABLE
- KITCHEN
- MARKET
- MODULE
- BUILDING
- INSTALLATION

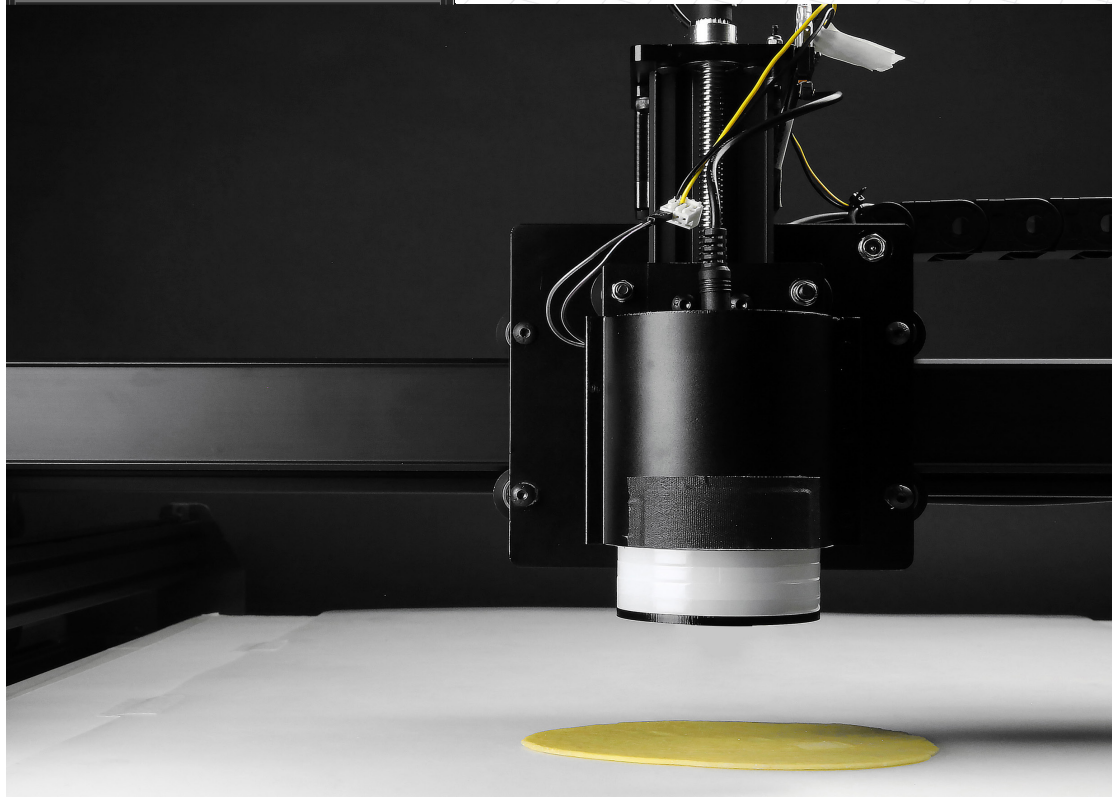
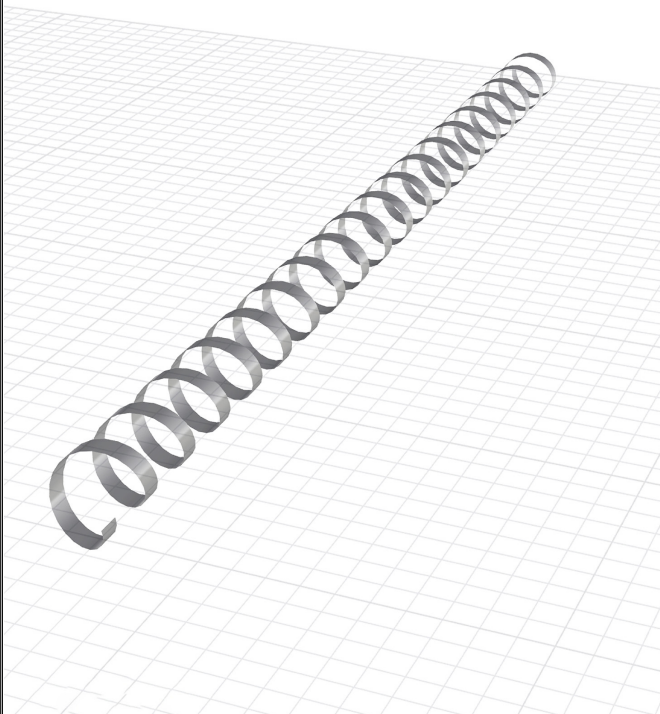
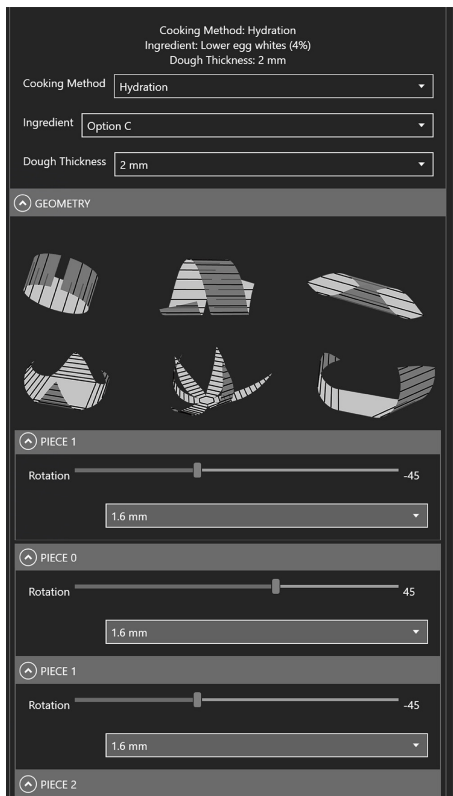
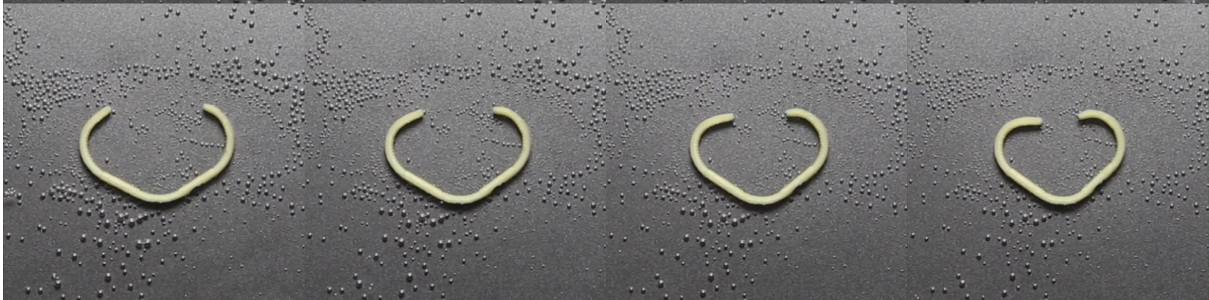

fig 02 | 03 (up and right)

A computational design tool defines the variables of transformation for the digital fabrication process of the pasta
© Morphing Matter Lab, CMU



The supermarket company Mpreis since 1980 established innovative architecture as part of their branding, „seriously sexy supermarkets“ is the statement from Wallpaper magazine. In the perspective of people living in Tyrol –the Austrian region where Mpreis have a network of 270 supermarkets with 5900 employees and an annual turnover of 870 mil. Euro– these supermarkets are part of the quality of living in the region and places of everyday life.

Regionality, in terms of regional products and of a scaled system of markets from urban to peripheral towns in the valleys, and sustainability have become key-aspects of the brand. Everyday aesthetics, spatial atmosphere, quality of materials, energy and life-cycle management of the buildings and the range of regional products have made Mpreis markets important cultural landmarks in Tyrol.

The recent project of Mpreis supermarket in Innsbruck quarter of Wilten, designed by Silvia Boday Office pushes this philosophy even further.

The clear location in the middle of urban life provides a blueprint for an innovative concept for supermarket: as part of urban pattern, as symbol of adaptiveness, and a catalyst of new community experiences, such as foyer, reading room, café, guest garden as urban interfaces.

The great challenge of this project was to combine the different and connected existing buildings and the new extension into a coherent space.

The main role is played by a continuous floor covering of ornamental tiles, which allows the rooms of different characters, shapes and heights to become a whole.

To some extent, the tendril pattern can also be found on walls and ceilings, giving the market a very special atmosphere that is reminiscent of a Mediterranean market hall in the interaction of the colours and the food stands. A glass pavilion was placed at the front of the existing building, in which the newly designed entrance area, protected by a canopy, and a now spacious and light-flooded café and reading room are located.





Mpreis Franz-Fischerstraße

Authors: Silvia Boday Architects

Location / Year: Innsbruck, Austria / 2015

CAT 1

CAT 2
DISTRIBUTION
TO CONSUMPTION

CAT 3

- PROCESS
- PRODUCT
- MATERIAL
- TABLE
- KITCHEN
- MARKET
- MODULE
- BUILDING
- INSTALLATION

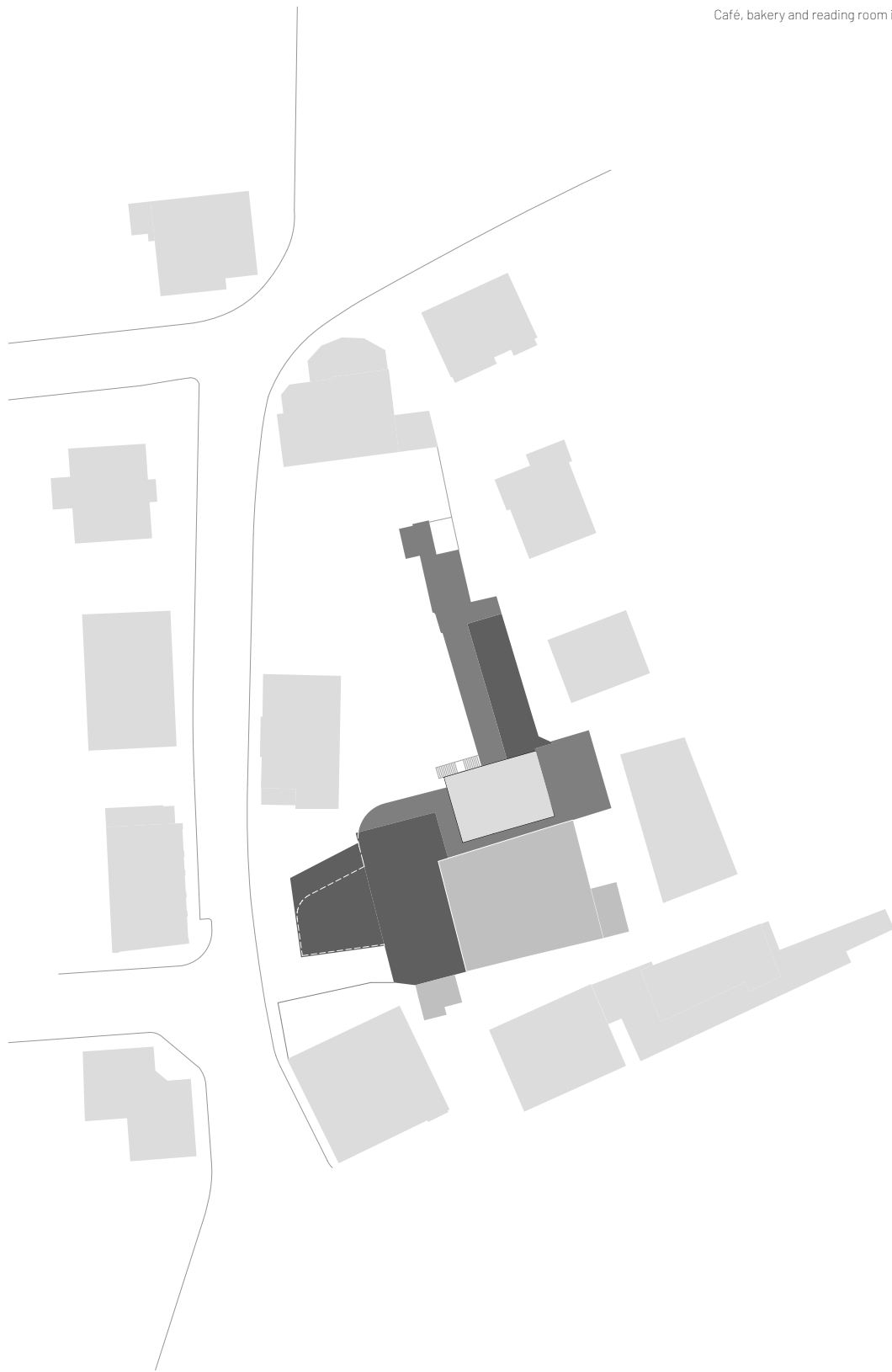
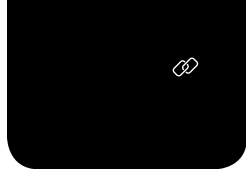

fig 01
General layout plan with the MPreis extensions
in relationship with the surrounding historical context
© **Silvia Boday**

cover img

Café, bakery and reading room in the new pavilion
© **David Schreyer**

fig 02 | 03 (right)
In- and outdoor impressions of the new
MPreis pavilion in Innsbruck Wilten
© **David Schreyer**



Made in Cloister is a cultural-art-exhibition centre in Naples that seeks to create a unique place for the whole city. Specifically, it addresses the urban regeneration process in the neighbourhood of Porta Capuana, starting from the location of the Cloister Santa Caterina a Formiello.

The restoration of this abandoned cloister, originating from the 16th century structure and reused as a cloths-production factory in the 19th century, is realised by the Foundation Made in Cloister. Since 2016 the Cloister is open again to the city.

Made in Cloister aims at a creative future for an important part of Naples' cultural heritage, raising awareness on the social impact of urban regeneration programmes. The main goal is to revisit local traditional artisanal crafts matching them with international artists in common creative processes.

Besides exhibitions and concerts, the Foundation organised some events based on the concept of hospitality and food, as a crucial part of the tradition in Naples and as an additional means of support to create a community and to give new life to the neighbourhood.

One example is the FUD project that promotes artisanal quality production from the whole Campania region, constituting an excellence in the field of food processing and biodiversity preservation. This approach of "nutrition not consumption" transforms the Cloister in temporary market and repositions food as an innovative part of urban culture and creativity.

The project aims to create new ways to connect producers and final consumers. An agri-cultural Action that operates in a healthy and social-equality awareness campaign.

In 2018, the Foundation promoted an exhibition by the artist Mimmo Paladino: Pane e Oro. The exhibition offers a reflection on a dimension that has always accompanied and distinguished man: gift, communion, hospitality, which are rituals connected to the meaning of food sharing. Not just in terms of eating, but also as a spiritual and a cultural act. For this exhibition, Paladino produced a long table engraved with symbols, serving as a social table for the neighbourhood.

image of courtesy of Made in Cloister_ph: Valeria Laureano

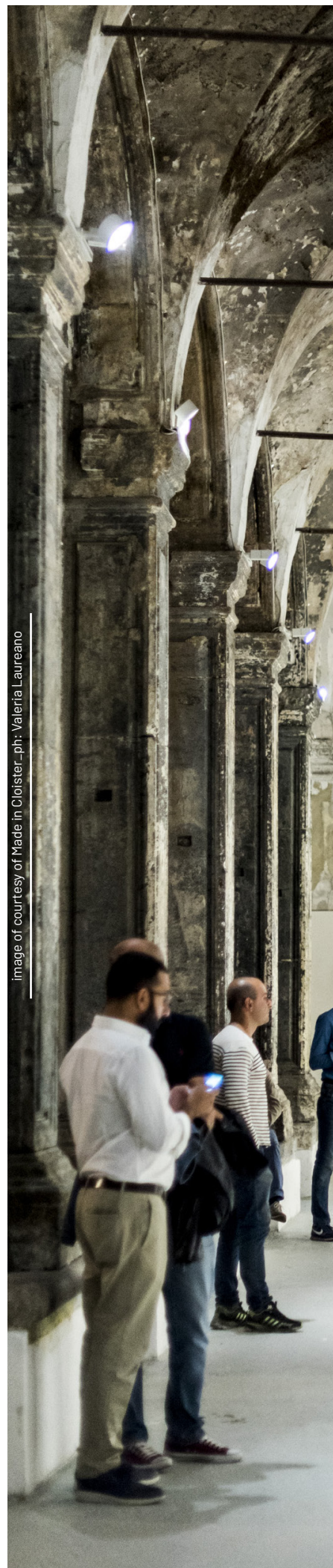

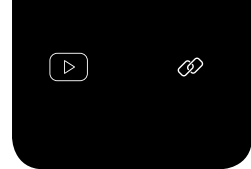

Fud - Made in Cloister

Authors: Rosa Alba Impronta + Davide De Blasio

Location / Year: Naples, Italy / 2016

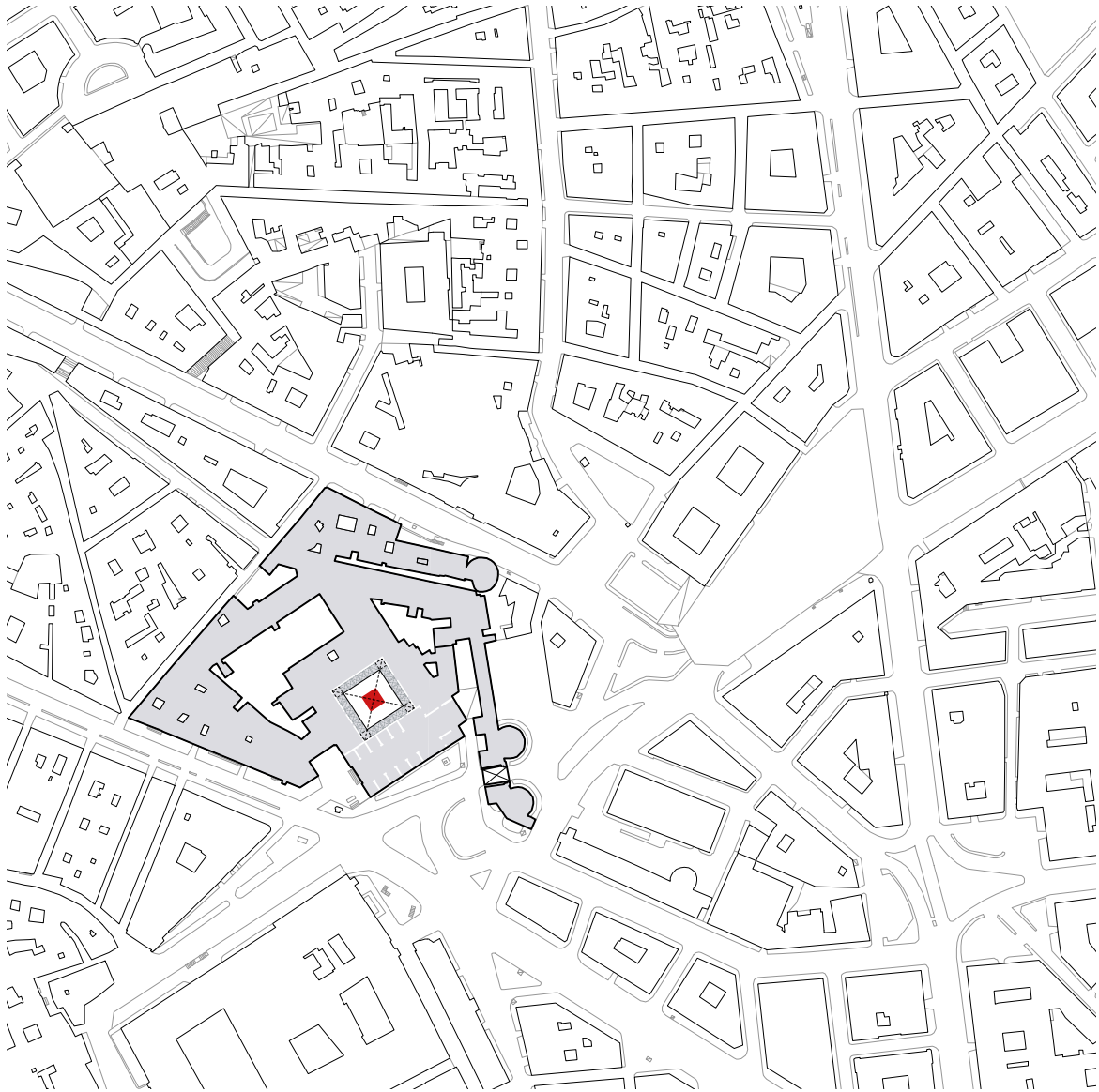

fig 01 (up)

Layout plan of Santa Caterina a Formiello and Porta Capuana, Naples historical centre. Illustration by Sabrina Sposito (adapted from © Municipality of Naples, aerial photogrammetric survey 1:1000 of 1992, Italian Open Data Licence).

fig 02 1 03 (right)

02. FUD © Gilda Valenza
03. Manifesto of the Exhibition "Pane e Oro" by Mimmo Paladino at Made in Cloister © Flavio Arensi



MIMMO PALADINO PANE E ORO

a cura di Flavio Arensi

FONDAZIONE MADE IN CLOISTER
DAL 1 GIUGNO AL 15 SETTEMBRE 2018

Bergen's fish market has always had an important presence for food trading and fishing in the history of the city, going back to the time of its foundation in 1070 and then serving as bureau city of the Hanseatic League.

As a lively marketplace between the fjords and a meeting place for merchants, farmers, fishermen and citizens, it marks its central role upon the city just as well as the historic monuments do. The new fish market, designed by Eder Biesel Arkitekter, caters all year round to clients and visitors as one of the most significant tourist attractions. It therefore needs to provide levels of convenience and hygiene that require a permanent structure, addressing all the aspects of the food cycle in this specific place of Bergen old town.

The building, located in the very middle of the world cultural heritage "Bryggen", blends into the historical context, by adopting a contemporary architectural language. The lines of sight from the Almenning roads towards the harbour as well as the lines of sight to the other urban landmarks define the visual limit of the property.

Maintaining those is essential for experiencing the urban context around the historic bay. From a pedestrian's point of view, the food hall stretches along the quay and has an open ground floor, retaining the contact between the streets and the water, determining the connection towards the historical urban space.

The concept does not aim at creating an interior design, but instead at providing a climatizing protection for the fish market that makes limits between market place and market hall disappear, promoting free interaction between clients, visitors and operators.

The transparent glass façade on the ground floor continues to provide the view to the harbour, while offering protection during cold winter days. The floating volume which gives shelter to the marketplace hosts on the first floor a museum, a tourist info-point and the "Norwegian Sea Food Centre". The volume serves also as a public space with panorama views towards the historic centre of Bergen.

Image: courtesy of Eder Biesel Arkitekter - ph: Norbert Miguletz

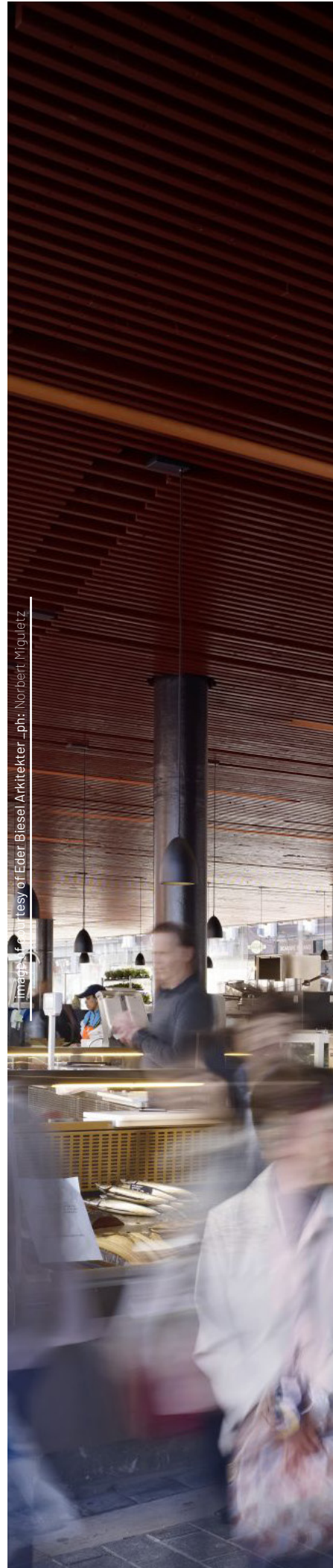

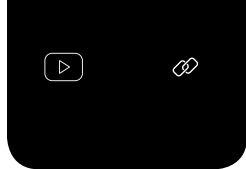

Fish Market

Authors: EDER BIESEL ARKITEKTER
Location / Year: Bergen, Norway / 2012



CAT 1

CAT 2
DISTRIBUTION
TO CONSUMPTION

CAT 3

cover img

The fish market as public space
between the old town and the harbour
© Norbert Miguletz

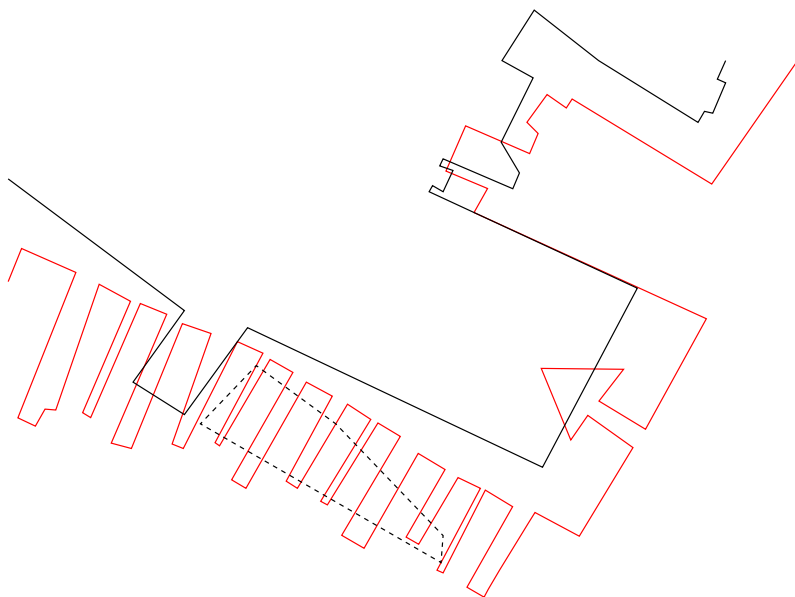

Waterfront today —
Waterfront from 1664 to 1880 —

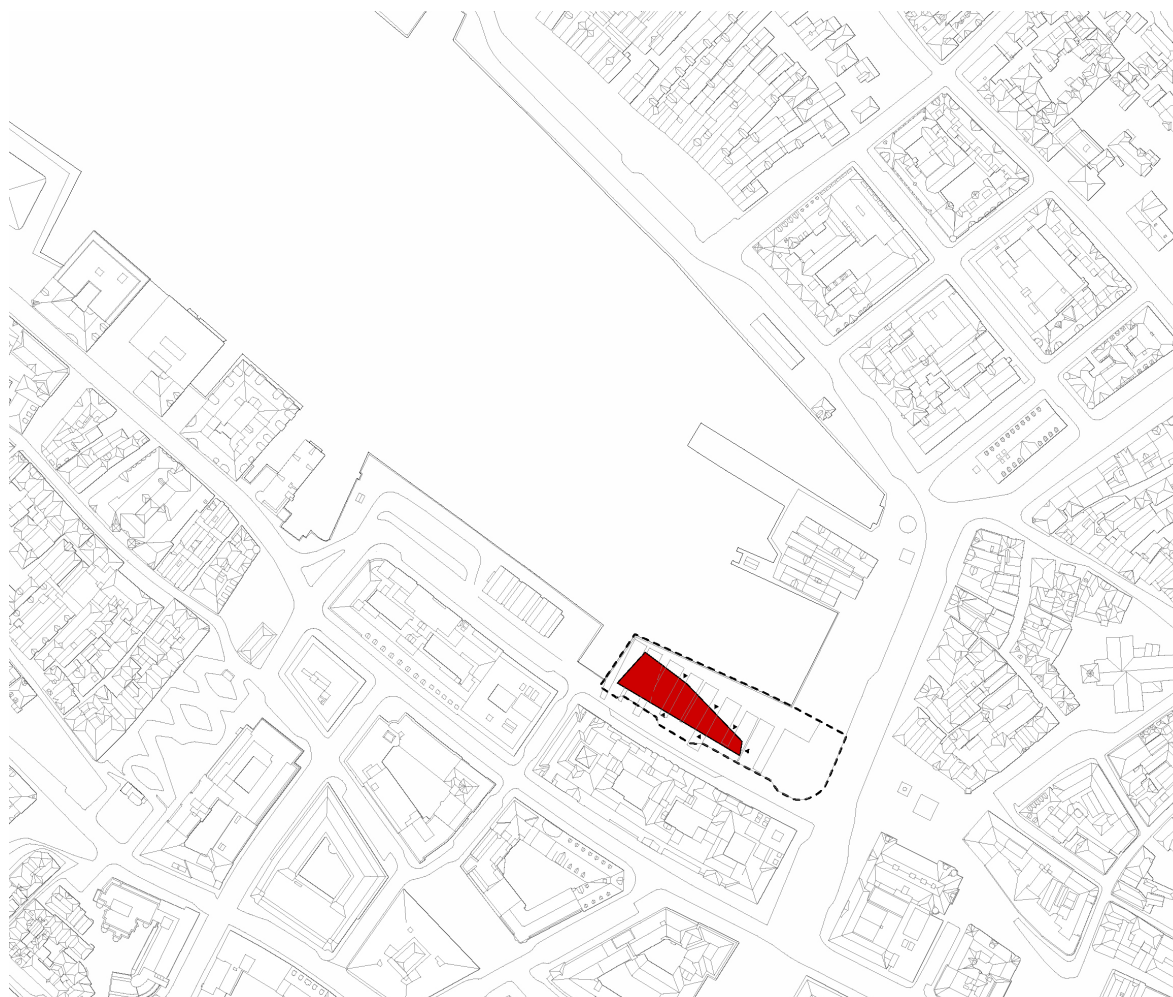

fig 01 (up)

Form-finding diagram & layout plan of the Fish Market
© Eder Biesel Arkitekter

fig 02 | 03 (right)

Impressions of the Fish Market in its urban context in the harbour
© Norbert Miguletz

PROCESS

PRODUCT

MATERIAL

TABLE

KITCHEN

MARKET

MODULE

BUILDING

INSTALLATION



In order to upcycle an unused space between buildings in Fukuoka, Notes Architects created a low-cost stand that enables a local coffee shop to be open on weekdays. The do-it-yourself design and low manufacturing cost are the basic principles that inspired the project, consisting of 17 panels made up of square timbers and plywood.

The construction concept was inspired by food stalls, called "Yatai", and is based on the idea that a primary function of such stalls is to be portable: easy to set up when shops open and easily removed again when they close. The Yatai, which are small, movable eating and drinking establishments, are currently popular in Japan in the trend of the bottom-up architectural movement.

Especially young architects, aiming for regional contacts, have taken Yatai as new tools to effectively make good use of Japanese urban space. The Yatai originated from the Edo period (1603-1868) providing a simple food option for samurai, peasants and courtiers that often travelled between the capital city and their feudal territories (Han). They have been re-introduced after WWII and then spread throughout Japan. However, most of them disappeared gradually during the Tokyo Olympic Games in 1964. Regulation became stricter due to hygienic concerns.

In Japan, opening an indoor shop needed to meet the criteria of both the Building Standards Law and the Food Sanitation Law. Building a moving sales vehicle, permit to overcome the restriction of Building Standards Law. In order to resolve the conflict with Food Sanitation Law, Notes Architects created a new format that would allow coffee to be served as an accompanying drink of an already approved food item. This enables a cafe to open a coffee stand as an approved business. Under the current circumstances, many public spaces are not effectively used in Japan, even though they could be re-activated by implementing existing regulatory restrictions as design opportunities.

Notes Architects, taking the inspiration from original Yatai, provides with Bonnie Coffe stand a quick experiment in the frame of maker actions. It might contribute to design a long-term vision based on food and creativity for urban neglected spaces in Japan.



Image of courtesy of Note Architects, ph: Maki Hayashida

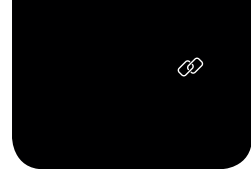

Yatai Cart

Authors: NOTE ARCHITECTS (Ryo Kamamatsu)

Location / Year: Fukuoka, Japan / 2018

CAT 1

CAT 2
DISTRIBUTION
TO CONSUMPTION

CAT 3

cover img

Bonnie coffee's Yatai Cart in the renovated alley by Note Architects
© Maki Hayashida

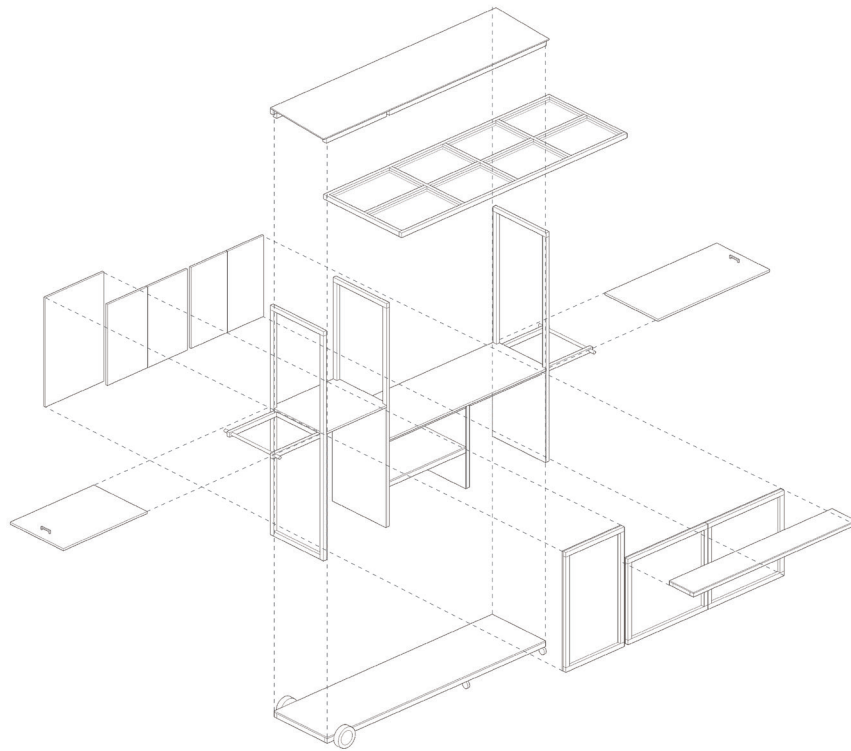
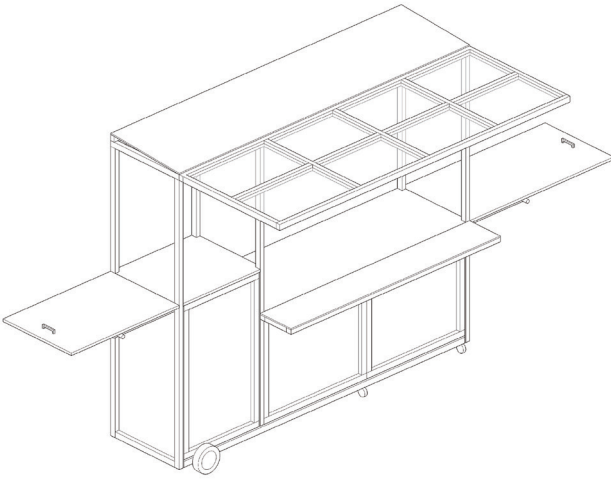

fig 01

Exploded axonometric view of the Yatai Cart
© Note Architects

fig 02 | 03 (right)

The Yatai Cart as movable coffee stand
© Maki Hayashida & Note Architects

PROCESS

PRODUCT

MATERIAL

TABLE

KITCHEN

MARKET

MODULE

BUILDING

INSTALLATION

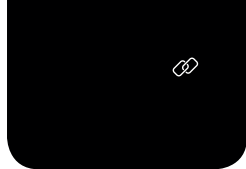

Fishing is one of the oldest industries in Worthing. Nobody has yet recorded or preserved the history of this once thriving trade, which gives The Last Fisherman Standing the opportunity to make sure that southern Britain fishermen's tales and knowledge do not disappear. Since the introduction in 1970 of the EU Common Fisheries Policy's management of fish stock and quotas, have tightened sustainable local fishing activities in UK. In early 2000 the idea of sustainable seafood came to the fore, catching fish and harvesting shellfish in ways that consider the long-term perspective and the health of the seas become a more and more sensitive topic for small fishing communities, like in Worthing.

The last full-time fishermen have stopped working on Worthing's beach in 2015, and their heritage along with their small scale fishing techniques represents the most significant record to be shared among the town's long time fishing families.

For this reason, the non-profit organization We Are FoodPioneers CIC, working with regional and national partners to build community through shared food experiences and funded by Heritage Lottery from 2016 to 2018, launched the social awareness campaign project "Last Fisherman Standing" in order to explore the local fishing heritage along British coasts.

The project includes a schools outreach programme, a fishing pop-up museum, an exhibition trail as well as sculptural interpretation classes along the seafront.

Last Fisherman standing offers also monthly fish cookery courses, with people being able to get involved by learning how to prepare and cook different types of fish sourced from fishermen in Sussex.

As a disappearing industry, it is vital to ensure that this project captures, shares and preserves Worthing's fishing heritage to generate greater awareness and appreciation of the wealth of the fishing heritage, a stronger involvement with and celebration of the work of the fishermen.

Image of courtesy of Food Pioneers. ph: Miles Davies



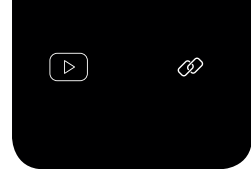

Last Fisherman Standing

Authors: FOOD PIONEERS (Fran Corney + Anne Thwaites)

Location / Year: Worthing, UK / 2016

CAT 1

CAT 2
DISTRIBUTION
TO CONSUMPTION

CAT 3

cover img

Fisherman at the beach of Worthing
© Miles Davies

PROCESS

PRODUCT

MATERIAL

TABLE

KITCHEN

MARKET

MODULE

BUILDING

INSTALLATION



fig 01(up)

Last Fisherman Standing Logo for slow fish social awareness campaign
© Tom O'Boyle

fig 02 | 03(right)

Direct fish-selling on Worthing's beach and historical construction of wooden fisher-boats
© Worthing West Sussex Library Service. © Worthing Museum & Art Gallery

