

2nd International Conference on System-Integrated Intelligence: Challenges for Product and Production Engineering

Sensor integration for a hydraulic clamping system

Berend Denkena, Dominik Dahlmann, Johann Kiesner*

Institute of Production Engineering and Machine Tools (IFW), Leibniz Universitaet Hannover, An der Universitaet 2, 30823 Garbsen, Germany

Abstract

Failures in workpiece positioning influence the machining conditions and outcome of machine tools directly. Hence, the monitoring by a sensor integrated clamping system to avoid rejects is subject of the presented work. The overall aim is to integrate sensory capabilities in a hydraulic clamping system typically used in series production within a joint research project. This paper gives a general survey of the targeted application and focuses on the sensor integration. It shows the qualification of strain gauges for indirect measurement of oil pressure in the hydraulic clamping element and the potential use of the same strain gauges to measure further monitoring objectives.

© 2014 The Authors. Published by Elsevier Ltd. This is an open access article under the CC BY-NC-ND license (<http://creativecommons.org/licenses/by-nc-nd/3.0/>).

Peer-review under responsibility of the Organizing Committee of SysInt 2014.

Keywords: strain gauges; sensor integration; hydraulic clamping-elements; hydraulic swing clamp; clamping system; condition monitoring

1. Introduction

Clamping systems hold the workpiece in a defined position in the working space of a machine tool. Hence, positioning failures directly influence process behavior and machining results. Approximately 40 % of rejects are due to dimensioning errors that are attributed to poor fixture design [1].

The design and fabrication of a clamping fixtures can take up to 20% of the total manufacturing cost [1-3]. Its quality often relies on the designer's experience and is based on his understanding of the product. To reduce this reliance, but still provide a reliable clamping, much research effort has been focused on computer aided manufacturing. A good survey of recent research and trends in computer-aided fixture planning (CAFP) and design (CAFD) are given in [1] and [3-4]. Most of the CAFP/CAFD methods have the aim to determine accessible and

* Corresponding author. Tel.: +49-511-762-5210; fax: +49-511-762-5115.

E-mail address: kiesner@ifw.uni-hannover.de

collision free locations of fixture points that ensure part immobility under the application of external forces and moments. Boyle et al. conclude that many of the CAFD approaches have been tested for simple workpieces that are unrepresentative of those encountered in industry, thus the effectiveness of developed techniques cannot be stated with confidence [4]. On this account, despite the accurate effort in the phase of fixture planning and designing, malfunction or failure during machining cannot be excluded.

Nevertheless, to ensure a reliable and sustainable manufacturing, different developments were done to enable machine components to monitor the machining processes [5-7] and to interact with manufacturing processes by using mechatronic systems [8]. Nee et al. [9] present a prototype intelligent fixture which is capable of improving machined workpiece quality by controlling the clamping intensity. For the measurement of the clamping force, a direct sensing method with piezo-electrical force sensors was used. The direct monitoring methods can achieve a high accuracy, but due to numerous practical limitations, they are characterized as laboratory oriented techniques [10]. To enable suchlike applications in industrial environment, sensor systems are needed, that are more suitable for practical applications, at machine shop level.

An advantageous approach is presented by Litwinski [11] by integrating an intelligent sensor system into already existing components of a machine tool. He investigated a modular clamping system within the Collaborative Research Centre 653. The system determines the potential use and performance of a manual sensory clamping fixture for machine tools, but regarding the robustness it is not suitable for industrial use yet. The system is characterized by integrated sensors for measuring cutting forces as well as accelerations and temperatures. The collected information allow conclusions on the current process state and the detection of process failures. The use for process monitoring offers outstanding performance, therefore, the system is being transferred from research to industry within a joint research project.

The aim is to develop a hydraulic clamping system, which is typically used in series production, with sensing capabilities in cooperation with two partners from industry, a clamping technology manufacturer and a fixture construction service provider. Error conditions such as wear, overload, incorrect setting and improper use should be recognized to enable process and condition monitoring. In addition, the sensor integration, high system robustness, power and data transfer to rotating systems and the consideration of cost aspects set special requirements to the application in an industrial environment.

At first, this paper gives an overview of the overall concept and then focuses at the integration of strain gauges into hydraulic swing clamps to provide the fixture with sensing capabilities.

2. Overall concept

The development of the sensory clamping system is carried out on the basis of a representative application scenario. It deals with the hydraulic clamping for multi-axis machining of cast casing covers.

The simplified system structure is shown in Fig. 1a. The exemplary hydraulic clamping fixture (see Fig. 1b) is an assembly which consists of a fixture plate, three hydraulic swing clamps with appropriate supports and one hydraulic work support. The supply of oil for the hydraulic clamping elements within the fixture is realized by drilled hydraulic lines inside the fixture plate.

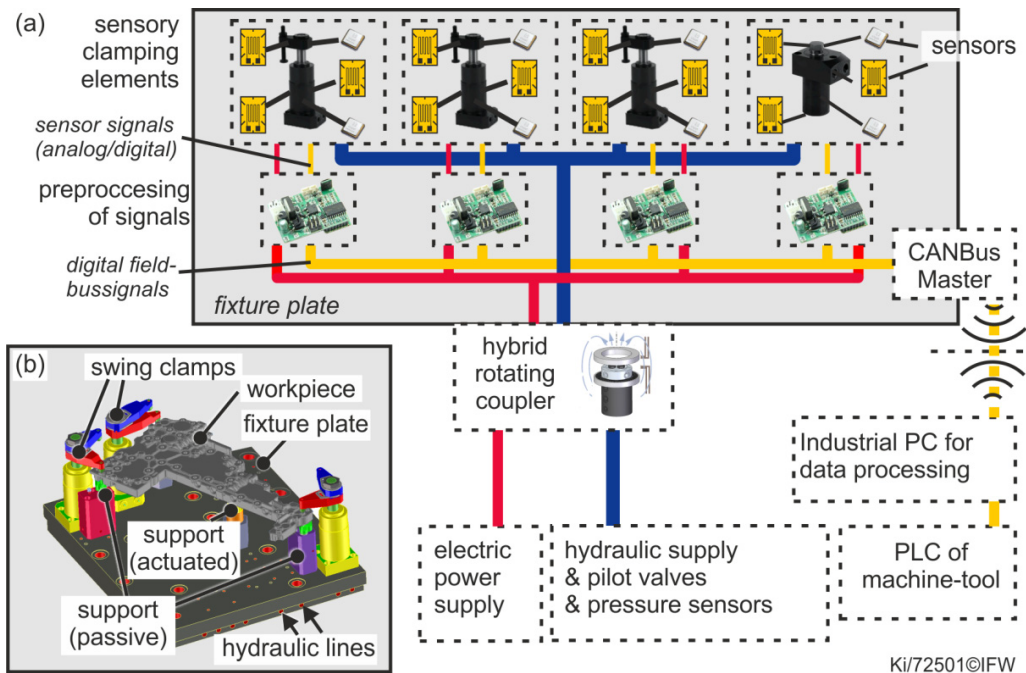

Fig. 1. (a) system overview; (b) hydraulic clamping fixture.

The realization of a sensing clamping fixture will be achieved by the sensor integration into the hydraulic clamping elements. Intended quantities for measurement are strains, accelerations and temperatures. Every sensory clamping element possesses an embedded micro-controller based hardware for signal-preprocessing. This serves several purposes: the shortening of susceptible analog transmission paths by digitalization close to the sensors, and the connection to a common fieldbus to enable communication abilities. In this way, it is possible to expand the clamping fixture by additional sensory clamping elements with little effort. The transfer of the sensor information to an industrial PC for central data processing is established by an additional fieldbus participant via a radio link. For the communication with the PLC of the machine-tool, e.g. to send status information, the industrial PC is provided with a PROFIBUS-interface.

To enable the multi-axis machining the fixture has to be mounted on a rotary table. Therefore, a hybrid rotary coupling is used to supply the fixture with electric and hydraulic energy. This unit is a combination of a rotary coupling for hydraulic oil and induction coils for a contactless, inductive energy transfer. A typical voltage of 24 V DC is used and converted into AC voltage for the primary induction coil by an embedded circuit board.

3. Sensor integration

3.1. Monitoring objectives and error conditions

The main task of hydraulic clamping elements is to convert hydraulic energy into mechanical clamping force. Hence, the actual present oil pressure inside the clamping chamber directly influences the clamping force. This principle is well known and used in hydraulic clamping systems for setting the clamping force by controlling the operating pressure at the hydraulic pump to a desired level. During the period of use different error conditions, e.g. leakages at hydraulic connections and blocked-up hydraulic lines, arise that cause oil pressure differences in the hydraulics.

Further error conditions that are reducing the lifetime of clamping elements result from incorrectly set parameters at the hydraulic supply. On this account, excessive flow rates and pressures must be avoided. Hence, to guarantee an

appropriate clamping force before processing it is useful to monitor the oil pressure and the pressure build-up time at the clamping element. Exemplary curves for an ideal pressure build-up and impermissible deviations are illustrated in Fig. 2a.

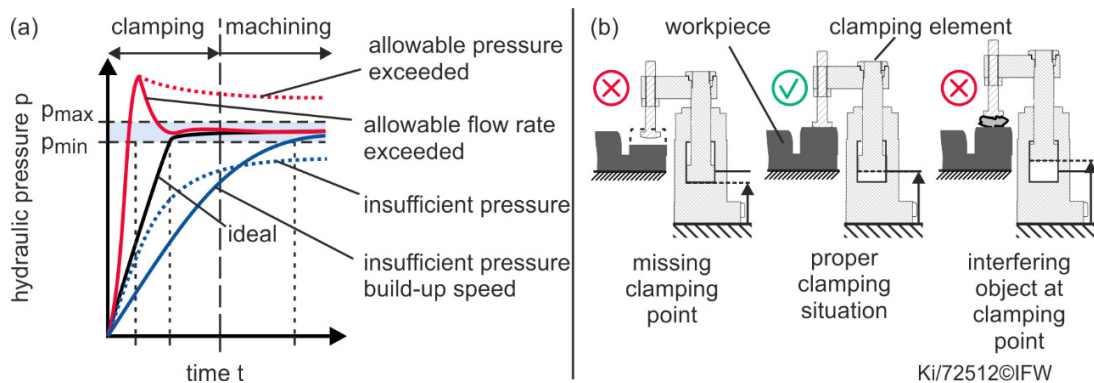

Fig. 2 (a) ideal and incorrect pressure build-up (b) piston position at different clamping situations.

Despite of an adequate designed hydraulic supply, further failures in the clamping situation occur due to external reasons like wrong geometries or interfering objects, e.g. milling chips at the clamping point. These effects are often accompanied by a varying piston position (see Fig. 2b). Therefore, the following section presents a sensor concept to enable space-saving pressure measurement and piston position estimation.

3.2. Concept for sensor integration

To provide the hydraulic swing clamp (see Fig. 3a) and the hydraulic work support (see Fig. 3b) with sensing abilities, strain gauges are being integrated into the hydraulic clamping elements. The following considerations towards sensor placing are related to the swing clamp.

The used hydraulic swing clamp is a double-acting clamping element with a bottom flange. The piston is constrained by a mechanism to fulfill a defined swing movement during the first half of the total stroke. The rest of the downward movement is useable for clamping. The swing clamp can roughly be summarized into the main components: the clamping arm assembly, the piston with the piston rod and the cylinder as shown in Fig. 3a.

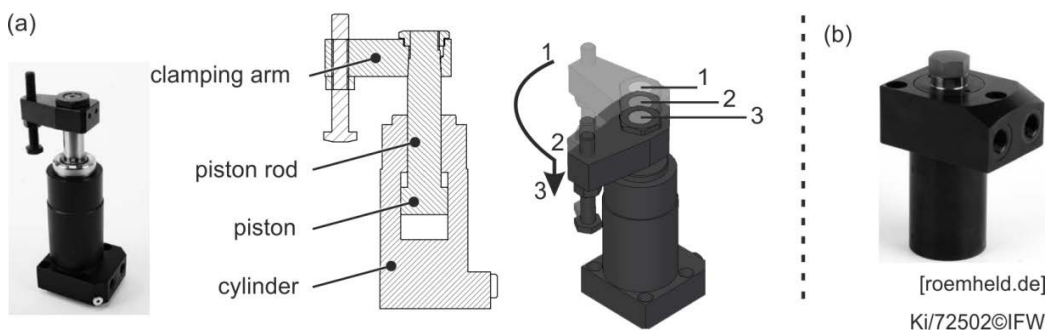

Fig. 3. (a) hydraulic swing clamp (b) hydraulic work support.

Referring to the investigations of Litwinski [11] and the experiences of the industrial partners the maximum strains while clamping a workpiece occur in the clamping arm assembly and the piston rod. Despite the achievable sensitivity, these components are not suited for the sensor placing. One reason to avoid sensor application at the clamping arm is the fact, that standard clamping arms are rarely used in industrial practice. Due to the available

space on the fixture plate, which is strongly limited in most cases of series production, clamping arms have often to be designed individually for different clamping tasks. Another reason concerns the reliability and robustness in harsh environmental conditions. For the sensor connection a flexible cable routing would be necessary, which is susceptible to damage. Therefore, the cylinder of the swing clamp is chosen for further investigation towards sensor integration. To protect the mounted sensors against mechanical influences, e.g. cooling lubricants and chips, a cylindrical protective cover can be used advantageously. Same considerations concerning the moveable components of the clamping element apply to the hydraulic work support, which will not be discussed further.

Fig. 4 illustrates the concept of sensor integration. For the estimation of suitable sensor positions the finite elements method was used to point out the stress distribution in a simplified geometry of the swing clamp. Therefore, different conditions were simulated.

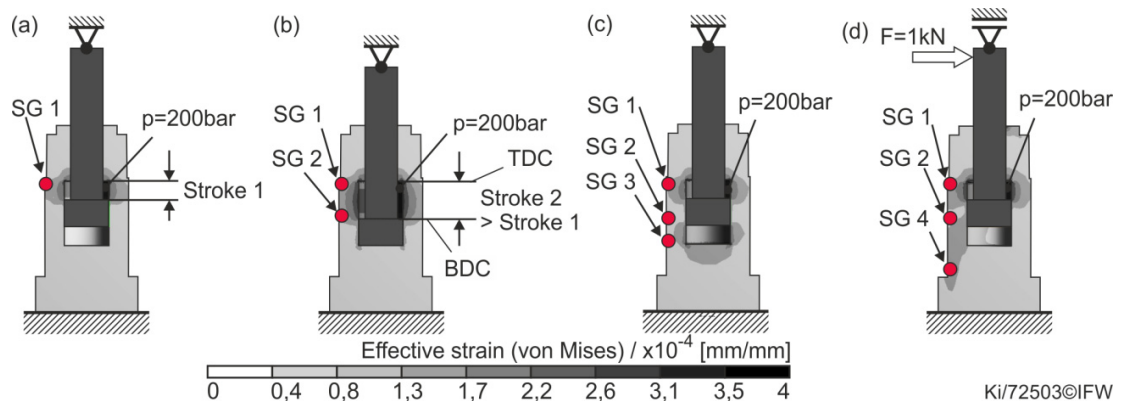

Fig. 4. Strain distributions in the hydraulic swing clamp.

One way to acquire the hydraulic pressure inside the cylinder is the measurement of those strains, which are caused directly by hydraulic load. Therefore, it is reasonable to place the strain gauge in the region of the biggest local deformations due to the hydraulic pressure. For the acquisition of strains even at small strokes the strain gauge is placed at the level of the top dead center (TDC) of the piston, see Fig. 4a.

The stress distribution in the clamping element, which results directly from the hydraulic pressure, varies with the executed stroke. Increasing strokes lead to an amplification of the strains in the lower part of the cylinder as depicted in Fig. 4b. Because of that, a strain gauge placed at the level of the bottom dead center (BDC) can be used to estimate the position of the piston, e.g. to detect interfering obstacles between the clamping arm and the clamping point of the workpiece. This can only be achieved by a simultaneous evaluation of both sensors to enable the distinction between strains which result from pressure or the executed stroke.

With the evaluation of additional strain gauges further objectives are detectable. An exemplary failure, which occurs in actuated elements, is for instance a blocked oil line that restricts the correct functionality. This results in an increased pressure at the oil return and could be recognized with a strain gauge at the position SG 3 in Fig. 4c.

The last example, see Fig. 4d, shows the strain distortion which results from an additional applied force at the top of the piston rod. Based on the principle of the bending beam, the external force effects a bending load to the cylinder and that leads to an increase of the stresses especially at the bottom part of the clamping element. On this account a strain gauge placed at the position SG4 has the biggest sensitivity toward external forces in comparison to the other marked positions. Furthermore, this example illustrates that the external force never affects only a separated region of the clamping element. The influence on the measured values of the remaining strain gauges is probably unavoidable. Therefore, to attain a substantiated calculation of the present loads or failures it is necessary to conjunct the different sensor signals and ascribe them to their cause. For this purpose it is essential to gain knowledge of the complex stress distortions inside the clamping element, depending on varying conditions.

It is obvious that the number of detectable objectives can be increased by applying additional strain gauges. But in consequence, every additional sensor increases the production costs, the dimensions of the circuited board for the

preprocessing and the failure probability of the sensory clamping element. Therefore it is necessary to find a compromise between a maximum number of sensors and the monitorable objectives.

3.3. Experimental analysis

To verify the concept of sensor integration experimental analysis are being performed. At present, experimental results exist for the concepts according to Fig. 4a/b. Therefore, two full bridge strain gauges were applied to the swing clamp, see Fig. 5a. According to Fig. 4b the lower bridge SG 2 is adjusted at the level of the BDC and the upper bridge SG 1 twelve millimeters above, which complies with the range of the clamping stroke. In the experimental set-up the swing clamp is connected to a hydraulic circuit, which supplies the cylinder with controlled hydraulic pressures. The pressure in the circuit is measured by a common hydraulic pressure sensor and is acquired as an absolute reference quantity together with the amplified signals of the strain gauges. The measurements were done with the operating pressures of 0 MPa, 1 MPa and 15 MPa.

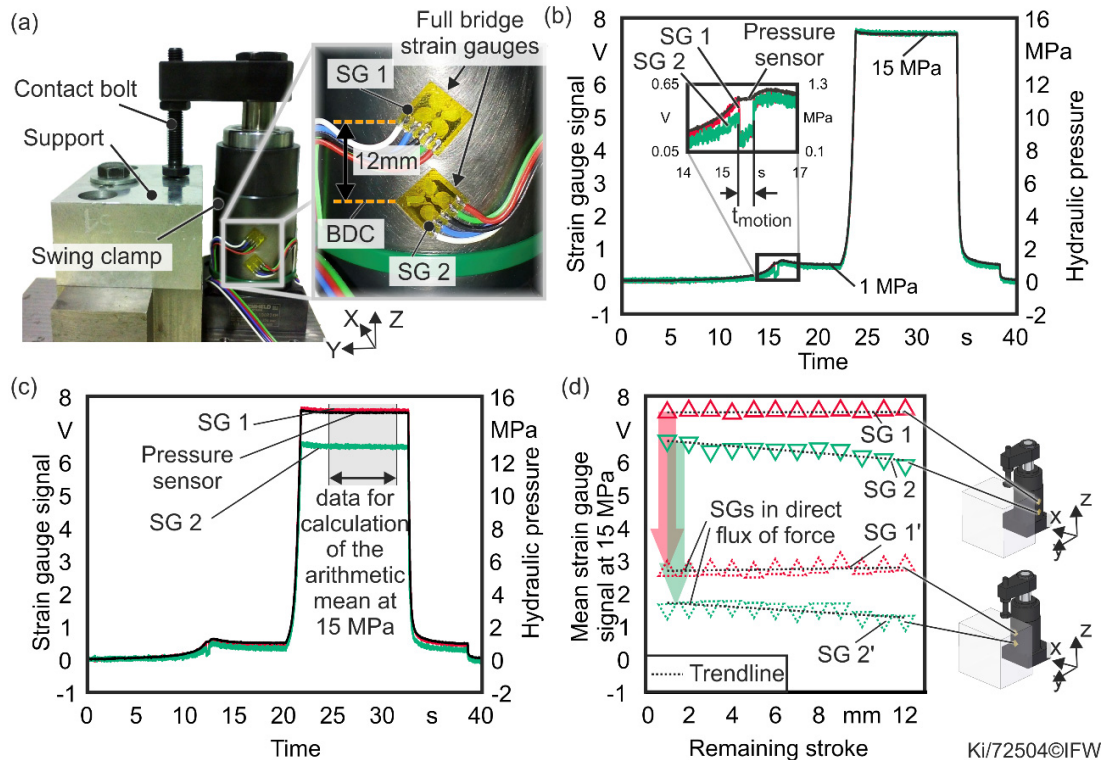

Fig. 5. (a) Test set up; (b) calibration without workpiece; (c) ordinary minimum load collective at remaining stroke of 7 mm; (d) strain gauges vs. remaining stroke.

3.3.1. Calibration

The offset and the amplification of the strain gauges are calibrated to the voltages of 0 V at the hydraulic pressure of 0 MPa and 7.5 V at 15 MPa. The calibration was done without a supporting workpiece, so the piston executed the maximum stroke until the BDC. This way, the deformations inside the hydraulic cylinder results only from the inner pressure of the hydraulic oil and the interaction between the piston and the stroke-limiting bottom of the cylinder. The measured graphs in this scenario (see Fig. 5b) have a high degree of coverage, so that an indirect measurement of the hydraulic pressure is possible, if no other loads effect the stress distribution inside the cylinder. The advantage of the estimation of the hydraulic pressure directly at the clamping element compared to a hydraulic pressure measurement at the supply is demonstrated in the enlarged section. Even momentary local pressure drops during the

swing and downward movement of the piston are measurable with the strain gauges. This feature enables e.g. the monitoring of the time that this piston needs to fulfill the swing and clamping motion. To achieve similar performance with a conventional pressure sensor, it would be necessary to install it very close to the clamping element. That would lead to the disadvantage of a significant loss of constructional place.

3.3.2. Load collectives

In ordinary application the clamping elements are always exposed to load collectives. The minimum number of loads results from the hydraulic pressure inside the cylinder and the clamping force, which is acting at the contact bolt. For this purpose measurements were done with the set-up in Fig. 5a in which the contact bolt presses against a support. Fig. 5c shows exemplarily the result with the end position of the piston at seven millimeters above the BDC. In comparison to the graphs from Fig. 5b it is clear, that the varied load situation does effect the stress distribution at the lower strain gauge, and thereby the signal of SG2 decreases. But it has rarely an effect to the upper strain gauge.

To display the influence of the end position of the piston to the strain gauge signals, a measurement series with a stepwise varied height of the contact bolt to achieve a clamping with different end positions of the piston was performed. For every end position one measurement graph of both strain gauge signals was captured and an arithmetic mean at a constant level of 15 ± 0.01 MPa (see Fig. 5c) was calculated. These mean values are plotted as solid markers over the remaining stroke in Fig. 5d. The curves show the expected development. The variation of the end position does not affect the strains at SG 1, so the curve remains at a constant level. The curve of SG 2 decreases with a higher end position of the piston because of the growing distance to the influenced area of the hydraulic pressure (compare Fig. 4 a/b). The measurements were repeated with a second set-up. Hereby, the orientation of the strain gauges was rotated around the Z-axis by 90 degrees (see Fig. 5d) to expose them to the direct flux of force. The result of this measurement is plotted in Fig. 5d as dotted markers and labeled with SG 1' and SG 2'. The curves have similar trends to the curves of the previous set-up with the difference in their absolute amplitudes, which are shifted to a lower level. This effect results from the deformation of the cylinder due to the external clamping force at the contact bolt. The deformation partially superimposes the stresses at the cylinder surface, which are initiated from the hydraulic load.

In both set-ups the trendlines of SG1 and SG2 do not intersect at the ordinate and at the remaining stroke of zero millimeters, respectively. At a remaining stroke of zero millimeter the bottom of the piston has contact to the stroke-limiting bottom of the cylinder so that the contact bolt does not reach the support (see also Fig. 2b). This situation equals the calibration scenario and the flux of force differs completely from the situation at remaining strokes greater than zero millimeter, due to different contact conditions inside the clamping element. Therefore, sensor signals at zero millimeter are not plotted in Fig. 5d.

3.4. Methods for signal improvement

The use of the additional strain gauge SG 2 (compare Fig. 4b & Fig. 5a) purposes primarily the indirect estimation of the piston position. This is a valuable quantity for the monitoring of a correct executed clamping. It can be used to check the existence of a workpiece or to verify the variations in allowances of casted workpieces.

The results in Fig. 5d point out that the amplitude of the sensor signal SG 2 depends on the executed stroke. But to use this dependency to estimate the position of the piston vice versa, an improvement in form of a steeper curve of SG 2 according to the stroke is necessary. One disadvantage of the used full bridge strain gauges is their dimensions regarding the desired objective. As shown in Fig. 5a, both strain gauges have to be placed very close to each other to center them at the level of the piston for both extreme values of the clamping stroke. Due to the bridge circuit, the lowest measuring grid of SG 1 and the top measuring grid of SG 2, which lie very close together, take always account to the measured values. To achieve a sharper separation smaller strain gauges will be used instead.

A further step toward signal improvement concerns the increase of the sensor sensitivity through the influencing of the force flux by the utilization of the notch effect [13]. A successfully implementation of this method to achieve a sensory z-slide is demonstrated in [12]. Therefore, a notch geometry for the insertion into the clamping element was defined. With the application of strain gauges at the notch base, the local increase of stresses is exploited to improve the sensitivity of the integrated sensor. First simulation results (see Fig. 6) indicates that for the illustrated case a local stress increase of 71 % can be achieved. The negative effect in this case, the weakening of the swing clamp

cylinder by increasing the compliance by 1.3 %, is relatively low. Currently, FEM studies are carried out with a more detailed swing clamp geometry for the purpose of the optimization of the notch dimensions and the determination of further suitable positions on the clamping element for the integration of strain gauges.

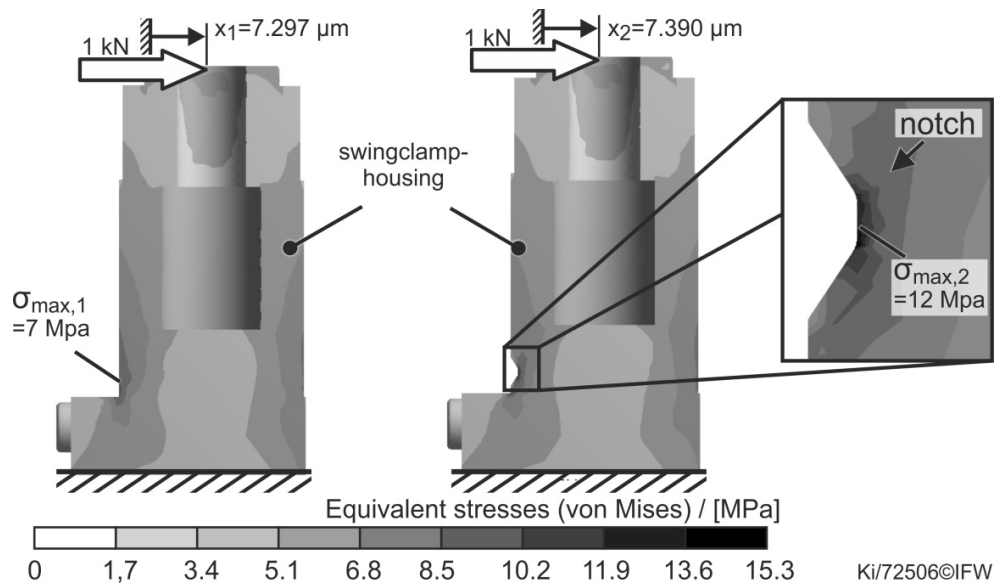

Fig. 6. Increasing the strain gauge sensitivity at the swing clamp.

4. Conclusion

The present paper shows latest results from the development of a sensing clamping fixture for the use in industrial environment. The research is conducted within a joint research project with industrial partners.

At first, a general overview of the system structure and the description of the targeted clamping fixture design are given. To provide the fixture with sensing capabilities the concept for the sensor integration is explained. It comprises the application of strain gauges at the hydraulic clamping elements. In order to measure different influences on the strain distribution several positions for the sensor placing are discussed.

The usability of integrated strain gauges for the indirect measurement of hydraulic pressure is verified on the basis of an experimental set-up with a hydraulic swing clamp. The measured signals demonstrate the dependency of the strain gauge locations to a further desired quantity, the end position of the clamping piston, and thereby the capability for its estimation vice versa. To improve this estimation a method to increase sensor sensitivity by applying notches to the clamping element is presented. Based on finite element simulations the improvement of sensor sensitivity by 71 % to the detriment of the compliance by 1.3 % is achievable. In further experimental investigations this method will be used for sensor integration to enable force and position monitoring.

Acknowledgements

The authors thank the German Research Foundation (DFG) for funding this research within the collaborative research center 653.

References

- [1] Wang H, Rong Y, Li H, Shaun P. Computer aided fixture design: Recent research and trends. *Computer-Aided Design* 2010;42(12):1085-1094.
- [2] Nelaturi S, Rangarajan A, Fritz C, Kurtoglu T. Automated fixture configuration for rapid manufacturing planning. *Computer-Aided Design* 2014;46:160–169.
- [3] Kang X, Peng Q. Recent Research on Computer-Aided Fixture Planning. *MENG (Recent Patents on Mechanical Engineering)* 2009;2:8-18.
- [4] Boyle I, Rong Y, Brown DC. A review and analysis of current computer-aided fixture design approaches. *Robotics and Computer-Integrated Manufacturing* 2011;27(1):1-12.
- [5] Möhring HC, Litwinski KM, Gümmer O. Process monitoring with sensory machine tool components. *CIRP Annals - Manufacturing Technology* 2010;59 (1):383–386.
- [6] Denkena B, Möhring HC, Litwinski KM, Brouwer D. Sensory Z-Slide for Machine Tools. *Proceedings of the SysInt2012 Conference 2012, Hanover (Germany)*.
- [7] Teti R, Jemielniak K, O'Donnell G, Dornfeld D. Advanced monitoring of machining operations. *CIRP Annals - Manufacturing Technology* 2010;59 (2):717-739.
- [8] Neugebauer R, Denkena B, Wegener K. Mechatronic Systems for Machine Tools. *CIRP Annals - Manufacturing Technology* 2007;56 (2): 657-686.
- [9] Nee, AYC, Kumar A, Senthil, Tao ZJ. An intelligent fixture with a dynamic clamping scheme. *Proceedings of the Institution of Mechanical Engineers, Part B: Journal of Engineering Manufacture* 2000;214(3): 183-196.
- [10] Stavropoulos P, Chantzis D, Doukas C, Papacharalampopoulos A., Chryssolouris G. Monitoring and Control of Manufacturing Processes: A Review. *Procedia CIRP* 2013;8:421–425.
- [11] Litwinski KM. Sensorisches Spannsystem zur Überwachung von Zerspanprozessen in der Einzelteilerfertigung. PhD thesis, Leibniz University Hanover. Hanover: 2011.
- [12] Denkena B, Litwinski KM, Brouwer D, Boujnah H. Design and analysis of a prototypical sensory Z-slide for machine tools. *Prod. Eng. Res. Devel.* 2013;7(1):9-14.
- [13] Neuber H. *Kerbspannungslehre*. 4th ed. Heidelberg: Springer; 2001.